

This Owner's Manual is provided and hosted by [Appliance Factory Parts](#).



VIKING DESO127 Owner's Manual

[Shop genuine replacement parts for VIKING DESO127](#)



[Find Your VIKING Oven Parts - Select From 98 Models](#)

----- Manual continues below -----

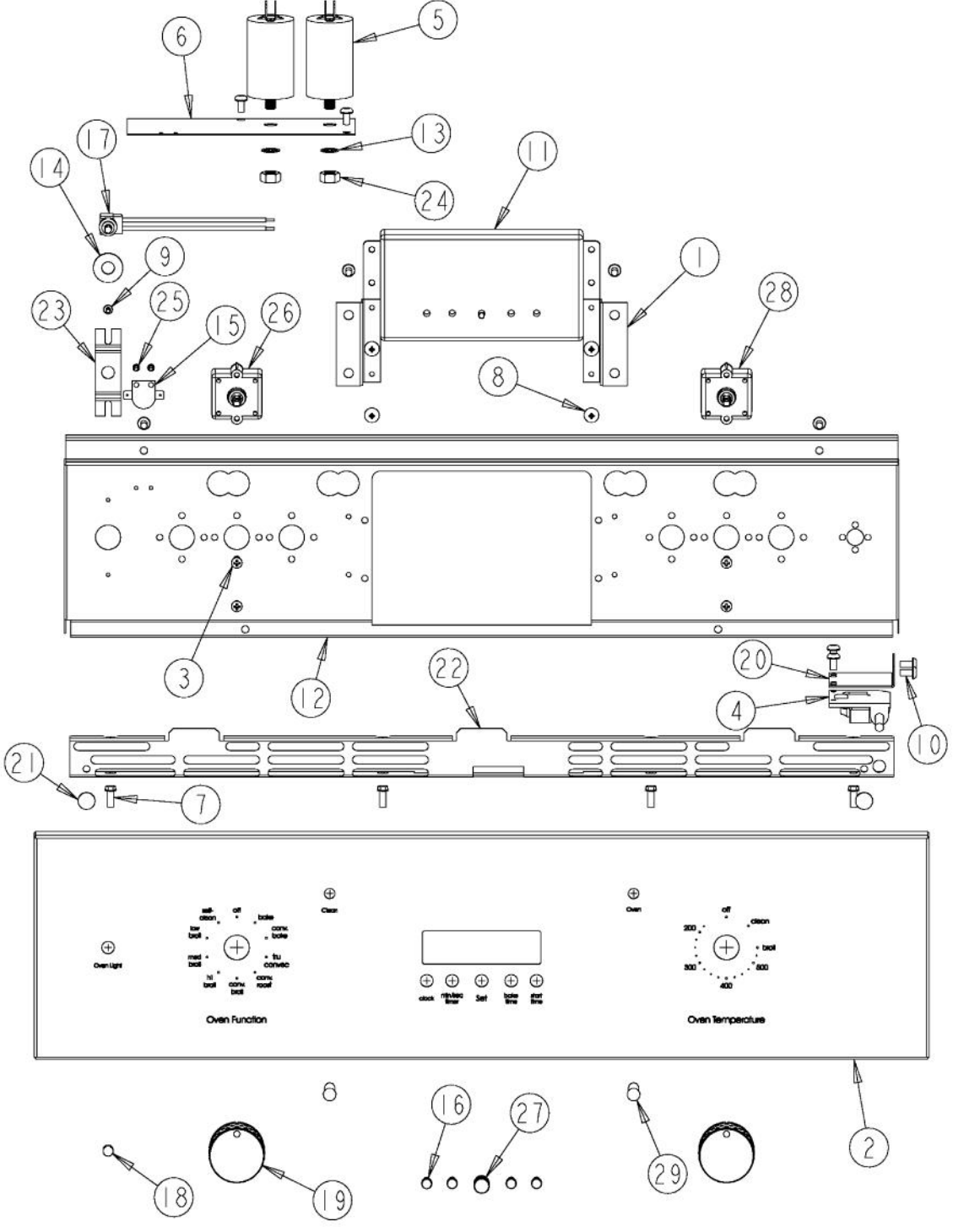

Ref #	Part Number	Qty.	Description
1	A20012638		CLOCK BRACKET
2	B92012628		27 PREM SINGLE CONTROL PNL
2	C92012628BK		27 PREM SINGLE CONTROL PNL XBKX
2	C92012628BT		CONTROL PANEL - BT
2	C92012628GG		CONTROL PANEL - GG
2	C92012628SG		CONTROL PANEL - SG
2	C92012628WH		CONTROL PANEL - WH
3	PD020261		NO.8-32X1/2 PH PANHEAD MACH. SCREW
4	PE050208		DOOR SWITCH
5	PE050247		EBM FAN MOTOR CAPACITOR
6	A10014028		2 CAPACITOR BRACKET
7	PD020060		10 X 1/2 (5/16)HEX WSHR HD.(T)A
8	PD010003		10-24 X 1/2 PH.TR.HD.SERD.M.S.
9	PD020006		NO.6-32 X 1/4 PH.PAN HD. T(F)
10	PD020004		10X3/8PH.HD.TYPE 25 REPL PD040125
11	PE050214		CLOCK (DIGITAL 230V 50/60HZ)
12	A20012636		27 CONTROL MTG. PANEL
13	PD040164		5/16 INTERNAL TOOTH LOCK WASHER TYPE A
14	PD040160		3/8 STEEL WASHER
15	G50015486		DESIGNER LIMIT SWITCH KIT (BEFORE 07-24-06)
NI	PJ030043		BI-METAL THERMOSTAT (N.C.) 180 DEGREES (AFTER 07-24-06)
16	PB010315		DES. CLOCK BUTTON
17	PE050076		DESIGNER OVEN LIGHT SWITCH
18	PA010093		DESIGNER OVEN LT SWITCH KNOB
18	PA010093PVD		DESIGNER OVEN LT SWITCH KNOB-BRASS
19	PA010194		DES. SELECTOR/THERMOSTAT KNOB
19	PA010194PVD		DES. SELECTOR/THERMOSTAT KNOB-BRASS
19	PA010195		DES. SELECTOR/THERMOSTAT KNOB - GREY
19	PA010195PVD		SELECTOR / THERMOSTAT KNOB - WH / BR
20	A20012649		DOOR SWITCH BRACKET
21	PD040004		GROMMET BUMPER
22	C90014073BK		27 INLET GRILL
23	A10014045		LIGHT SWITCH BRACKET
24	PD030172		M8 X 1.25MM NUT
25	PD020013		TYPE AB NO.6 X 3/8 PH PAN HD. SMS
26	PJ030033		SELECTOR (10 POS)
27	PB010314		TEST DESIGNER BIT GENERATOR KNOB
27	PB010314PVD		TEST DESIGNER BIT GENERATOR KNOB-BRASS
28	PJ030035		THERMOSTAT
29	PE050078		VECU POWER LIGHT

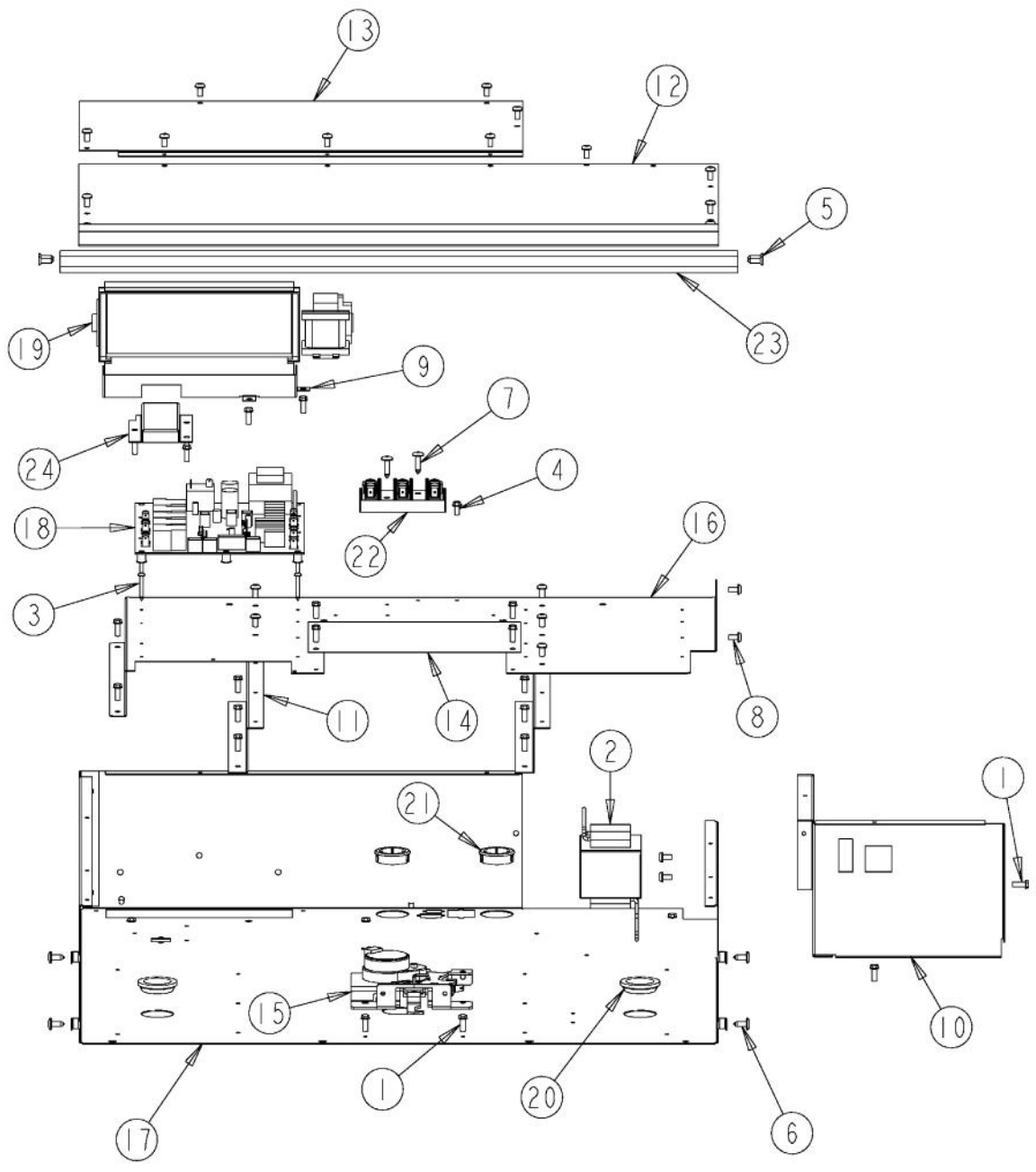

Ref #	Part Number	Qty.	Description
1	PD020060		10 X 1/2 (5/16)HEX WSHER HD.(T)A
2	PE070634		HALOGEN LIGHT TRANSFORMER
3	PD020185		NO.6 X 1 PAN HEAD SCREW
4	PD020010		10 X 3/8 GREEN GROUNDING SCREW
5	PD020231		NO.8 X 1/2 PH FLAT HEAD TEK SCREW (BLACK OXIDE)
6	PD020002		10 X 1/2 PH.TR.HD.SMS.
7	PD020014		10X3/4 PH TR HD SMS
8	PD020004		10X3/8PH.HD.TYPE 25 REPL PD040125
9	A20014035		27 BLOWER BRACKET
10	A20010934		BRACKET, MODULE PAN
11	A20010910		BRACKET, SUPPORT, ELECTRONICS HAT
12	A20014046		27 FRONT COVER
13	A20014047		27 REAR COVER
14	A10010911		COVER, LATCH
15	PE050210		DOOR LATCH
16	A20010935		ELECTRONICS HAT
17	A20010933		MODULE PAN 27
18	PE070631		CONTROL BOARD
19	PE050228		PREMIUM BLOWER
20	PB070079		SILICONE EXTRUSION (DGSU)
21	PD040152		SNAP BUSHING
22	PE070147		TERMINAL BLOCK
23	PE040279		27 DES. TOP TRIM
24	A20014033		UPPER VENT COVER

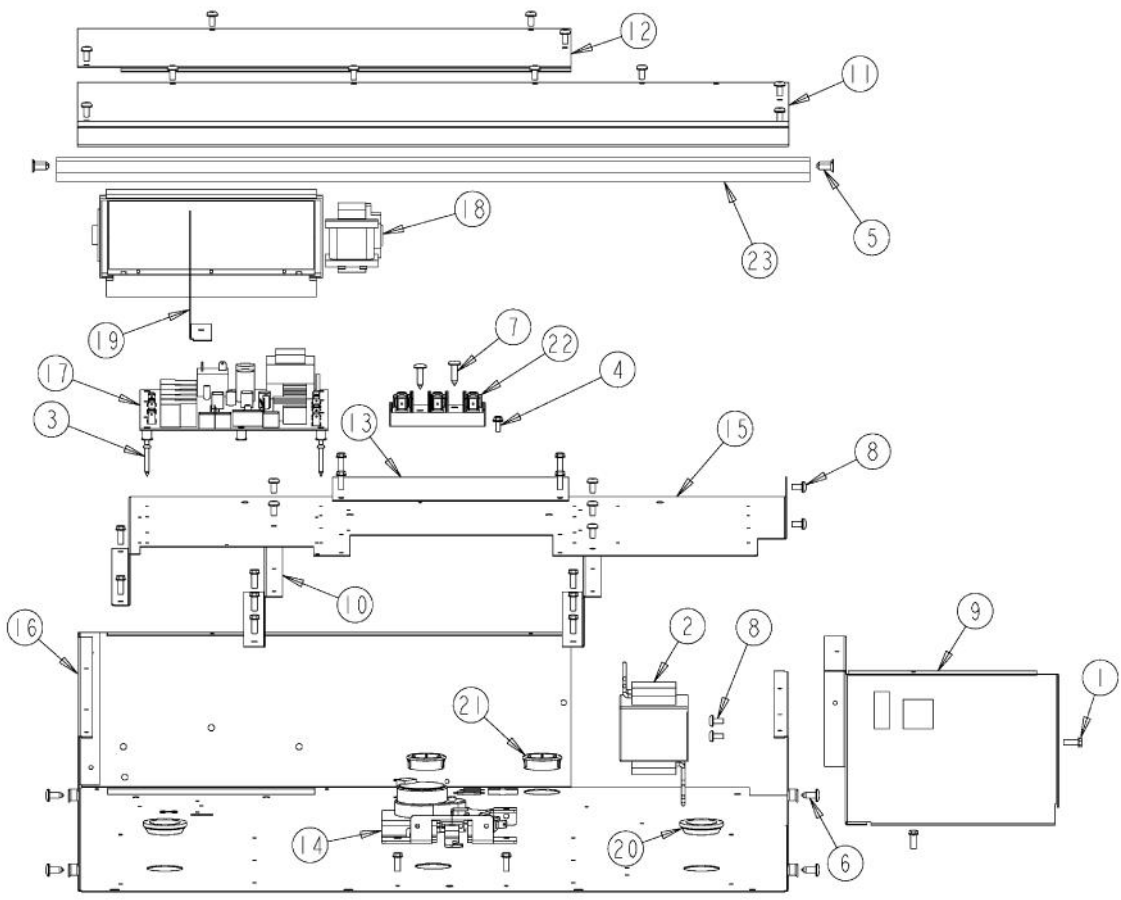

Ref #	Part Number	Qty.	Description
1	PD020060		10 X 1/2 (5/16)HEX WSHR HD.(T)A
2	PE070634		HALOGEN LIGHT TRANSFORMER (USED ONLY ON UNITS BEFORE SERIAL NO. C-0396)
3	PD020185		NO.6 X 1 PAN HEAD SCREW
4	PD020010		10 X 3/8 GREEN GROUNDING SCREW
5	PD020231		NO.8 X 1/2 PH FLAT HEAD TEK SCREW (BLACK OXIDE)
6	PD020002		10 X 1/2 PH.TR.HD.SMS.
7	PD020014		10X3/4 PH TR HD SMS
8	PD020004		10X3/8PH.HD.TYPE 25 REPL PD040125
9	A20010934		BRACKET, MODULE PAN
10	A20010910		BRACKET, SUPPORT, ELECTRONICS HAT
11	A20014046		27 FRONT COVER
12	A20014047		27 REAR COVER
13	A10010911		COVER, LATCH
14	PE050210		DOOR LATCH
15	A20010935		ELECTRONICS HAT
16	A20010933		MODULE PAN 27
17	PE070631		CONTROL BOARD
18	PE050228		PREMIUM BLOWER
19	A2009667		REAR AIR DIVIDER
20	PB070079		SILICONE EXTRUSION (DGSU)
21	PD040152		SNAP BUSHING
22	PE070147		TERMINAL BLOCK
23	PE040279		27 DES. TOP TRIM

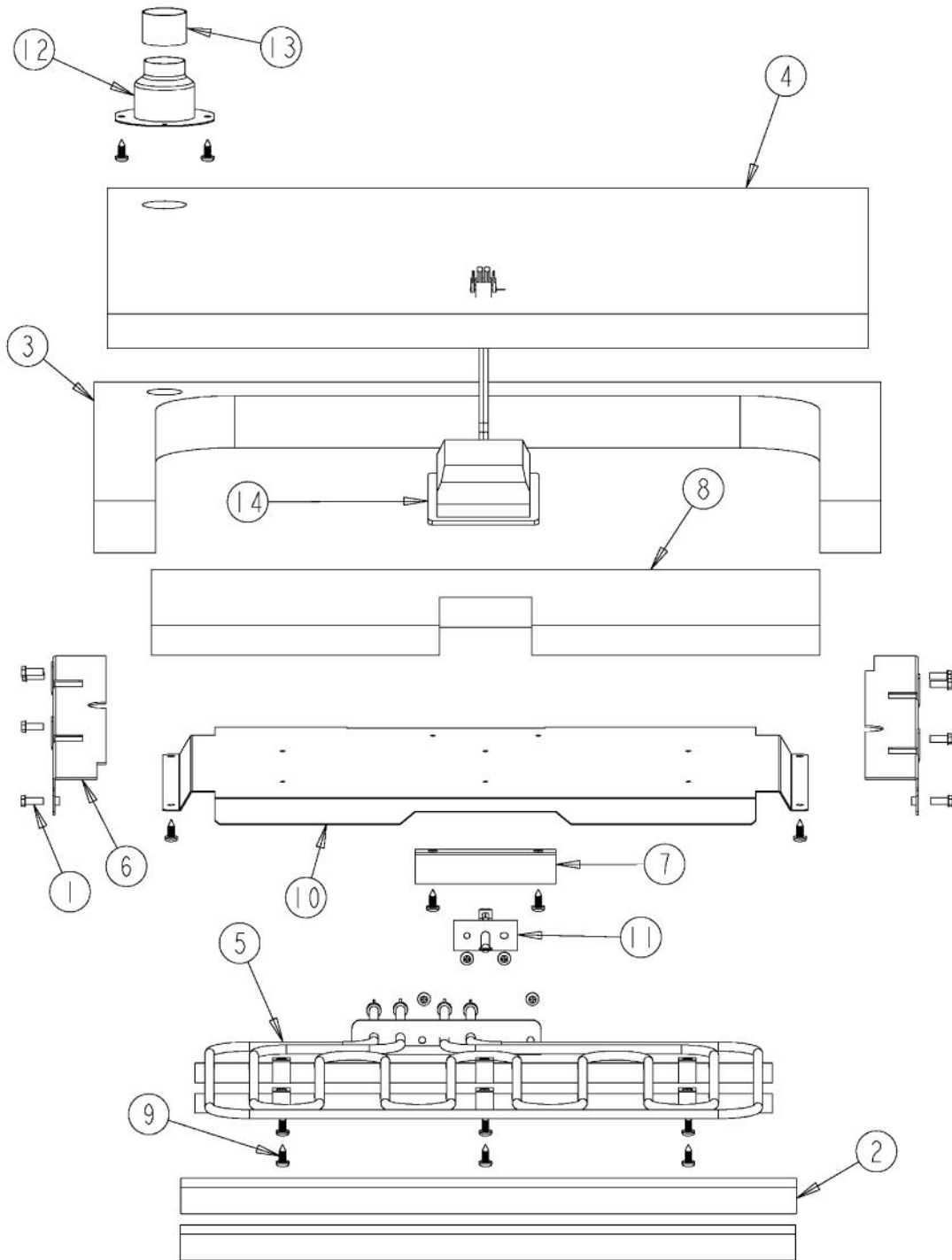

Ref #	Part Number	Qty.	Description
1	PD020060		10 X 1/2 (5/16)HEX WSHR HD.(T)A
2	PB070273		27 WINDOW PACK INSULATION
3	PB070306		27 TOP BROIL INSULATION
4	PB070307		27 TOP INSULATION
5	PJ010049		BROIL ELEMENT
6	A2009641		BRKT, TOP WRAPPER
7	A20014044		BROIL ELEMENT SHIELD
8	PB070337		LINER FRONT INSULATION
9	PD020055		NO.10 X 1/2 PAN PHIL. TEK. SS
10	A20014021		REFLECTOR, BROIL
11	PE050206		RTD THERMOSTAT PROBE
12	PM010014		SMOKE ELIMINATOR (VDSC)
13	PB020275		VENT TUBE
14	PE050205		TOP HALOGEN LIGHT (BEFORE C-0396)
NI	PE050239		HALOGEN LAMP (AFTER C-0396)

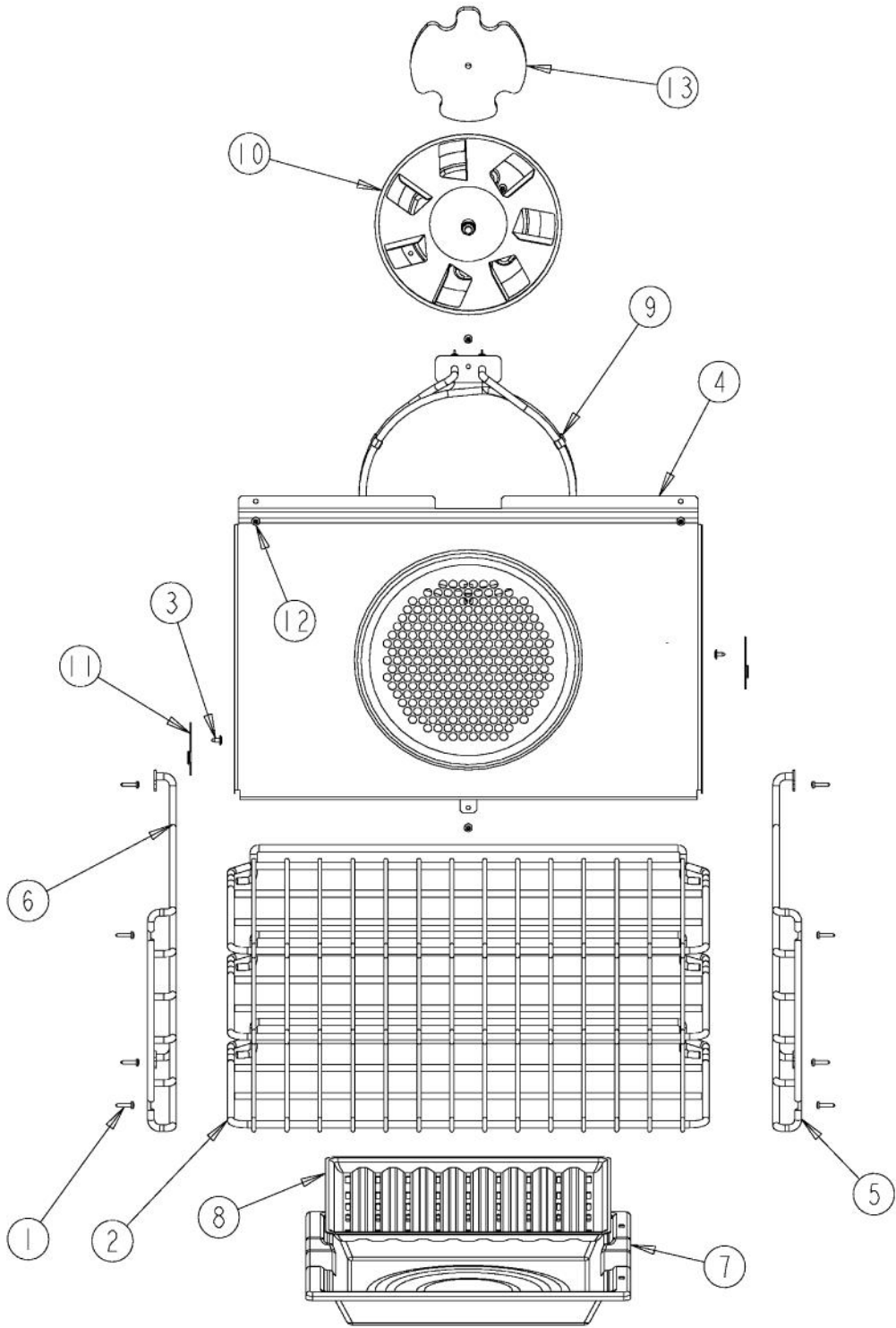

Ref #	Part Number	Qty.	Description
1	PD020232		NO.8 X 3/4 PH PAN HEAD TEK SCREW (BLACK OXIDE)
2	PB060105		27 OVEN RACK
3	PD020063		SCREW-NO.8(A) X 3/8PH WFR HD/BK OXID
4	G91013597		27 BAFFLE ASSEMBLY
5	PB060103		RACK SUPPORT RH
6	PB060104		RACK SUPPORT LH
7	E9107933		BROILER PAN
8	E9107934		BROILER PAN INSERT
9	PJ010047		CONVECTION ELEMENT
10	G32014020		CONVECTION FAN ASSY
11	E91012614		LIGHT HOLE COVER
12	PD020055		NO.10 X 1/2 PAN PHIL. TEK. SS
13	PB070312		CONVECTION MOTOR MTG. PLATE INSULATION
NI	001097-000		FAN MOTOR JUMPER

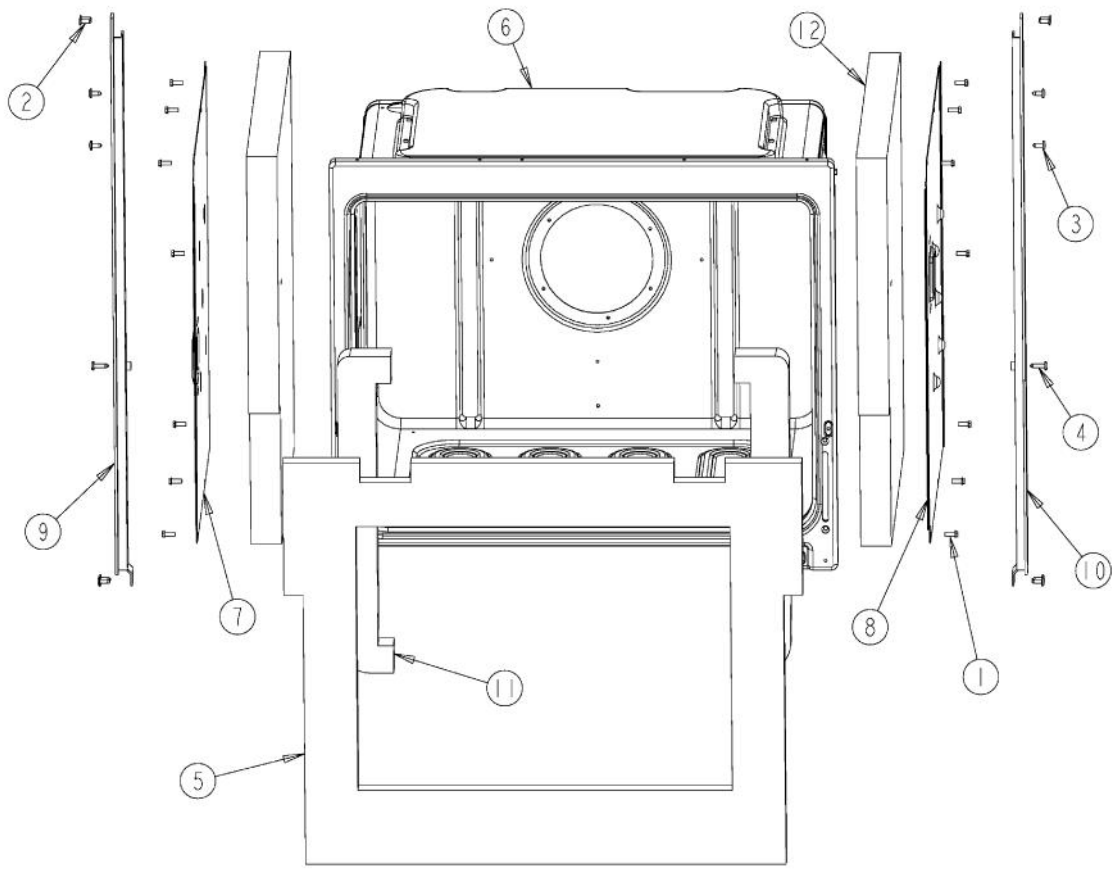

Ref #	Part Number	Qty.	Description
1	PD020060		10 X 1/2 (5/16)HEX WSHR HD.(T)A
2	PD020002		10 X 1/2 PH.TR.HD.SMS.
3	PD020014		10X3/4 PH TR HD SMS
4	PB070276		27 DOOR INSULATION
5	G91014042		27 PREMIERE CAVITY ASSY
6	A20012650		BRKT, TOP WRAPPER LEFT
7	A2009622		BRKT, TOP WRAPPER, RIGHT
8	PE040282		DES. SINGLE SIDE TRIM LH
9	PE040281		DES. SINGLE SIDE TRIM RH
10	E91014053		PORCELAIN 25/64 HOLE PLUG
11	PB070271		DOOR PLUG INSULATION
12	PB070302		SIDE INSULATION

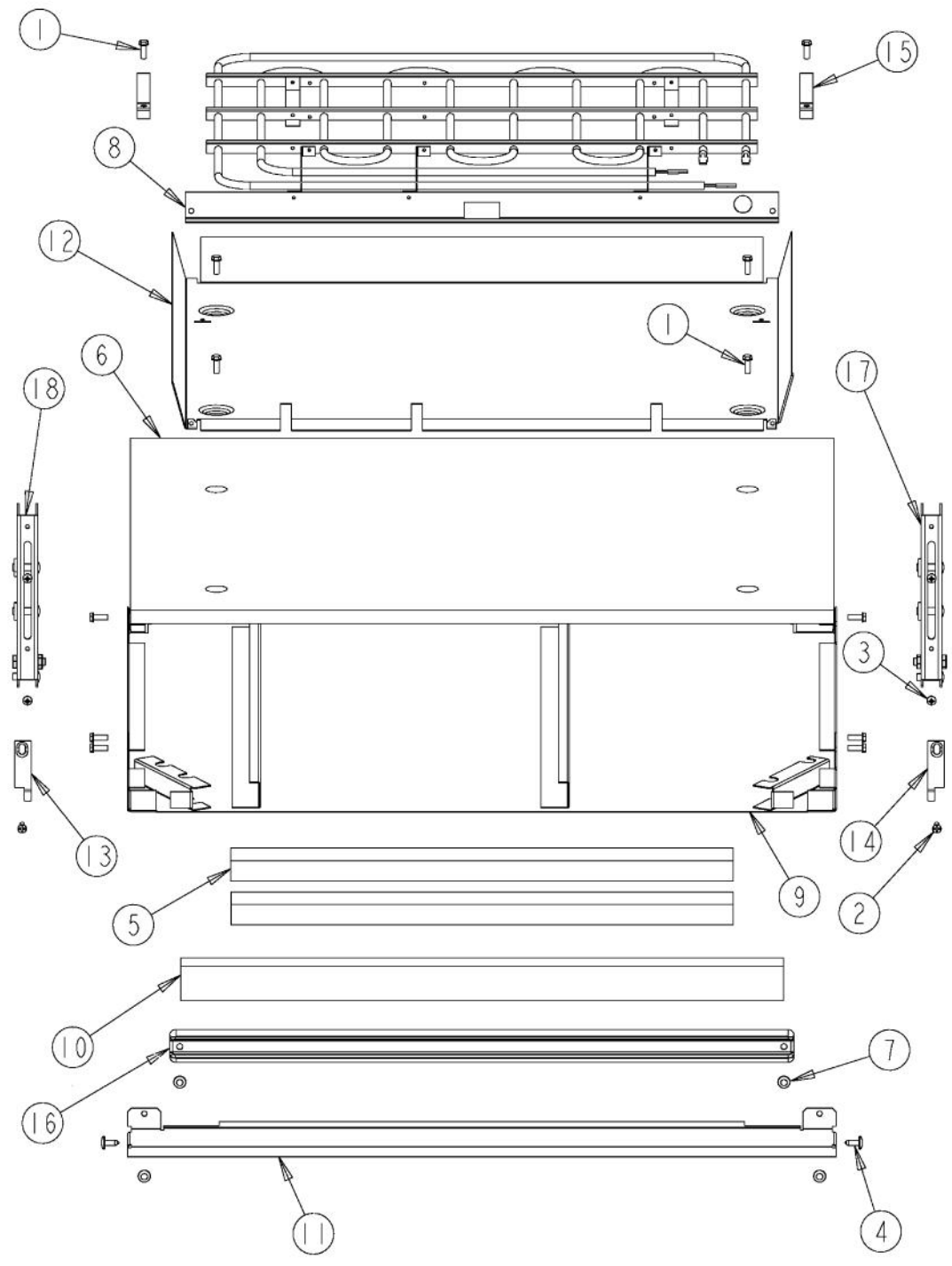

Ref #	Part Number	Qty.	Description
1	PD020060		10 X 1/2 (5/16)HEX WSHR HD.(T)A
2	PD020061		NO.8 X 3/4 FLAT HD TEK. SS.
3	PD020062		NO.8-32 X 3/8 PHMS TYPE 1
4	PD020002		10 X 1/2 PH.TR.HD.SMS.
5	PB070273		27 WINDOW PACK INSULATION
6	PB070300		27 BOTTOM INSULATION
7	PD020063		SCREW-NO.8(A) X 3/8PH WFR HD/BK OXID
8	PJ010048		BAKE ELEMENT
9	G30010922		BASE MODULE ASSY 27
10	PB070309		BAKE ELEMENT INSULATION
11	C90012822BK		BOTTOM AIR DEFLECTOR 27
12	A20010932		ELEMENT, MTG TRAY
13	B21010916		HINGE CLIP ? LH
14	B21010915		HINGE CLIP ? RH
15	A2009696		HOLDER, BAKE ELEMENT
16	E9109655		BAKE TRAY COVER
17	PC020221		HINGE POCKET RECEIVER MANSFIELD RH
18	PC020247		HINGE POCKET RECEIVER MANSFIELD LH

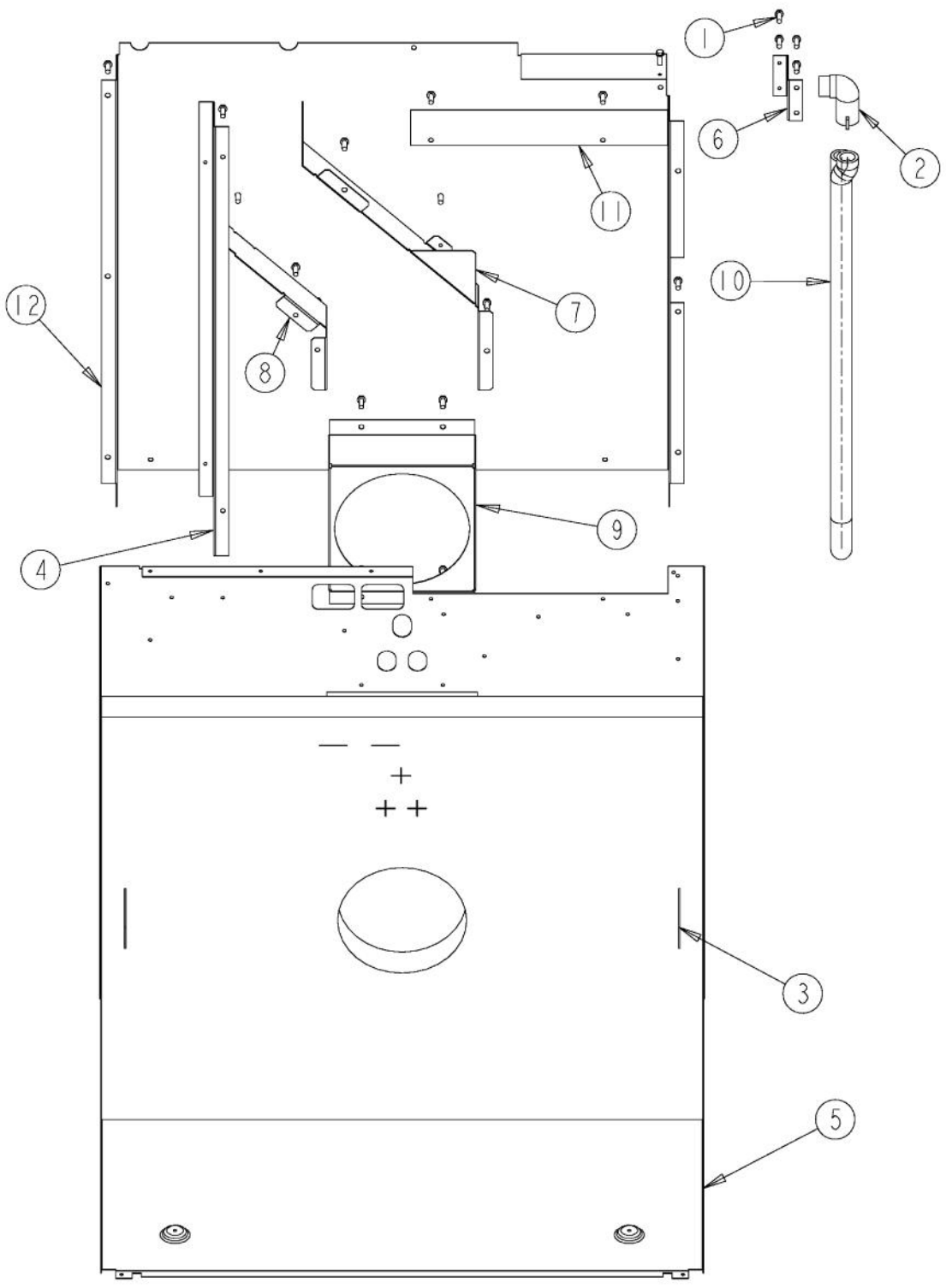

Ref #	Part Number	Qty.	Description
1	PD020060		10 X 1/2 (5/16)HEX WSHER HD.(T)A
2	PB040070		CONDUIT FITTING (90 DEG)
3	PB070301		27 BACK INSULATION
4	A2009666		AIR CHANNEL
5	A20010931		BASE, BACK WRAPPER, 27
6	A2009671		BRACKET, POWER CABLE
7	A21010918		BRACKET, AIR, CONVECTION MOTOR
8	A21010919		BRACKET, AIR, CONVECTION MOTOR
9	A2009697		BRACKET, CONVECTION INSULATION
10	PB020071		CONDUIT - FLEXIBLE (48)
11	A10010907		COVER, BLOWER
12	A20010937		PANEL, REAR 27

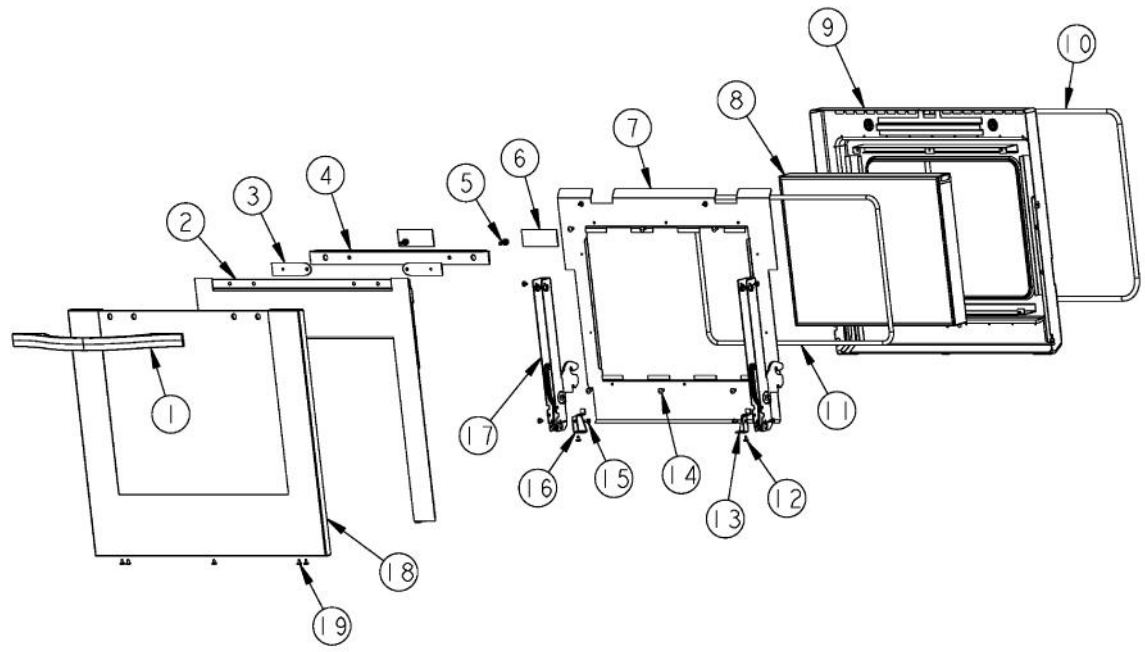

Ref #	Part Number	Qty.	Description
1	PE030167		30 DOOR HANDLE
1	PE030167PVD		30 DOOR HANDLE PVD
2	001498-000		DESIGNER 27`` INSULATION RETAINER KIT
3	PC050002		DESIGNER DOOR HANDLE SPACER
4	PE040285		DESIGNER DOOR TRIM
5	PD020186		1/4-20 X 3/4 HEX WASHER HEAD MS
6	PB070336		DOOR BRACKET INSULATION
7	A20010949		PANEL, INSULATION, INNNER DOOR
8	PE060093		27 WINDOW PACK
9	G91010942		DOOR LINER ASSEMBLY
10	PB070245		27 DOOR GASKET
11	000594-000		BLACK FIBERGLASS ROPE 3/8
12	PD020063		SCREW-NO.8(A) X 3/8PH WFR HD/BK OXID
13	A20012640		HINGE SUPPORT RH
14	PD020002		10 X 1/2 PH.TR.HD.SMS.
15	PD020004		10X3/8PH.HD.TYPE 25 REPL PD040125
16	A20012641		HINGE SUPPORT LH
17	023796-000	2	HINGE, MANSFIELD, PURPLE
18	001453-002		27 IN DES. DOOR SKIN KIT W/LOGO - BK
18	001453-003		27 IN DES. DOOR SKIN KIT W/LOGO - BT
18	001453-005		27 IN DES. DOOR SKIN KIT W/LOGO - GG
18	001453-004		27 IN DES. DOOR SKIN KIT W/LOGO - SG
18	001453-000		27 IN DES. DOOR SKIN KIT W/LOGO - SS
18	001453-006		27 IN DES. DOOR SKIN KIT W/LOGO - WH
19	PD020032		SRW-8(A)X3/8PH.WFR HD 7/16DIAXNICL
NI	G32012811BK		27 DOOR ASSY W/LOGO XBKX
NI	G32012811BKBR		27 DOOR ASSY W/LOGO XBKBRX
NI	G32012811BT		27 DOOR ASSY W/LOGO XBTX
NI	G32012811BTBR		27 DOOR ASSY W/LOGO XBTBRX
NI	G32012811GG		27 DOOR ASSY W/LOGO XGGX
NI	G32012811GGBR		27 DOOR ASSY W/LOGO XGGBRX
NI	G32012811SG		27 DOOR ASSY W/LOGO XSGX
NI	G32012811SGBR		27 DOOR ASSY W/LOGO XSGBRX
NI	G32012811SS		27 DOOR ASSY W/LOGO
NI	G32012811SSBR		27 DOOR ASSY W/LOGO XSSBRX
NI	G32012811WH		27 DOOR ASSY W/LOGO XWHX
NI	G32012811WHBR		27 DOOR ASSY W/LOGO XWHBRX
NI	017736-000		WINDOW PACK INSULATION KIT

1

3 POSITION CONNECTOR

1 2 3
1 2 3

WIRE INSERTION VIEW



TERMINALS					
CODE	TYPE	SIZE	INSULATED	MATERIAL	COLOR
A	STRAIGHT	0.25	YES	STEEL	RED
B	STRAIGHT	0.25	YES	STEEL	BLUE

WIRE		
RUN	COLOR	GAGE
1	ORANGE	18
2	BLUE	18
3	ORANGE	18

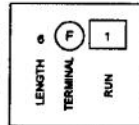

2

9 POSITION MATE & LOCK CONNECTOR

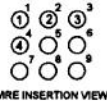

WIRE INSERTION VIEW



5"

5"

1 2 3 4
1 2 3 4

WIRE INSERTION VIEW



4 POSITION MATE & LOCK CONNECTOR



WIRE INSERTION VIEW

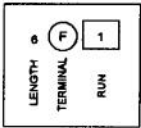

TERMINALS					
CODE	TYPE	SIZE	INSULATED	MATERIAL	
A	STRAIGHT	0.25	YES	STEEL	
B	STRAIGHT	0.25	KYNAR	STEEL	
C	STRAIGHT	0.187	YES	STEEL	
D	FLAG	0.25	YES	STEEL	
F	FLAG	0.187	YES	STEEL	
G	STRAIGHT	0.25	NO	STEEL	
H	RING	0.25	NO	STEEL	
I	PIGGYBACK	0.25	YES	STEEL	

WIRE		
RUN	COLOR	GAGE
1	BLACK	18
2	WHITE	18
3	RED	18
4	GREEN	18
5	BLACK	18
6	YELLOW	18

* = WIRE TIE LOCATION

3

3 POSITION CONNECTOR

1 2 3
1 2 3

WIRE INSERTION VIEW



29"

WELD 1

29"

(W)



TERMINALS					
CODE	TYPE	SIZE	INSULATED	MATERIAL	
A	STRAIGHT	0.25	YES	STEEL	
B	STRAIGHT	0.25	KYNAR	STEEL	
C	STRAIGHT	0.187	YES	STEEL	
D	FLAG	0.25	YES	STEEL	
F	FLAG	0.187	YES	STEEL	
G	STRAIGHT	0.25	NO	STEEL	
H	RING	0.25	NO	STEEL	
W	WELD / SPLICE				

WIRE		
RUN	COLOR	GAGE
1	WHITE	14
2	WHITE	18
3	WHITE	18
4	WHITE	18
5	WHITE	18

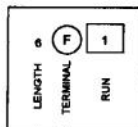

Ref #	Part Number	Qty.	Description
1	PE070743		SINGLE CLOCK HARNESS
2	PE070754		TEST HARNESS SINGLE
3	PE070739		BAKE ELEMENT HARNESS
NI	G4005496		SUPPLY WIRE - 100 BK 10GA SO/DO
NI	G4005497		SUPPLY WIRE - 100 GREEN 10GA SO/DO
NI	G4005499		SUPPLY WIRE - 100 RED 10GA SO/DO
NI	G4005494		SUPPLY WIRE - 75 WH 12 GA SO/DO

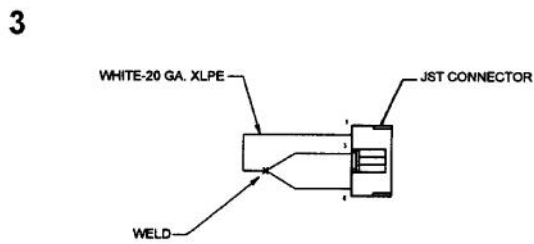
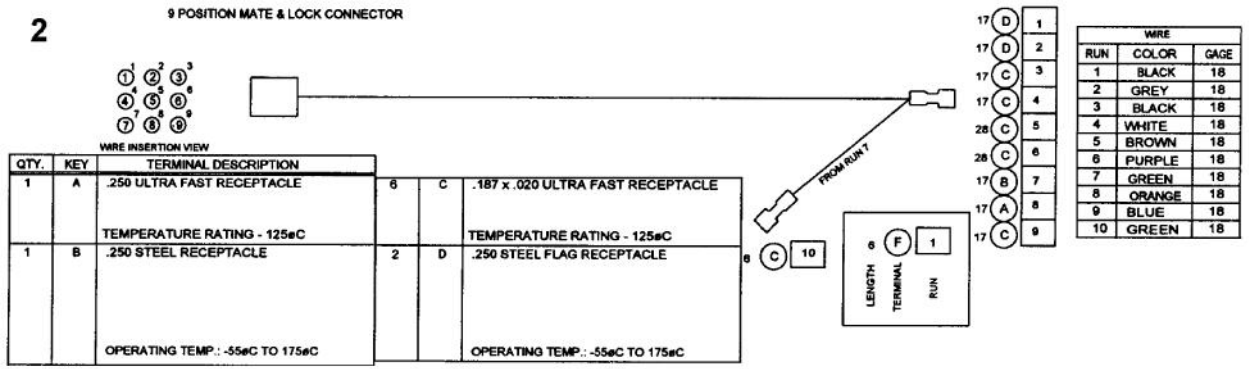
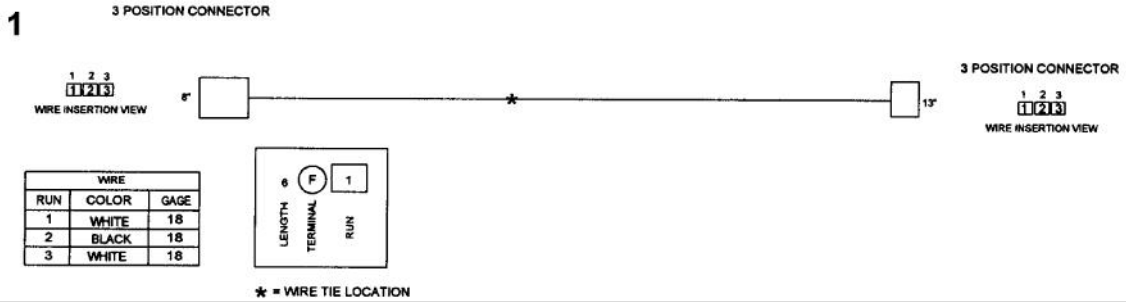

Ref #	Part Number	Qty.	Description
1	PE070738		T/STAT-SEL HARNESS
2	PE070733		UPPER LATCH HARNESS
3	PE070734		SINGLE OVEN HEADER

1

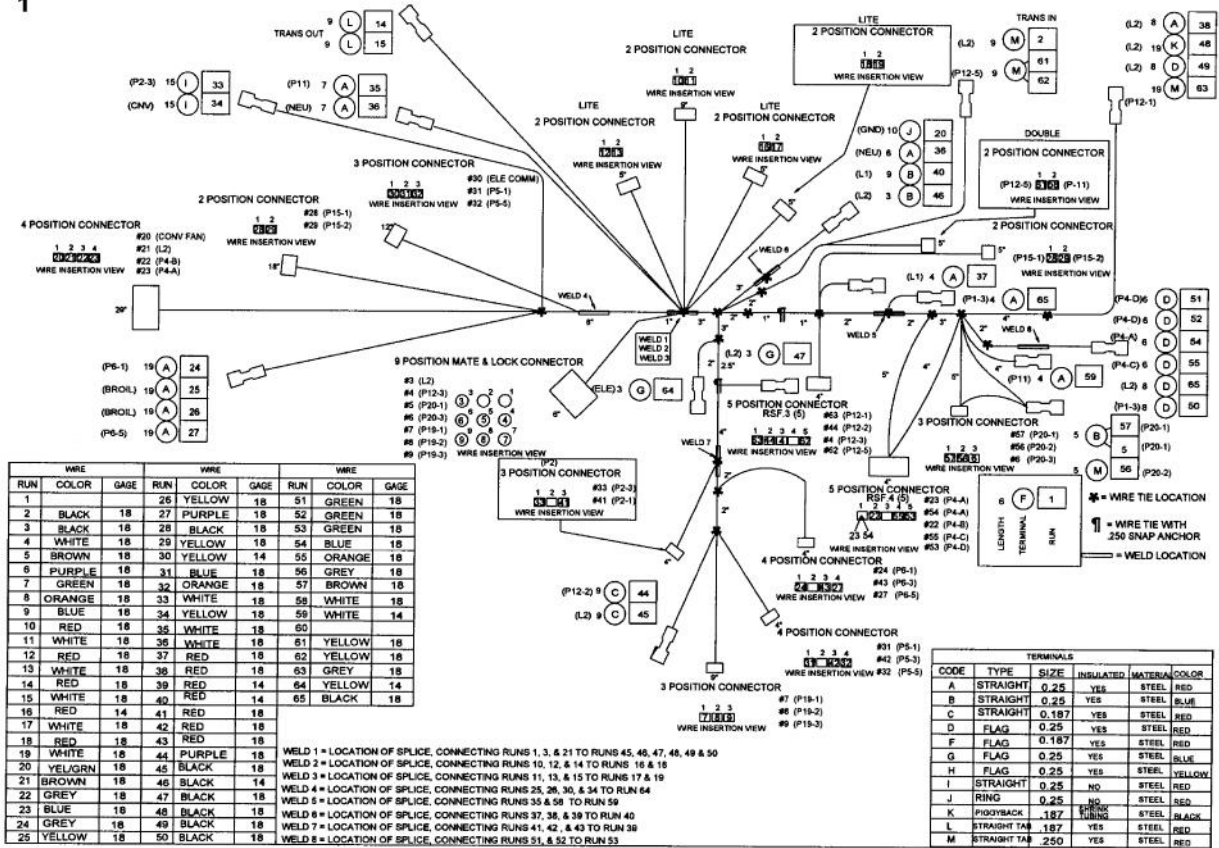

WIRE	WIRE	WIRE	WIRE	WIRE	WIRE	WIRE	WIRE	
RUN	COLOR	GAGE	RUN	COLOR	GAGE	RUN	COLOR	GAGE
1			25	YELLOW	18	51	GREEN	18
2	BLACK	18	27	PURPLE	18	52	GREEN	18
3	BLACK	18	28	BLACK	18	53	GREEN	18
4	WHITE	18	29	YELLOW	18	54	BLUE	18
5	BROWN	18	30	YELLOW	14	55	ORANGE	18
6	PURPLE	18	31	BLUE	18	56	GREY	18
7	GREEN	18	32	ORANGE	18	57	BROWN	18
8	ORANGE	18	33	WHITE	18	58	WHITE	18
9	BLUE	18	34	YELLOW	18	59	WHITE	14
10	RED	18	35	WHITE	18	60		
11	WHITE	18	36	WHITE	18	61	YELLOW	18
12	RED	18	37	RED	18	62	YELLOW	18
13	WHITE	18	38	RED	18	63	GREY	18
14	RED	18	39	RED	14	64	YELLOW	14
15	WHITE	18	40	RED	14	65	BLACK	18
16	RED	14	41	RED	18			
17	WHITE	18	42	RED	18			
18	RED	18	43	RED	18			
19	WHITE	18	44	PURPLE	18			
20	YELLOW	18	45	BLACK	18			
21	BROWN	18	46	BLACK	14			
22	GREY	18	47	BLACK	18			
23	BLUE	18	48	BLACK	18			
24	GREY	18	49	BLACK	18			
25	YELLOW	18	50	BLACK	18			

WELD 1 = LOCATION OF SPLICE, CONNECTING RUNS 1, 3, & 21 TO RUNS 45, 46, 47, 48, 49 & 50
 WELD 2 = LOCATION OF SPLICE, CONNECTING RUNS 10, 13, & 14 TO RUNS 16 & 18
 WELD 3 = LOCATION OF SPLICE, CONNECTING RUNS 11, 13, & 15 TO RUNS 17 & 19
 WELD 4 = LOCATION OF SPLICE, CONNECTING RUNS 25, 26, 30, & 34 TO RUN 64
 WELD 5 = LOCATION OF SPLICE, CONNECTING RUNS 35 & 58 TO RUN 59
 WELD 6 = LOCATION OF SPLICE, CONNECTING RUNS 37, 38, & 39 TO RUN 40
 WELD 7 = LOCATION OF SPLICE, CONNECTING RUNS 41, 42, & 43 TO RUN 38
 WELD 8 = LOCATION OF SPLICE, CONNECTING RUNS 51, & 52 TO RUN 53

CODE	TYPE	SIZE	INSULATED	MATERIAL	COLOR
A	STRAIGHT	0.25	YES	STEEL	RED
B	STRAIGHT	0.25	YES	STEEL	BLUE
C	STRAIGHT	0.187	YES	STEEL	RED
D	FLAG	0.25	YES	STEEL	RED
F	FLAG	0.187	YES	STEEL	RED
G	FLAG	0.25	YES	STEEL	BLUE
H	FLAG	0.25	YES	STEEL	YELLOW
I	STRAIGHT	0.25	NO	STEEL	RED
J	RING	0.25	NO	STEEL	RED
K	PIGGYBACK	187	NO	STEEL	BLACK
L	STRAIGHT TAB	187	YES	STEEL	RED
M	STRAIGHT TAB	250	YES	STEEL	RED

Ref #	Part Number	Qty.	Description
1	PE070742		UPPER CONTROL HARNESS