

This Owner's Manual is provided and hosted by [Appliance Factory Parts](#).



# Smoke Hollow D4015B Owner's Manual

[Shop genuine replacement parts for Smoke Hollow  
D4015B](#)



[Find Your Smoke Hollow Grill Parts - Select From 115 Models](#)

----- Manual continues below -----



# Digital Electric Smoker

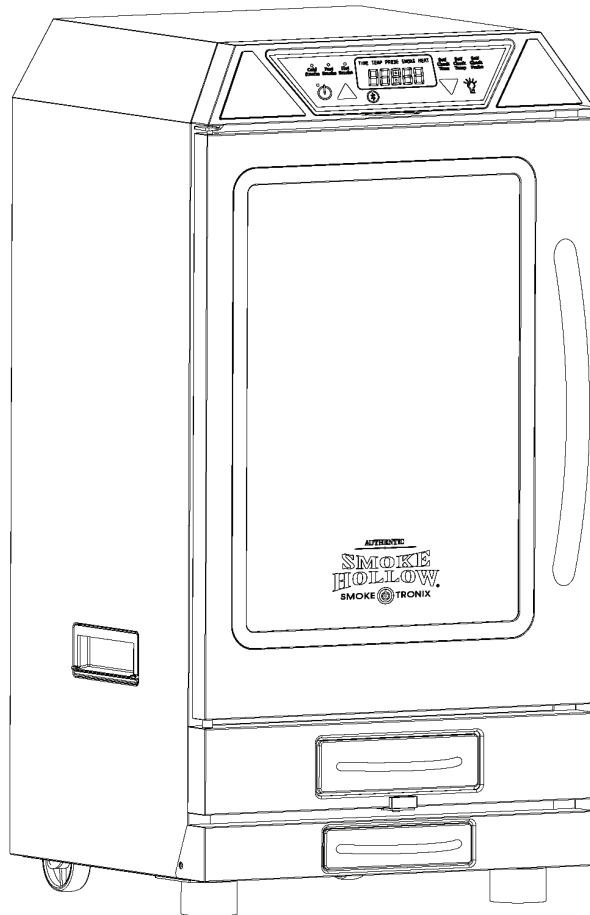

For Models  
**D4015SS / D4015B**  
and **D4015R**



**THIS IS YOUR ASSEMBLY, CARE & USE MANUAL  
WITH IMPORTANT WARNING & SAFETY INFORMATION.  
PLEASE SAVE THESE INSTRUCTIONS.**

Approximate assembly time: 20 minutes  
Tools needed for assembly: Phillips head screwdriver

---

**FOR OUTDOOR USE ONLY**

# **WARNING**

THIS MANUAL CONTAINS IMPORTANT INFORMATION NECESSARY FOR THE PROPER AND SAFE USE OF THIS UNIT. READ AND FOLLOW ALL WARNINGS AND INSTRUCTIONS BEFORE USING SMOKER AND DURING USE.

**FAILURE TO FOLLOW THESE WARNINGS AND INSTRUCTIONS PROPERLY  
COULD RESULT IN PERSONAL INJURY OR DEATH.**

## **CARBON MONOXIDE HAZARD**

BURNING WOOD CHIPS GIVES OFF CARBON MONOXIDE, WHICH HAS NO ODOR AND CAN CAUSE DEATH. DO NOT BURN WOOD CHIPS INSIDE HOMES, VEHICLES, TENTS, GARAGES OR ANY ENCLOSED AREAS. USE ONLY OUTDOORS WHERE IT IS WELL VENTILATED.

## **GENERAL WARNINGS**

### **READ ALL INSTRUCTIONS**

- Do not leave smoker unattended.
- Do not cover cooking grids with metal foil. This will trap heat and cause severe damage to the electric smoker.
- Drip tray is only for the bottom of electric smoker. Do not put drip tray on cooking rack as this may damage the electric smoker.
- The wood chip tray is HOT when electric smoker is in use. Use caution when handling or adding wood.
- To disconnect, turn control panel "OFF" then remove plug from outlet.
- Unplug from outlet when not in use and before cleaning. Allow unit to cool completely before adding/removing grates, wood chip tray or water pan.
- Dispose of cold ashes by placing them in aluminum foil, soaking with water and discarding in a non-combustible container.
- Do not store the electric smoker with HOT ashes inside unit. Store only when all surfaces are cold.
- Accessory attachments or parts not supplied by Outdoor Leisure Products, Inc. are not recommended and may cause injury.
- Never use the electric smoker for anything other than its intended purpose. This unit is not for commercial use.
- Always use the electric smoker in accordance with all applicable local, state and federal fire codes.
- Longer, detachable power-supply cords or extension cords are available and may be used if care is exercised in their use, based on the following requirements.
- If a longer, detachable power-supply cord or extension cord is used, the marked electrical rating of the cord set or extension cord should be at least as great as the electrical rating of the appliance.
- The extension cord must be a grounding -type 3-wire cord.
- Outdoor extension cords must be used with outdoor use products and are marked with suffix "W" and with the statement "Suitable for Use with Outdoor Appliances."
- CAUTION- To ensure continued protection against risk of electric shock, connect to properly grounded outlets only.
- CAUTION - To reduce the risk of electric shock, keep extension cord connection dry and off the ground.
- Do not clean this product with a water sprayer or the like.
- Do not use wood pellets or wood chunks.
- Store products indoors when not in use - out of reach of children.

**CONTINUED ON  
NEXT PAGE...**

# **GENERAL WARNINGS**

## **When using electrical appliances, basic safety precautions should always be followed including the following:**

- For outdoor use only. Do not operate in an enclosed areas (example, porch or garage).
- Unit **MUST** be on the ground. Do not place unit on tables or counters. Do **NOT** move unit across uneven surfaces.
- Do not lift unit by rear handle.
- Do not plug in the electric smoker until fully assembled and ready for use.
- Use only an approved grounded electrical outlet.
- Do not use during an electrical storm.
- Do not expose the electric smoker to rain or water at anytime.
- **CAUTION-** To ensure continued protection against risk of electric shock, connect to properly grounded outlets only.
- To protect against electrical shock do not immerse cord, plug or control panel in water or other liquid.
- Do not operate any appliance with a damaged cord or plug, or after appliance malfunctions or has been damaged in any manner. Contact OLPI Customer Service for assistance at 1-866-475-5180.
- Keep a fire extinguisher accessible at all times while operating the electric smoker.
- Do not let cord touch hot surfaces.
- Do not place on or near a hot gas or electric burner, or in a heated oven.
- Keep children and pets away from electric smoker at all times. Do not allow children to use electric smoker. Close supervision is necessary should children or pets be in area where the electric smoker is being used.
- Fuel, such as charcoal briquettes or heat pellets, are not to be used in the electric smoker.
- Never use the electric smoker as a heater (**READ CARBON MONOXIDE HAZARD ON PAGE 2**).
- Use the electric smoker only on a level, stable surface to prevent tipping.
- The electric smoker is **HOT** while in use and will remain **HOT** for a period of time afterwards. Use caution.
- Do not touch **HOT** surfaces. Use handles or knobs.
- Do not allow anyone to conduct activities around the electric smoker during or following its use until the unit has cooled.
- The use of alcohol, prescription or non-prescription drugs may impair the user's ability to properly assemble or safely operate the electric smoker.
- Avoid bumping or impacting the electric smoker.
- Never move the electric smoker when in use. Allow the smoker to cool completely before moving or storing.
- Be careful when removing food from the electric smoker. All surfaces are **HOT** and may cause burns. Use protective gloves or long, sturdy cooking tools.
- Avoid using the smoker on wooden or flammable surfaces.
- Store products indoors when not in use - out of reach of children.

## **WARNING**

### **CALIFORNIA PROPOSITION 65**

This product contains, or the use of this product releases, chemicals known to the State of California to cause cancer and birth defects or other reproductive harm. For more information go to [www.P65Warnings.ca.gov](http://www.P65Warnings.ca.gov).

**SAVE THESE INSTRUCTIONS**



# ***Congratulations***

on your purchase of your new  
Smoke Hollow® Digital Electric Smoker.

With proper set-up, operation and maintenance, this appliance will provide you with years of delicious food and cooking enjoyment.

## **IMPORTANT**

**When you un-pack your smoker, remove all parts and packaging material from the box and inside the smoker. Make sure you have all the items on the parts list. Carefully check the unit and make sure there is no damage.**

**IF YOU HAVE ANY PROBLEMS WITH THIS PRODUCT OR THERE ARE MISSING OR DAMAGED PARTS , PLEASE CALL CUSTOMER SERVICE TOLL FREE 1-866-475-5180 (Monday–Friday, 8:30 am–4:30 pm, CST).**

**NOTE : DO NOT RETURN UNIT TO THE STORE BEFORE CALLING THE TOLL FREE NUMBER.  
Do not dispose of your cartons until you are completely satisfied with your new Smoke Hollow smoker.**

### **THIS DEVICE COMPLIES WITH PART 15 OF THE FCC RULES**

**Warning:** Changes or modifications to this unit not expressly approved by the party responsible for compliance could void the user's authority to operate the equipment.

NOTE: This equipment has been tested and found to comply with the limits for a Class B digital device, pursuant to Part 15 of the FCC Rules. These limits are designed to provide reasonable protection against harmful interference in a residential installation. This equipment generates uses and can radiate radio frequency energy and, if not installed and used in accordance with the instructions, may cause harmful interference to radio communications. However, there is no guarantee that interference will not occur in a particular installation. If this equipment does cause harmful interference to radio or television reception, which can be determined by turning the equipment off and on, the user is encouraged to try to correct the interference by one or more of the following measures:

- **Reorient or relocate the receiving antenna.**
- **Increase the separation between the equipment and receiver.**
- **Connect the equipment into an outlet on a circuit different from that to which the receiver is connected.**
- **Consult the dealer or an experienced radio/TV technician for help.**

# Parts and Tool List

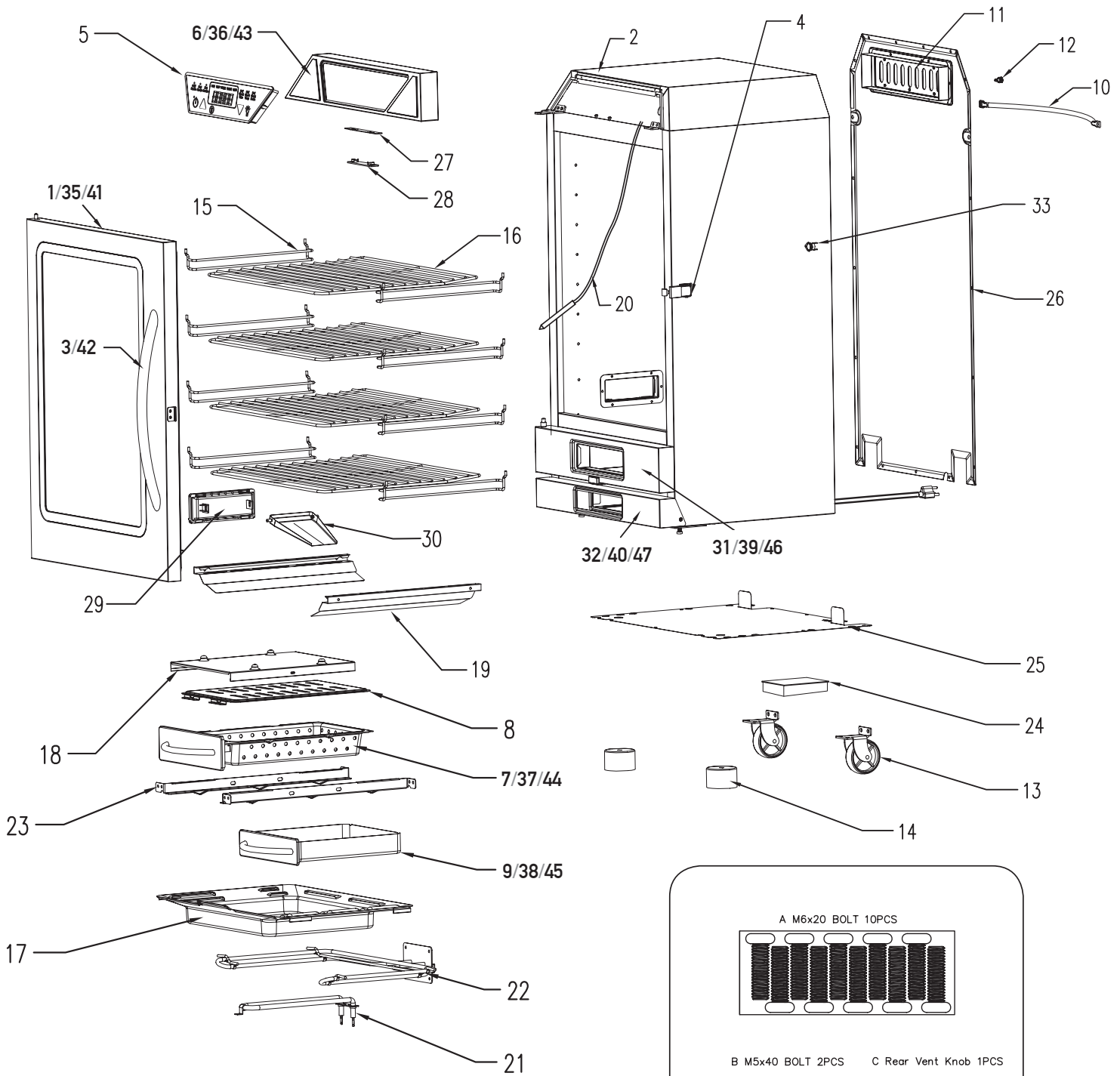

Tools needed for assembly:  
**Phillips head screwdriver**

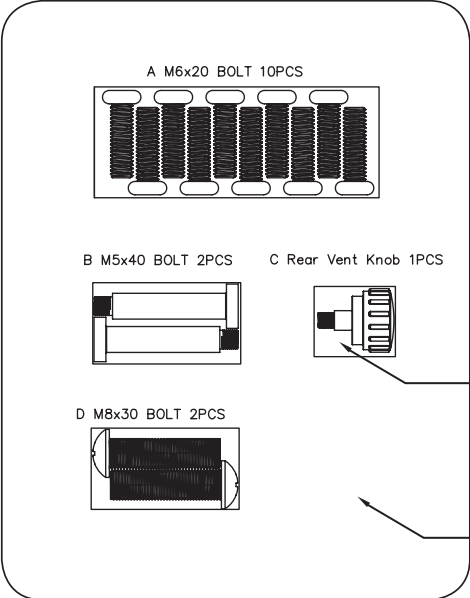

# Parts and Tool List

Note: For assistance, including missing or damaged parts, call toll free 1- 866-475-5180 from 8:30 am - 4:30 pm Central Time, Monday - Friday

Model Part #			Part Name	Qty.
D4015SS	D4015B	D4015R		
1	35	41	Smoker Door	1
2	2	2	Smoker Cabinet	1
3	3	42	Door Handle	1
4	4	4	Door Latch	1
5	5	5	Controller	1
6	36	43	Control Panel	1
7	37	44	Wood Chip Tray Assembly	1
8	8	8	Wood Chip Tray Lid	1
9	38	45	Grease Tray	1
10	10	10	Rear Handle	1
11	11	11	Rear Vent	1
12	12	12	Rear Vent Knob	1
13	13	13	Wheel Assembly	2
14	14	14	Foot Pads	2
15	15	15	Grid Tracks	8
16	16	16	Cooking Grids	4
17	17	17	Water Pan	1
18	18	18	Wood Chip Tray Cover	1
19	19	19	Reflector Plate Rail	2
20	20	20	Meat Probe	1
21	21	21	Smoke Element	1
22	22	22	Heat Element	1
23	23	23	Wood Chip Tray Rails	2
24	24	24	Power Circuit Board	1
25	25	25	Bottom Panel	1
26	26	26	Back Panel	1
27	27	27	LED Light	1
28	28	28	Lense – LED Light	1
29	29	29	Water Pan Door	1
30	30	30	Water Pan Spout	1
31	39	46	Wood Chip Tray Lower Panel	1
32	40	47	Grease Tray Lower Panel	1
33	33	33	High Temp Limiter	1
34	34	34	Hardware Pack	1

# Smoker Assembly

## Step 1

### Locate:

- Cabinet Assembly
- (2) Wheels
- (2) Front Pads
- (2) M8 x 30 bolts
- (8) M6 x 20 bolts

### Tools Needed:

Phillips Screwdriver

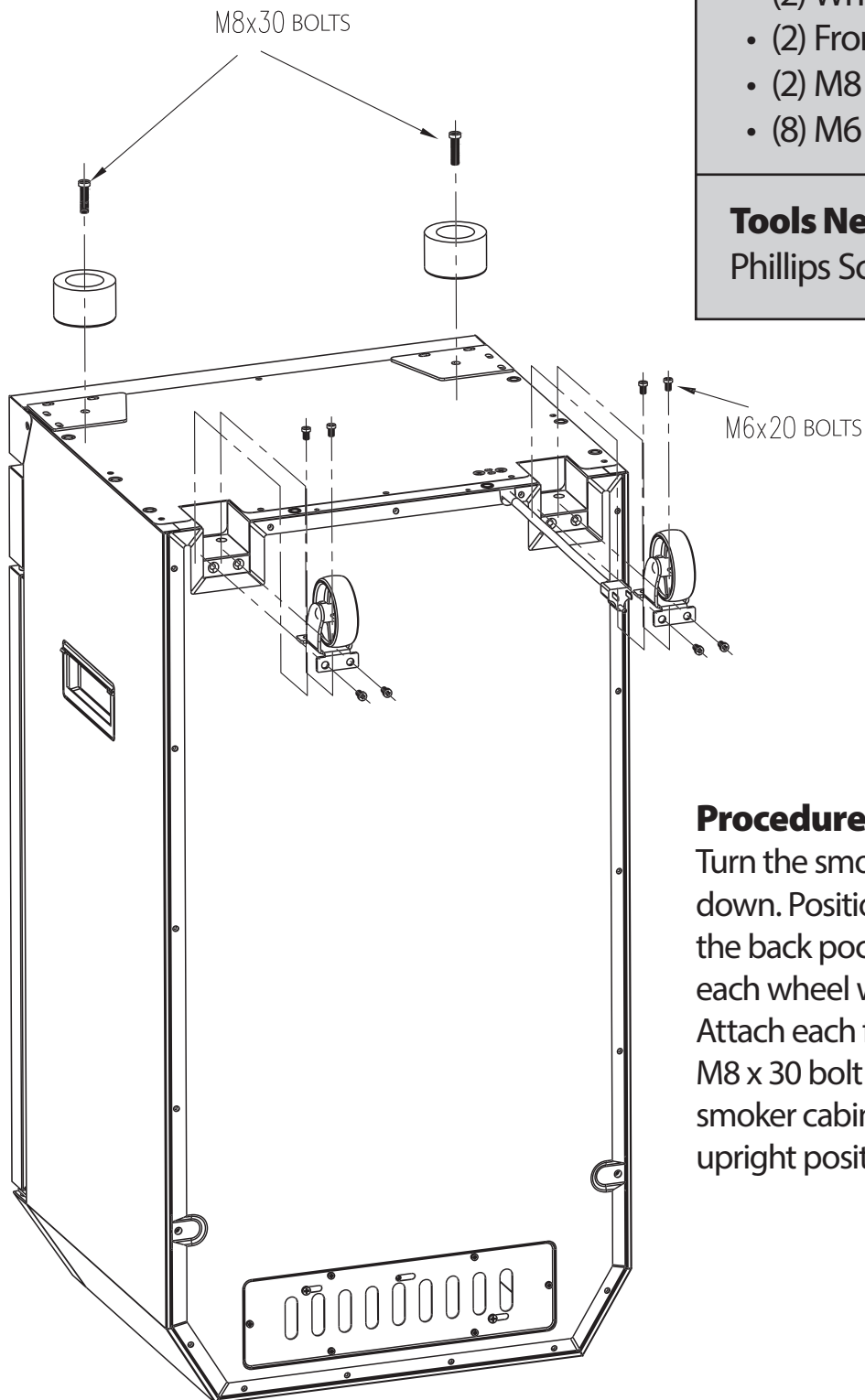

### Procedure:

Turn the smoker cabinet upside down. Position the wheels into the back pockets as shown. Fasten each wheel with (4) M6 x 20 bolts. Attach each front pad with a M8 x 30 bolt as shown. Return smoker cabinet to it's normal upright position.



# Smoker Assembly

## Step 2

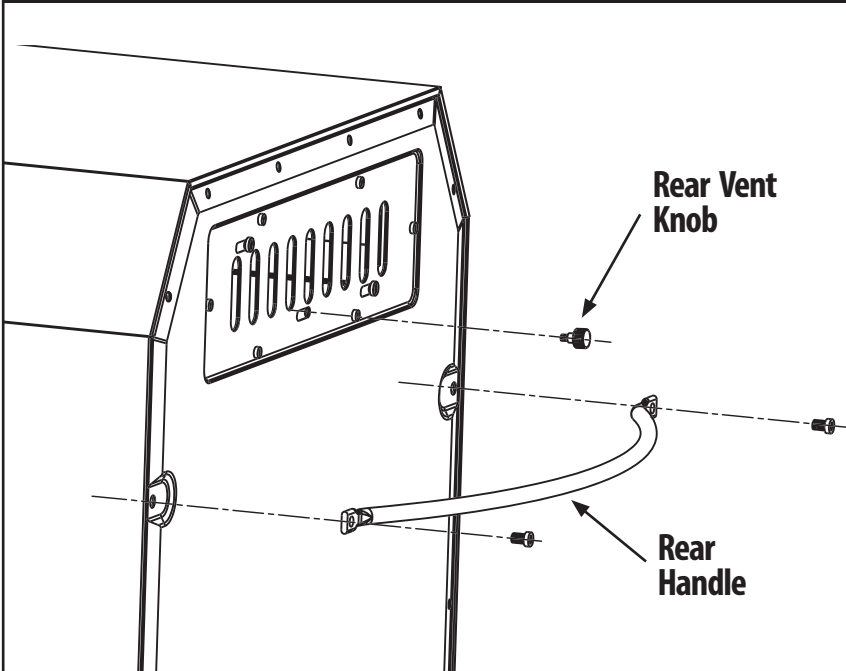

### Locate:

- Rear Handle
- Rear Vent Knob
- (2) M6 x 20 bolts

### Tools Needed:

Phillips Screwdriver

### Procedure:

Use (2) M6 x 20 bolts to assemble the Rear Handle to the smoker cabinet. Screw the Vent Knob to the Rear Vent as shown.

*Note: Hand tighten knob.*

## Step 3

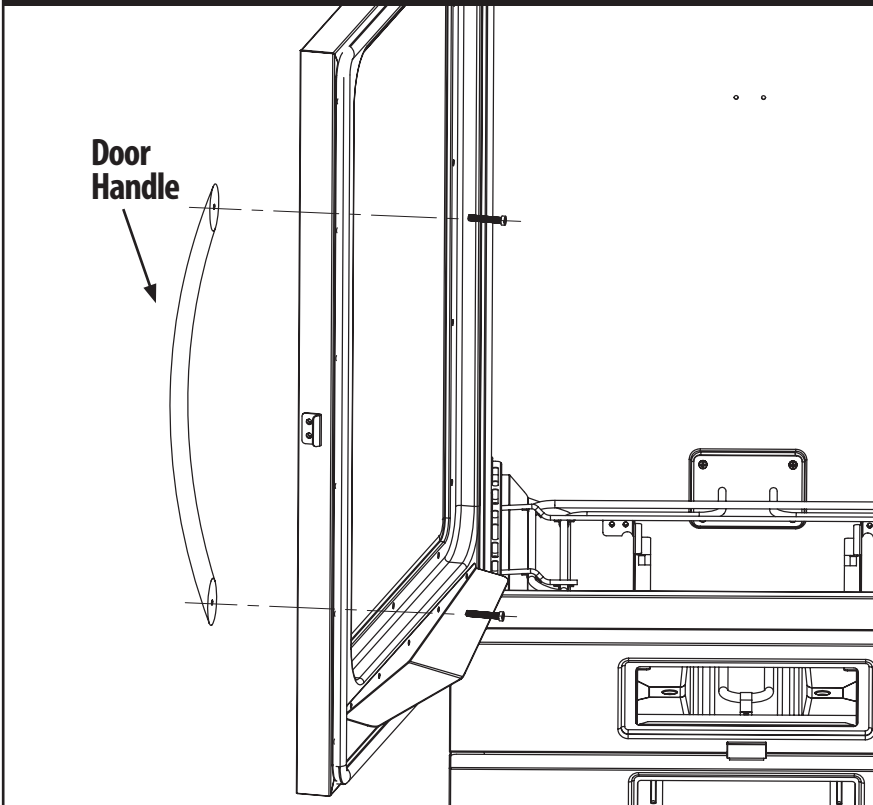

### Locate:

- Door Handle
- (2) M5 x 40 bolts

### Tools Needed:

Phillips Screwdriver

### Procedure:

Use (2) M5 x 40 bolts to assemble the Door Handle as shown.

# Smoker Assembly

## Step 4

### Locate:

- Wood Chip Tray Cover
- Water Pan

### Tools Needed:

None

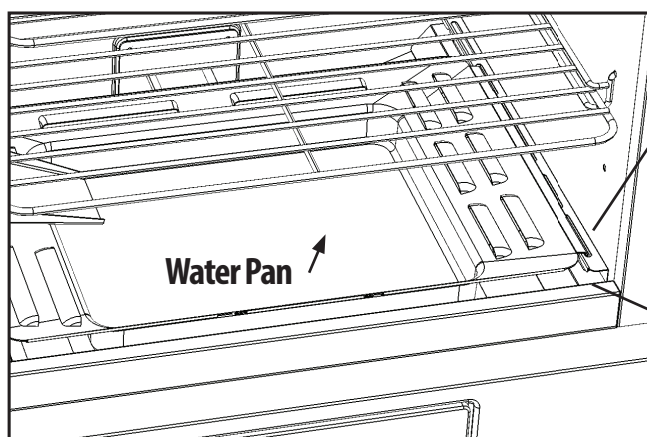
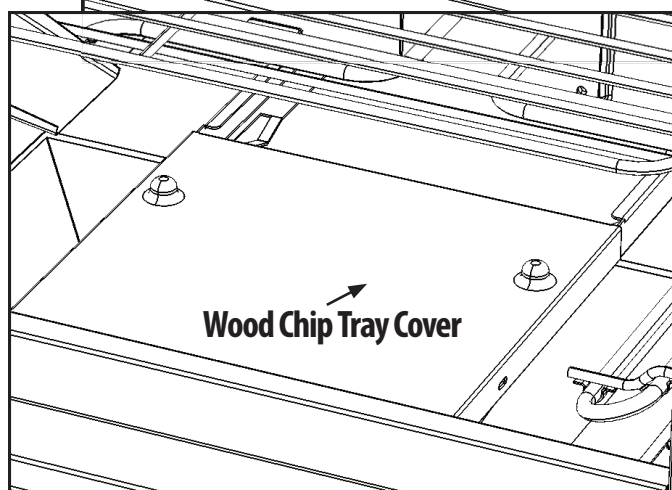
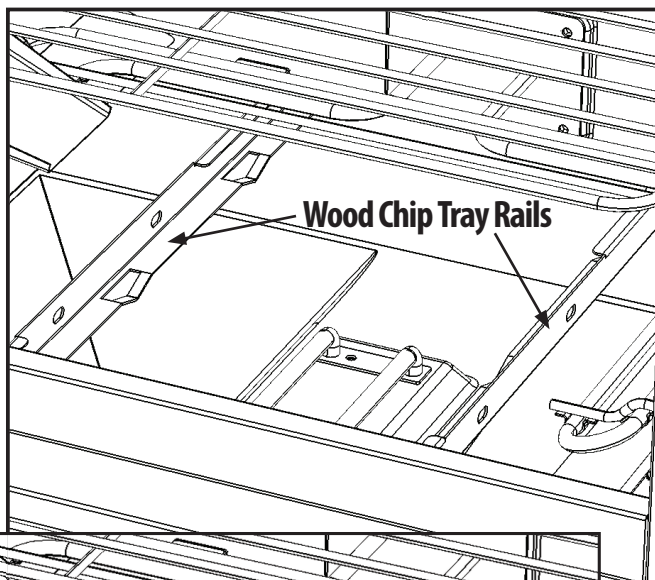

### Procedure:

Position the wood chip tray cover over the (2) wood chip tray rails inside the smoker. The dimples on the side of the wood chip tray cover should sit into the recesses in the wood chip tray rails.

Position the water pan onto the reflector plate rails on the sides of the smoker as shown. The tabs on the sides of the water pan will fit into the slots in the reflector rails as shown.

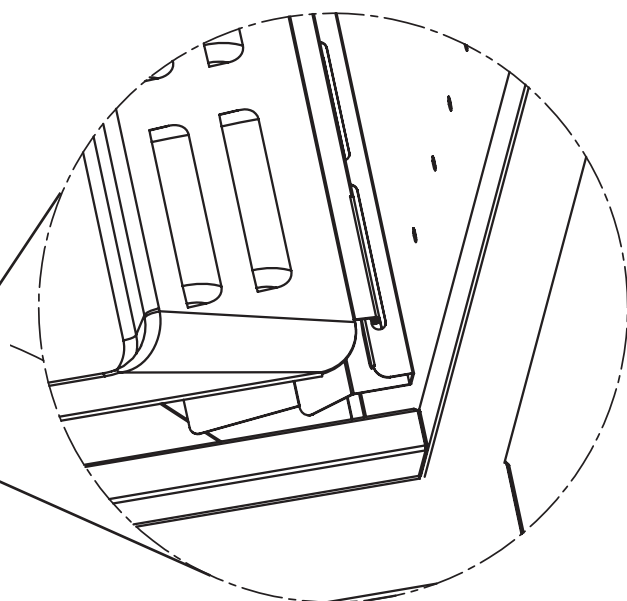

# Smoker Assembly

## Step 5

### Locate:

- Water Pan Spout
- (8) Grid Supports

### Tools Needed:

None

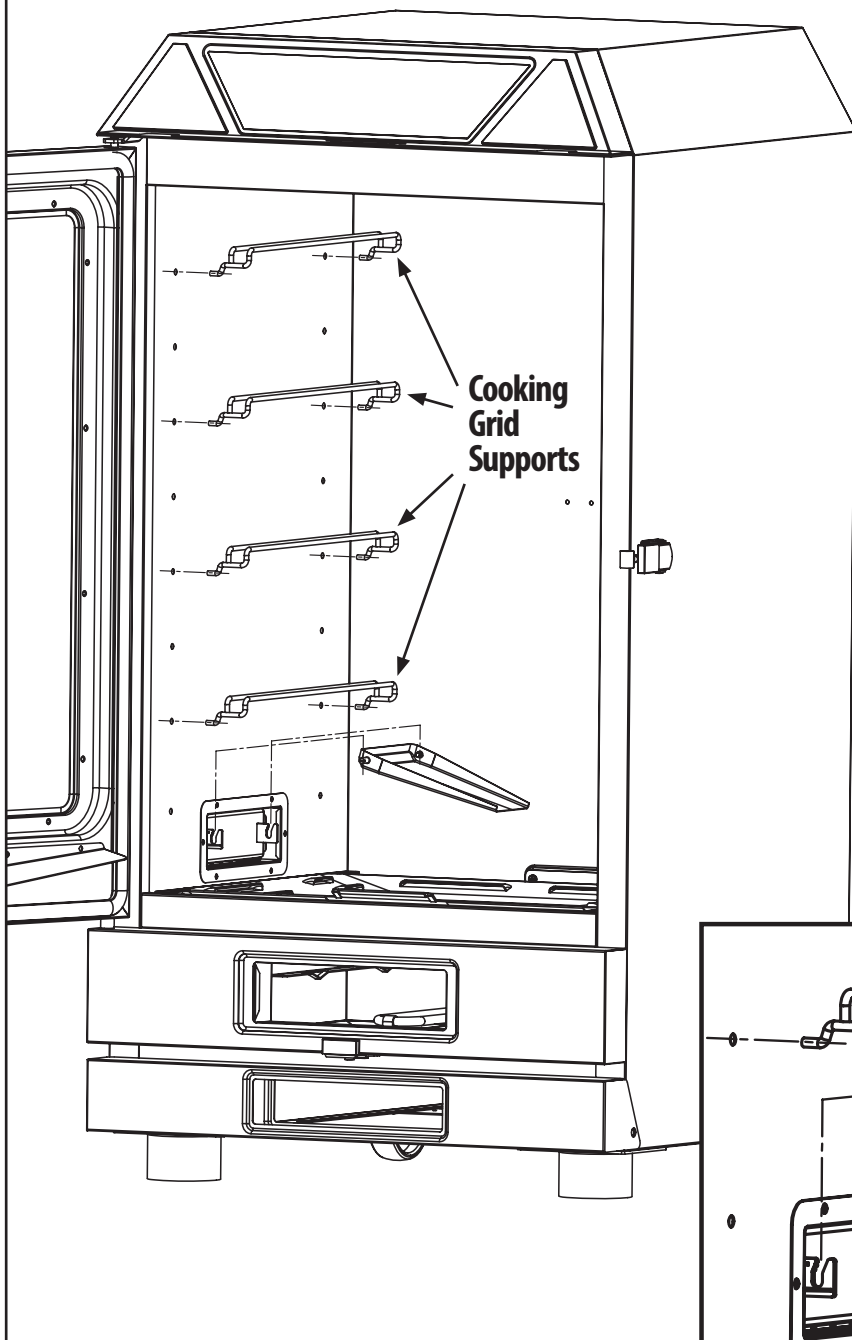

### Procedure:

Assemble (4) grid supports in the holes in the left side of the smoker. Repeat the procedure for the right side making sure the grid supports on the left side and right side are at the same height so the cooking grids are level.

Assemble the water pan spout to the water pan door as shown below.

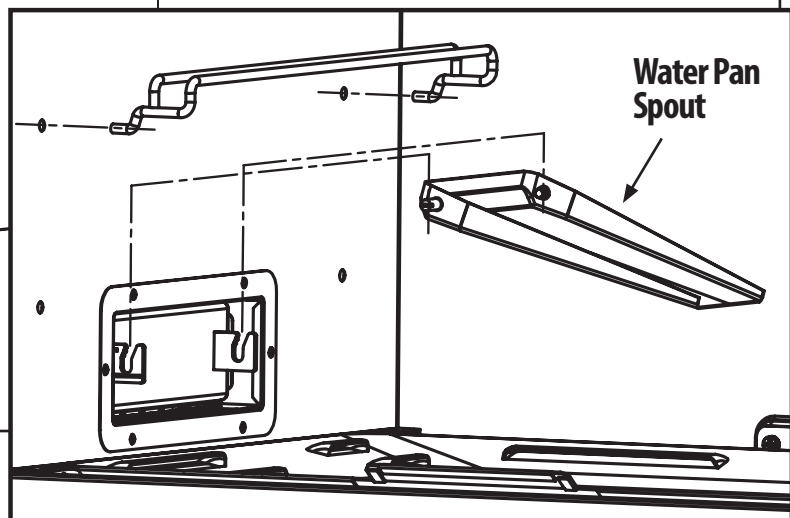

# Smoker Assembly

## Step 6

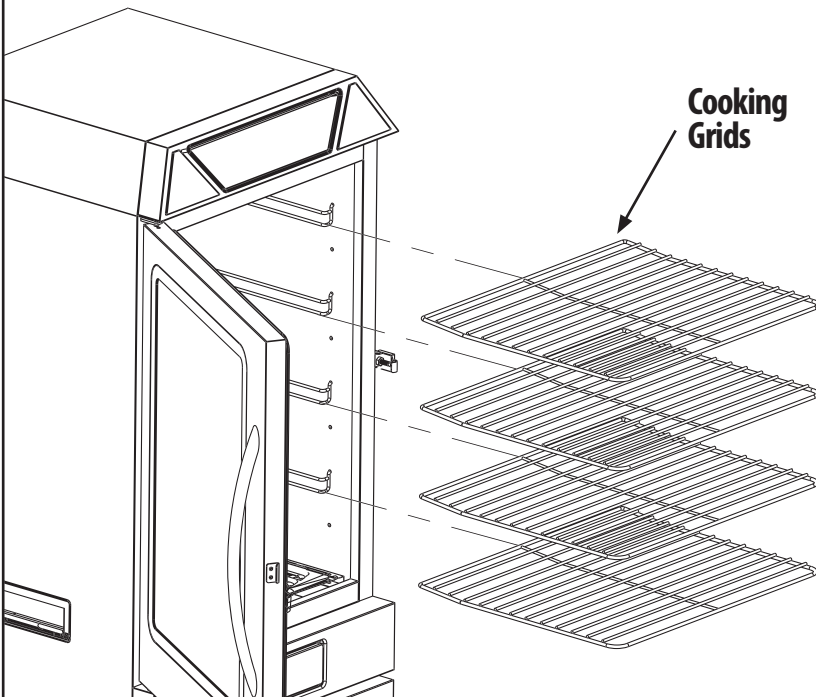

### Locate:

- (4) Cooking Grids

### Tools Needed:

None

### Procedure:

Place the (4) cooking grids into the cooking grid supports as shown. Make sure the angled portion of the grid is slid in first.

## Step 7

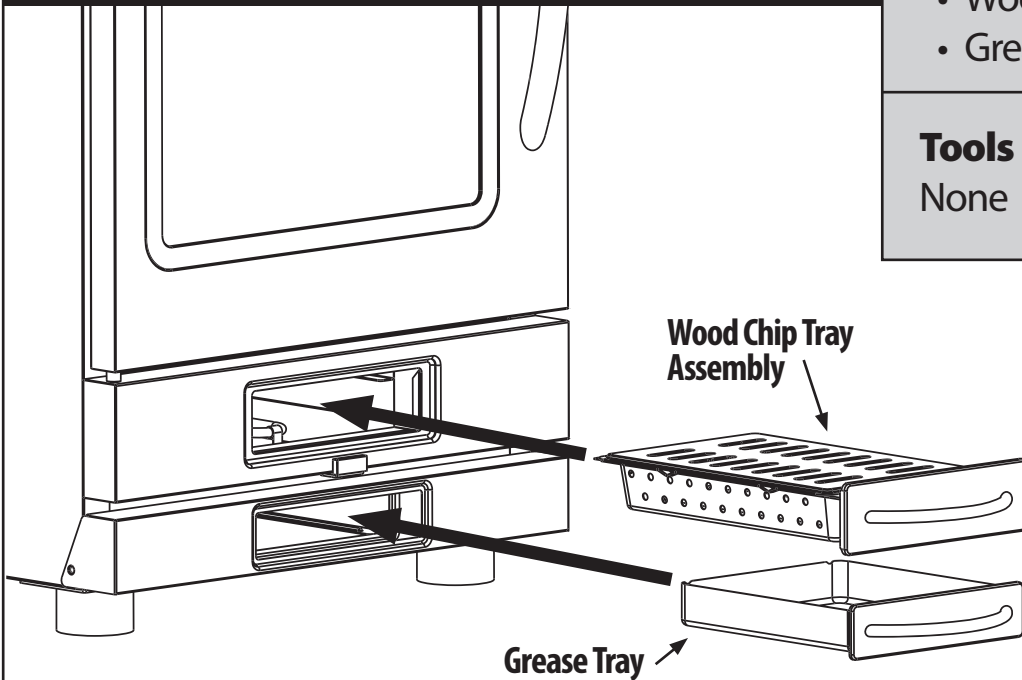

### Locate:

- Wood Chip Tray Assembly
- Grease Tray

### Tools Needed:

None

### Procedure:

Slide the wood chip tray assembly into the rails in the smoker. Slide the grease tray into the opening on the smoker as shown.

# Smoker Assembly

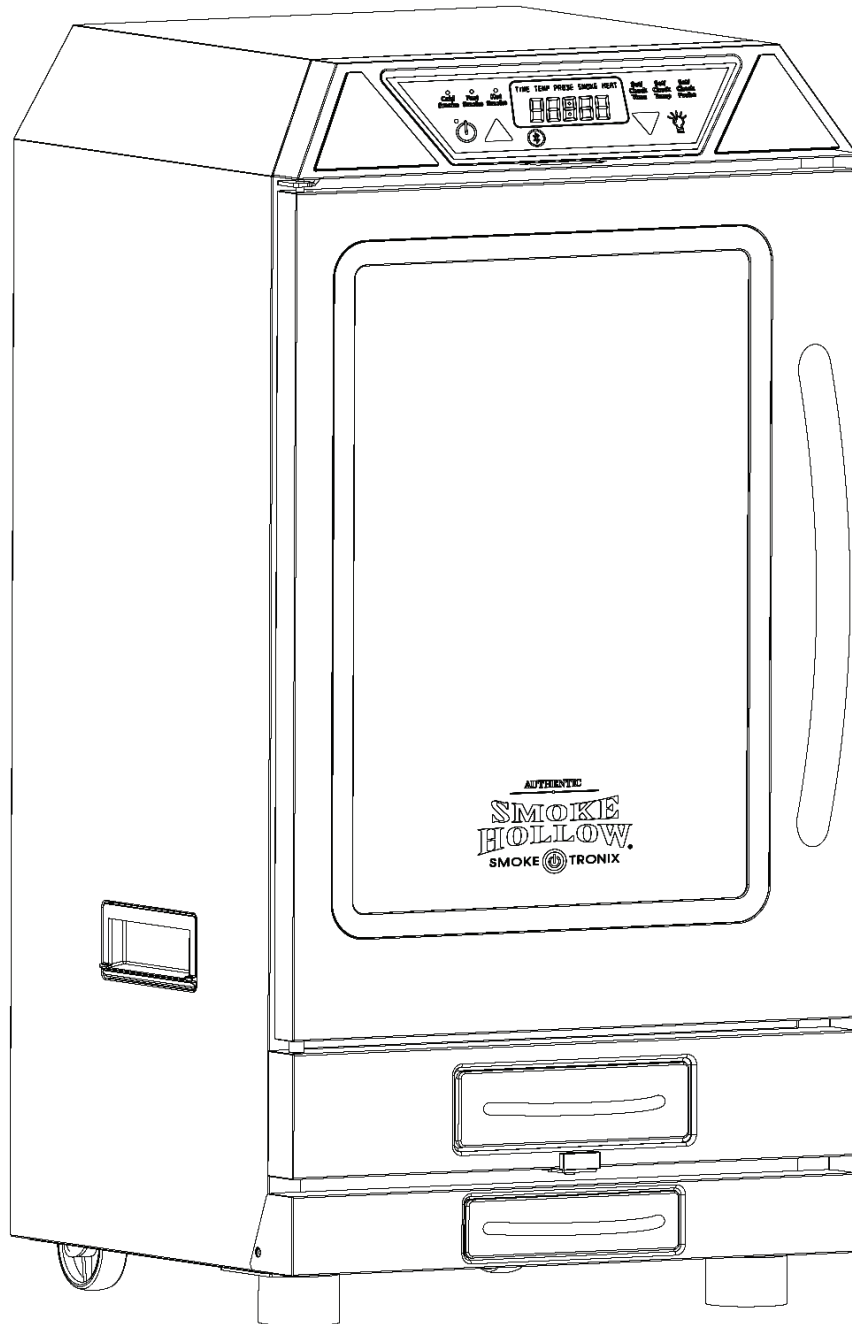

**ASSEMBLY OF YOUR SMOKER IS NOW COMPLETE.  
FOR YOUR SAFETY, FOLLOW ALL SAFE GUARDS  
AND INSTRUCTIONS.**

# Seasoning Instructions

SEASON YOUR SMOKER PRIOR TO ITS FIRST USE.  
SOME SMOKE MAY APPEAR DURING THIS TIME. THIS IS NORMAL  
DURING THE SEASONING PROCESS.

1. Make sure water pan is in place with NO WATER.
2. Turn on smoker-set temperature to 275°F and set time for 3 hours.
3. To complete the seasoning process, add wood chips to the wood chip tray during the last 45 minutes.

**Caution: Never overfill the wood chip tray. Make sure the wood chip tray lid closes completely.**

4. Shut the unit off and allow to cool.

## How to Use The Wood Chip Tray

1. Fill wood chips into wood chip tray before starting the unit

**Caution: Never overfill the wood chip tray. Make sure the wood chip tray's lid closes completely on the tray.**

2. Never use wood chunks or wood pellets in wood chip tray.
3. Insert the wood chip tray in place.
4. Check wood chip tray periodically to see if wood chips have charred down by sliding wood chip tray out half way and look through slots on wood chip tray cover.
5. If wood chips have completely charred then remove the tray from the smoker.

**Caution: The wood chip tray and lid will be HOT, even if the handle is not.**

6. Dump the burned wood chips in a metal pan with water to extinguish the wood chips.
7. Repeat steps when changing wood chip tray then push fast smoke.

**Caution: Always keep smoker door closed when removing or adding wood chips.**

### ⚠ CAUTION ⚠

FLARE UPS MAY OCCUR WHEN PULLING OUT WOOD CHIP TRAY. IMMEDIATELY PUSH WOOD CHIP TRAY BACK INSIDE AND WAIT UNTIL WOOD CHIPS ARE CHARRED DOWN, THEN CHECK WOOD CHIPS AGAIN. DO NOT SPRAY BURNING WOOD CHIPS WITH WATER.

# Important Facts for Using Smoker

- Maximum temperature setting is 290°F (143°C).
- When moving the smoker across uneven surfaces, do with caution as it may cause damage.
- DO NOT USE Rear handle for lifting.
- Wood chip tray's lid MUST be in place when using smoker. This minimizes the chance of wood flare ups.
- Wood chips must be used in order to produce smoke and create the smoke flavor.
- Check grease tray often during cooking. Empty grease tray before it gets full. Grease tray may need to be emptied periodically during cooking.
- Do not open smoker door unless necessary. Opening smoker door causes heat to escape and may cause wood chips to flare up. Keep door closed to maintain cooking temperature and avoid flare ups.
- If a flare up occurs in your wood chip tray, leave the door closed and close the lower air intake vent until flare up stops. If the flare up continues for 10 or more minutes, shut the smoker off to allow the flare up to stop.
- Do not leave old wood ashes in the wood chip tray. Once ashes are cold, empty tray. Tray should be cleaned out prior to, and after each use to prevent ash buildup.
- Glass in door is tempered and will not break under normal operation.
- Opening smoker door during cooking process may extend cooking time due to heat loss.
- When outside temperature is cooler than 65°F (18°C) and/or altitude is above 3,500 feet (1,067m), additional cooking time may be required. To ensure that meat is completely cooked use a meat thermometer to test internal temperature.
- This is a smoker. There will be a lot of smoke produced when using wood chips. Some smoke may escape through seams and turn the inside of smoker black. This is normal. To minimize smoke loss around door, the door latch can be adjusted to further tighten door seal against body.
- To adjust door latch, loosen hex nut on door latch. Turn hook clockwise to tighten. Secure hex nut firmly against door latch.

## How to Clean Smoker

**WARNING: ALWAYS MAKE SURE UNIT IS UNPLUGGED AND COOL TO THE TOUCH BEFORE CLEANING AND STORING.**

- For the grid tracks, cooking grids, water pan and grease drip tray, use a mild dish detergent. Rinse and dry thoroughly.
- For the wood chip tray, clean frequently to remove ash build up, residue and dust.
- Dispose of cold ashes by placing them in aluminum foil, soaking with water and discarding in a non-combustible container.
- For the interior (glass in door and meat probe) and exterior of the smoker, simply wipe down with a damp cloth. Make sure to dry thoroughly. Note: Do not use a cleaning agent on the interior.
- Door seal and inside seam that seal attaches to MUST be cleaned with a damp cloth after each use to keep seal in proper working condition.

# Operating Instructions

## Control Panel Operations

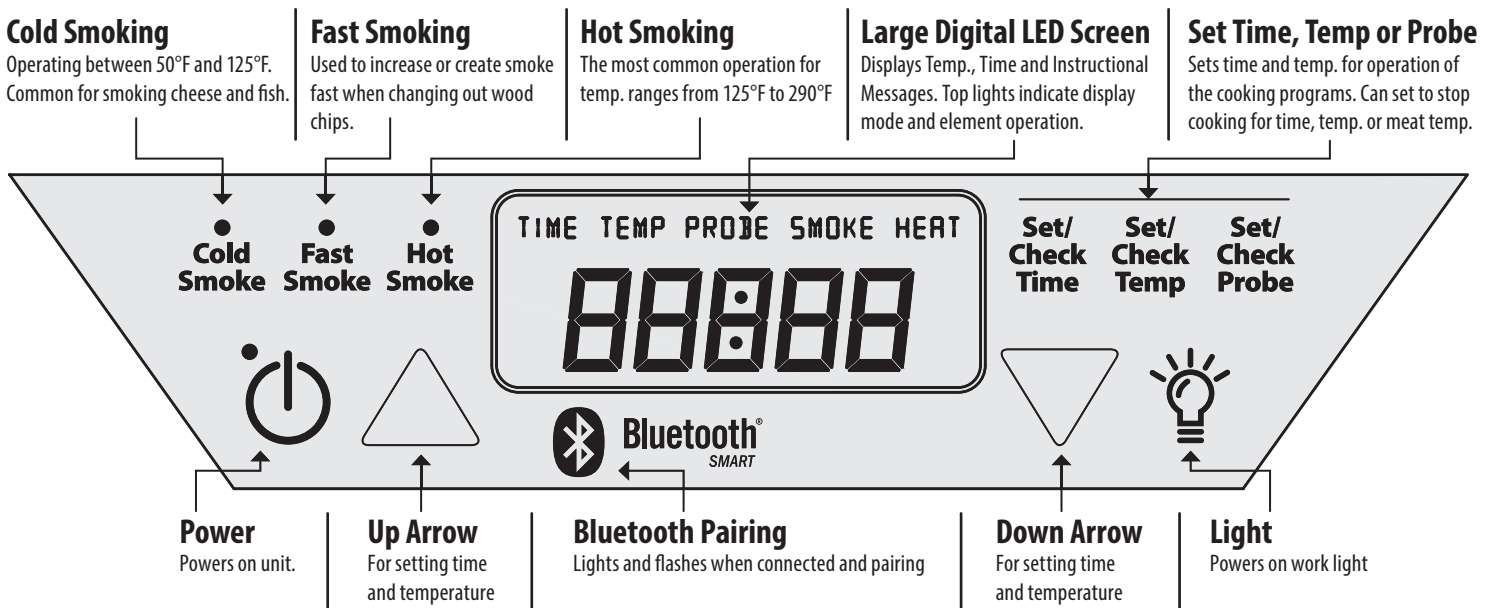

## Control Panel Functions



The **POWER** button powers the unit on. When the power cord is plugged in, the blue LED light will flash indicating the unit has power. When the POWER button is pushed the unit will turn on and the light will stay on.



The **BLUETOOTH PAIRING** button has a blue LED indicator light that will flash during the pairing operation and will remain solid lit when paired. (The Bluetooth will pair when the unit is plugged in). If for any reason the unit does not go into pair mode, the Bluetooth button can be pushed to place the unit into pairing mode.



When the **COLD SMOKE** button is pressed, the LED light will flash during the program set up. When the program is in operation, the LED light will turn solid. The COLD SMOKE button allows you to operate between the temperatures of 50°F and 125°F. You are able to set your smoking time, smoking temperature and probe temperature after the COLD SMOKE button is pushed. Outside temperatures may affect your ability to cold smoke. If your internal temperature in your smoker is higher than 125°F, the LED screen will inform you that your unit is too hot by displaying "2-hot".



When the **FAST SMOKE** button is pressed, the LED light will turn solid while the program is in operation. The FAST SMOKE button serves (2) functions.

1. To get the wood chips smoking faster when you are in either COLD or HOT SMOKE programs.
2. To get new wood chips started faster after replacing burned up wood chips.

The FAST SMOKE can be used anytime after the initial 20 minutes during the smoking functions. NOTE: FAST SMOKE mode is preset to run for 20 minutes. The LED display starts at 20 minutes and counts down to zero. The current smoking program is still running in the background during the 20 minutes the FAST SMOKE is in use. After the 20 minutes the smoking program will resume. The FAST SMOKE can be stopped at any time during the running of the program by pressing the FAST SMOKE button again.



When the **HOT SMOKE** button is pressed, the LED light will flash during the program set up. When the program is in operation the LED light will turn solid. The HOT SMOKE button allows you to operate between the temperatures of 125°F to 290°F. You are able to set your smoking time, smoking temperature and probe temperature after the HOT SMOKE button is pushed. Outside temperatures may affect your internal temperatures during the hot smoke program.

CAUTION: the smoker will automatically shut off when internal temperature is higher than 302°F and will automatically start operating again once the temperature is under the 290°F.



# Operating Instructions

## Set/ Check Time

The **SET/CHECK TIME** button allows you to set your smoking time from 1 hour to 99 hours. You are also able to check the time left to smoke during any smoke program by pressing the SET/CHECK TIME button once. Your time will change in 1 hour increments with pressing the SET/CHECK TIME button one time. After you have set your hours, if you press the SET/CHECK TIME button again you will be able to set the minutes for your smoking cycle. Your minutes will change in 10 minute increments.

## Set/ Check Temp

The **SET/CHECK TEMP** button allows you to set your desired smoking temperature in the smoking programs. You will be able to set your temperature range in the Cold Smoking program between 50°F and 125°F and in the Hot Smoking program between 125°F and 290°F. You are able to check your internal temperature inside the smoker at any time during any of the smoking programs by pressing the SET/CHECK TEMP button once. Your temperature will change in 5°F increments when setting the internal smoker temperature.

## Set/ Check Probe

The **SET/CHECK PROBE** button allows you to set your desired meat probe temperature in the smoke programs. You will be able to set your meat probe temperature range in both Smoke programs between 50°F and 300°F. To check your meat probe temperature at any time during the smoke programs, press the SET/CHECK PROBE button once. Your temperature will change in 5°F increments when setting the meat probe temperature. Once the meat probe reaches the set temperature, there will be an alert sound for 3 seconds to notify you that the meat probe has reached the set temperature. NOTE: The probe will not disengage the elements.



The **ARROW CONTROL** buttons allow you to change the time and temperature up and down accordingly. When you press the UP/DOWN ARROW button, the time will change in 1 hour increments or 10 minute increments and the temperature will change in 5 degree increments. If you press and hold the UP/DOWN ARROW button for 3 seconds or longer, the time and temperature will scroll at a faster rate.



When the **LIGHT** button is pressed the LED light under the control panel will power on. When the button is pressed a second time the LED light will power off.

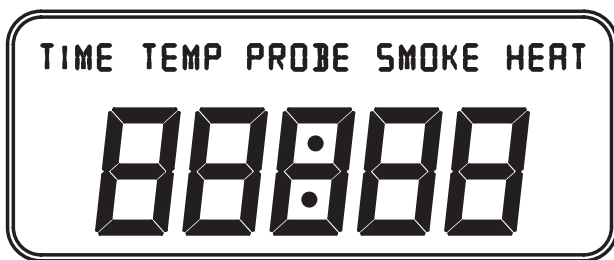

The **DIGITAL LED SCREEN** is your information center for the smoker. The LED screen will display your Time, Temperature and Meat Probe Temperatures you have set. When you have chosen a smoking mode and set your information, the LED screen will scroll between Time, Temperature and Meat Probe Temperature during the smoking cycle.

There are 5 displays above the LED screen, Time, Temp, Probe, Smoke and Heat. When these modes are operational, the individual display will be lit to indicate they are operating.

1. The **"TIME"** will be lit on the controller when you are setting the time in the program modes and when the LED screen is scrolling and the remaining time appears on the screen.
2. The **"TEMP"** will be lit on the controller when you are setting the temperature in the program modes and when the LED screen is scrolling and the temperature appears on the screen.
3. The **"PROBE"** will be lit on the controller when you are setting the meat probe temperature in the program modes and when the LED screen is scrolling and the meat probe temperature appears on the screen.
4. The **"SMOKE"** will be lit on the controller when the smoke element is turned on during the program modes and when the "FAST SMOKE" is on.
5. The **"HEAT"** will be lit on the controller when the heat element is turned on during the program modes.

# Operating Instructions

1. Plug the power cord into a GFI Outlet. The blue indicator light on the POWER button will flash indicating there is power to the smoker.
2. Push the POWER button to turn the smoker ON. There will be an alert sound for 3 seconds and the LED screen will light up indicating the smoker is ready to use. The LED screen will then scroll between "TIME", "TEMP" (Internal Smoker Temperature) and "PROBE" (Meat Probe Temperature)
3. Open side water fill door and fill water pan half full with water. (During your smoking process, you can add additional water through the side water fill door. - Note: Do not overfill.)
4. Fill the wood chip tray with wood chips. Refer to the section "How to use the wood chip tray" on page 13
5. Press either the "HOT SMOKE" or "COLD SMOKE" button to set your smoking program preference.
6. Press the "SET/CHECK TIME" button to set the smoking cycle time.
  - Press the button once to set hours.
  - Press the UP or DOWN arrow to increase or decrease the hours.
  - Press the button again to set minutes.
  - Press the UP or DOWN arrow to increase or decrease the minutes.
7. Press the "SET/CHECK TEMP" button to set the time and to set the desired temperature inside the smoker.
  - Press the UP or DOWN arrow to increase or decrease temperature.
8. Press the "SET/CHECK PROBE" button to set the smoker temperature and to set the desired meat probe temperature. - Press the UP or DOWN arrow to increase or decrease the desired meat probe temperature.
9. Press the "HOT SMOKE" or "COLD SMOKE" button again to start your smoking program.
10. When you are in a "HOT SMOKE" or "COLD SMOKE" program, your LED screen will scroll between the time left to smoke, the internal temperature of the smoker and the meat probe temperature. When the program time runs out, the smoker will shut off. When the meat reaches the set temperature on the meat probe, there will be an alert sound for 3 seconds indicating that the meat is done. Note: The smoker will still be running and the LED screen will display time, temp and the probe temp.

NOTE: If at any time the consumer presses the Check Time, Temp or Probe button, the display will change to the current time remaining, the current temperature or the current probe temperature. By holding the Set Time or Temp button for 3 seconds during the hot or cold smoke cycle, the LED will flash the current set time or temperature. The time or temperature can be changed by using the up and down arrows as defined above. The change can be confirmed by pressing the set button a second time.

11. Your wood chips should start to smoke in 10 - 15 minutes depending on the type of wood chips. After 20 minutes your wood chips should "Wick" and continue to smoke for the rest of the program cycle. Below is a chart with recommended settings for both of the air intakes (Vents) on the smoker.

Recommended Air Intake Settings		Smoke Programs	
		For <b>HOT</b> Smoke	For <b>COLD</b> Smoke
Back Air Vent	First 20 Minutes	Open 100%	Open 100%
	Rest of Program	Open 50%	Open 100%
Bottom Air Vent	First 20 Minutes	Open 100%	Open 100%
	Rest of Program	Set to any position for desired amount of smoke	Set to any position for desired amount of smoke

NOTE: If you feel your wood chips are not producing enough smoke after the initial 20 minutes, press the "FAST SMOKE" button and the smoke element will run for an additional 20 minutes to help get the wood chips smoking. On the LED screen you will see the time counting down from 20 minutes to zero. You can stop the "FAST SMOKE" program at any time by pressing the "FAST SMOKE" button while the program is running.

NOTE: You can set your Air Intake to any opening to achieve your optimal smoke you desire. These are recommended settings to help your chips to last longer and have optimal smoke generated. (Your settings may vary depending on the size of the wood chips used and the density of the wood chips in the wood chip tray.)

NOTE: If your wood chips are producing more smoke than you want, you can slow the smoke being produced by decreasing the lower air intake vent opening to restrict the incoming air.

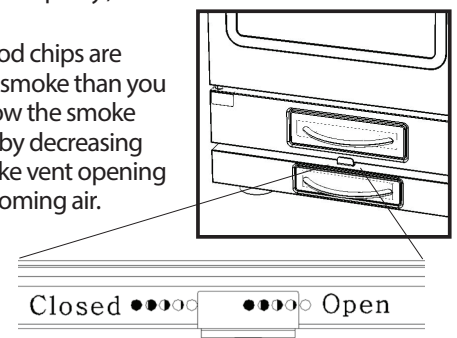

# Troubleshooting Guide

<b>SYMPTOM</b>	<b>CAUSE</b>	<b>SOLUTION</b>
<b>No Power to controller (No Beep when plugged into outlet)</b>	Not plugged into outlet	Plug into power source
	House breaker tripped	Reset breaker
	Bad connection at controller	Unplug connection and reconnect. Reference how to access/replace controller instructions
	Bad connection at PCB (Power Control Board)	Unplug connection and reconnect. Reference how to access/replace PCB instructions
	Faulty PCB (Power Control Board)	Call OLPI for replacement. Reference how to access/replace PCB instructions
	Faulty Controller	Call OLPI for replacement. Reference how to access/replace controller instructions
	Faulty body wiring	Call OLPI for replacement.
<b>Power light not on (Controller beeps when plugged in)</b>	Appliance not powered on	Press on/off button
	Faulty controller	Call OLPI for replacement. Reference how to access/replace controller instructions
<b>No display on controller (Power light is on)</b>	Controller temp is below -10°F (-23°C)	Remove controller from unit and bring to temp above 0°F (-18°C)
	Faulty controller	Call OLPI for replacement. Reference how to access/replace controller instructions
<b>Heating light not on</b>	Smoking program not set	Set Temp and Time in smoking program, wait 60 seconds for heating
	Faulty controller	Call OLPI for replacement. Reference how to access/replace controller instructions
	Faulty body wiring	Call OLPI for replacement.
<b>Element not on</b>	Bad connection at HTL how to access/replace HTL instructions	Unplug connection and reconnect. Reference
	Bad connection at the element	Unplug connection and reconnect. Reference how to access/replace element instructions
	Faulty HTL (High Temp Limit Safety Shut-off)	Call OLPI for replacement. Reference how to access/replace HTL instructions
	Faulty element	Call OLPI for replacement. Reference how to access/replace element instructions
<b>Meat Probe does not read on controller</b>	Bad connection at the meat probe	Unplug connection and reconnect. Reference how to access/replace meat probe instructions
	Faulty meat probe	Call OLPI for replacement. Reference how to access/replace meat probe instructions
	Faulty controller	Call OLPI for replacement. Reference how to access/replace controller instructions

# Troubleshooting Guide

SYMPTOM	CAUSE	SOLUTION
Cabinet Temp is inaccurate	Faulty HTL (High Temp Safety Limit Shut-off)	Call OLPI for replacement. Reference how to access/replace HTL
	Faulty controller	Call OLPI for replacement. Reference how to access/replace controller instructions
Appliance takes excessive amount of time to heat	Climate	Temps below 65°F (18°C) may extend heating time
	Appliance plugged into an extension cord	Plug appliance directly into power source. Maximum length ext. cord 25ft, min. gauge 12/3
	Door not closed properly	Close door and adjust latch so door seals completely
	Waterbowl/ Drip deflector not properly located	Locate waterbowl/drip deflector properly on supports See assembly steps for proper installation
	Faulty controller	Call OLPI for replacement. Reference how to access/replace controller instructions
Gap between the door and smoker	Door alignment	Adjust door hinges
	Damaged door seal	Call OLPI for replacement door kit
Grease leaking from smoker	Door not closed properly	Close door and adjust latch so door seals completely around appliance
	Appliance not level	Move appliance to level surface and adjust height
	Water pan not in proper location	Align water pan so grease from door goes into water pan
	Grease tray is full	Empty grease tray and reinstall under smoker
	Drain holes are clogged inside smoker	Clean drain holes in smoker bottom
No smoke	No wood chips	Add wood chips. (See adding wood chips guide)
	Smoke element not staying on long enough to heat chips due to climate	Open both the back vent and the lower vent fully. Push the fast smoke button to engage the smoke element
	Damaged smoke tray	Call OLPI for replacement.
Controller will not adjust temp	Faulty controller	Call OLPI for replacement. Reference how to access/replace controller instructions
Controller will not adjust time	Faulty controller	Call OLPI for replacement. Reference how to access/replace controller instructions
Error Code: Err	Thermostat probe is damaged/short circuited	Call OLPI for replacement
	Meat probe is damaged/short circuited	Call OLPI for replacement. Reference how to access/replace meat probe instructions
	Faulty controller	Call OLPI for replacement. Reference how to access/replace controller instructions

# Part Replacement Guide

## Heat Element Access/Replacement

### Removal:

1. Make sure smoker is turned OFF and is unplugged from the electrical outlet
2. Remove all cooking grids and water pan from smoker
3. Remove rear handle - (2) screws - (Figure A1)
4. Remove rear vent - (6) screws - (Figure A2)
5. Remove back panel - (17) screws - (Figure A1)
6. Unscrew wires from Heat Element - (Figure A3)
7. Remove (4) screws from element bracket from inside smoker - (Figure A4)
8. Remove heat element from inside smoker

**Tools Needed:** Phillips Screwdriver

### Installation:

9. Place new heat element into smoker and secure with (4) screws previously removed.
10. Re-screw wires onto new heat element from back of smoker
11. Reattach rear panel - (17) screws
12. Reattach rear vent - (6) screws
13. Reattach Rear Handle - (2) screws
14. Place water pan and cooking grids back into smoker.
15. Plug smoker back into an electrical outlet

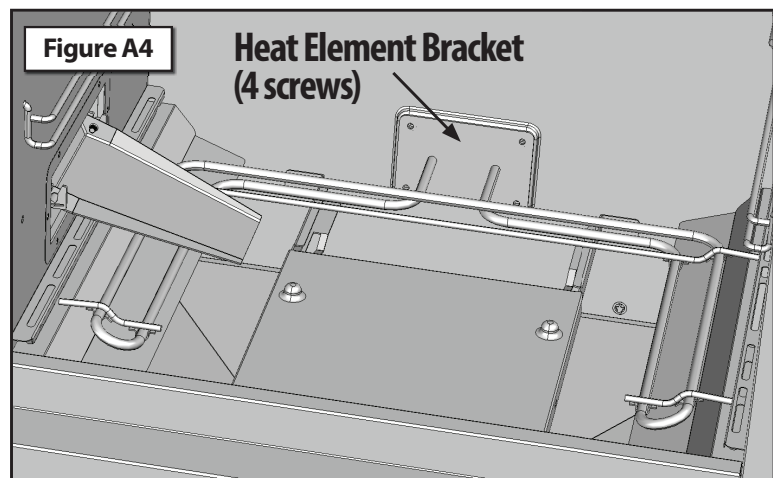
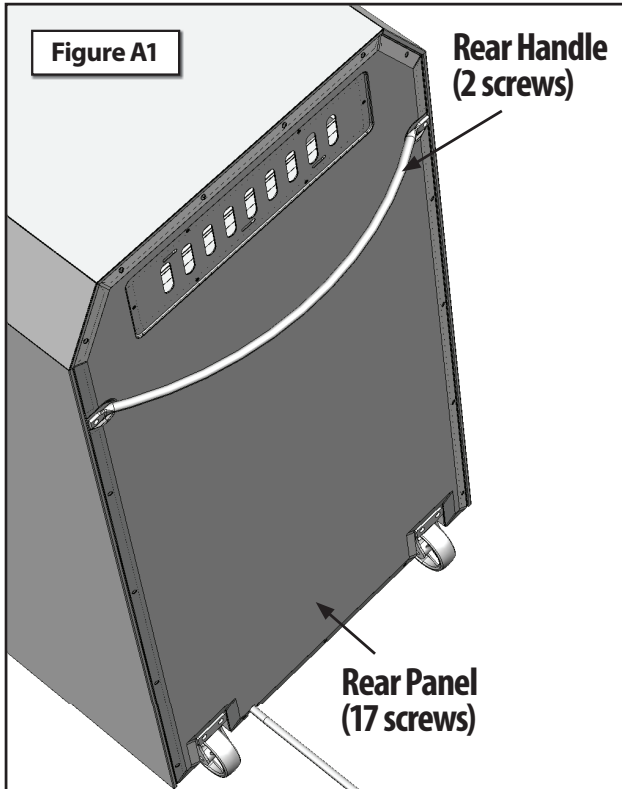
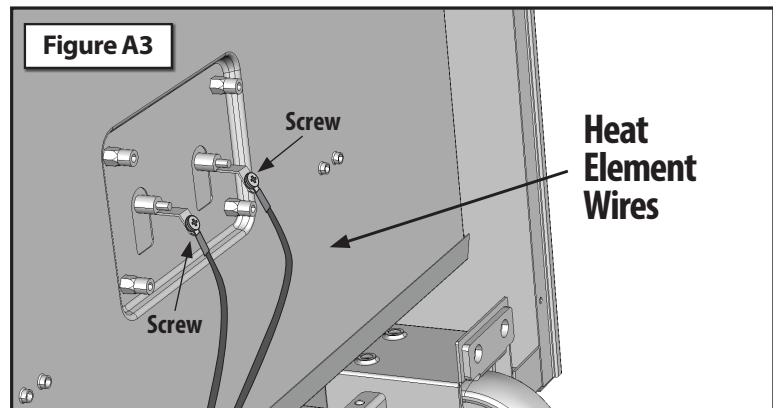
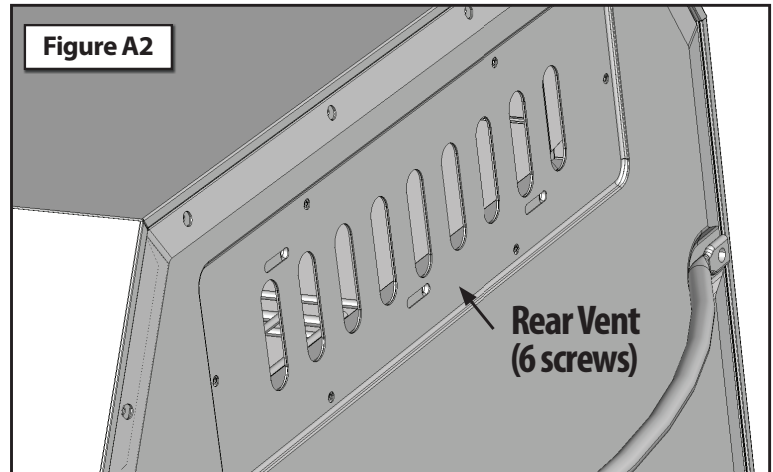

# Part Replacement Guide

## High Temp Limit Safety Switch Access/Replacement

### Removal:

1. Make sure smoker is turned OFF and is unplugged from electrical outlet
2. Remove all cooking grids and water pan from smoker
3. Remove rear handle - (2) screws - (Figure B1)
4. Remove rear vent - (6) screws - (Figure B2)
5. Remove rear panel - (17) screws - (Figure B1)
6. Remove (2) wires that are connected to tabs on High Temp Limit Safety Switch - (Figure B3)
7. Remove (2) bolts and nuts from High Temp Limit Safety Switch bracket - (Figure B3)

**NOTE:** Will need to secure bolts from inside smoker to remove.

### Installation:

8. Position new High Temp Limit Safety Switch on back of smoker where original switch was in place
9. Using (2) bolts and nuts, secure High Temp Limit Safety Switch to inner back panel
10. Attach wires onto tabs of new High Temp Limit Safety Switch
11. Reattach rear panel - (17) screws
12. Reattach rear vent - (6) screws
13. Reattach rear handle - (2) screws
14. Place water pan and cooking grids back into smoker.
15. Plug smoker back into an electrical outlet

**Tools Needed:** Phillips Screwdriver

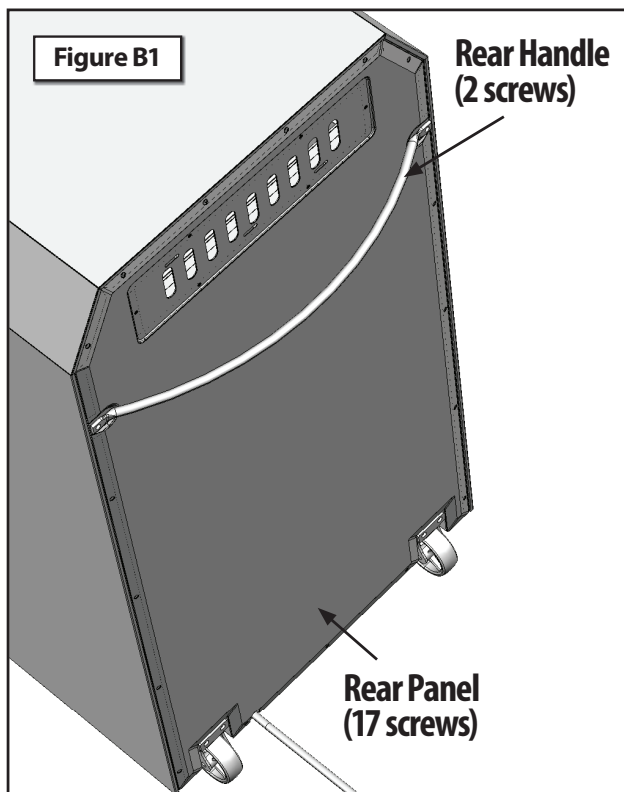
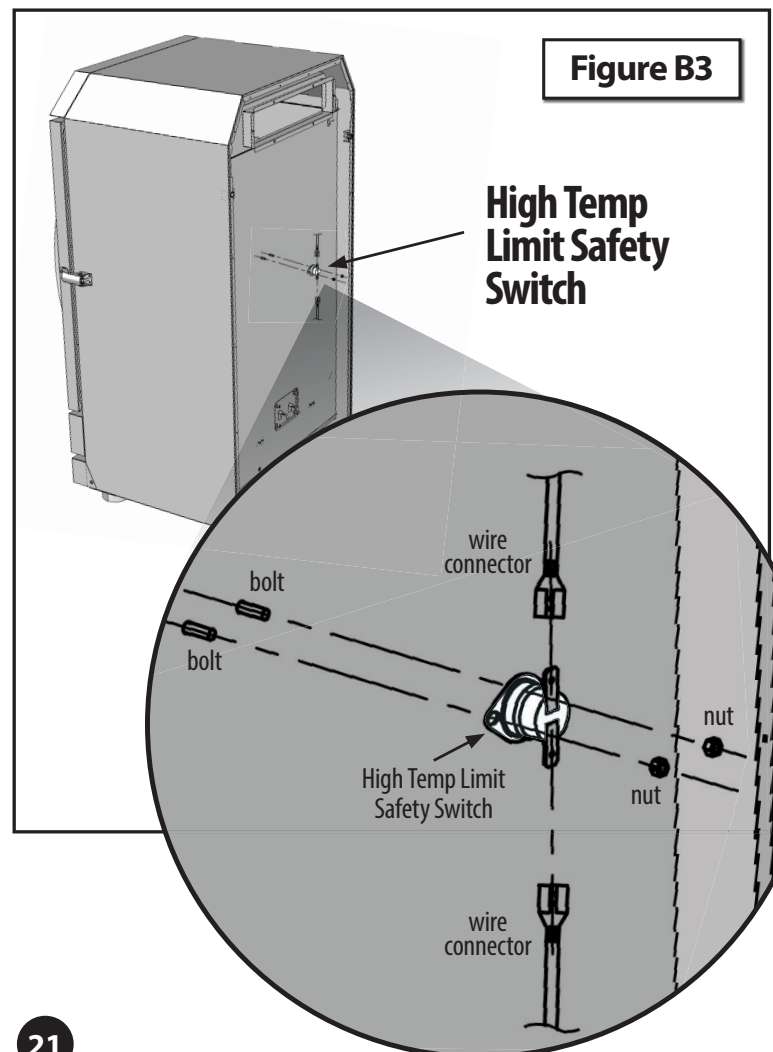
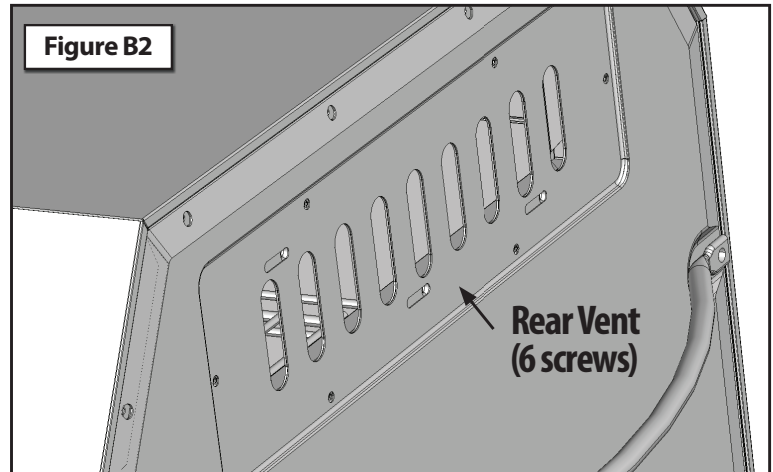

# Part Replacement Guide

## Smoke Element Access/Replacement

### Removal:

1. Make sure your smoker is OFF and is unplugged
2. Remove all cooking grids and water pan from smoker
3. Remove wood chip tray tent, wood chip tray and grease tray
4. Remove (3) screws from smoke element bracket from inside smoker - (Figure C1)
5. Lay the smoker on its side as shown - (Figure C2)
6. Remove bottom panel - (16 screws)
7. Remove wires from Smoke Element - (Figure C3)
8. Remove smoke element from inside smoker

### Installation:

9. Place the new smoke element into smoker and secure with (3) screws previously removed.
10. Push wires back onto the tabs of new smoke element from the back of smoker
11. Reattach bottom panel onto smoker with same 16 screws previously removed
12. Lift smoker back to its upright position
13. Place water pan and cooking grids back into your smoker.
14. Place wood chip tray tent, wood chip tray and grease tray back into smoker
15. Plug smoker back into an electrical outlet

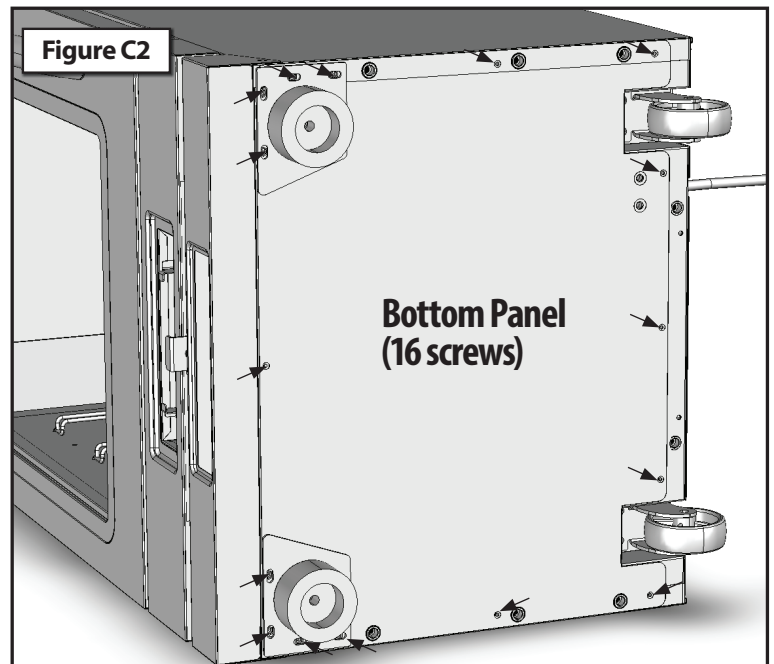
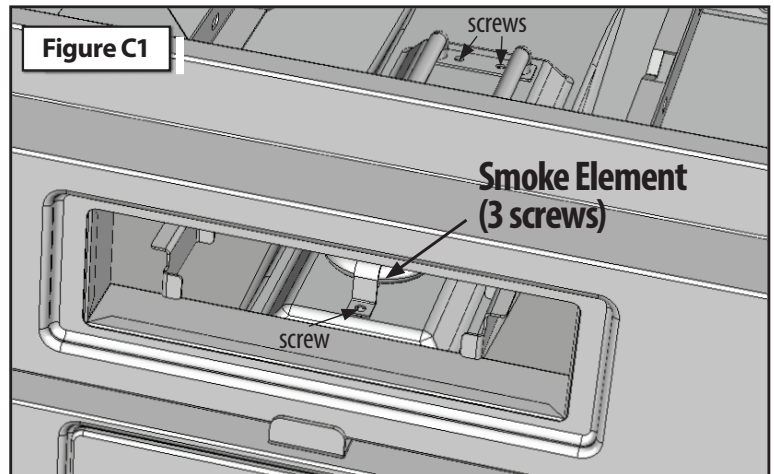

## Power Control Board Access/Replacement

### Removal:

1. Make sure your smoker is OFF and is unplugged
2. Remove all cooking grids and water pan from smoker
3. Remove wood chip tray tent, wood chip tray and grease tray
4. Lay the smoker on its side as shown - (Figure C2)
5. Remove bottom panel - (16 screws)
6. Remove wires from Power Control Board - (Figure C3)
7. Remove Power Control Board - (2 screws) - (Figure C3)

### Installation:

8. Place the new power control board in smoker.
9. Secure new power control board to grease tray rail with same (2) screws previously removed.
10. Connect all wires back onto power control board
11. Assemble bottom panel onto smoker with same 16 screws previously removed
12. Turn smoker back to its upright position
13. Place water pan and cooking grids back into your smoker.
14. Place wood chip tray tent, wood chip tray and grease tray back into smoker
15. Plug smoker back into an electrical outlet

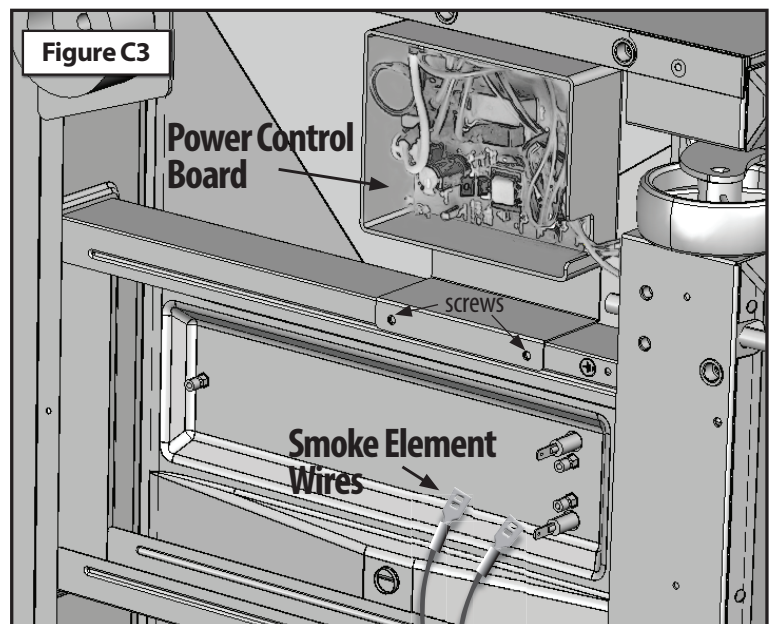

# Part Replacement Guide

## Control Panel/Controller Access/Replacement

### Removal:

1. Make sure your smoker is turned OFF and is unplugged
2. Unlatch and open smoker door.
3. Remove (4) screws from underside of control panel - (Figure D1)
4. Carefully lift control panel up and off of smoker. Be careful not to pull control panel far from smoker as wires are short.
5. Disconnect wires for LED light, Meat Probe, Thermocouple and Power Supply (Note: Make sure to note or label where each connector goes) - (Figure D2)

### Installation:

6. Reconnect wires for LED light, Meat Probe, Thermocouple and Power Supply on new Control Panel and Controller Assembly.
7. Make sure wires are tucked back in control panel for assembly
8. Carefully slide top of control panel down over holding bracket on top face of smoker.
9. Align (4) holes in bottom of control panel with brackets on smoker and reattach with (4) screws - (Figure D1)
10. Close smoker door and latch
11. Plug smoker back into an electrical outlet

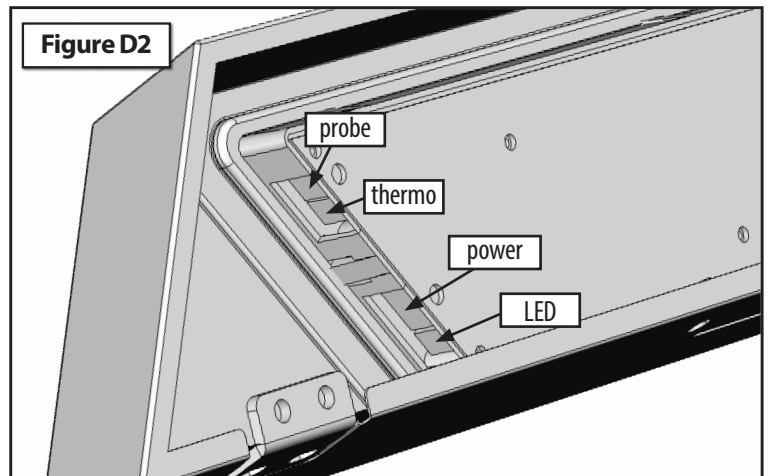
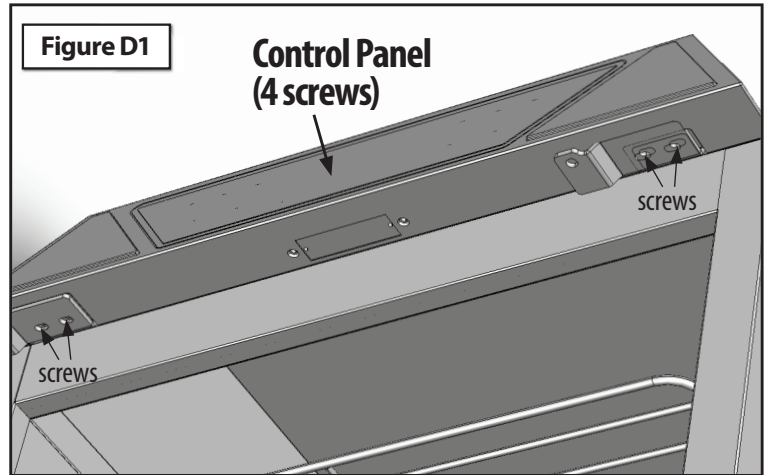

## Meat Probe Access/Replacement

### Removal:

1. Make sure your smoker is turned OFF and is unplugged
2. Unlatch and open smoker door.
3. Remove (4) screws from underside of control panel - (Figure D1)
4. Carefully lift control panel up and off of smoker. Be careful not to pull control panel far from smoker as wires are short.
5. Disconnect wire for Meat Probe (Note: Mark or remember where connector goes) - (Figure D2)
6. Carefully remove two screws holding Meat Probe bracket to smoker panel face and pull Meat Probe thru front face of smoker - (Figure D3)

### Installation:

7. Push Meat Probe thru hole in front face of smoker.
8. Position Meat Probe Plug into hole and attach Meat Probe Brackets with (2) screws. (Make sure there is enough wire to reconnect with the control panel.
9. Reconnect wire for Meat Probe to control panel - (Figure D2)
10. Make sure all wires are tucked in back of control panel for assembly

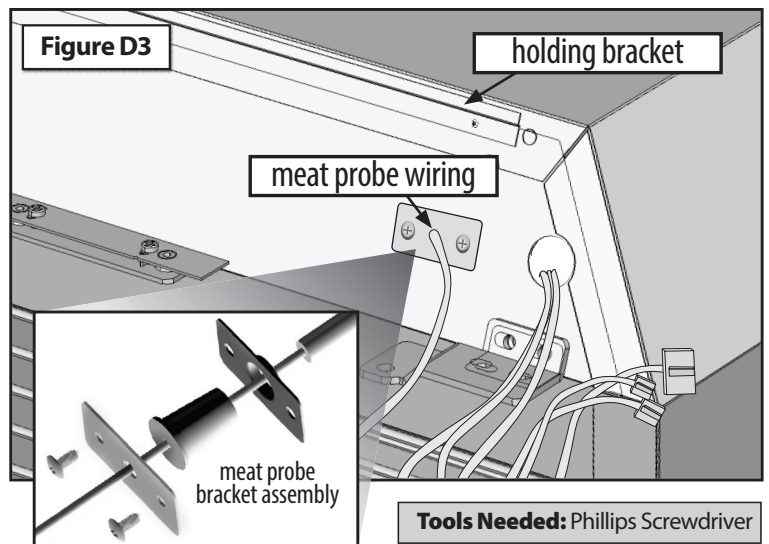

11. Carefully slide top of control panel down over holding bracket on top face of smoker. - (Figure D3)
12. Align (4) holes in bottom of control panel with brackets on smoker and reattach with (4) screws - (Figure D1)
13. Close smoker door and latch
14. Plug smoker back into an electrical outlet



# Smoking Tips

---

## Types of wood to use for smoke:

- Always use a hardwood that has been seasoned for at least 6 months.
- We recommend using Pecan, Hickory, White Oak, Apple, Alder or Mesquite.
- Never use any resin woods like Pine or Cedar.

Note: It is not necessary to soak the wood prior to smoking because hard woods have natural moisture in the wood that will release in the smoker as it heats up. In a gas smoker, soaking the wood chips may prolong the life of the wood chips but it will also take longer to produce smoke so we will leave that decision up to you. Do not soak your wood chips when using your Smoke Hollow electric smoker.

---

## What you need to smoke meats:

### Internal Meat Thermometer

An internal meat thermometer is a must to cook large pieces of meat to make sure it is done internally.

### Internal Temperatures for Select Meats

- Cooked Ham -140 degrees
- Ham, Beef-Med, Ground Beef - 160 degrees
- Veal, Lamb, Pork, Beef-Well done - 170 degrees
- Poultry - 180 degrees

### Good Tongs or Meat Hook

Use a heavy-duty set of tongs to rotate meat in the smoker because in some cases you may be smoking a very large cut of meat. I prefer a meat hook for ease of use and it does not knock any rub or sauce off of the meat.

### Good Oven Mitts

Heavy-duty mitts will assist you in moving hot smoker racks and large pieces of meats and assist in adding water and wood chips.

### Aluminum Foil

When the outside color of your meat product is at your desired color or look to suit your taste, wrap meat product in aluminum foil to keep any more wood resins from turning your meat any darker. Also it will saturate fats from your meat product.

# Smoking Techniques

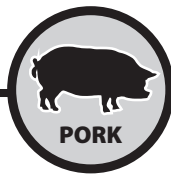

## Smoked Pork Tenderloin

Take outside wrapper off of meat and wash thoroughly in cold water. Place tenderloin on a paper towel to soak up excess water. Rub your favorite pork rub on the loin (we recommend Head Country Pork seasoning). Preheat smokers to 225 degrees and place loin in the center of the smoker. Cook until internal meat temperature reaches 165 degrees. Take out of smoker and let stand on the cutting platter until meat reaches 170 degrees serving temperature. Slice like bread in ¼" pieces and it will melt in your mouth.

## Pork Ribs- Baby Backs or Spare Ribs

Take ribs out of wrapper and drain all liquid off of the ribs and then wash in cold water. Place on cutting board and cut away any excess fat or skin from the bottom of ribs. Turn ribs with bone side up and peel the membrane from the back of the bone until all is gone. Rub your favorite pork rub on both sides of the ribs (we recommend Head Country Pork seasoning). Preheat smoker until it reaches 225 degrees and place rib bone side down in smoker. After one hour, turn the rib over with bone side up and cook for one hour. After 2 1/2 hours, depending on the color of the rib you like, pour a one inch wide strip of your favorite BBQ sauce down the length of the rib and wrap tightly in aluminum foil. Place back in smoker and check every 15 to 20 minutes to see if the rib bones separate by using your finger to pull them apart. If they pull apart with ease your ribs are done. Note: Make sure your internal temperature of your ribs are at 170°F. Take out of smoker and let stand on serving platter until cool enough to eat.



## Smoked Beef Brisket

Select a 6 to 8 lb. packer trimmed brisket that has a little marble to it but not too much. Feel free to trim as much fat as desired. Use your favorite beef rub (we recommend using Head Country All-Purpose rub) and rub it on liberally. Heat the smoker to 225 degrees and place the brisket in the smoker for 3 hours. Place brisket in an aluminum foil pan and pour approximately 8oz. of Allegro over the brisket. Cover the pan tightly with aluminum foil and continue cooking until internal meat temperature reaches 165 to 170 degrees. Take pan out of the smoker and let brisket stand. Remove brisket from pan and cut ¼" slices against the grain. Use juice from pan to pour over sliced meat or for dipping.

## Prime Rib

Select a 6 to 8 lb prime rib (we like the bone on). Rub the prime rib with your favorite beef rub (we recommend using Head Country All-Purpose rub). Pre-heat the smoker to 225 degrees and place the prime rib in the smoker. After 3 hours, place the prime rib in aluminum foil pan and cover with aluminum foil. When internal meat temperature reaches 145 degrees take out of smoker and let stand until your desired doneness is reached. Medium rare is 155 to 160 degrees. While standing, the temperature of the meat will rise internally up to 10 degrees. Slice prime rib to desired thickness and serve with juice from the pan in which it was cooked.

# Smoking Techniques



## Smoked Halibut

Select a nice fresh  $\frac{3}{4}$ " thick filet. Wash filet thoroughly in cold water and lay on paper towel until water is not visible. Melt a whole stick of butter in the microwave and sprinkle a liberal amount of Dill weed in the melted butter. Lay filets on aluminum foil and fold a lip around edges to contain the butter. With a basting brush, brush melted butter and dill weed mixture on both sides of the fish filet. Preheat smoker to 225 degrees and place fish in the smoker. Check the filets every 15 minutes for visible moist look on filets. Brush with butter and dill weed mix when needed. Fish should start to flake in about 45 minutes. When fish flakes very easy take out of smoker and serve.



## Smoked Chicken

Chicken breasts and thighs are my favorite. Take chicken parts out of package and wash thoroughly and place on paper towel to dry. Sprinkle Head Country Original rub on both sides of chicken parts. Preheat smoker to 225 degrees and place chicken parts in smoker. After  $\frac{1}{2}$  hour turn chicken over. With your internal temperature gauge, check internal temperature by pushing temperature probe into the meat nearest the bone. When temperature reaches 180 degrees chicken is done. You may brush your favorite BBQ sauce on the chicken during the last 15 minutes of your cooking process to spice it up.

## Smoked Turkey

Select a 12 to 15 lb. turkey for best results in a smoker. Take the turkey out of the package and remove all internal parts and packaging. Wash turkey thoroughly and place it on paper towel to dry. Rub olive oil inside and out on the turkey and apply Head Country Original Rub inside body cavity and on the outside skin. Preheat smoker to 225 degrees and place turkey in smoker. You may baste with butter for more moisture, if you like. When turkey skin reaches your desired color, remove turkey from smoker, place in aluminum foil pan and cover with aluminum foil tightly. Place covered pan in smoker and continue cooking at 225 degrees. Check internal meat temperature, where the thigh meets the side of the turkey, every half hour for doneness. Turkey should take around 45 minutes per lb to reach 180 degrees serving temperature.

# Cold Smoking Recipes

## Smoked Cheddar Cheese

### Ingredients

Brick of Cheddar Cheese (Old or Aged cheddar is preferred - substitute Gouda or Fontina for a change of flavor.)

### Preparation

Place cheese on racks and load into your Smoke-Tronix smoker by Smoke Hollow®.

### Smoking Method

1. Fill the wood chip tray with your favorite wood chips.
2. Open the back and lower vents completely.
3. Push the fast smoke button and set your time, temp and probe if desired.
4. It is best to keep the internal temp lower than 100° F when smoking cheese.
5. If the internal temp is too hot, you may need to place a pan of ice under your cheese rack to help reduce the internal temp or open the door slightly.
6. Smoke for approximately 40 to 60 minutes.

## Cold Smoked Salmon Serves 8-10 as an appetizer

### Ingredients

- 2 to 3 pounds fresh salmon fillet (preferably from the head end)
- 1 1/2 cups coarse sea salt or kosher salt
- 1 1/2 cups brown sugar

### Optional Garnishes

- Diced red onion, Sliced lemons, Chopped fresh dill or Sour cream

### Preparation

1. Run your fingers over the flesh side of the salmon fillets, feeling for the sharp ends of pin bones. Pull out any you find with fish tweezers or needle nose pliers.
2. Make the cure: Combine the salt and brown sugar in a mixing bowl and mix with your fingers. Spread 1/3 of the cure over the bottom of a glass baking dish just large enough to hold the fish. Lay the salmon fillets on top of the cure. (The cure should extend 1/2 inch beyond the edges of the fish on each side.) Spread the remaining cure on top so it covers the fish completely.
3. Cover the dish with plastic wrap and cure the fish in the coolest part of your refrigerator for 24 to 48 hours.
4. Gently rinse the cure off the salmon under cold running water. Place the salmon in a large bowl with cold water to cover by 3 inches. Soak for 30 minutes, then drain well in a colander.
5. Blot the salmon dry on both sides with paper towels. Arrange it skin side down on a wire rack over a sheet pan. Let the salmon dry, uncovered, in the refrigerator until it feels tacky, about 4 hours.

### Smoking Method

1. Fill the wood chip tray with your preferred flavor of wood chips. Beechwood or Alder are good choices for salmon.
2. Open the back and lower vents completely.
3. Push the fast smoke button and set your time, temp and probe if desired.
4. If the internal temp goes above 100°, you may need to place a pan of ice under your salmon rack to help reduce the internal temp or open the door slightly.
5. Cold smoke the salmon until the exterior is bronzed with smoke and the salmon feels semi-firm and leathery, 12 hours or more. How will you know it's ready? Cut a slice from next to the skin at the fat end.
6. Wrap salmon in uncoated butcher paper and let rest in the refrigerator for at least 4 hours before serving or overnight.
7. Using a long, slender and sharp knife held sharply on the diagonal to the fish, cut the salmon into paper-thin slices.

# Limited Warranty

---

This Smoke Hollow® smoker is guaranteed against broken or damaged parts at time of purchase. All parts carry a 1-year limited warranty. Paint is guaranteed to be free of defects for 90 days except for rust, which may appear after repeated use.



This warranty does not cover damage or issues related to neglect, abuse, or modifications to the product. Repair labor is not covered.

All parts that meet the warranty requirements will be shipped at no-charge via the discretion of the Customer Service Department (ground shipments, US Mail, or Parcel Post Only). Any special handling charges (i.e. Second Day, Overnight, etc.) will be the responsibility of the consumer.

All warranty claims apply only to the original purchaser and require a proof of purchase verifying purchase date. Do not return parts to our address without first obtaining a return authorization number from our customer service.

This service is available by calling 866-475-5180, 8:30am to 4:30pm, Central Time, Monday through Friday, or write to Outdoor Leisure Products, Inc., 5400 Doniphan Drive, Neosho, MO 64850.

This warranty may give you specific legal rights that vary by state.

---

**Outdoor Leisure Products, Inc**  
5400 Doniphan Drive  
Neosho, MO 64850  
[www.olp-inc.com](http://www.olp-inc.com)

© 2015 Outdoor Leisure Products, Inc. No part of this work may be reproduced, modified, distributed, or otherwise used without prior written permission. Smoke Hollow and Smoke-Tronix are trademarks of Outdoor Leisure Products, Inc. The Bluetooth® word mark and logos are registered trademarks owned by Bluetooth SIG, Inc. and any use of such marks by Outdoor Leisure Products, Inc. is under license. Apple, the Apple logo, iPhone, iPad, and iPod touch are trademarks of Apple Inc., registered in the U.S. and other countries. App Store is a service mark of Apple Inc. Google Play is a trademark of Google Inc.

01062017