

This Owner's Manual is provided and hosted by [Appliance Factory Parts](#).

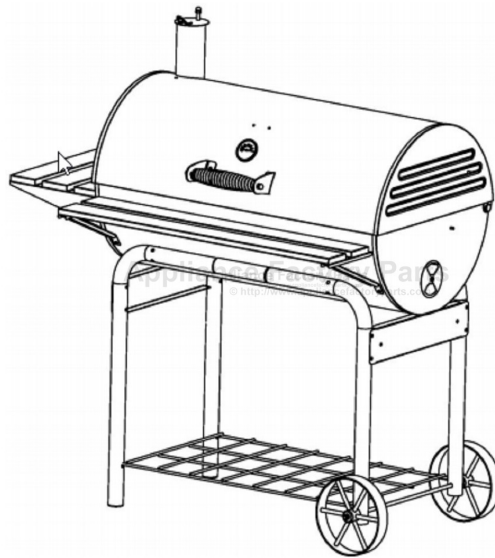

River Grille CG2053904-RG Owner's Manual

[Shop genuine replacement parts for River Grille
CG2053904-RG](#)



[Find Your River Grille Grill Parts - Select From 11 Models](#)

----- Manual continues below -----



Stampede 37.5 Inch Charcoal Grill

Owner's Manual

Assembly and Operating Instructions

Model # CG2053904-RG

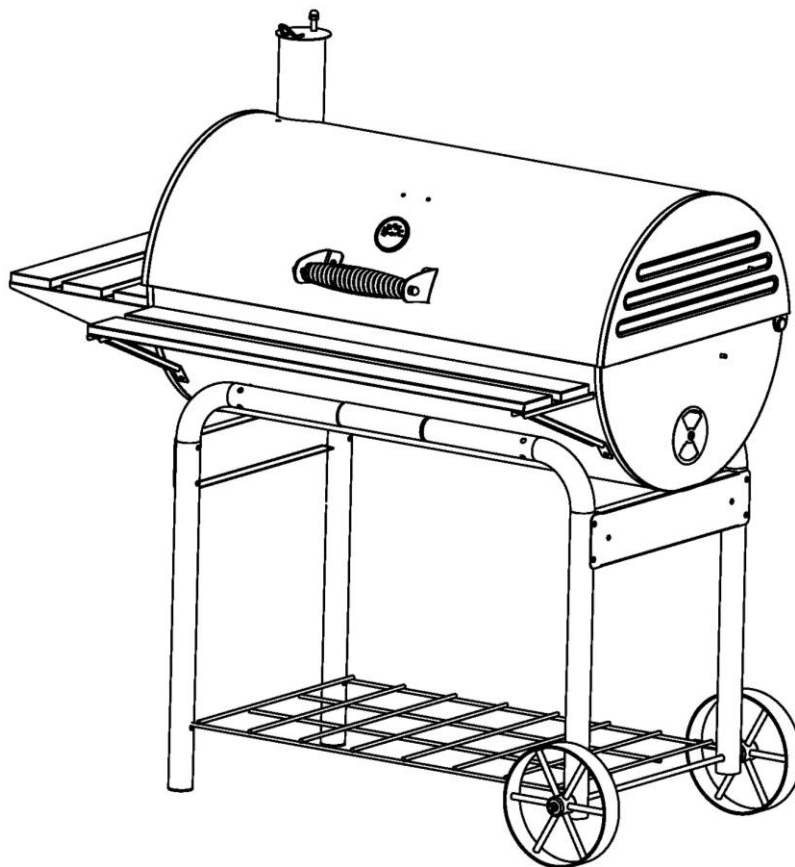

Tools required for assembly: (Not Included) Pliers, Philips & Flathead Screwdrivers, Adjustable Wrench.

Keep this manual for future reference.

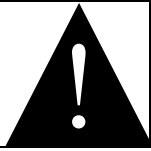

WARNING



- Only use this grill on a hard, level, non-combustible, stable surface (concrete, ground, etc.) capable of supporting the weight of the grill. Never use on wooden or other surfaces that could burn.
- When grill is in use, keep clearance of 36" between the hot grill and any combustible materials, such as bushes, trees, wooden decks, wooden fences, buildings, etc. Do not place hot grill under roof overhang or in any other enclosed area.
- The maximum weight of charcoal to be used is 3.5 pounds (1.59kg). Too much charcoal may cause the surface coating peel off.
- **FOR OUTDOOR USE ONLY. DO NOT operate grill indoors or in an enclosed area** because of carbon monoxide poisoning that can lead to personal injury or death.
- For household use only. Do not use this grill for other than its intended purpose.
- We recommend the use of a Charcoal chimney starter to avoid the dangers associated with charcoal lighting fluid. If you choose to use charcoal lighting fluid, only use lighting fluid approved for lighting charcoal. Carefully read manufacturer's warnings and instructions on the charcoal lighting fluid and charcoal prior to the use of their product. Store charcoal lighting fluid safely away from grill.
- When using charcoal lighting fluid, allow charcoal to burn with grill lid and doors open until covered with a light ash (approximately 20minutes). This will allow charcoal lighting fluid to burn off. Failure to do this could trap fumes from charcoal lighting fluid in grill and may result in a flash fire or explosion when lid is opened.
- Do not use gasoline, kerosene or alcohol for lighting charcoal. Use of any of these or similar products could cause an explosion possibly leading to severe bodily injury.
- Never add charcoal lighting fluid to hot or even warm coals as flashback may occur causing severe burns.
- Place grill in an area where children and pets cannot come into contact with unit. Close supervision is necessary when grill is in use.
- Do not leave grill unattended when in use.
- When adding charcoal and / or wood, use extreme caution and follow instructions in "Adding Charcoal / Wood During Cooking" section of this manual.
- Do not store or use grill near gasoline or other flammable liquids, gases or where flammable vapors may be present.
- Do not store lighter fluid or other flammable liquids or materials under the grill.
- Use caution when adjusting charcoal grate height, use oven mitt. Handle will be hot when in use.
- Never raise or lower charcoal grate when water smoking as hot water may splash on to coals creating a burst of hot steam and coals.

Grill is hot when in use. To avoid burns:

- DO NOT attempt to move the grill.
- Wear protective gloves or oven mitts.
- DO NOT touch any hot grill surfaces.
- DO NOT wear loose clothing or allow hair to come in contact with grill.

CALIFORNIA PROPOSITION 65

Fuels used in wood or charcoal burning appliances, and the products of combustion of such fuels, can expose you to chemicals including carbon black, which is known to the State of California to cause cancer, and carbon monoxide, which is known to the State of California to cause birth defects or other reproductive harm. For more information go to: www.P65Warnings.ca.gov

Wash your hands after handling this product.



WARNING

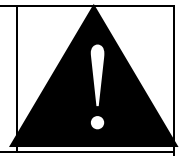

- When grilling, grease from meat may drip into the charcoal and cause a grease fire. If this should happen close lid to suffocate the flame. Do not use water to extinguish grease fires.
- Use caution when opening the lid, keep hands, face and body a safe distance away. Flash flare ups may occur when air comes into contact with fire or hot coals.
- Never place more than 5 pounds (2.3 kg) on front and side tables.
- Do not allow charcoal and/or wood to rest on the walls of grill. Doing so will greatly reduce the life of the metal and finish of your grill.
- Use caution during assembly and while operating your grill to avoid scrapes or cuts from sharp edges of metal parts. Use caution when reaching into or under grill.
- When opening lid, be sure lid is fully opened and secure to prevent lid from closing unexpectedly.
- In windy weather, place grill in an outdoor area that is protected from the wind.
- Close lid to suffocate flame.
- Never leave coals and ashes in grill unattended, before grill can be left unattended, remaining coals and ashes must be removed from grill. Use caution to protect yourself and property, carefully place remaining coals and ashes in a non-combustible metal container and saturate completely with water, allow coals and water to remain in metal container 24 hours prior to disposing.
- Extinguished coals and ashes should be placed a safe distance from all structure and combustible materials.
- With a garden hose completely wet the surface beneath and around grill to extinguish any ashes, coals or embers which may have fallen during the cooking or cleaning process.
- After each use, clean the grill thoroughly and apply a light coat of vegetable oil to prevent rusting. Cover the grill to protect it from excessive rusting.
- Use caution when lifting or moving grill to prevent strains and back injuries.
- We advise that a fire extinguisher be on hand. Refer to your local authority to determine proper size and type of fire extinguisher.
- Store the grill out of reach of children and in a dry location when not in use.
- Do not attempt to service grill other than normal maintenance as explained in "After-Use Safety" and "Proper Care & Maintenance" sections of this manual.
- Properly dispose of all packaging material.

Use caution and common sense when operating your grill.

Failure to adhere to safety warning and guidelines in this manual could result in bodily injury or property damage.

Save this manual for future reference.

ASSEMBLY INSTRUCTIONS

THANK YOU FOR PURCHASING THIS STAMPEDE 37.5 INCH GRILL

Read all safety warnings & assembly instructions carefully before assembling or operating your grill.

For missing parts, please call customer service at customerservice@rankam.com or

At 888-837-1380(U.S. only),

Mon to Fri, 8:00 a.m. –5:00 p.m. Pacific Standard Time.

(Proof of purchase will be required.)

Inspect contents of the box to ensure all parts are included and undamaged.

We recommend two people for assembly of this grill.





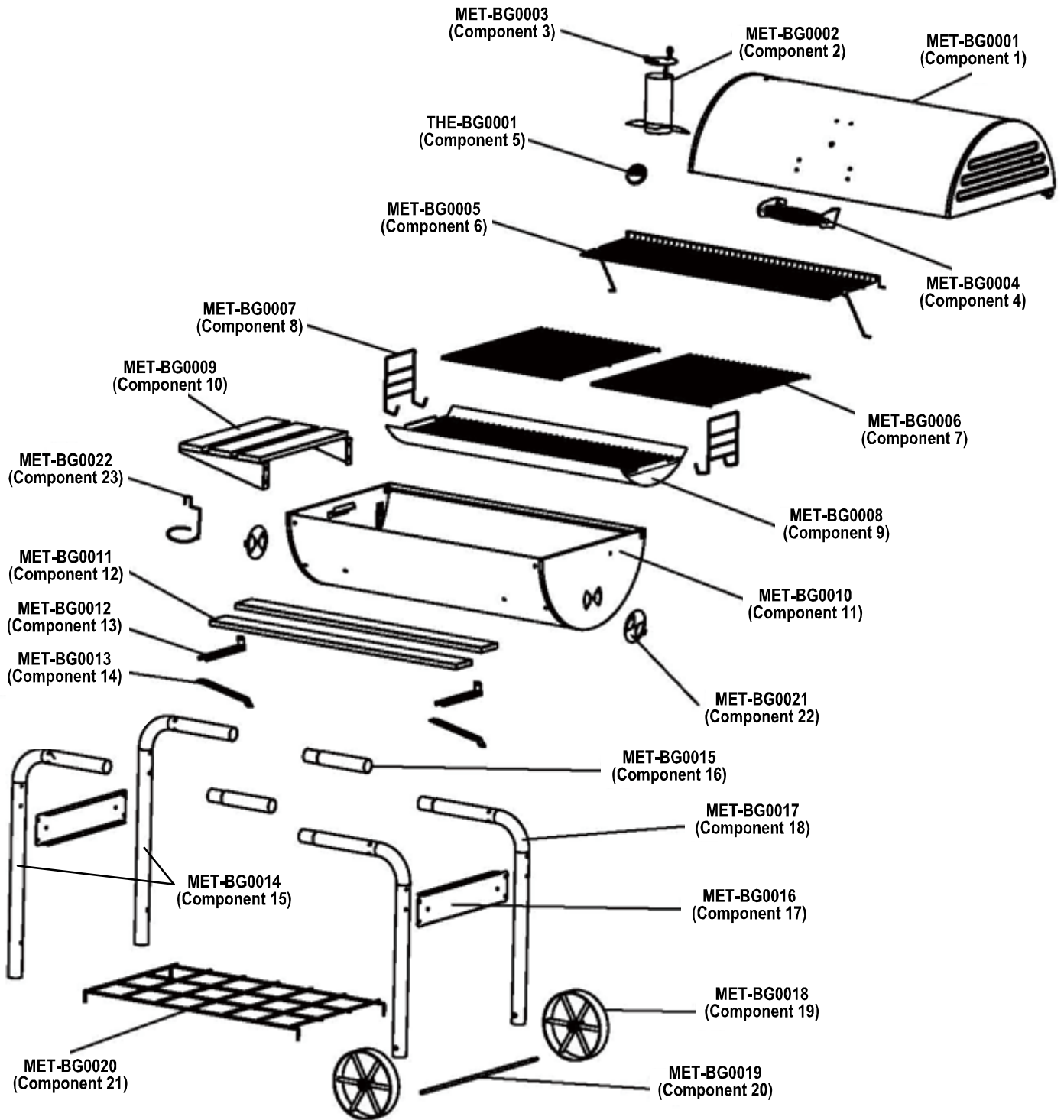

The following tools are required for assembly and are not included:

- Pliers
- Philips & Flathead Screwdrivers
- Adjustable Wrench

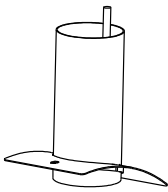
Product Diagram

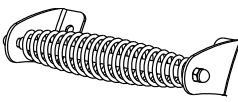
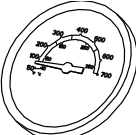

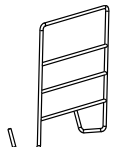
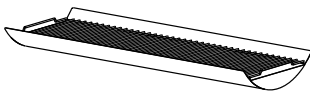
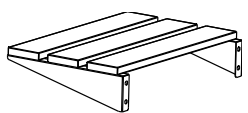
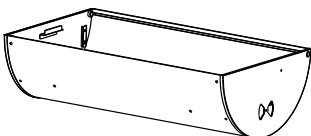
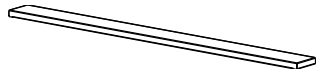
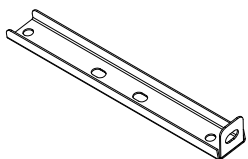
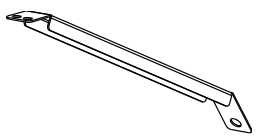
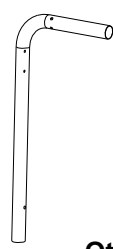
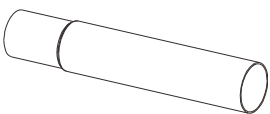
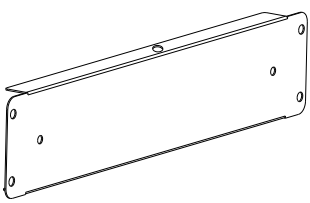
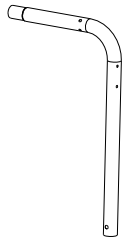
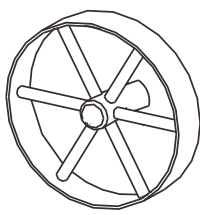
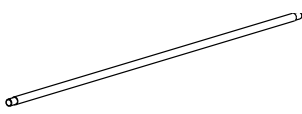
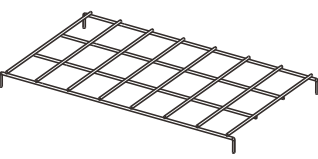

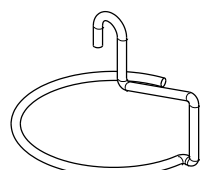
Component List

<p>1. Lid Part number: MET-BG0001</p>  <p style="text-align: right;">Qty. 1pc</p>	<p>2. Smoke Stack Part number: MET-BG0002</p>  <p style="text-align: right;">Qty. 1pc</p>	<p>3. Damper Part number: MET-BG0003</p>  <p style="text-align: right;">Qty. 1pc</p>	<p>4. Lid Handle Part number: MET-BG0004</p>  <p style="text-align: right;">Qty. 1pc</p>
<p>5. Temperature Gauge Part number: THE-BG0001</p>  <p style="text-align: right;">Qty. 1pc</p>	<p>6. Warming Rack Part number: MET-BG0005</p>  <p style="text-align: right;">Qty.1pc</p>	<p>7. Cooking Grid Part number: MET-BG0006</p>  <p style="text-align: right;">Qty. 2pcs</p>	<p>8. Charcoal tray hanger Part number: MET-BG0007</p>  <p style="text-align: right;">Qty. 2pcs</p>
<p>9. Charcoal tray Part number: MET-BG0008</p>  <p style="text-align: right;">Qty. 1pc</p>	<p>10. Side Shelf Part number: MET-BG0009</p>  <p style="text-align: right;">Qty. 1pc</p>	<p>11. Fire Bowl Part number: MET-BG0010</p>  <p style="text-align: right;">Qty. 1pc</p>	<p>12. Front Shelf Slat Part number: MET-BG0011</p>  <p style="text-align: right;">Qty. 2pcs</p>
<p>13. Front Shelf Bracket Part number: MET-BG0012</p>  <p style="text-align: right;">Qty. 2pcs</p>	<p>14. Front Shelf Support Part number: MET-BG0013</p>  <p style="text-align: right;">Qty.2pcs</p>	<p>15. Left Leg Part number: MET-BG0014</p>  <p style="text-align: right;">Qty. 2pcs</p>	<p>16. Legs Connector Part number: MET-BG0015</p>  <p style="text-align: right;">Qty. 2pcs</p>
<p>17. Legs holder Part number: MET-BG0016</p>  <p style="text-align: right;">Qty. 2pcs</p>	<p>18. Right Leg Part number: MET-BG0017</p>  <p style="text-align: right;">Qty.2pcs</p>	<p>19. Wheel Part number: MET-BG0018</p>  <p style="text-align: right;">Qty.2pcs</p>	<p>20. Axle Part number: MET-BG0019</p>  <p style="text-align: right;">Qty. 1pc</p>
<p>21. Bottom Rack Part number: MET-BG0020</p>  <p style="text-align: right;">Qty. 1pc</p>	<p>22. Air Vent Part number: MET-BG0021</p>  <p style="text-align: right;">Qty. 2pcs</p>	<p>23. Grease cup holder Part number: MET-BG0022</p>  <p style="text-align: right;">Qty. 1pc</p>	

STOP!DO NOT RETURN TO RETAILER

For assembly assistance, missing or damaged parts, **please contact customer service at, customerservice@rankam.com or 888-837-1380 (U.S. only)** Mon to Fri, 8:00 a.m. –5:00 p.m. Pacific Standard Time.

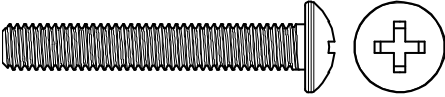
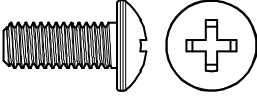
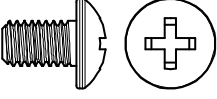
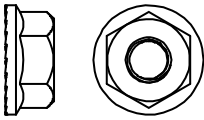
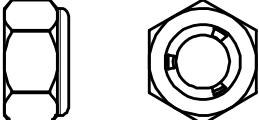
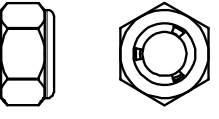
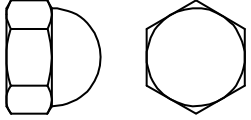
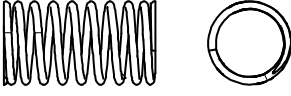
Hardware List

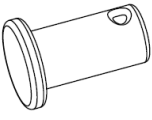
A		Bolt(M6X50)	12pcs
B		Bolt(M6X20)	4 pcs
C		Bolt(M6X12)	22pcs
D		Flange Nut(M6)	26pcs
E		Lock Nut(M8)	2 pcs
F		Lock Nut(M6)	2 pcs
G		Cap Nut(M8) (2 pcs pre-assembled)	3 pc
H		Spring	1 pc
J		Cotter Pin	4 pcs
K		Hinge Pin	2 pcs

Assembly Procedures

Symbol: The following symbols will be shown in each procedure for indication of tightening the bolt and nut if necessary.

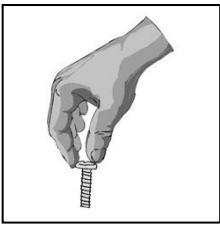

Hand Tighten only at this time

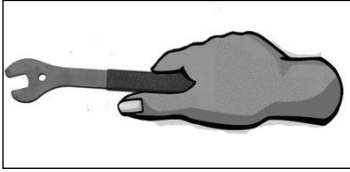

Tighten with tools at this time

Some steps may require the assistance of a friend.

Step 1.Assembly of left legs (15) with legs holder (17)

Hardware required: Bolt A x 4 pcs, Flange nut D x 4 pcs

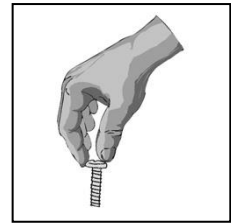
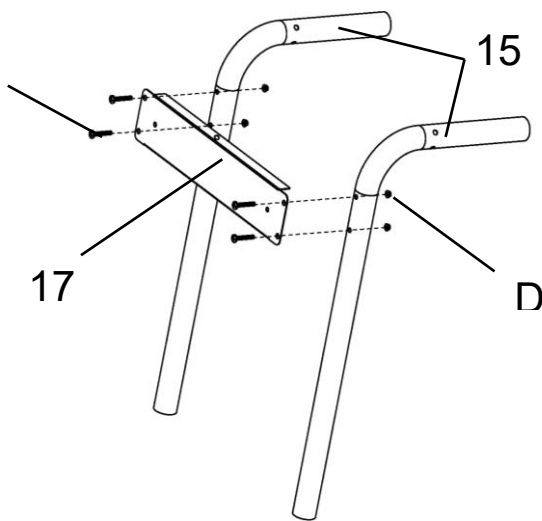

Step 2.Assembly of right legs (18) with legs holder (17)

Hardware required: Bolt A x 4 pcs, Flange nut D x 4 pcs

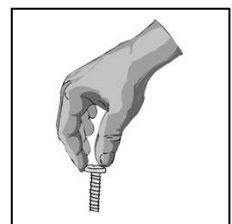
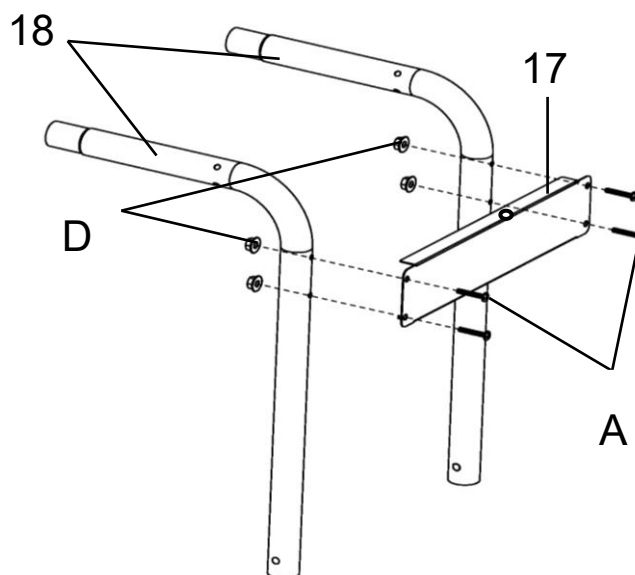

Step 3. Assemble the bottom rack (21) to left and right legs assembly and legs connector (16) to form a cart frame.

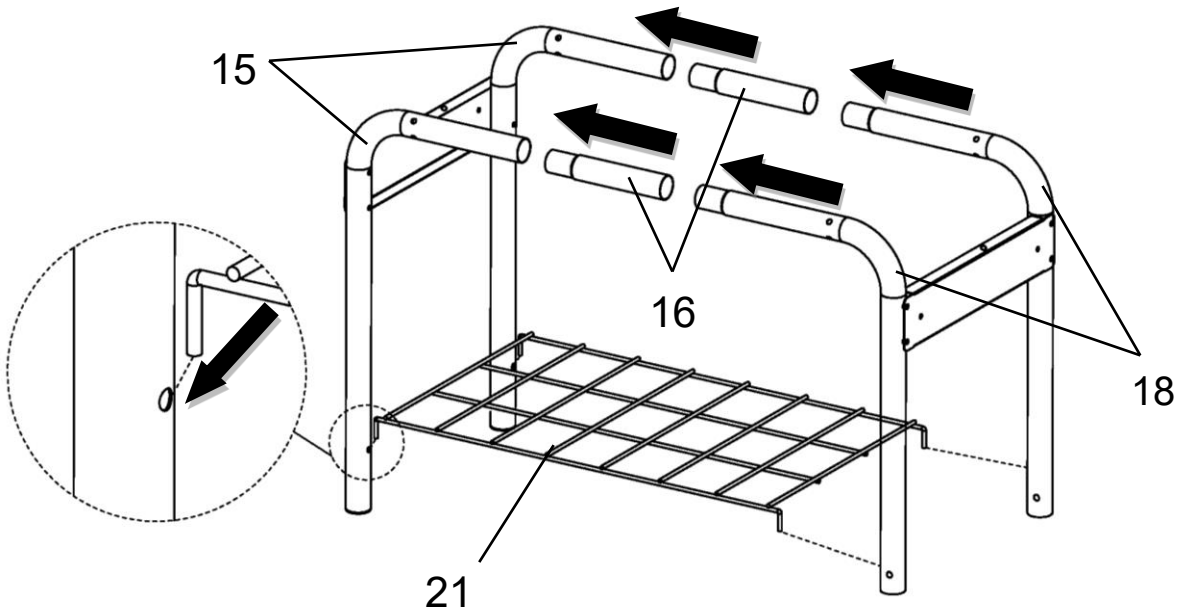

Step 4. Assembly of wheels (19) and axle (20) to cart frame to form a grill cart.
Hardware required: Lock nut E x 2 pcs

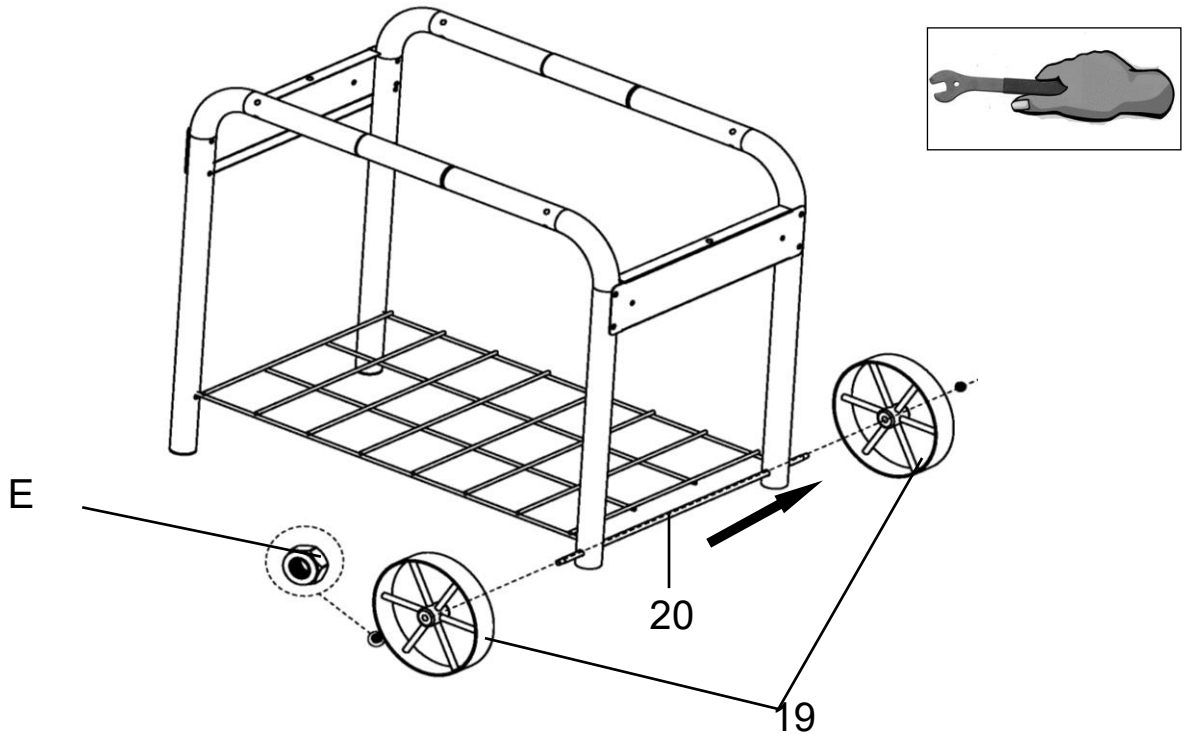

Step5. Assembly fire bowl (11) to grill cart

Hardware required: Bolt A x 4pcs, flange nut D x 4 pcs, bolt C x 2pcs

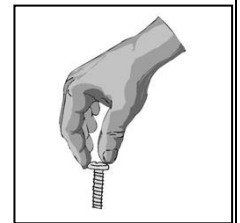
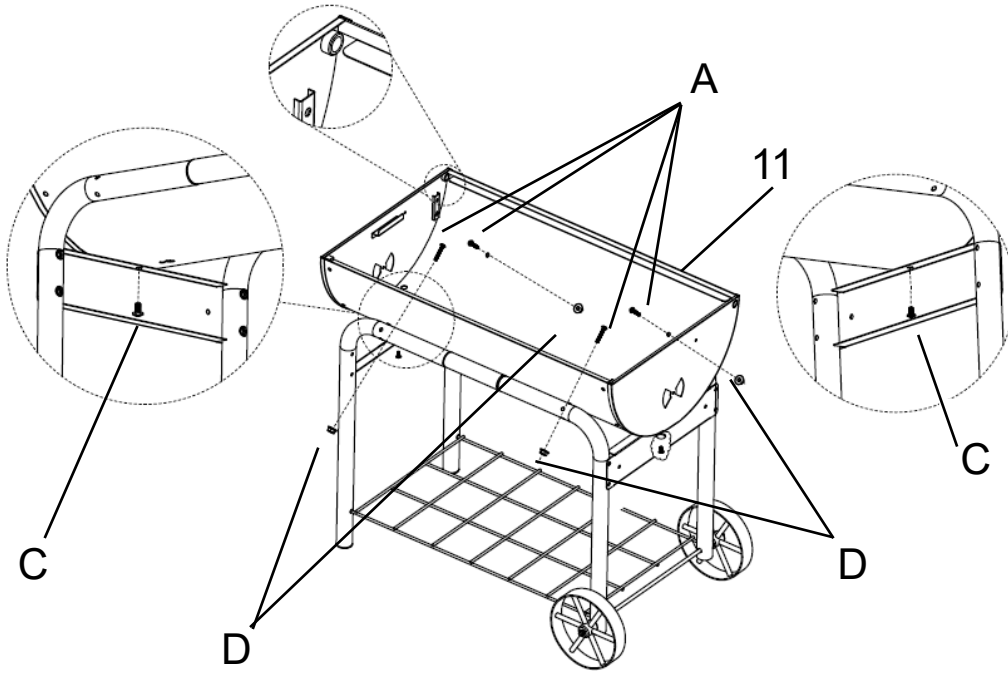

Step6. Tighten the bolts and nuts in steps 1, 2 and 5.

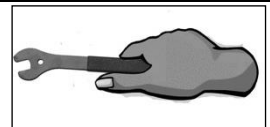

Step7. Assembly air vent (22) to fire bowl. Adjust to suitable tightness for turning.

Hardware required: Bolt C x 2 pcs, lock nut F x 2 pcs

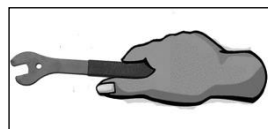
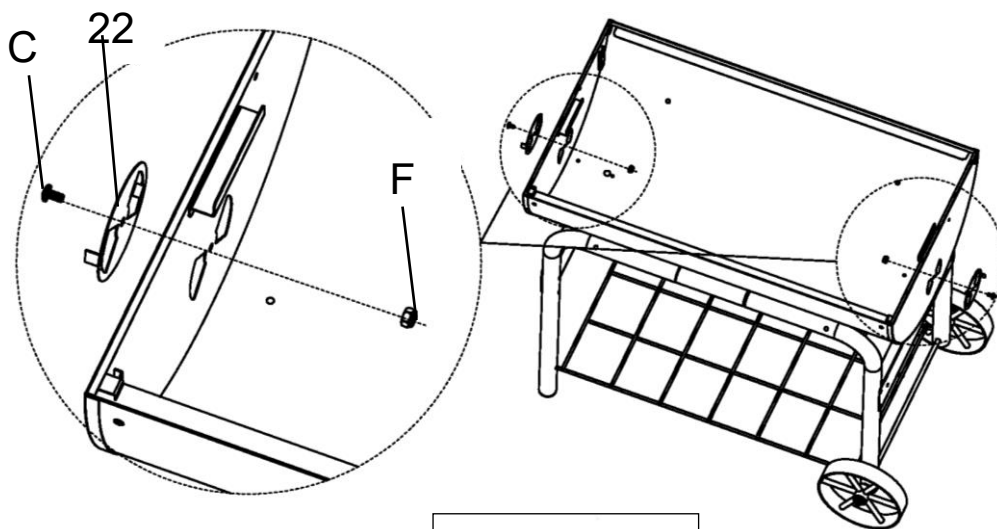

Step 8. Assembly side shelf 10 to fire bowl (11).

Hardware required: Bolt B x 4pcs, flange nut D x 4 pcs

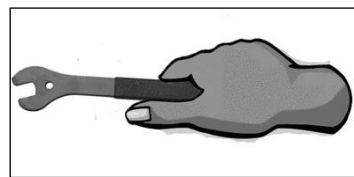
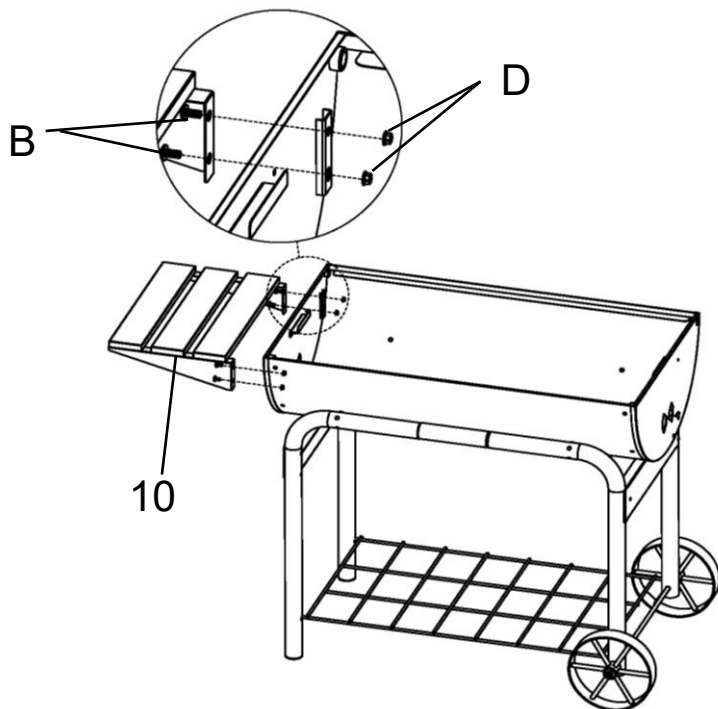

Step 9. Assembly front table slats (12) with front table bracket (13) to form front shelf assembly.

Hardware required: Bolt C x 6 pcs

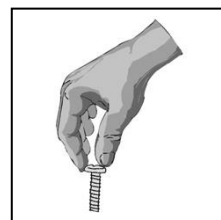
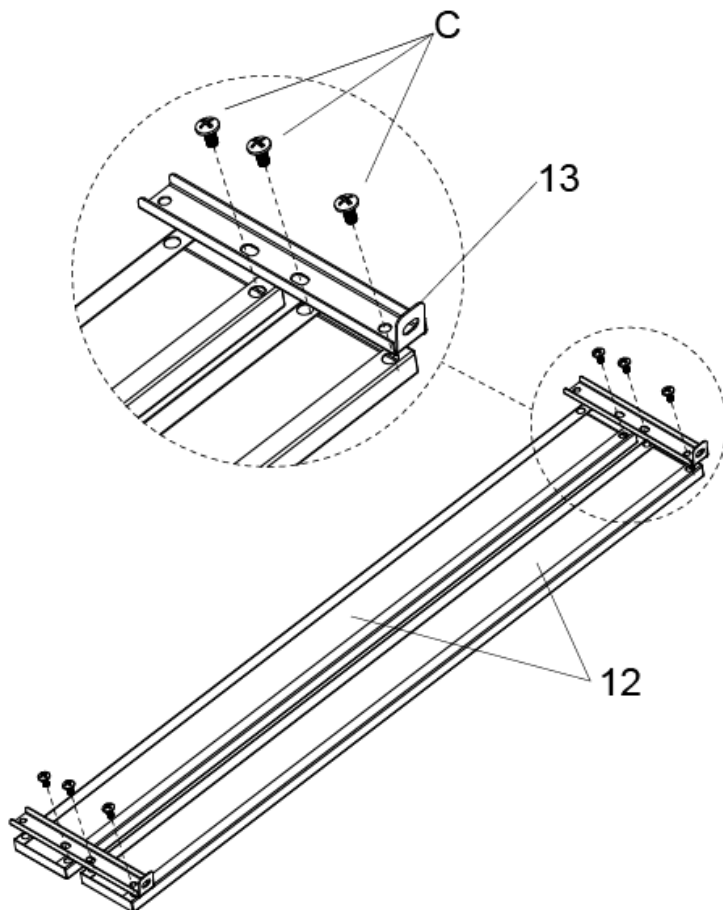

Step 10. Assembly front shelf assembly to fire bowl(11)

Hardware required: Bolt C x 2 pcs, flange nut D x 2 pcs

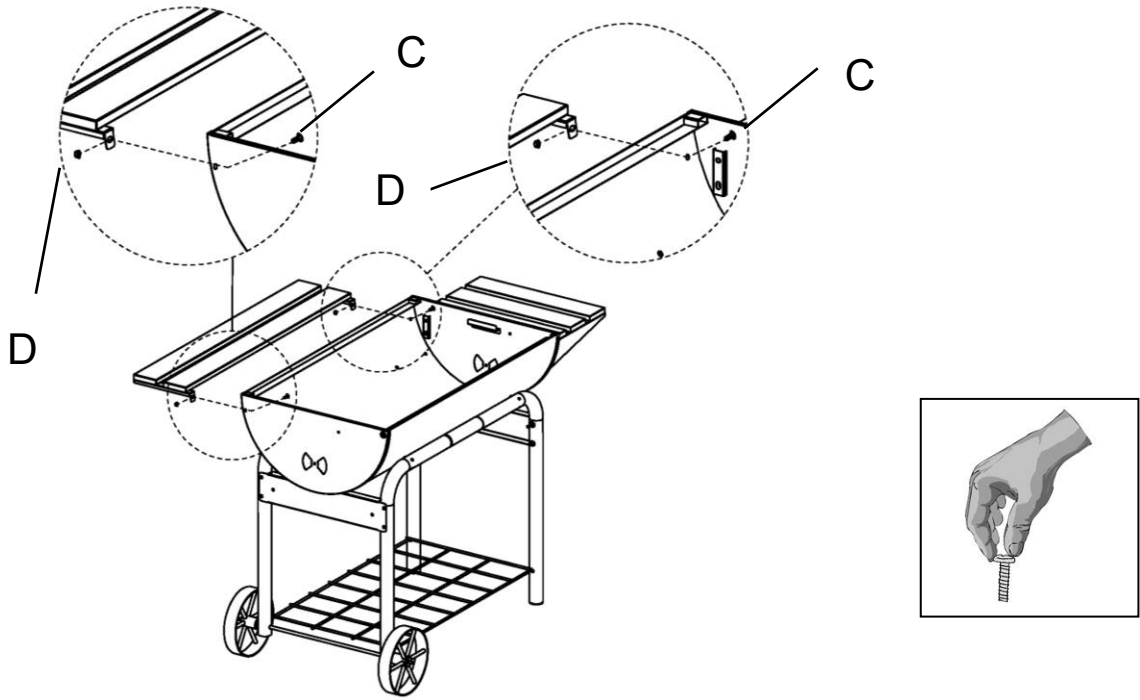

Step 11. Assembly front table support (14) to front table assembly and fire bowl

Hardware required: Bolt C x 4 pcs, flange nut D x 2 pc

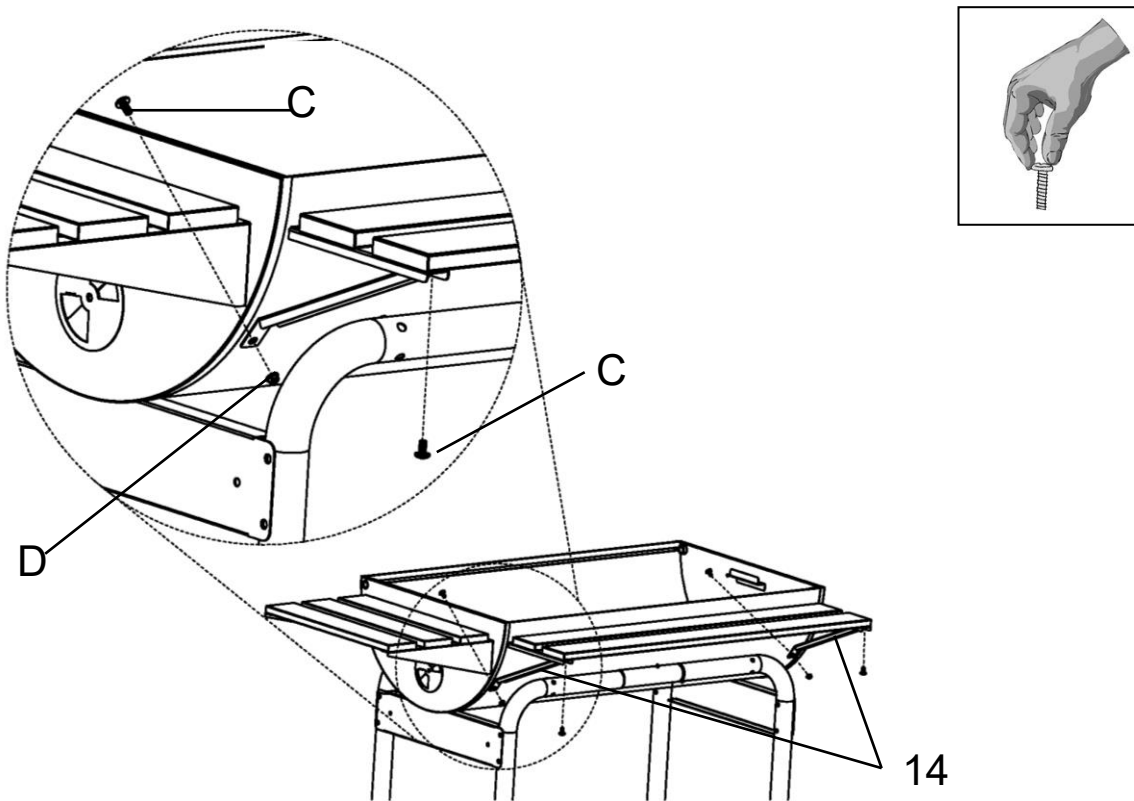

Step 12. Tighten the bolts and nuts in steps 9, 10 and 11.

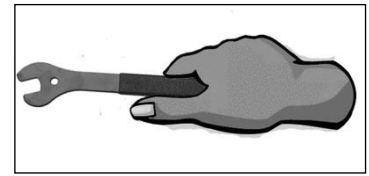

Step 13. Assembly the temperature gauge (5) to lid (1). Then assembly smoke stack (2) to the lid (1) and finally assembly the damper (3)..

Hardware required: Bolt C x 2 pcs, Flange nut D x 2 pcs, Cap nut G and spring H x 1 pc each.

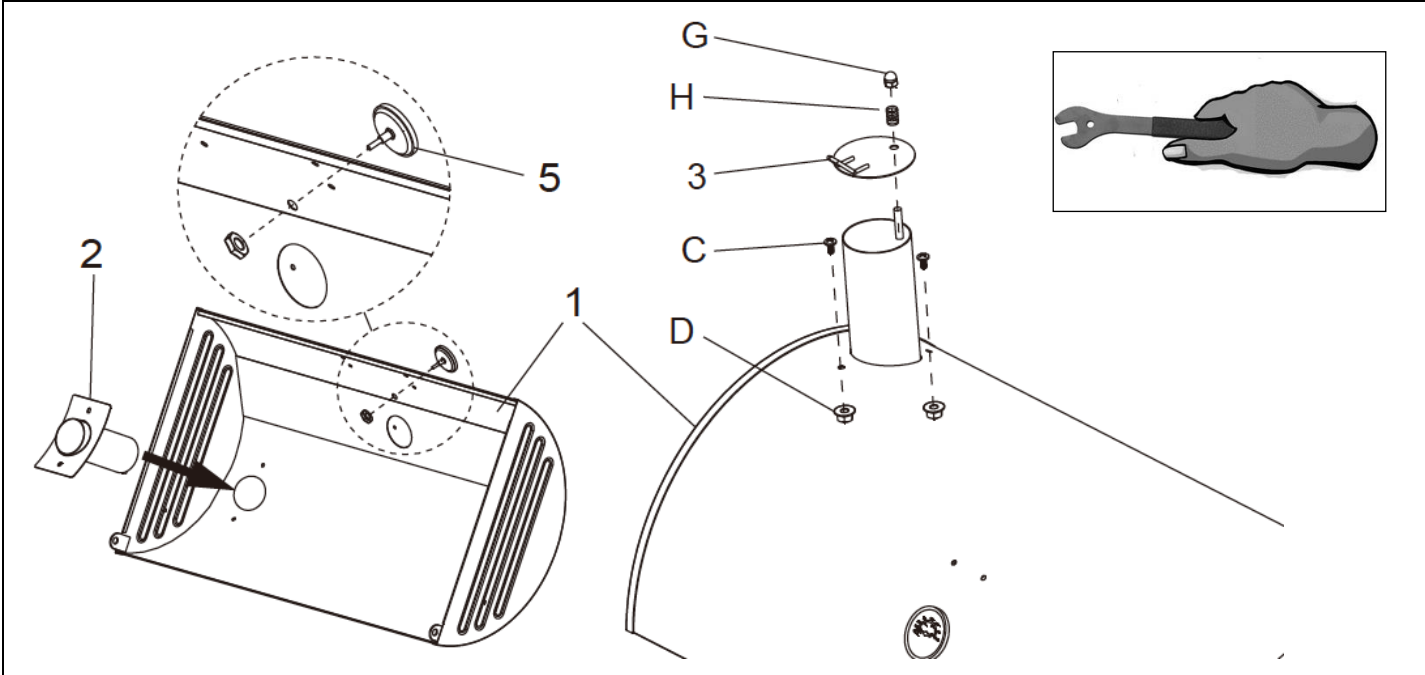

Step 14. Assembly handle (4) to the lid

Hardware required: Bolt C x 4 pcs, flange nut D x 4 pcs

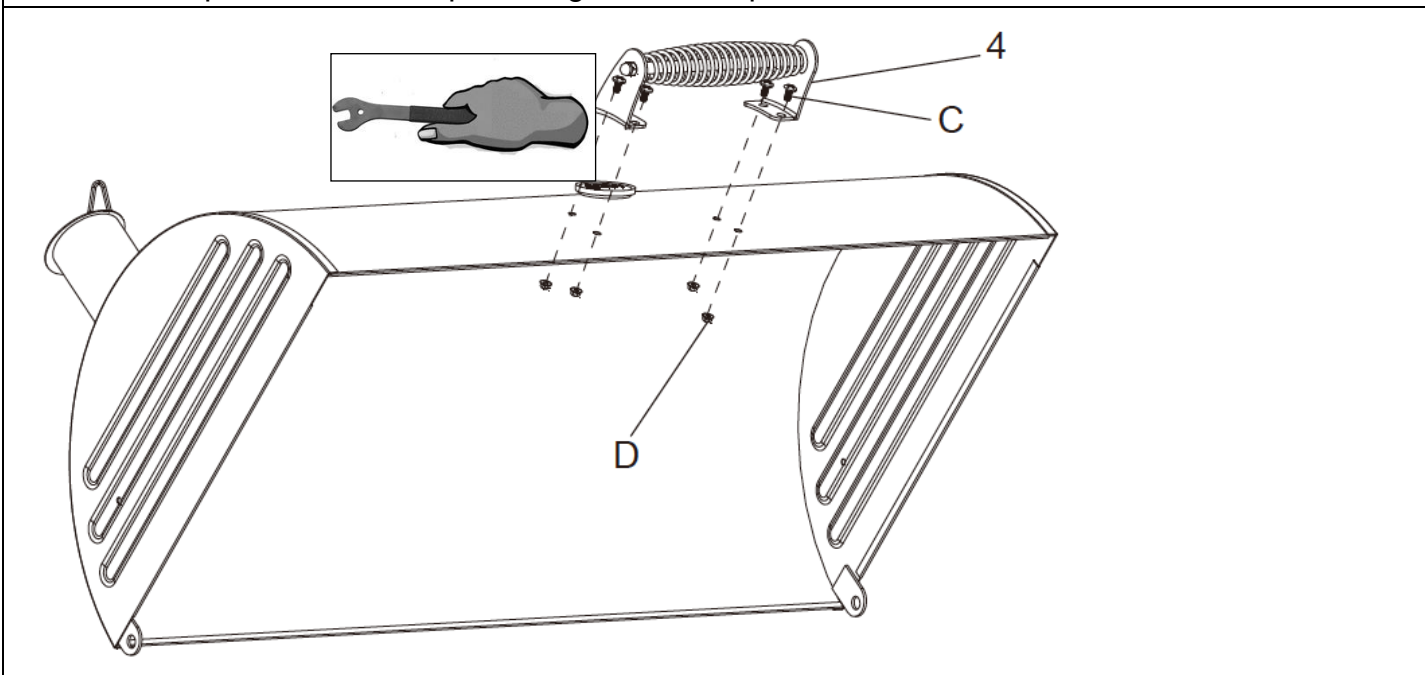

Step 15.Assembly lid to fire bowl.

Hardware required: Hinge Pin K x 2 pcs, cotter pin J x 2 pcs

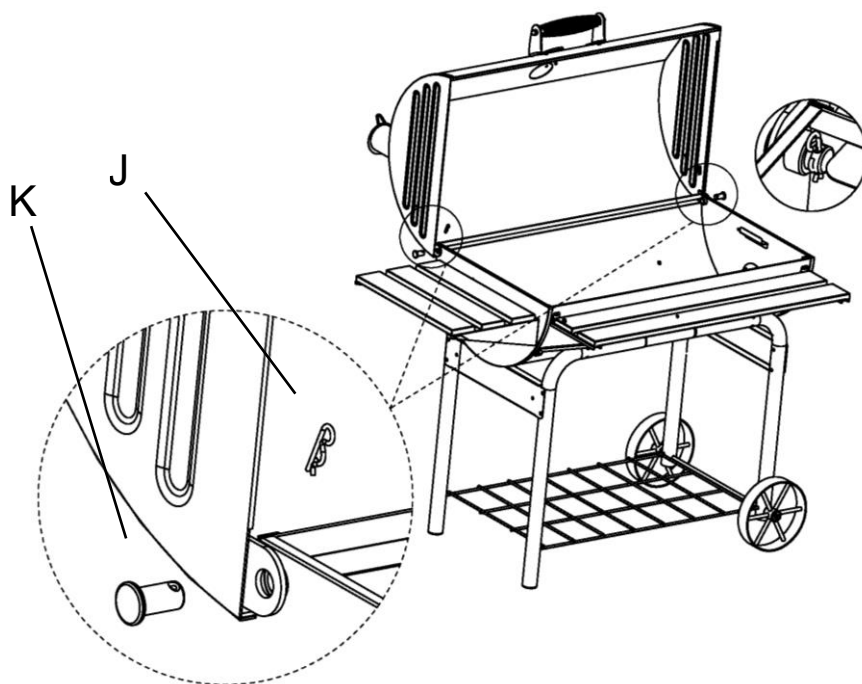

Step 16.Install charcoal tray(9) to fire bowl with charcoal tray hangers (8)

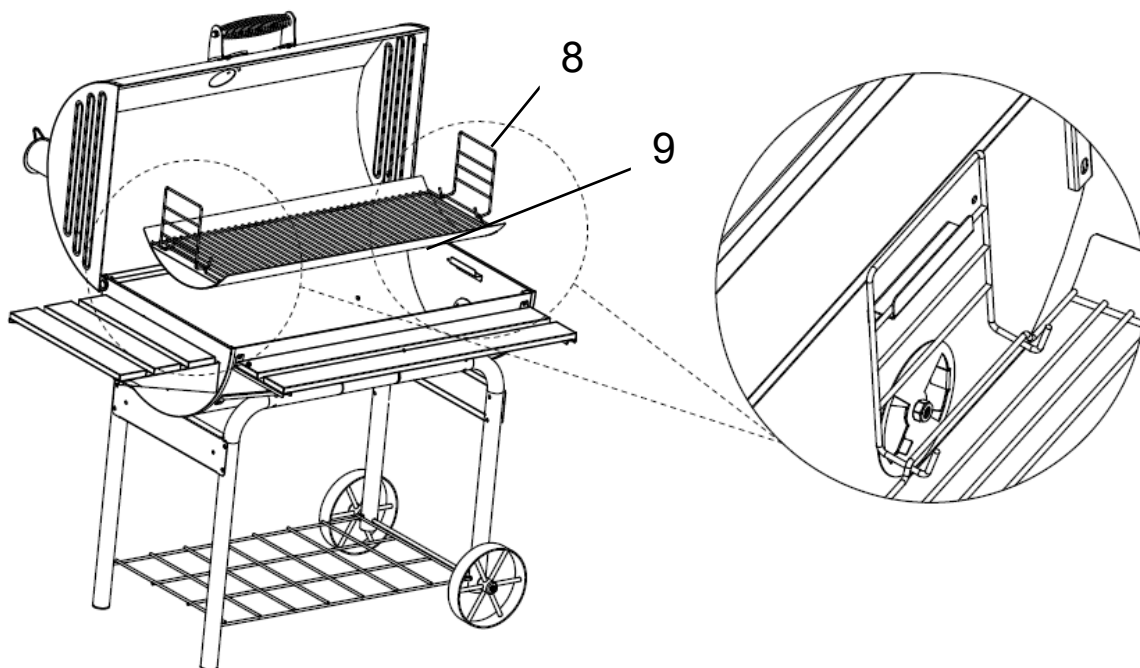

Step 17. Install warming rack (6) to grill lid and fire bowl.

Hardware required: Cotter pin (J) x 2 pcs

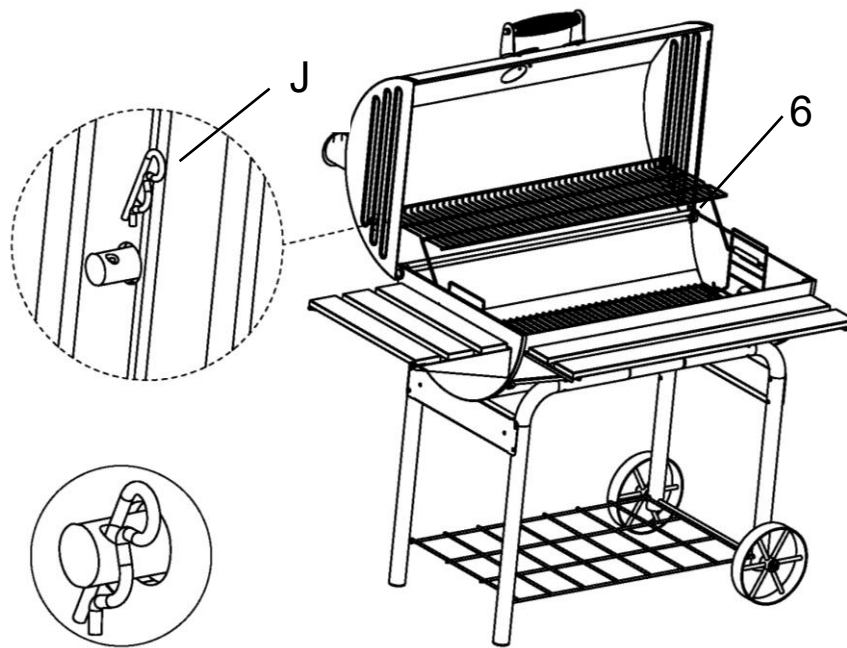

Step 18. Install cooking grid (7) to fire bowl. Also install the grease cup holder (23) to fire bowl underneath.

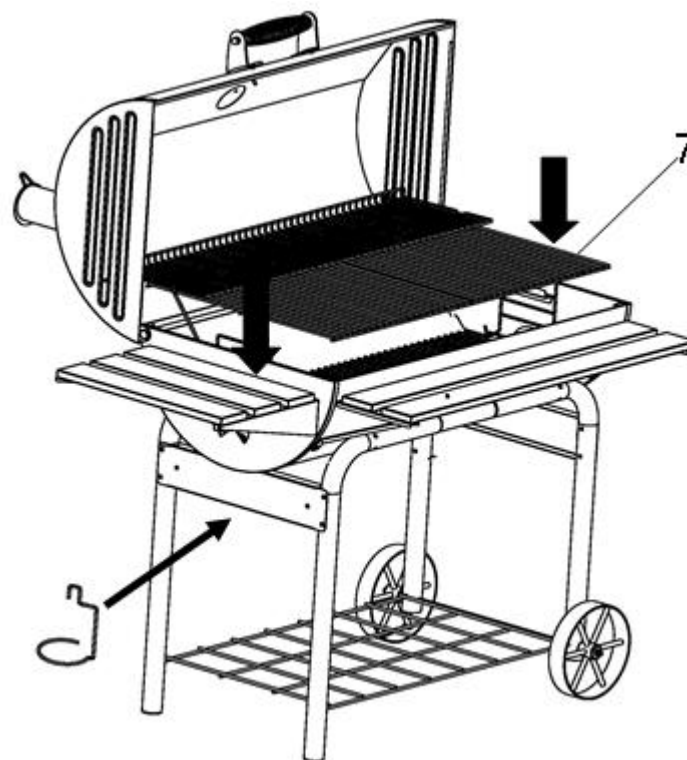

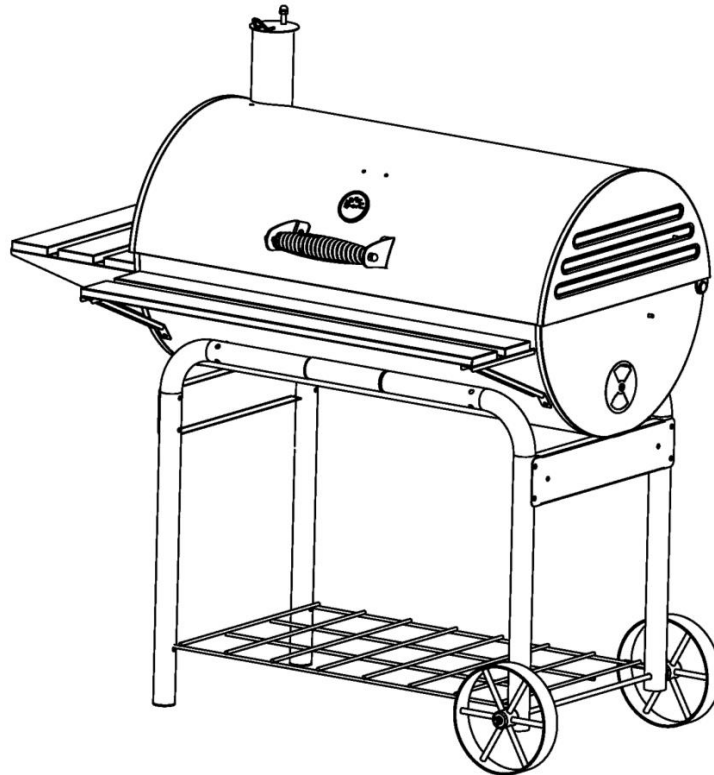

Final assembly



WARNING



Place the grill outdoors on a hard, level, non-combustible surface away from roof overhang or any combustible material. Never use on wooden or other surfaces that could burn. Place the grill away from open windows or doors to prevent smoke from entering your house. In windy weather, place the grill in an outdoor area that is protected from the wind.



WARNING



Read all safety warnings and instructions carefully before operating your grill.

PREPARATION FOR USE & LIGHTING INSTRUCTIONS

Curing your grill

Prior to your first use of the Grill, follow the instructions below carefully to cure your grill. Curing your grill will minimize damage to the exterior finish as well as get rid of the grill paint odor that can cause unnatural flavors to the first meal prepared on the grill.

IMPORTANT: To protect your grill from excessive rust, the unit must be properly cured and covered at all times when not in use.

Step 1

Lightly coat all interior surfaces of the grill with vegetable oil or vegetable oil spray. Do not coat charcoal grates or racks.

Step 2

Follow the instructions below carefully to build a fire. You may use charcoal and/or wood as fuel in the grill (see "Adding Charcoal/Wood During Cooking" section of this manual).

If using a Charcoal Chimney Starter, follow all manufacturer's warnings and instructions regarding the use of their product. Start with 3.5 pounds (1.59kg) of charcoal.

Instruction for reference only:

1. Begin with three full sheets of newspaper.
2. Take 2 sheets of newspaper and roll each into a tube shape and then give them a little twist to form each of them into a straight "rope" like shape. Be careful to not twist too tight.
3. Turn the charcoal chimney starter over and place both pieces of rolled and twisted newspaper along the inside bottom of the charcoal chimney starter to form a complete circle. Leave a hole in the middle of the charcoal chimney starter with no paper in it.
4. Crumple up the 3rd sheet of newspaper into a ball. Be careful to not crumple too tight. Sprinkle about 1 table spoon of cooking oil on the ball of newspaper. You can also use a few spritzes of cooking oil from a spray can. Don't use too much oil. Place the ball of cooking-oiled newspaper in the center of the charcoal chimney starter.
5. Flip the chimney over and add charcoal. Take care so that the newspaper does not fall out.
6. Use a match or long lighter to light the paper.
7. Stand back and watch the charcoal chimney starter do its stuff.
8. After charcoal has turned an ash gray color, carefully pour the charcoal onto your grill's fire grate.

NOTE: To extend the life of your grill, make sure that hot coals and wood do not touch the walls of grill.

IF USING CHARCOAL CHIMNEY STARTER, PROCEED TO STEP 5.

If you choose to use charcoal lighting fluid, ONLY use charcoal lighting fluid approved for lighting charcoal. Do not use gasoline, kerosene, alcohol or other flammable material for lighting charcoal. Follow all manufacturer's warnings and instructions regarding the use of their product. Start with 3.5 pounds (1.59kg) of charcoal. Place the charcoal in the center of each charcoal grate.

Step 3

Saturate charcoal with lighting fluid. With lid open, wait 2 to 3 minutes to allow lighting fluid to soak into charcoal. Store lighting fluid a safe distance from the grill.

Step 4

With grill lid open and charcoal grate completely placed inside the grill. Stand back and carefully light charcoal. Allow to burn until covered with a light ash (approximately 20 minutes).

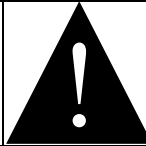
	<h1>WARNING</h1>	
<p>Charcoal lighting fluid must be allowed to completely burn off prior to closing grill lid (approximately 20 minutes). Failure to do this could trap fumes from charcoal lighting fluid in grill and may result in a flash-fire or explosion when lid is opened.</p>		

Step 5

With coals burning strong, close the lid. Allow the temperature to reach 225°F (107°C) on temperature gauge. Maintain this temperature for 2 hours.

Step 6

Increase the temperature to 400°F (205°C) on temperature gauge. This can be achieved by adding more charcoal and/or wood (see "Adding Charcoal/Wood During Cooking" section of this manual). Maintain this temperature for 1 hour then allow unit to cool completely.

NOTE: It is important that the exterior of the grill is not scraped or rubbed during the curing process.

IMPORTANT: to protect your smoker from excessive rust, the unit must be cured periodically and covered at all times when not in use.

OPERATING INSTRUCTIONS

Step 1

Lightly coat all interior surfaces of the grill with vegetable oil or vegetable oil spray. Do not coat charcoal grate or racks.

Step 2

Follow the instructions below carefully to build a fire. You may use charcoal and/or wood as fuel in the Barrel Grill (see “Adding Charcoal/Wood During Cooking” section of this manual).

If using a Charcoal Chimney Starter, follow all manufacturer’s warnings and instructions regarding the use of their product, start with 3.5 pounds (1.59 kg) of charcoal. When charcoal is burning strong, carefully place hot coals in center of each charcoal grate.

Instruction for reference only:

1. Begin with three full sheets of newspaper.
2. Take 2 sheets of newspaper and roll each into a tube shape and then give them a little twist to form each of them into a straight “rope” like shape. Be careful to not twist too tight.
3. Turn the charcoal chimney starter over and place both pieces of rolled and twisted newspaper along the inside bottom of the charcoal chimney starter to form a complete circle. Leave a hole in the middle of the charcoal chimney starter with no paper in it.
4. Crumple up the 3rd sheet of newspaper into a ball. Be careful to not crumple too tight. Sprinkle about 1 table spoon of cooking oil on the ball of newspaper. You can also use a few sprits of cooking oil from a spray can. Don’t use too much oil. Place the ball of cooking-oiled newspaper in the center of the charcoal chimney starter.
5. Flip the chimney over and add charcoal. Take care so that the newspaper does not fall out.
6. Use a match or long lighter to light the paper.
7. Stand back and watch the charcoal chimney starter do its stuff.
8. After charcoal has turned an ash gray color, carefully pour the charcoal onto your grill’s fire grate.

NOTE: to extend the life of your grill, make sure that hot coals and wood do not touch the walls of grill.

IF USING CHARCOAL CHIMNEY STARTER, PROCEED TO STEP 5.



If you choose to use charcoal lighting fluid, ONLY use charcoal lighting fluid approved for lighting charcoal. Do not use gasoline, kerosene, alcohol or other flammable materials for lighting charcoal. Follow all manufacturer’s warnings and instructions regarding the use of their product. Start with 3.5 pounds (approximate 1.59 kg) of charcoal. Place the charcoal in center of each charcoal grate.

Step 3

Saturate charcoal with lighting fluid. With lid open and charcoal grate completely placed inside the grill, wait 2 to 3 minutes to allow lighting fluid to soak into charcoal. Store charcoal lighting fluid a safe distance from the grill.

Step 4

With grill lid open, stand back and carefully light charcoal and allow to burn until covered with a light ash (approximately 20 minutes).

	<h1>WARNING</h1>	
<p>Charcoal lighting fluid must be allowed to completely burn off prior to closing grill lid (approximately 20 minutes). Failure to do this could trap fumes from charcoal lighting fluid in grill and may result in a flash-fire or explosion when lid is opened.</p>		

Step 5

Place cooking grates on grill support lips.

	<h1>WARNING</h1>	
<p>Always wear oven mitts/gloves when adjusting cooking levels to protect your hands from burns.</p>		

Step 6

Place food on cooking grates and close grill lid. Always use a meat thermometer to ensure food is fully cooked before removing from grill.

Step 7

Allow grill to cool completely, and then follow instructions in the “After-Use Safety” and “Proper Care & Maintenance” sections of this manual.

Flavoring Wood

To obtain your favorite smoke flavor, experiment by using chunks, sticks or chips of flavor producing wood such as hickory, pecan, apple, cherry, or mesquite. Most fruit or nut tree wood may be used for smoke flavoring. Do not use resinous wood such as pine as it will produce an unpleasant taste.

Wood chunks or sticks 3” to 4” (7 to 10 cm) long and 1” to 2” (2 to 4 cm) thick work best. Unless the wood is still green, soak the wood in water for 30 minutes or wrap each piece in foil and tear several small holes in the foil to produce more smoke and prevent the wood from burning too quickly. Only a few pieces of wood are required to obtain a good smoke flavor. A recommended amount for the grill is 5 to 6 wood chunks or sticks. Experiment by using more wood for stronger smoke flavor or less wood for milder smoke flavor.

Additional flavoring wood should not have to be added during the cooking process. However, it may be necessary when cooking very large pieces of food. Follow instructions and cautions in the “Adding Charcoal/Wood During Cooking” section of this manual to avoid injury while adding wood.

Regulating Heat

To increase heat, add more wood and/or charcoal. Follow instructions in “Adding Charcoal/Wood During Cooking” section of this manual.

To maintain the temperature, you may need to add more wood and/or charcoal during the cooking cycle.

NOTE: Dry wood burns hotter than charcoal, so you may want to increase the ratio of wood to charcoal to increase the cooking temperature. Hardwood such as oak, hickory, mesquite, fruit and nut wood are an excellent fuel because of their burning rate. When using wood as fuel, make sure the wood is seasoned and dry. DO NOT use resinous wood such as pine as it will produce an unpleasant taste.

The amount of food determines the amount of lump charcoal or charcoal briquette to be used. Add charcoal gradually and observe the grilling temperature via the temperature gauge. Adding too much charcoal into the grill at a time may raise the burning temperature rapidly and cause damages to the grill.

Adding Charcoal/Wood During Cooking

Additional charcoal and/or wood may be required to maintain or increase cooking temperature.

Step 1

Stand back and carefully open grill lid. Use caution since flames can flare-up when fresh air suddenly comes in contact with fire.

Step 2

Wearing oven mitts/gloves, lift up the cooking grates and place it on a clean and non-combustible surface. DO NOT touch the grates by hand.

Step 3



Stand back a safe distance and use long cooking tongs to lightly brush aside ashes on hot coals. Use cooking tongs to add charcoal and/or wood to charcoal grates, being careful not to stir-up ashes and sparks. If necessary, use your Charcoal Chimney Starter to light additional charcoal and/or wood and add to existing fire.

	<h1>WARNING</h1>	
<p>Never add charcoal lighting fluid to hot or even warm coals as flashback may occur causing severe burns.</p>		

Step 4

When charcoal is burning strong again, wear oven mitts/gloves and carefully return the charcoal grates to grill body. Extinguish any hot ashes, coals or embers which may have fallen from the grill or beneath and around grill using water hose.

AFTER-USE SAFETY

	<h1>WARNING</h1>	
<ul style="list-style-type: none">● Always allow grill and all components to cool completely before handling.● Never leave coals and ashes in grill unattended. Make sure coals and ashes are completely extinguished before removing.● Before grill can be left unattended, remaining coals and ashes must be removed from grill. Use caution to protect yourself and property. Place remaining coals and ashes in a non-combustible metal container and completely saturate with water. Allow coals and water to remain in metal container 24 hours prior to disposing.● Extinguished coals and ashes should be placed a safe distance from all structures and combustible materials.● With a garden hose, completely wet surface beneath and around the grill to extinguish any ashes, coals or embers which may have fallen during the cooking or cleaning process.● Cover and store grill in a protected area away from children and pets.		

Proper Care & Maintenance

- Cure your grill periodically throughout the year to protect against excessive rust.
- To protect your grill from excessive rust, the unit must be properly cured and covered at all times when not in use.
- Wash cooking grates and charcoal grates with hot, soapy water, rinse well and dry. Lightly coat grates with vegetable oil or vegetable oil spray.
- Clean inside and outside of grill by wiping off with a damp cloth. Apply a light coat of vegetable oil or vegetable oil spray to the interior surface to prevent rusting. Do not coat charcoal grates or charcoal grates.
- If rust appears on the exterior surface of your grill, clean and buff the affected area with steel wool or fine grit emery cloth. Touch-up with a good quality high-temperature resistant paint.
- Never apply paint to the interior surface. Rust spots on the interior surface can be buffed, cleaned, and then lightly coated with vegetable oil or vegetable oil spray to minimize rusting.

LIMITED WARRANTY

1. Manufacturer warrants this Product to be free from defects in workmanship and materials for a period of Ninety (90) days from the date of purchase, PROVIDED claims are submitted, in writing, with proof of purchase.
2. If any part of this item fails because of a manufacturing defect within the Limited Warranty Period, Manufacturer offers to replace such part(s) provide that such parts have not been improperly repaired, altered, or tampered with or subject to misuse, abuse or exposed to corrosive conditions. This Limited Warranty is, however, subject to certain limitations, exclusions, time limits and exceptions (Hereinafter "Conditions") as listed below. Read these Conditions carefully.
3. This Limited Warranty shall be limited to the replacement or repair of any part(s) which Manufacturer determines, after reasonable examination, to have been defective at the time of manufacturing and manufacturer's obligation(s) shall be limited to replacement, if any, of defective part(s) which shall be shipped at Original Purchaser's expense to Original Purchaser's designated shipping address.
4. This Limited Warranty is given to and covers the **ORIGINAL PURCHASER ONLY** and such coverage terminates Ninety (90) days from the date of purchase.
5. **DAMAGE LIMITATION WARNING:** IN NO EVENT SHALL MANUFACTURER BE LIABLE FOR ANY INCIDENTAL OR CONSEQUENTIAL DAMAGES, INCLUDING (BUT NOT LIMITED TO) LOSS OF USE OF THE PRODUCT, LOSS OF TIME, LOSS OF FOOD, INCONVENIENCE, EXPENSES FOR TRAVEL, TRANSPORTATION LODGING EXPENSES, LOSS BY DAMAGE TO PERSONAL PROPERTY OR LOSS OF INCOME, PROFITS OR REVENUE.
6. **MANUFACTURER'S OBLIGATION:** Manufacturer's liability shall be limited to the delivery of a good, merchantable Product and, if necessary, the repair or replacement, at manufacturer's option, of any defective part or unit.
7. **TRANSFER LIMITATIONS:** This Limited Warranty is not assignable or transferable. It covers only the original purchaser.
8. **RESERVED RIGHT TO CHANGE:** Manufacturer reserves the right to make changes or improvements to products it produces in the future without imposing on itself any obligations to install the same improvements in the products it has previously manufactured.
9. This Limited Warranty gives the Original Purchaser specific legal rights but there may be other rights which vary by jurisdiction.
10. This warranty does not cover the following items:
 - Chips or scratches on porcelain or painted surfaces.
 - Rust or corrosion is not deemed a manufacturing or materials defect.
 - Discoloration or loss of paint due to handling during assembly, heat or cleaning products. Paint may require touch up.
 - Stainless steel discoloration or corrosion.
 - Consumables such as batteries.

IF CUSTOMER SERVICE BECOME NECESSARY:

1. The Original Purchaser is responsible for shipping and handling charges of the returned item(s) and replacement parts, if any.
2. All parts to be replaced will need to be shipped before replacement items will be sent.
3. Follow the Customer Service Representative's instructions exactly. If a return is necessary, it must be packed carefully and shipped prepaid.

Optional Custom Cover Available

Please visit www.homedepot.com
for more information

Model #: AC2256201-RG
Stampede Grill Cover



Should you encounter any problem,

Or

To obtain replacement parts

CALL US FIRST.

Do not return product to the store.

WE CAN HELP.

Rankam (China) Manufacturing Company Limited

Address: 18/F, New Lee Wah Centre, 88 Tokwawan Road, Kowloon, Hong Kong.

Please contact Customer Service at

customerservice@rankam.com

or at

1-888-837-1380,

Hours of Operation: Mon to Fri, 8:00 a.m. – 5:00 p.m. Pacific Standard Time.

Made in China