

This Owner's Manual is provided and hosted by [Appliance Factory Parts](#).



MAGIC CHEF EWWC16MCG Owner's Manual

[Shop genuine replacement parts for MAGIC CHEF
EWWC16MCG](#)



[Find Your MAGIC CHEF Refrigerator Parts - Select From 316 Models](#)

----- Manual continues below -----

Wine Cooler

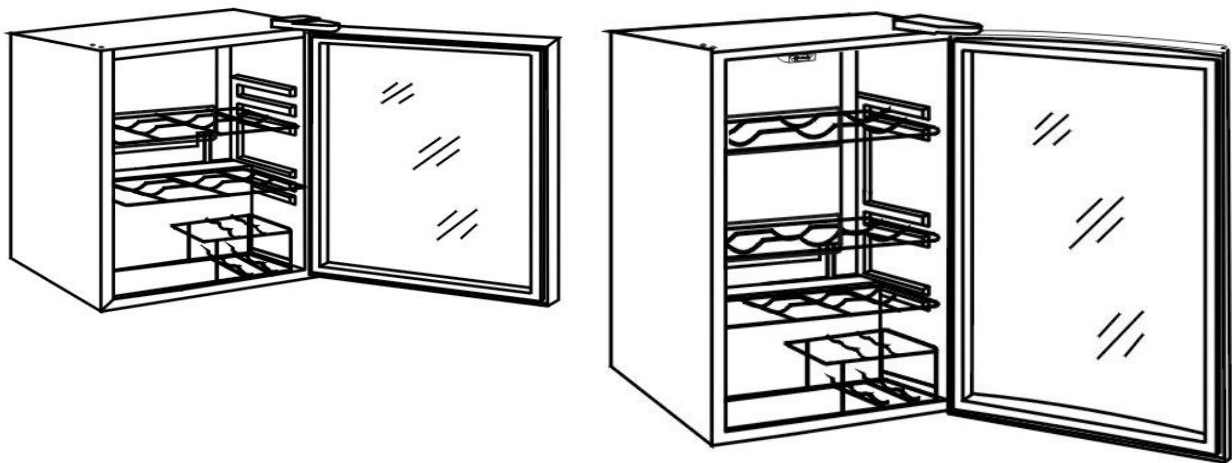

Model No. EWWC16MCG EWWC30MCG

Wine Cooler

▪ Before Putting Into Use	2
▪ Important	3
▪ Placing and Installation	4
▪ Description of the Appliance	5
▪ Temperature Control	5
▪ Maintenance and Cleaning	7
▪ Trouble Shooting Guide	8
▪ Changing The Reversible Door	10
▪ Wine Cooler Warranty	11

CAUTION:

Read and follow all safety rules and operating instructions before first use of this product.

Wine Cooler

Thank you for buying this appliance.

We hope it will successfully serve your requirements for many years.

SAVE THESE INSTRUCTIONS

Before Putting Into Use	2
To Assemble Door Handle	
Instructions for Use	
Tips for Energy Savings	
Important	3
Disposing of Worn Out Appliances	
Placing and Installation	4
Choosing the Right Place	
Placing the Self-standing Appliance	
Connection to Power Supply	
Description of the Appliance	5
Temperature Control	5
Temperature Selection	
Illustration of the Appliance	
Maintenance and Cleaning	7
Automatic Defrosting of the appliance	
Cleaning of the Appliance	
Switch Off the Appliance When Not In Use	
Trouble-Shooting Guide	8
Changing The Reversible Door	10
Wine Cooler Warranty	11

Before Putting Into Use

To Assemble Door Handle

(Door handle assembling for EWWC16MCG & EWWC30MCG)

To save shipping space and avoid damage of the unit during transportation, the door handle of this unit is shipped unassembled. Before putting the unit into use you are kindly asked to assemble the door handle as follows:

- Locate the door handle and 2 screws attached inside the cabinet, and prepare an appropriate screwdriver.
- With the 2 screws attached, fasten the door handle onto the frame of the door panel as illustrated. Be sure that the screws must point to the holes on the frame of the door panel when doing so.

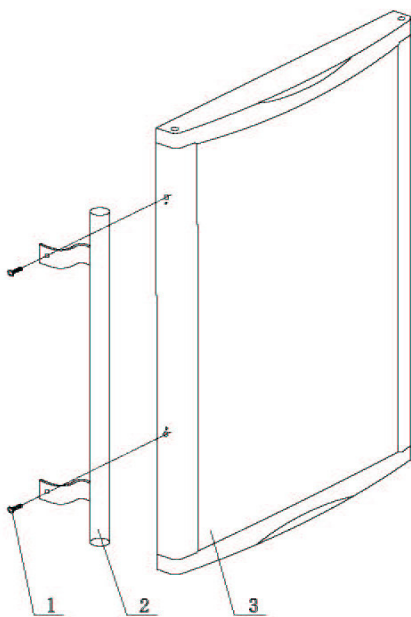

1、 Screw 2、 Door handle 3、 Door panel

- Before connecting the appliance to electrical power supply, leave it to stand for about 4 hours, which will reduce the possibility of malfunctions in the cooling system due to transport handling.
- Clean the appliance thoroughly, especially in the interior (See Cleaning and Maintenance).
- In case the interior accessories are not correctly placed, rearrange them as described in chapter "Description of the Appliance".

Instructions for Use

These instructions for use are intended for the user. They describe the appliance and correct operating procedures for safe use .

SAVE THESE INSTRUCTIONS:

Tips for Energy Saving

- Try not to open the door too often, especially when the weather is hot and humid. Once you open the door , close it as soon as possible. This is especially important if you have an upright model .
- Every now and then check if the appliance is sufficiently ventilated (adequate air circulation behind the appliance) .
- Set the thermostat from higher to lower settings as soon as possible (depends on how loaded the appliance is, ambient temperatures etc.).
- If the gasket is damaged or the door seal is poor, energy consumption is substantially higher. To restore efficiency, replace the gasket.
- Always consider instructions stated in sections Positioning and Energy Saving Tips, otherwise the energy consumption is substantially higher.

Important

If you have bought this appliance to replace an old one equipped with a door lock that cannot be opened from the inside (lock, bolt), make sure that the lock is removed, disabled or destroyed before discarding. This will make it impossible for children to accidentally lock themselves inside the appliance and suffocate. To avoid risk of child entrapment, leave the shelves in place so children can not easily climb inside even when the appliance is in routine use or not in use at home.

The appliance must be properly connected to an electrical power supply. (See: Connection to Power Supply) .

Do not use an extension cord.

Always disconnect the appliance from the power supply before cleaning the appliance, or attempting repairs.

WARNING:

Repairs should be performed by qualified service personnel only.

Do not defrost the appliance with other electric appliances (for example a hair dryer) and never attempt to scrape/remove ice/frost with sharp objects.

The cooling system of the appliance is filled with refrigerant and oil ,so when the appliance is damaged, handle it with care and dispose of it in compliance with environmental protection safeguards.

The rating plate containing Model No and other technical data specific to this unit, is located either inside the appliance or outside on the rear wall.

Disposing of Worn Out Appliances

- **DANGER OR WARNING:** Risk of child entrapment. Before you throw away your old refrigerator or freezer:
 - Take off the doors
 - Leave the shelves in place so children may not easily climb inside.

- The cooling system of the appliance is filled with refrigerant and insulating substances which should be separately treated and processed. Call your nearest authorised service agent. If you are unable to locate one, contact your local authorities or your distributor. Be careful not to damage the tubes on the rear wall of the appliance (danger of pollution).

Placing and Installation

CHOOSING THE RIGHT PLACE

Place the appliance in a dry and regularly ventilated room. Never place the appliance near heat emitting devices (e.g. cooking appliances, radiators, water heaters or similar devices) and do not expose to direct sunlight.

The appliance should be positioned at least 2in. away from electric or gas cooking appliances and at least 12in. away from oil or coal fired stoves. If this is not possible, use an appropriate insulation barrier.

Behind the appliance there should be a free space of at least 3in. . Kitchen units (cupboards) should be at least 2in. away from the appliance in order to assure adequate ventilation. There should be 4in. between both sides of the cooler and other article.

INSTALLATION

Place the appliance firmly on a solid base. Some appliances have adjustable feet on the front side; use them to level the appliance.

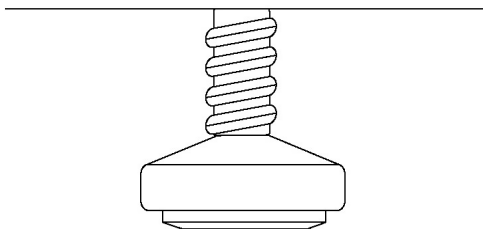

WARNING

Instructions to avoid to the risk of fire , electric shock , or injury to persons.

WIRING INSTRUCTIONS

For your personal safety, this appliance must be grounded. In the event of a malfunction or breakdown, grounding will reduce the risk of electric shock by providing a path of least resistance for electric current. This appliance is equipped with a power cord having a grounding conductor. The plug must be plugged into an appropriate wall outlet that is installed and wired in accordance with all existing local codes and ordinances. Consult a qualified electrician or serviceman if the wiring instructions are not clearly understood, or if doubt exists as to whether the appliance is properly grounded.

CONNECTION TO POWER SUPPLY

Connect the appliance power cord and plug to a properly grounded wall outlet. The required nominal voltage and frequency are indicated on the rating plate (inside the unit or on the exterior rear wall of the unit).

Description of the appliance

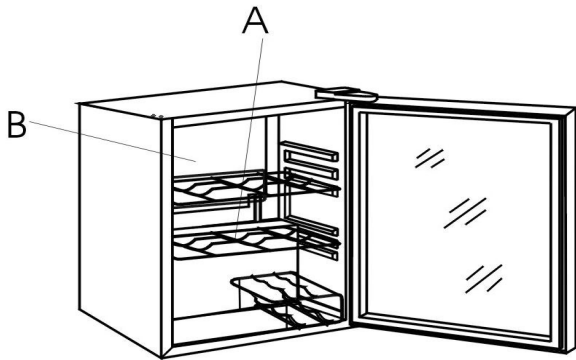

(A) Adjustable Wine Shelves

(For EWWC16MCG only)

Shelves can be optionally placed on the guides inside the appliance where appropriate. Perishable items should be stored towards the back/rear of the shelves. i.e. the coldest part of the shelf.

(B) Defrost Water Outlet

The interior of the appliance is cooled with a cooling plate mounted in the rear wall. Under the plate there is a channel and an outlet for defrost water. Regularly check the defrost water outlet and the drain channel for blockage. They should always be kept free and clean of particles.

WE RESERVE THE RIGHT TO ALTER THE SPECIFICATIONS WITH NO EFFECT ON THE OPERATION OF THE APPLIANCE.

Temperature Control

The temperature of the appliance is controlled by setting the thermostat knob to a desired setting.

Temperature Selection

To start the appliance turn the temperature control knob to the position corresponding to the desired cooling.

Fig A (EWWC16MCG) see page 6

Fig B (EWWC30MCG) see page 6

The temperature will vary depending on the quantity of the item stored and on the frequency with which the door is opened.

To turn the control to the "OFF" position, rotate the control knob to the "0" position. If the appliance has been left out of use for some time, set the control to maximum or the "7" position for 2-3 hours before turning to the desired position. If the appliance is not being used for long time periods, disconnect the plug and leave the door partially open. This will help to reduce mold/mildew from accumulating inside the appliance cabinet.

Warning: Never set the temperature control to maximum or "7" position for more than 8 hours.

CONTROL KNOB

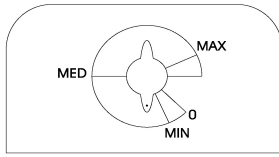

Fig A (EWWC16MCG)

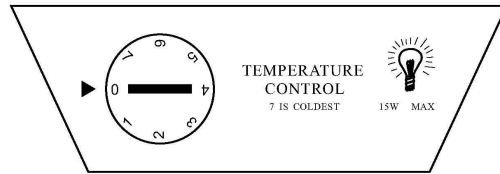

Fig B (EWWC30MCG)

- Changes in ambient room temperature will affect the internal temperatures (choose correct setting of the thermostat knob).
- In STOP (0) position the appliance does not operate (cooling system is switched off), yet power supply is not interrupted.
- Temperature in the appliance also depends on how often the door is opened.

ILLUSTRATION OF THE APPLIANCE

1. THERMOSTAT DIAL:

For controlling the temperature inside the wine cooler. Turns the motor on as soon as the temperature rises above the desired level.

2. PLASTIC COATED OR CHROMED SHELVES:

Odor resistant, rustproof, and removable for easy cleaning.

3. MAGNETIC GASKET: Tight fitting door seal keeps all the cooling power locked inside. No hooks or latches.

4. TEMPERED GLASS DOOR & INTERIOR LIGHT:

Allows easy interior visibility.

(Interior light for EWWC30MCG only)

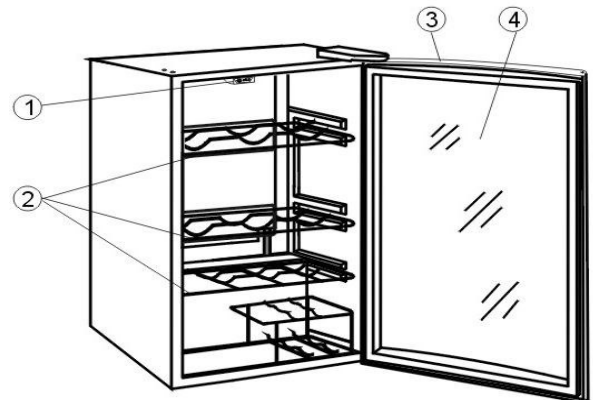
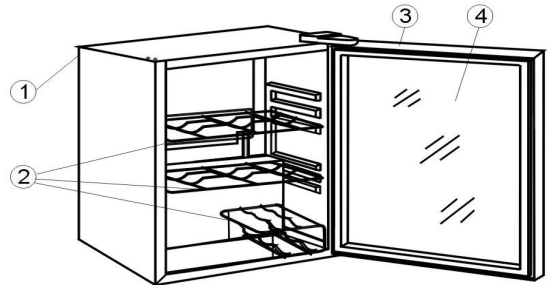

TEMPERATURE RANGE GUIDE:

Generally, the cabinet temperature range is between 8-15 °C (+/-3 °C) {46-59 °F (+/-5 °F)} for storage of wine bottles.

The thermostat setting of '1' or 'MIN' is the warmest.

The thermostat setting of '7' or 'MAX' is the coldest.

For storage of red wine, the thermostat setting of '2' or near 'MIN' is recommended.

For storage of white wine, the thermostat setting of '6' or near 'MAX' is recommended.

Maintenance and Cleaning

Automatic Defrosting of the Appliance

There is no need to defrost the cooler , because ice depositing on the inner back wall is defrosted automatically.

Ice build-up on the inner back wall during the compressor operation will defrost automatically (when the compressor has cycled off) . Defrost water will drain out passing through the drain outlet in the inner back wall into a drain pan situated above the compressor, from where it evaporates.

Switch Off the Appliance When Not In Use

If you do not intend to use the appliance for long periods of time. Set the thermostat knob to the STOP (0) position, disconnect the power supply, take out the contents and defrost and clean the appliance. Leave the door slightly open.

Cleaning the Appliance

Disconnect the power supply before cleaning the appliance.

Do not use coarse or aggressive cleaning agents as you may damage the surface.

Clean the exterior with water and detergent.

Remove the detachable accessories in the interior of the appliance and clean with water and liquid detergent. Plastic parts cannot be washed in dishwashers.

Wash the interior of the appliance with lukewarm water , adding one or two spoonfuls of vinegar.

After cleaning, connect the appliance to power supply and reload it.

Trouble-Shooting Guide

- Sometimes you may come across minor problems that in most cases do not require a service call and can be easily eliminated. The problem may have resulted from improper handling and / or installation of the appliance. Please refer to the below trouble-shooting guide to assist you in identifying the possible cause and solution to your problem. Should the problem still persist after completing these checkpoints, contact the closest authorized service agent in your area for assistance.

The Appliance Fails to Operate After Connecting to Electrical Power Supply

- Check the power cord is properly connected.
- Check the power supply in the electrical outlet. (blown fuse / circuit breaker) .
- Make sure the appliance is switched on. (thermostat knob in operating position)

Continuous Operation of the Cooling System

- The door is frequently opened or left open for too long.
- The door is not properly closed (the door may sag, the gasket may be polluted or damaged).
- appliance.
- the compressor (assure adequate air circulation).

Ice Formation on the Inner Rear Wall

As long as the defrost water runs to the channel and through the outlet to the drain pan on the compressor, automatic defrosting of the appliance is assured.

In case the ice formation on the inner back wall is increased (1/8-1/5in.), ice should be manually defrosted.

Set the thermostat knob to **STOP (0)** position and leave the door open. Never use electric devices for defrosting and do not scrape the ice or frost layer with sharp objects.

After defrosting is complete, turn the knob to desired position and close the door. The cause of increased ice formation may be one of the following:

- the door does not seal well (clean the gasket if it is contaminated, or replace it if it is damaged);
- the door is frequently opened or left too long;
- the food stored in the appliance was warm;
- the food or dish is touching the inner back wall.

Changing The Reversible Door

CAUTION: To avoid personal injury to yourself and/or property, we recommend someone assist you during the door reversal process.

1. Remove the top hinge assembly and keep them for future use.
2. Remove the bottom hinge assembly and keep them for later use.
3. Remove the plug buttons from the upper left holes and transfer them to the uncovered holes at the right side. Be sure to press the plug buttons firmly into the holes.
4. Take out a new set of top hinge assembly attached and install on the opposite side.
5. Re-install the bottom hinge assembly previously removed in step 2 on the opposite side.
6. Make sure the door assembly is properly aligned on the cabinet before tightening the screws.
7. Remove the door handle and re-install on the opposite side.
8. Remove the plug buttons from the right doorframe and transfer them to the uncovered holes at the left side. Be sure to press the plug buttons firmly into the holes.

The process is now complete.

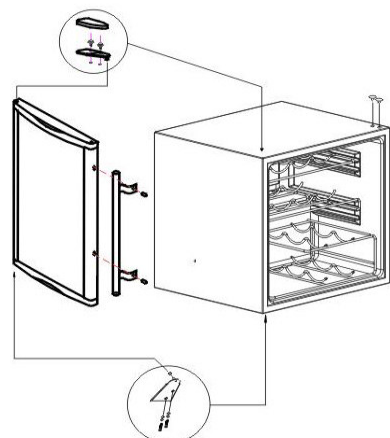
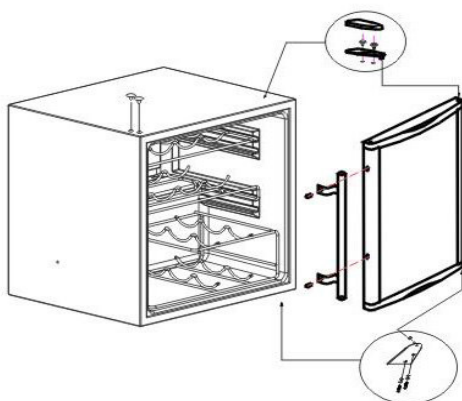
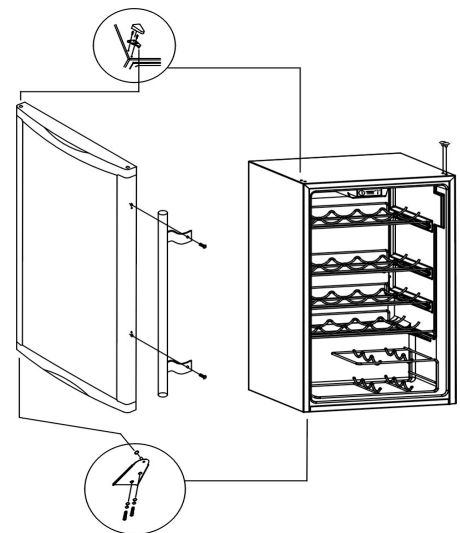
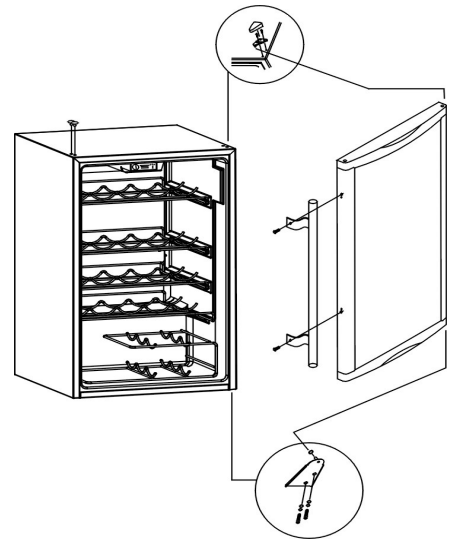

Changing The Reversible Door

CAUTION: To avoid personal injury to yourself and/or property, we recommend someone assist you during the door reversal process.

1. Remove the top hinge assembly and keep them for future use.
2. Remove the bottom hinge assembly and keep them for later use.
3. Remove the plug buttons from the upper left holes and transfer them to the uncovered holes at the right side. Be sure to press the plug buttons firmly into the holes.
4. Take out a new set of top hinge assembly attached and install on the opposite side.
5. Re-install the bottom hinge assembly previously removed in step 2 on the opposite side.
6. Make sure the door assembly is properly aligned on the cabinet before tightening the screws.
7. Remove the door handle and re-install on the opposite side.
8. Remove the plug buttons from the right doorframe and transfer them to the uncovered holes at the left side. Be sure to press the plug buttons firmly into the holes.

The process is now complete.

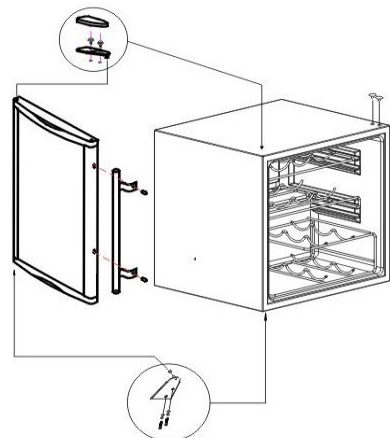
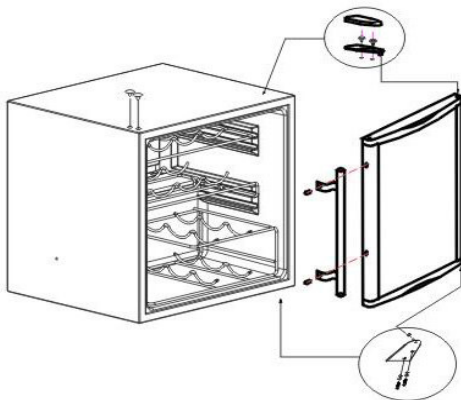
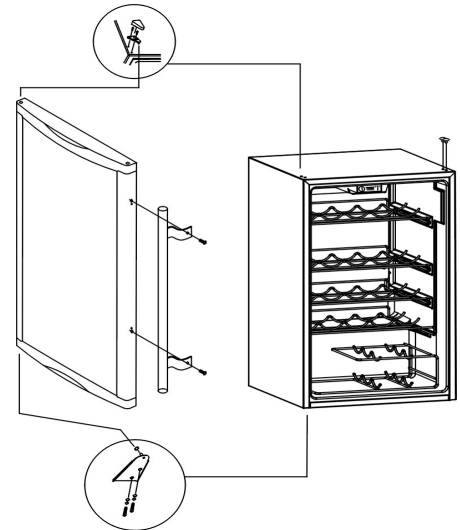
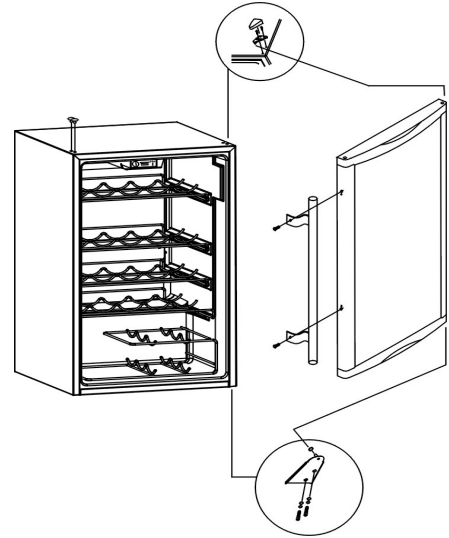



Wine Cooler Warranty

MC Appliance Corp. warrants each new Wine Cooler to be free from defects in material and workmanship and agrees to remedy any such defect or to furnish a new part(s) (at the company option) for any part(s) of the unit that has failed during the warranty period. Parts and labor expense are covered on this unit for a period of one year after the date of purchase. In addition **MC Appliance Corp.** warrants the compressor (parts only) to be free from defects in material and workmanship for a period of 5 years. The consumer is responsible for all labor and transportation expenses related to the diagnosis and replacement of the compressor after the initial one- year warranty expires. If in the event the unit requires replacement or refund under the terms of this warranty the consumer is responsible for all transportation expenses to return the unit to our factory prior to receiving a replacement unit or refund. **A copy of the dated sales receipt / invoice is required to receive warranty service.**

This warranty covers appliances in use within the continental United States, Puerto Rico and Hawaii. The warranty does not cover the following:

- . Damages due to shipping damage or improper installation.
- . Damages due to misuse or abuse.
- . Content losses due to failure of the unit.
- . Inside components such as door panels, door shelves, racks, light bulbs, etc.
- . Punctures to the evaporator system due to improper defrosting of the unit.
- . Repairs performed by unauthorized service agents.
- . Service calls that do not involve defects in material and workmanship such as instruction on proper use of the product, door reversal or improper installation.
- . Replacement or resetting of house fuses or circuit breakers.
- . Failure of this product if used for other than its intended purpose.
- . Disposal costs of failed units not returned to our factory.
- . Any delivery costs incurred as the result of a unit that fails to perform as specified.

This warranty is in lieu of all warranties expressed or implied and no representative or person is authorized to assume for us any other liability in connection with the sale of this product. Under no circumstances is the consumer permitted to return this unit to the factory without prior written consent from **MC Appliance Corp.**

Model	Parts	Labor	Compressor (Part Only)	Type of Service
EWWC16MCG	One-Year	One-Year	Five Years	Carry In
EWWC30MCG	One-Year	One-Year	Five Years	In Home

For Service or Assistance please call 888 775-0202 or visit us on the web at www.magicchef-ewave.com.