

 **LYNX**<sup>®</sup>

SMARTGRILL USER MANUAL

# WARNINGS



## WARNING

READ THIS MANUAL CAREFULLY and completely before using your grill to reduce the risk of:

1. Fire
2. Burn hazard, personal injury or property damage
3. Ruined steaks or other unpleasant cooking experiences
4. Unapproved installation or servicing.

THIS PRODUCT IS DESIGNED FOR OUTDOOR USE ONLY. Improper installation, adjustment, alteration, service or maintenance can cause property damage, injury or death.

Read this manual thoroughly before installation, use, or servicing of this product.



## DANGER

### IF YOU SMELL GAS:

1. Shut off all gas supply lines to the grill.
2. Extinguish any open flames.
3. Carefully open the lid. Remember, it may be extremely hot!
4. If odor continues, keep everyone away from the grill and immediately call your gas supplier or your fire department.



## AVERTISSEMENT

### S'IL Y A UNE ODEUR DE GAZ:

1. Coupez l'admission de gaz de l'appareil.
2. Éteindre toute flamme nue.
3. Ouvrir le couvercle. Rappelez-vous qu'il peut être extrêmement chaude.
4. Si l'odeur persiste, éloignez-vous de l'appareil et appelez immédiatement le fournisseur de gaz ou le service d'incendie.



## WARNING

1. DO NOT store or use gasoline or other flammable vapors and liquids in the vicinity of this or any other appliance.
2. A liquid propane cylinder not connected for use shall not be stored in the vicinity of this or any other appliance.



## AVERTISSEMENT

1. Ne pas entreposer ni utiliser de l'essence ni d'autres vapeurs ou liquides inflammables dans le voisinage de l'appareil, ni de tout autre appareil.
2. Une bouteille de propane qui n'est pas raccordée en vue de son utilisation, ne doit pas être entreposée dans le voisinage de cet appareil ou de tout autre appareil.



## WARNING! CALIFORNIA PROPOSITION 65

1. The burning of gas cooking fuel generates some by-products which are on the list of substances which are known by the State of California to cause cancer or reproductive harm.
2. California law requires businesses to warn customers of potential exposure to such substances. To minimize exposure to the substances, always operate this unit according to the use and care instructions found in this manual. Be certain to provide adequate ventilation when cooking.
3. California Proposition 65 lists "Silica, crystalline" which is used in one of the components of the IR burner, as an agent known to the state of California to cause cancer.

# QUICK START POWER CONNECTIVITY & WI-FI SET UP PROCESS\*

## STEP #1—REQUIREMENTS

- Smart device (phone or tablet)
- 110 volt GFIC outlet at the grill
- Proper gas supply
- Home network name (SSID) & password

Name: \_\_\_\_\_

Password: \_\_\_\_\_

- SmartGrill by Lynx™ serial number/PIN\*

Serial number: \_\_\_\_\_

PIN: \_\_\_\_\_

\*Located on the top of your PC case.



iPhone 5 or greater or iPad version 2.0 or greater



Android 4.4 or greater

## STEP #2—SETUP YOUR SMARTGRILL

- If not already done, locate the 6 wire connections inside the grill and attach them to the SmartGrill computer case. Each cable is labeled to coincide with the port on the SmartGrill computer. Please be sure to connect the cables as per labeling on cable and computer.
- Locate the antenna in the white box inside the grill and screw into the back of the SmartGrill computer case.
- Plug the power cable from the SmartGrill into a 110v GFIC electrical outlet.
- Wait 20-60 seconds for the SmartGrill to complete boot up and say "SmartGrill, ready".

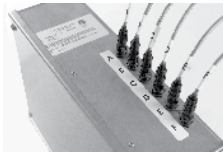

## STEP #3—DOWNLOAD AND SETUP THE SMARTGRILL APP ON YOUR PHONE OR TABLET AND CREATE YOUR ACCOUNT



- Go to iTunes or Google Play and download "SmartGrill by Lynx" and install
- Open the SmartGrill App and click **Create Account** then enter your grill serial number and PIN then click **Continue**.
- Enter your email address, password and your registration information and click **Create Account**. You will get a confirmation email.

- Open the confirmation email and follow instructions to activate your account.
- Now login to the SmartGrill app by entering your email and password.

## STEP #4—SETUP WI-FI CONNECTIVITY

- On your Phone or Tablet, verify that you have at least 60% wireless signal at your SmartGrill.
- On your SmartGrill, press the power button and wait about 30 seconds for the SmartGrill to say "**Please setup your Wi-Fi connection,**" then "**SmartGrill, at your service**".



- On your phone or tablet, switch to your Wi-Fi settings and locate the wireless network called **SmartGrill xxxx** (xxxx is the last four digits of your serial number) and connect to it. The password is **lynxgrill**.



- Now go back to your SmartGrill App and go to the **Resources** icon, then **My Smart Grill**  **SmartGrill Wi-Fi Setup** . Wait 10-20 seconds for the wi-fi setup menu.

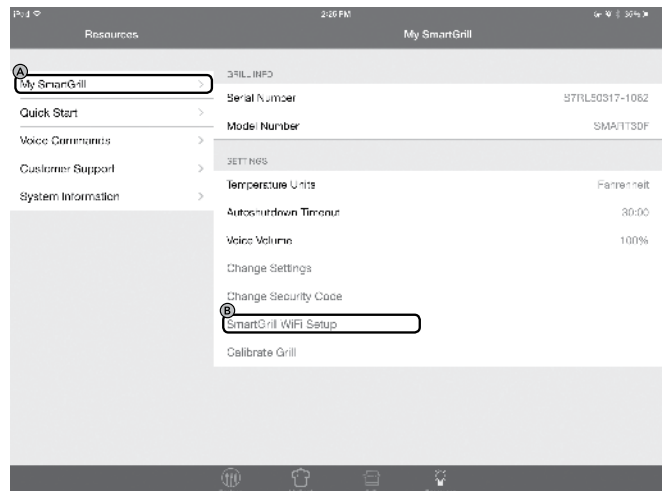

\*For the most current version of the Quick Start Guide, please refer to your app or our website at [www.lynxgrills.com](http://www.lynxgrills.com).

---

## QUICK START POWER CONNECTIVITY & WI-FI SET UP PROCESS...*(continued)*

---

E. Click on the SSID and enter the password for your home network (information in STEP #1—REQUIREMENTS) then select **DONE**. After 20-60 seconds, your SmartGrill will say "SmartGrill is connected to the internet" and your wireless configuration is complete. Now just power the SmartGrill off, then back on. SmartGrill will say "SmartGrill is connected to the internet" followed by "SmartGrill at your service." On the SmartGrill app click on the Grill icon and now your SmartGrill is connected and ready to grill.

### STEP #5—SETUP YOUR SMARTGRILL

- Turn your lights on by saying, "**SmartGrill Lights**". To turn the lights off, say "**SmartGrill, Lights**" and the lights will now turn off.
- To try out a recipe, go back to your SmartGrill App and go to the Recipe icon.
- Select a recipe from the recipe list and click Cook Now to send the recipe to your SmartGrill. Follow the voice commands (how many burners, place food on grill, turn food over, remove food from grill). Please note that it could take several minutes for your SmartGrill to preheat and give you the command to place food on grill.

### STEP #6—CALIBRATING YOUR SMARTGRILL

Before your first grilling session, use your SmartGrill app to calibrate your SmartGrill by Lynx™. This will set a minimum flame level which is affected by ambient temperature, altitude, wind conditions and more. Calibration is required for optimum performance of your SmartGrill. The calibration process will take 15-20 minutes.

To perform a calibration, please close the hood of the grill, then:

- By Voice Command: "**SmartGrill, begin calibration.**"
- By App:
  - Go to Resources
  - Select My SmartGrill
  - Select Calibrate Grill
  - Select Automatic Calibration

SmartGrill will automatically shutdown when calibration is complete. It will say "Calibration complete" or send you the same message on your app. If the calibration fails, SmartGrill will say "Calibration failed" or send you the same message on your app.

**Need more help?** Please refer to your detailed instruction manual or call our customer support team at 888-289-5969 and choose the SmartGrill option #5.

# WARNINGS



## WARNING

- Never use dented, rusty or damaged propane cylinders. Never store additional or empty propane cylinders in the grill cabinet or in the vicinity of this or any other appliance. Do not store propane cylinders indoors or on their sides.
- Children should never be left alone or unattended in an area where a grill is located. Place your grill well away from areas where children play. Do not store items that may interest children in or around the grill, in the cart, or in the masonry enclosure.
- Never move the grill when hot. When in use, portions of the grill are hot enough to cause severe burns.
- Always maintain the required clearances from combustibles as detailed. The grill is designed for outdoor use only. Never use in a garage, building, shed, breezeway, or other enclosed area. Do not use this grill under any unprotected combustible construction.
- Gas grills are not designed or certified for and are not to be installed in or on recreational vehicles, portable trailers, boats or any other moving installation.
- Always have an ABC Fire Extinguisher accessible — never attempt to extinguish a grease fire with water or other liquids.
- Storing your grill: Store your grill in a well-ventilated area. If stored indoors, detach and leave L.P. cylinder outdoors in a well-ventilated area away from heat and away from where children may tamper with it.
- Keep any electrical supply cord and the fuel supply hose away from any heated surfaces. Electrical cords should be placed away from walkways to avoid tripping hazard.
- Do not repair or replace any part of the grill unless specifically recommended in this manual. Other service should be performed by a qualified technician.
- If the grill is installed by a professional installer or technician, be sure that he/she shows you where your gas supply shut-off is located. All gas lines must have a shut-off that is readily and easily accessible. If you smell gas, check for gas leaks immediately. Check only with a soap and water solution. (See INDEX: “Leak Testing” for further details.) Never check for gas leaks with an open flame.
- Inspect the liquid propane gas supply hose prior to each use of the grill. If there is evidence of excessive abrasion or wear, or if the hose is cut, it must be replaced before using the grill.
- Never remove the grounding prong from the plug or use this product with an ungrounded, 2-prong adapter.
- Keep your grill area clear and free of combustible materials, gasoline and other flammable vapors and liquids.
- Never block the flow of combustion and ventilation air.

**THIS MANUAL MUST REMAIN WITH THE PRODUCT OWNER FOR FUTURE REFERENCE.**

This product complies with ANSI standard Z21.58/CSA 1.6 latest edition and has been tested and approved by Intertek.



To obtain replacement parts or service contact:

**Lynx Grills**  
**7300 Flores Street**  
**Downey, CA 90242**  
**888-289-5969**  
**[www.lynxgrills.com](http://www.lynxgrills.com)**

# TABLE OF CONTENTS

<b>QUICK START POWER CONNECTIVITY &amp; Wi-Fi SETUP</b>	<b>3</b>
<b>A MESSAGE FROM LYNX</b>	<b>7</b>
<b>USE &amp; CARE GUIDELINES</b>	<b>7</b>
<b>SMARTGRILL BY LYNX™ MODELS</b>	<b>7</b>
<b>IMPORTANT SAFETY PRECAUTIONS</b>	<b>8</b>
<b>GRILLING IN WINDY CONDITIONS</b>	<b>9</b>
<b>BEFORE YOU START</b>	<b>10</b>
If Shipment Arrives Damaged	10
Important Notes	10
<b>UNPACKING &amp; ASSEMBLY</b>	<b>10</b>
<b>SPECIFICATIONS &amp; INSTALLATION</b>	<b>12</b>
Clearance to Combustibles	11
<b>GAS CONNECTIONS</b>	<b>15</b>
Natural Gas	15
Liquid Propane	16
<b>ELECTRICAL CONNECTIONS</b>	<b>18</b>
<b>FINAL CHECKS</b>	<b>19</b>
Leak Testing	19
<b>GETTING STARTED</b>	<b>20</b>
Meet Your SmartGrill by Lynx™	20
Plugging In Your SmartGrill by Lynx™	20
Turning On Your SmartGrill by Lynx™	20
Connecting Your SmartGrill by Lynx™ to Your Wireless Network	21
Downloading Your SmartGrill by Lynx™ App for iOS Devices	21
Downloading Your SmartGrill by Lynx™ App for Android Devices	21
<b>SMARTGRILL BY LYNX™ SAFETY SYSTEMS</b>	<b>22</b>
Security Code Lock	22
<b>PRE-GRILL CHECKLIST</b>	<b>22</b>
How to Light Your SmartGrill by Lynx™	23
<b>BASIC OPERATIONS</b>	<b>23</b>
Listen Mode	23
Manual Mode	24
Timed Cook	24
Recipe Mode	24
Meal Mode	24
Party Mode	25
<b>VOICE COMMANDS</b>	<b>25</b>
<b>USING YOUR SMARTGRILL BY LYNX™ RECIPE DATABASE</b>	<b>26</b>
<b>ADVANCED OPERATIONS</b>	<b>28</b>
<b>CLEANING YOUR SMARTGRILL BY LYNX™</b>	<b>28</b>
<b>TROUBLESHOOTING SMARTGRILL BY LYNX™</b>	<b>30</b>
<b>OBTAINING SERVICE FROM LYNX</b>	<b>34</b>
<b>SMARTGRILL BY LYNX™ LIMITED WARRANTY</b>	<b>35</b>
<b>MODEL-SPECIFIC BTU OUTPUTS &amp; MAX. RUNS FOR APPLIANCES</b>	<b>38</b>
<b>INDEX</b>	<b>39</b>

---

## A MESSAGE FROM LYNX

---

Thank you for your purchase of a SmartGrill by Lynx™. You've just entered the future of grilling, a world of amateur and professional chefs who are taking the world of outdoor cooking to new levels through technology.

Your SmartGrill by Lynx™ has been designed to the same exacting standards and meticulous attention to detail every Lynx product enjoys. Beyond that though, you're about to enjoy a high-performance stainless steel grill that incorporates patented MyChef™ technology, an interactive, innovative and chef-friendly system designed to elevate your cooking to new heights.

To get the maximum performance out of your grill, we recommend carefully reading through this entire manual before your first cookout. It contains important information on how to properly set up your SmartGrill by Lynx™ and utilize the MyChef™ technology along with important safety tips and hints and tricks that will enhance your grilling experience. Keep it handy for easy reference and should your Lynx SmartGrill by Lynx™ change ownership, please make sure the new owner receives this manual. With proper use and care, your Lynx SmartGrill by Lynx™ will provide years of trouble-free service.

Thank you again for joining the community of Lynx chefs. We love hearing about your experiences with our products. Please check us out on the Web and social media to let us know how you and your SmartGrill by Lynx™ are doing.

Web: <http://www.lynxgrills.com/>

Facebook: <https://www.facebook.com/LynxProfessionalGrills>

Twitter: @LynxGrills

We wish you many years of happy grilling!

LYNX GRILLS



---

## USE & CARE GUIDELINES

---

This use & care manual covers the Lynx grill models listed below. Some features and options will vary based upon the model that you purchased.

---

### SMARTGRILL BY LYNX™ MODELS

---

BUILT-IN	FREESTANDING
SMART30	SMART30F
SMART36	SMART36F
SMART42	SMART42F

## WARNINGS



### WARNING

1. Do not open the central electronics container as there are no user-serviceable parts inside, and doing so will void all warranties. All other services should be performed by a qualified technician.
2. All gas lines must have a gas shut-off valve that is readily and easily accessible. Be sure you know where the shut-off is located. If you smell gas, check for gas leaks immediately. Check only with a soap and water solution. Never check for gas leaks with an open flame. (See INDEX: "Leak Testing" for further details)



### WARNING

1. The outdoor cooking gas appliance and its individual shutoff valve must be disconnected from the gas supply piping system during any pressure testing of that system at test pressures in excess of 0.5 psi (3.5 kPa).
2. The outdoor cooking gas appliance must be isolated from the gas supply piping system by closing its individual manual shutoff valve during any pressure testing of the gas supply piping system at test pressures equal to or less than 1/2 psi (3.5 kPa).



### STATE OF MASSACHUSETTS

1. Massachusetts requires all gas be installed using a plumber or gas fitter carrying the appropriate Massachusetts license.
2. All permanently-installed natural gas or propane installations require a "T" handle type manual gas valve be installed in the gas supply line to this appliance.
3. This does not apply to portable propane installations using a 20 pound cylinder.

## IMPORTANT SAFETY PRECAUTIONS

### PLEASE REVIEW THESE IMPORTANT SAFETY PRECAUTIONS BEFORE YOU USE YOUR GRILL.

1. NEVER LEAVE THE GRILL UNATTENDED WHILE COOKING.
2. Ensure all tie-down wires have been removed from the burners.
3. Always use caution when operating the grill in a windy area. (See INDEX: "Grilling in Windy Conditions" for further details.)
4. Avoid wearing loose-fitting garments or long sleeves while grilling. They could ignite.
5. Never touch the grill racks, hood or immediate surrounding metal surfaces with your bare hands while grilling.
6. Use an insulated glove or mitt when opening and operating the grill. Always open the grill lid slowly to allow heat and smoke to escape before fully opening.
7. The grill hood must be fully opened while lighting the grill. Releasing fuel into a closed grill before lighting will not make it light sooner or more efficiently. It will only risk explosion and personal injury or death. Never lean over a hot grill surface or look directly into the grill when attempting to light.



## IMPORTANT SAFETY PRECAUTIONS...(continued)

- Do not heat unopened food containers as pressure build-up will cause the container to explode.
- Do not use aluminum foil to line grill racks or drip pans. This will alter the airflow or trap excessive heat in the control area and can melt control knobs and ignition modules. Such damage is specifically excluded from your warranty.
- Never use charcoal or any other solid fuel in the grill.
- Cooking excessively fatty meats and oils will cause flare ups. Internal fires or damage caused by doing so or by the grill being left unattended while cooking are not covered under the terms and conditions of our warranty.
- Never grill without the drip pan in place. Always ensure the drip pan is pushed all the way to the back of the grill. Hot grease can leak downward and produce a fire or explosion.
- Grease is extremely flammable. Let hot grease cool down before attempting to handle or dispose of it. The drip tray and bottom of the firebox should be cleaned of grease on a regular basis.
- Do not use the grill unless a leak check has been performed on all gas connections. (See INDEX: "Leak Test Procedure" for further details.)
- Never operate the grill while under the influence of alcohol or drugs.
- Do not lean on side shelves and never place a load weighing more than 25 pounds on a side shelf.
- If any burner does not light or goes out during operation, turn off all gas control knobs, open the hood and wait five (5) minutes before attempting to re-light.
- Portable LP cylinders: Always shut off the main valve on the LP cylinder after each use.
- Spiders and insects like to nest in the burners, venturis, valves and orifices of a grill, disrupting the gas flow. This very dangerous condition can cause a fire behind the control panel, damaging the grill and risking personal injury. If your grill has been unused for a long time, inspect and clean the burners, venturis, valves and orifices. (See INDEX: "Cleaning your Lynx Grill" for further details.)

## GRILLING IN WINDY CONDITIONS

Outdoor grills create more heat than interior kitchen ranges. That's how they sear and grill steaks and other foods.

These high-performance burners require a constant, steady supply of fresh air to mix with the fuel. Your Lynx grill pulls air in through the front and vents hot gases out through the rear.



Air enters through the front of the grill.

Using your grill in windy conditions may disrupt the front-to-back air flow. If, while grilling with all burners on high and the hood closed, you notice that the temperature gauge fails to rise ... be careful. If wind has kept hot gases from exiting the rear of the grill the control panel and knobs may have become extremely hot.



Wind hitting the back of the grill can disrupt proper exhaust.

Your Lynx grill features an exclusive, patent-pending Heat Stabilizer that will deflect wind and, in most cases, prevent this situation.

But there are a few things you can do to further **prevent the possibility of improper heat buildup**:

- On breezy days, be careful not to leave the front hood down for more than 15 minutes when the burners are on high. (Never leave the grill unattended when in operation)
- If you suspect the grill is overheating, using an oven mitt, open the front hood. Then adjust the burner control knob to a lower setting.
- Install your grill with a wind break behind it.
- Orient the grill so prevailing winds are not blowing into the rear of the grill.

**Please Note: Any damage caused from use in windy conditions, such as melted knobs or igniter wires, or control panel discoloration from heat buildup, is excluded from warranty coverage.**

## BEFORE YOU START



### WARNING

- Never install this product into a combustible enclosure without an insulated jacket. Doing so could result in fire, property damage and personal injury.
- Never locate the grill under an unprotected roof or overhang, in a building, garage, shed or other such enclosed area.
- Never locate the grill under unprotected combustible construction.
- Installation must conform with local codes or, in the absence of local codes, with either the National Fuel Gas Code, AN-SIZ223.1/NFPA 54, Natural gas and Propane Installation Code, CSA B149.1, or Propane Storage and Handling Code, B149.2, in Canada.

## IF SHIPMENT ARRIVES DAMAGED

### VISIBLE LOSS OR DAMAGE

Be certain any visible damage to the carton is noted on freight bill or express receipt and signed by the person making delivery.

FILE CLAIM FOR DAMAGES IMMEDIATELY, regardless of extent of damage.

### CONCEALED LOSS OR DAMAGE

If damage is unnoticed until the grill is unpacked, notify the transportation company or carrier immediately and file a "concealed damage" claim with them. This should be done within (15) days of the date delivery is made to you. Be sure to hold on to the container for inspection. We cannot assume responsibility for damage or loss incurred in transit. (See Page 32: "Obtaining Service from Lynx" for further details.)

Shipping receipts should be signed "not inspected for concealed damage" if you did not open and inspect the product before the delivery driver leaves.

### DAMAGE TO ELECTRONICS CONTAINMENT BOX

Should your electronics containment box be damaged during shipment, please contact Lynx Customer Care immediately. **Under no circumstances should you open**

**the electronics containment box. There are no user serviceable parts inside and doing so will void all warranties.**

## UNPACKING & ASSEMBLY

The grill arrives nearly ready to use and requires only minor assembly.

By carefully following the uncrating and unpacking steps, you'll be up and grilling on your Lynx SmartGrill by Lynx™ in no time!

Shipping weight on smaller units is app. 300 pounds and larger units may weigh over 500 pounds.



### WARNING: EXCESSIVE WEIGHT HAZARD!

Use two or more people to move or install this unit. Failure to follow this instruction can result in back or other personal injuries as well as potential damage to your SmartGrill by Lynx™.

## CRATE & CARTON

- **IMPORTANT!** Do not remove staples around the top of the carton. These staples hold a wooden pallet in place inside the carton that protects the unit from damage. Removing these staples may cause the pallet to fall on top of the grill and damage the internal mechanisms that power the SmartGrill by Lynx™'s computer core.

### How to Remove the Carton

- Cut the main strap holding the grill to the pallet.
- Remove the staples at the bottom of the carton.
- Lift off the carton.
- With assistance, remove the grill from the pallet and place into desired location.



Grill will not slide directly off pallet.

The wheels sit down in the gaps of the shipping crate so that the grill can sit safely and solidly on the crate during shipping. The grill cannot be slid directly off of the pallet.

## BEFORE YOU START...(continued)

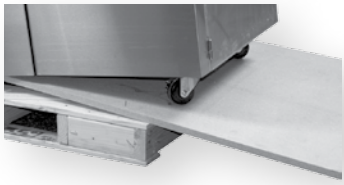

One way to safely move the grill off of the pallet is by lifting one end of the grill high enough to place a ramp under the wheel and then lift the other end while rolling the grill off of the pallet.

### INTERIOR PACKING

Lynx uses sturdy tie-down cables and straps to ensure your grill arrives at your home in the same condition that it left our factory. **BE SURE YOU HAVE REMOVED ALL TIE DOWNS BEFORE USING YOUR GRILL.**

Make sure you remember to remove the tie-downs on the burners.

- **Remove any loose items from the packaging, firebox, and drip tray.**
- Ensure that all burners are properly seated on the burner valve orifice and sitting level with the crossbar firmly locked in front of the back bracket.

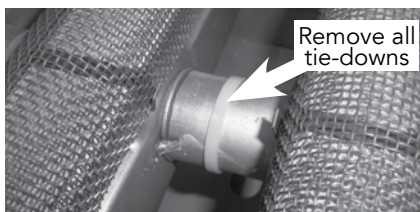

### BUILT-IN INSTALLATIONS

The SmartGrill by Lynx™ built-in grill is designed for easy installation into masonry enclosures.

NOTE: Lynx built-in SmartGrills are intended either for installation in a built-in enclosure constructed of non-combustible material or for an installation to a built-in enclosure constructed of combustible material when installed with a Lynx Insulating Jacket (LIJ)

For non-combustible applications, the grill drops into the opening shown in the cutout detail drawing (See Page 12: "Gas Connections") and hangs from its counter-top trim. A deck is not required to support it from the bottom.

When using the insulated jacket in a combustible enclosure, the jacket must be supported from the bottom by a ledge

on each side or a full deck beneath the jacket.

Pay special attention to the provisions shown for gas-line hookup.

The enclosure should have ventilation holes to prevent gas build-up in the event of a leak. The deck ledges and counter should be flat and level. (refer to ANSI z21.58 Standard for Outdoor Cooking Gas Appliances, Section 1.7 Enclosures For Self-Contained LP-Gas Supply Systems). Keep the ventilation openings of the cylinder enclosure free and clear from debris.

This grill requires that a 120-volt, 60 hertz, 15 amp GFI-certified outlet be installed by a qualified electrician.

### CLEARANCE TO NON-COMBUSTIBLE MATERIALS

Non-combustible materials may make direct contact with the edges of the firebox body up to the top surface of the firebox. Below the counter top surface the non-combustibles should not encroach on the cutout dimensions defined in this manual for both fit, access to service and airflow.

Above the counter top a minimum clearance of 6" is needed on the left side of the grill for the motor and skewer if you have a rotisserie model grill. At least 6" of clearance on the right side is recommended as well.

A 3 inch clearance is required immediately behind the grill to allow the front hood to open. The grill exhausts combustion products and cooking greases to the back of the unit. Never locate the grill where this residue will be difficult to clean.

Any non-combustible overhead surfaces must be at least 6 feet above the counter top surface. A vent hood may be closer to the counter top surface than 6 feet.

### CLEARANCE TO COMBUSTIBLE MATERIALS

Minimum clearance from the sides and back of the grill to adjacent combustible construction below the counter top surface is 12" from the sides and back.

***Dégagement minimal entre les parois latérales et l'arrière de l'appareil et la construction combustible au-dessous du panneau supérieur de l'appareil (30 cm à partir des parois latérales et 30 cm à partir de l'arrière).***

Minimum clearance from sides and back of grill to adjacent combustible construction extending above the counter top surface is 18" from the sides and back.

## BEFORE YOU START...(continued)

**Dégagement horizontal minimal entre les parois latérales et l'arrière de l'appareil et la construction verticale combustible au-dessus de l'appareil (45.7 cm à partir des parois latérales et 45.7 cm à partir de l'arrière).**

Do not use this appliance under unprotected overhead combustible surfaces.

**Ne pas utiliser cet appareil en-dessous de surfaces combustibles non protégées.**

**If the grill is to be placed into a combustible enclosure, an approved insulated jacket is necessary and is available only from Lynx or your Lynx dealer. Lynx insulated jackets have been designed and tested specifically for your Grill.**

### OVERHEAD PROTECTION AND EXHAUST REMOVAL

If the grill is installed under any combustible construction the cooking area over the grill must be covered with an outdoor approved exhaust hood. The hood must provide 3 to 6 inches of overhang on all exposed sides. The bottom of the hood should be positioned at least 36 inches above the counter top surface. The exhaust hood shall provide no less than 1200 CFM for proper exhaust ventilation and it must be provided with a dedicated GFCI protected branch circuit.

### REAR HOOD CLEARANCE

A 3 inch clearance is required behind the grill to provide unobstructed opening of the hood.

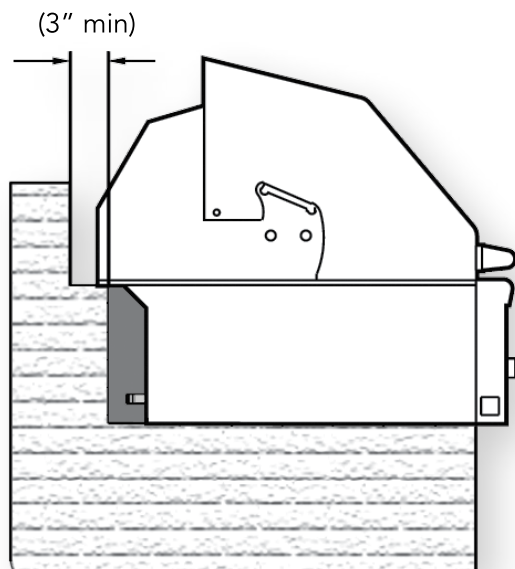

The grill exhausts combustion products and cooking greases to the back. Never locate the grill where this exhaust will be difficult to clean.

### SPECIFICATIONS AND INSTALLATION

The guides, measurements and dimensions detailed below are designed to assist you with planning your outdoor kitchen.

NOTE: Due to continuing product innovation, specifications are subject to change without notice.

IMPORTANT: Please reference the Care & Use/Installation manual for details on gas plumbing requirements, electrical specifications and the proper installation of your Lynx outdoor kitchen equipment. This manual can be downloaded from the Lynx Web site at [www.lynxgrills.com](http://www.lynxgrills.com).

### IMPORTANT INSTALLATION NOTES

#### HOW LONG IS YOUR RUN?

Keep all gas supply lines as short as possible. Gas lines lose pressure over distance and with each elbow and tee that is added. This drop in pressure affects the grill's performance. (See INDEX: "Gas Supply Line Runs" for further details.)

#### BE SURE YOUR GRILL IS LEVEL

Proper levelling during installation is critical to the smooth operation of your SmartGrill by Lynx™. A grill that is out of level will cause erratic burner combustion and inefficient, uneven heating. A carpenter's spirit level should be used to level the grill both front-to-back and side-to-side.

If the floor is uneven or has a pronounced slope, re-leveling may be required each time you move a freestanding SmartGrill by Lynx™.

# CUTOUT SPECIFICATIONS

The guides, measurements and dimensions detailed below are designated to assist you with planning your outdoor kitchen.

**NOTE:** Due to continuing product innovation, specifications are subject to change without notice.

**IMPORTANT:** Please reference the Care & Use / Installation manual for details on gas plumbing requirements, electrical specifications and the proper installation of your Lynx outdoor kitchen equipment. This manual can be downloaded from the Lynx website at [www.lynxgrills.com](http://www.lynxgrills.com)

## GRILLS

MODEL	A	B	C
L27	26.00	10.88	22.00
<b>L30SMART</b>	29.00	10.88	24.50
<b>L36SMART</b>	35.00	10.13	22.00
L42, <b>L42SMART</b>	41.00	10.88	24.50
L54	53.00	10.88	24.50
LPZA	29.00	5.25	24.50

## COMPLEMENTARY PRODUCTS

### ACCESS DOORS

MODEL	A	B
LDR24L, LDR24R	19.25	19.00
LDR30T	28.25	19.00
LDR36T	31.63	19.00
LDR42T	37.63	19.00

### SIDE BURNERS

MODEL	A	B	C
LSB1-3	12.13	10.63	12.50
LSB2-2	12.13	10.63	24.50
LSB2PC-1	24.25	10.63	24.50
LPB	19.00	10.63	22.00

### UTILITY DRAWERS

MODEL	A	B	C
LUDE	12.13	19.25	24.00
LUDXL	17.25	18.57	24.25
LDW16	14.59	19.00	24.50
LDW19	17.50	19.00	24.50
LMD	21.75	5.63	23.38

### WARMING DRAWERS

MODEL	A	B	C
L30WD-1	28.50	10.00	20.50
L42CC-1	40.25	19.38	24.50

### COCKTAIL PRO

MODEL	A	B	C
CS30-1	29.00	10.63	22.75

## WITH INSULATED JACKET INSTALLED

MODEL	A	B	C
LIJ27	33.00	11.63	24.00
LIJ30	36.00	11.63	26.50
LIJ36	42.00	11.63	24.00
LIJ42	48.00	11.63	26.50
LIJ54	60.00	11.63	26.50

## STORAGE SYSTEMS

MODEL	A	B	C
LSA30	28.25	19.00	24.50
LSA36	34.25	19.00	24.50

## TRASH CENTERS

MODEL	A	B	C
L18TC	16.00	24.00	13.00
L20TR	16.81	24.00	24.75
LTA530	28.25	19.00	20.00

## SINKS AND DROP IN COOLER

MODEL	A	B	C
LSK18	17.00	10.50	22.00
LSK24	23.00	10.50	22.00
LSK30	29.00	10.50	22.00
LDC18	18.25	13.00	18.25

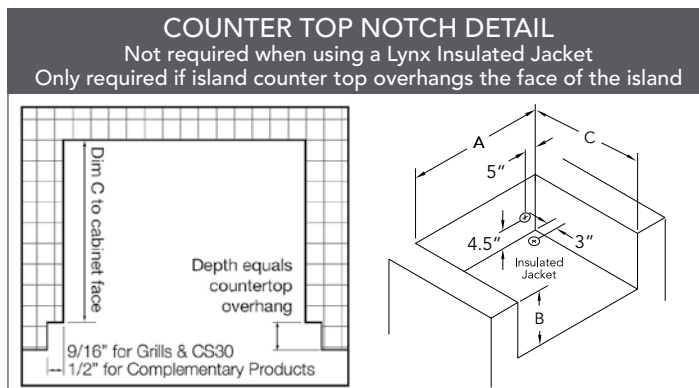
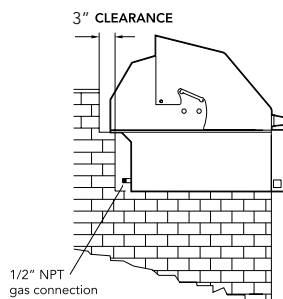

# SPECIFICATIONS & INSTALLATION

## OUTDOOR REFRIGERATORS

MODEL	A	B	C	D
L24REF	24.25	33.00	26.00	32.00
L24BF	24.25	34.50	26.00	34.25
L24DWR	24.25	34.50	26.00	34.25
L15ICE	15.25	34.50	26.00	33.50
L15WINE	15.25	35.50	26.00	34.375

## ICE MACHINE

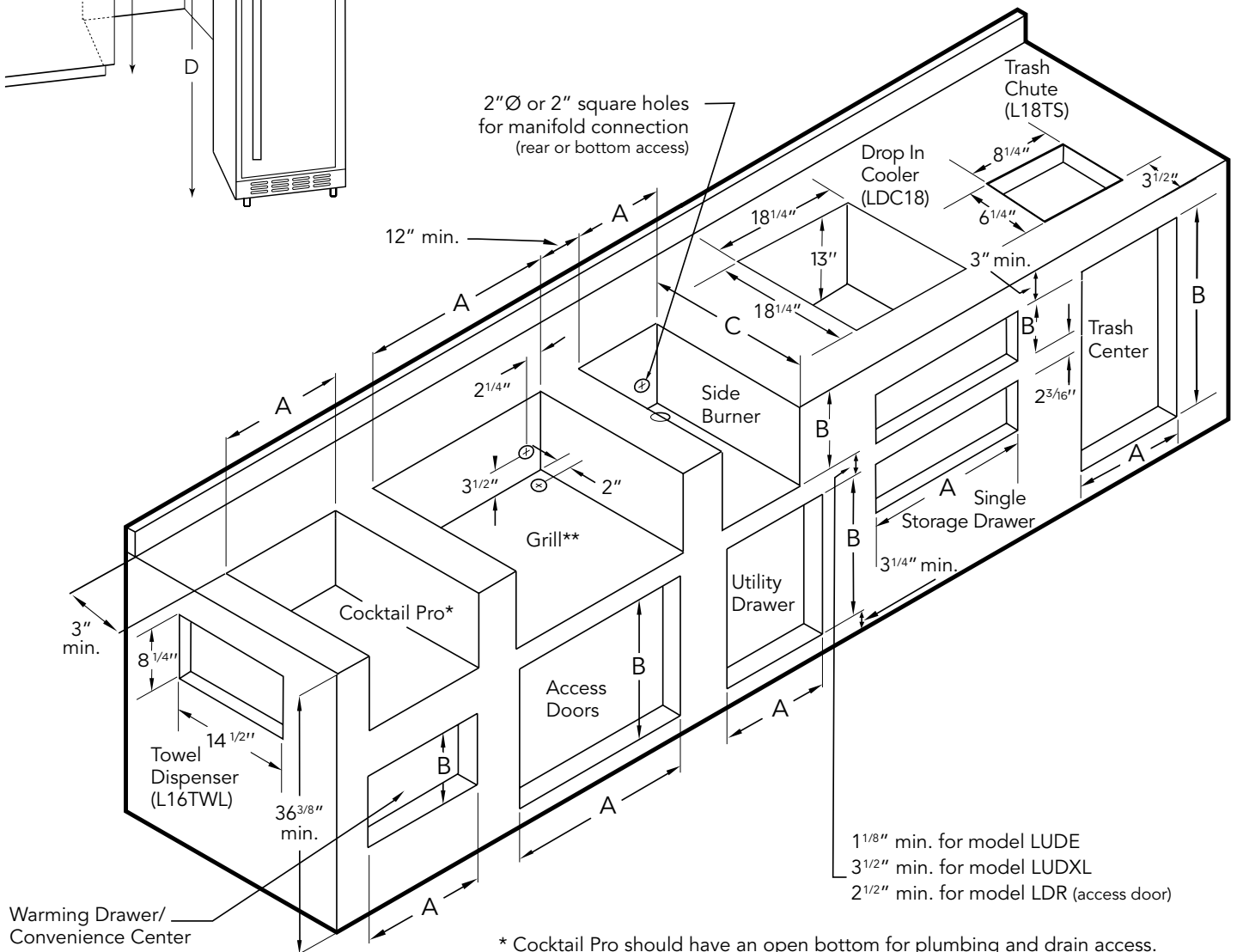
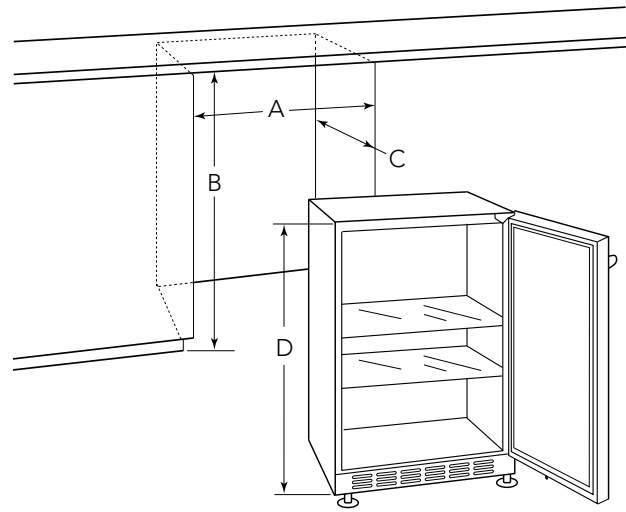
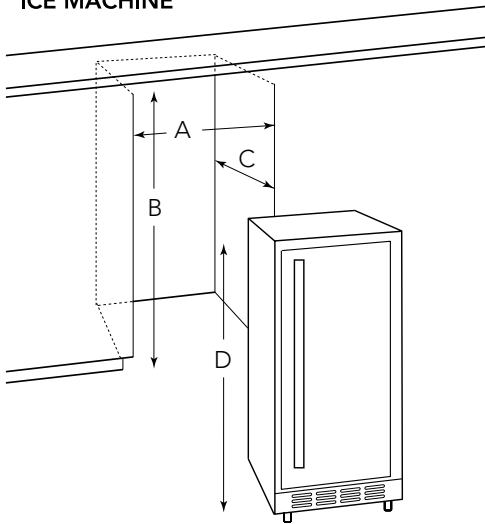

\* Cocktail Pro should have an open bottom for plumbing and drain access.  
 \*\* 1" square hole must be located at rear of grill cutout. 120V GFI outlet must be located within 6' of the 1" hole.

# GAS CONNECTIONS



## WARNING

NEVER CONNECT A GAS LINE DIRECTLY TO THE SMARTGRILL BY LYNX™. A PRESSURE REGULATOR MUST BE INSTALLED ON ALL GAS EQUIPMENT. ALL LOCAL CODES REQUIRE IT AND LYNX GRILLS SUPPLIES THE CORRECT REGULATOR FOR USE WITH YOUR GRILL. REMOVING OR FAILING TO INSTALL THE PRESSURE REGULATOR CAN RESULT IN FIRE AND SERIOUS PERSONAL INJURY AND WILL VOID THE WARRANTY.

**The SmartGrill by Lynx™ is factory set to use either liquid propane or natural gas. It is critical that the gas you use matches that for which the grill was set up. You can verify this by checking the rating plate.**



The rating plate lists serial numbers, model numbers and gas type and is located in one or more of the following places:

- Attached to the underside of the drip tray
- On the back of the Care & Use manual
- On the PC case

Ensure that the gas supplied meets with the minimum pressure requirements. Do not operate the grill with any gas other than that for which the grill has been set.

### Water Column Requirements

Fuel	WC Max Inlet	WC Min Under Full Load
Nat Gas	7 in	4 in
LP	14 in	11 in

Both the regulator and the manifold orifices have been tuned for the type of gas specified on the rating plate.

## GAS CONVERSION KITS

Gas conversion kits are available from Lynx grills to allow the SmartGrill by Lynx™ to operate on either natural gas or liquid propane gas. These kits should be installed by a qualified technician.

The kits come with complete installation instructions. These instructions should be read completely and fully.

All installation and all installation parts must conform to local codes with the National Electrical Code, ANSI Z223.1/NFPA 70 latest edition and the National Fuel Gas Code, ANSI Z223.1/NFPA 54 in the U.S. and CGA-B149.1/.2 in Canada.

Canadian installations must conform to CGA-B149.1/.2 natural gas/propane installation code. (Canada)

## NATURAL GAS

Lynx Grills recommends that only qualified professionals perform the required plumbing on this product.

To ensure satisfactory performance, the gas supply line must be sized to accommodate the total BTU requirements of all the gas-fired equipment that will be connected to that line.

In no case should pipe less than 3/4" inside diameter or 1" outside diameter ever be used to connect this product.

- Calculate the total BTU output of all equipment and refer to "INDEX: Gas Supply Line Runs" for allowable run distances for 3/4 inch pipe. Failure to meet these minimum requirements may reduce performance of the grill and any other appliances running on that supply line.
- Always keep supply line runs as short as possible. (See INDEX: "BTU Output" for specific model outputs)
- A gas shut-off valve must be installed in an easily accessible location by a qualified plumber.
- Keep threading compound off of the first two pipe threads to avoid having any small pieces of compound break loose and clog a burner valve or orifice. Do not use threading compound on any flare fittings.

For built-in installations, it is recommended that any flexible pipe used be kept as short as possible. (See INDEX: "Gas Connections" for typical permanent hook up.)

Keep last two threads clean

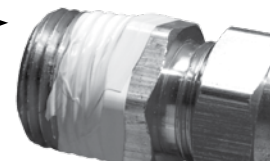

For freestanding units using natural gas or hard piped LP gas, Lynx strongly recommends using a quick disconnect kit.

This Quick Disconnect Kit (part #LQD) is available from Lynx or your dealer.

## GAS CONNECTIONS ...continued

### LIQUID PROPANE GAS

Grills set up for liquid propane gas come equipped with a liquid propane hose/ regulator assembly for connection to a standard 20 lb. Liquid propane cylinder (Type 1). All fittings necessary to attach the assembly to the grill are included.



LP cylinder with type 1 valve connection

Permanently plumbed liquid propane connections, such as those in line with a bulk cylinder, require a 4/11 regulator. (Lynx P/N 30781)

When using the 4/11 regulator, you must ensure that it is set for the proper fuel type. This is done by removing the regulator cap and gasket and looking at the bottom of the plunger to see what fuel type is visible. This is the regulator fuel setting. NAT is for natural gas and LP is for propane gas. The LP setting can be further identified by the large diameter disk on the bottom of the plunger. To change from one gas to the other, simply push the plunger to the side to snap it out of the cap, turn the plunger so it reads the desired gas type on the bottom, and push the plunger until it snaps back into place in the cap and then replace the cap into the regulator.

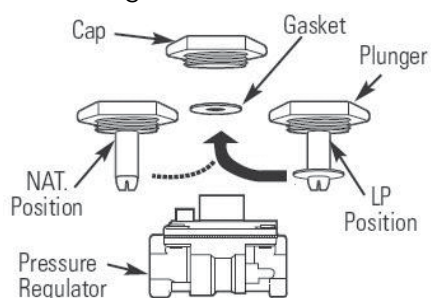

**NEVER CONNECT AN UNREGULATED GAS LINE TO THE GRILL.**

#### Liquid Propane Cylinder Requirements

The LP cylinder must be constructed and marked in accordance with the specifications for LP gas cylinders of the U.S. Department of Transportation (DOT) and designed for use with a Type 1 system only.

Cylinders of free standing grills must be secured using the provided cylinder retention system to avoid accidental movement. Make sure the hose between the grill and the

### WARNING

Do not change the regulator/hose assembly or use any other assembly than the one supplied with your Lynx SmartGrill by Lynx™.

Do not attempt to use a 5LP-A equipped regulator/hose assembly with a standard 510 POL cylinder/valve assembly.

Do not store a spare LP-gas cylinder under or near this appliance.

Never fill the cylinder beyond 80 percent full.

If the information above is not followed exactly, a fire causing death or serious injury may occur.

propane bottle does not touch the back or bottom of the firebox.

When exchanging your cylinder for a refill, exchange only for a Type 1 20lb cylinder with an over-fill protection device.

Never use a cylinder with a damaged valve.

A dented or rusty LP cylinder may be hazardous and should be avoided. If in doubt, have it checked by your liquid propane supplier.

Always check for leaks after every liquid propane cylinder change. (See INDEX: "Leak Test" for further details.)

Always shut off the liquid propane gas supply at the cylinder when the SmartGrill is not in use.

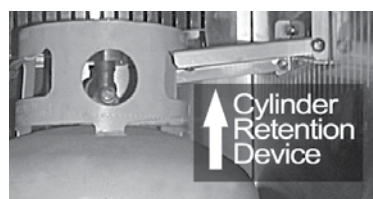

Cylinders must be stored outdoors in a well-ventilated area out of the reach of children. If your

grill is stored indoors, the liquid propane cylinder must be stored outside.

#### Liquid Propane Connections

Make sure the liquid propane cylinder valve is completely closed. It is possible for the valve to be opened without releasing gas, but as soon as you start connecting the regulator, gas can flow from the connection.

Insert the regulator inlet into the cylinder valve and turn the black coupler clockwise until the coupler is hand tight. Do not over-tighten this connection.

To disconnect the coupler, first make sure the main cylinder valve is turned off. Grasp the coupler and turn counter-clockwise. The inlet will then disengage.



## GAS CONNECTIONS ...continued

Always leak test the connection after refilling or exchanging liquid propane cylinders. (See INDEX: "Leak Test" for further details.)

### TO CONNECT A BUILT-IN SIDE BURNER

- Shut off the gas supply at the main valve.
- Disconnect all plumbing (if already attached) from the grill and the gas supply valve.
- Remove all the fittings from the grill manifold.
- Install the side burner into the counter top cutout.
- Connect the gas supply to the grill and side burner as shown in the two diagrams on this page.
- Turn the gas supply on and leak test all connections. (See INDEX: "Leak Test" for further details.)

NOTE: The side burner will function manually only and is not connected to the SmartGrill by Lynx™ Wi-Fi.

### FOR INSTALLING A SIDE BURNER ONTO A FREESTANDING SMARTGRILL

- Shut off the gas supply at the main valve.
- Disconnect all plumbing (if already attached) from the grill and the gas supply valve.
- Remove all the fittings from the grill manifold.
- Install the side burner onto the cart according to the directions supplied with the cart mounting kit.
- Connect the gas supply to the grill and the side burner as shown in the diagrams on this page for your gas type.
- Turn the gas supply on and leak test all connections. (See INDEX: "Leak Test" for further details.)

NOTE: The side burner will function manually only and is not connected to the SmartGrill by Lynx™ Wi-Fi.

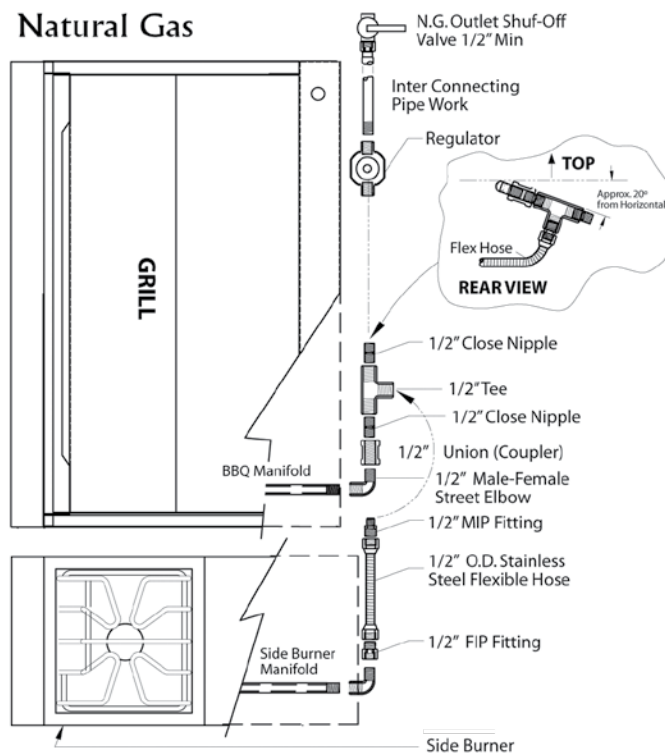
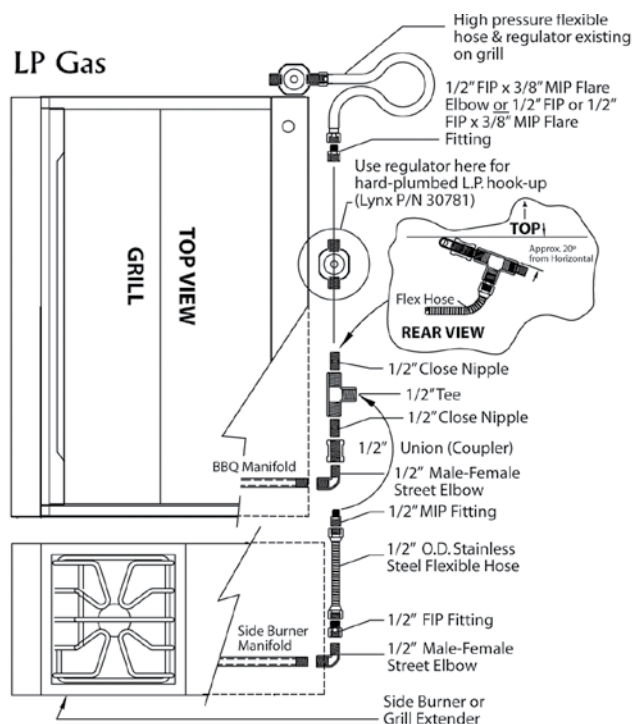

# ELECTRICAL CONNECTIONS



## WARNING: ELECTRICAL GROUNDING

- Product installation must meet local electrical codes, or in the absence of local codes, the latest edition of the National Electrical Code ANSI/NFPA No. 70 or the Canadian Electrical Code CSA C22.1.
- Use only a Ground Fault Interrupter (GFI) protected circuit with this outdoor cooking gas appliance.
- Do not use this outdoor cooking appliance if it has been submerged underwater without a thorough inspection by a qualified technician.
- This grill is equipped with a three-prong (grounded) electric plug for your protection against shock hazard and must be plugged directly into a properly grounded three-prong outlet. Never cut or remove the grounding prong from this plug.
- Use only extension cords with a three-prong grounding plug, rated for the power of the equipment and approved for outdoor use with a "W-A" marking.
- To protect against electric shock, do not immerse any part of the power cord, an extension cord, or any plugs in water or other liquid.
- Unplug the product before thorough cleaning. Allow it to cool before putting on or taking off parts.
- Do not let the cord hang over the edge of a table or touch hot surfaces.
- Do not use an outdoor cooking gas appliance for purposes other than intended.
- Do not operate any outdoor cooking gas appliance with a damaged cord, plug, or after the appliance malfunctions or has been damaged in any manner. Contact Lynx for repair.

## CONNECTION TO AC POWER

Installation requires an outdoor 120VAC 15A GFI (Ground Fault Interrupter) electrical outlet adjacent to the SmartGrill by Lynx™.

The GFI outlet features an internal break that reduces shock hazard. This type of outlet should be installed by a qualified electrician either inside the island enclosure for built-in units, or near the location where a free standing unit will be used.

If the electrical system fails to operate, a connection may have come loose in shipping or the GFI may have tripped requiring a re-set. See the Troubleshooting section for more details.

A side burner or power burner can be connected to your SmartGrill with the wiring connection in the back of each unit. Ask your dealer or call Lynx at 888-289-5969 for more information.

# FINAL CHECKS

## LEAK TESTING



### DANGER!

To prevent fire or explosion hazard, DO NOT smoke or allow any potential source of ignition (sparks, electrical arcing, etc) in the area while performing a leak test. Leak tests should be conducted outdoors only. Never conduct a leak test using fire or flame.

### Leak Test Procedure:

- Create a soapy solution of 1 part soap and 3 parts water.
- Confirm that all control dials are in the off position.
- Turn on the fuel supply. For natural gas, turn the valve handle 1/4 turn to align with the gas flow.
- For L.P., turn the cylinder valve dial counter clockwise one full rotation.
- Apply the soap solution generously by paint brush or squirt bottle on all connections and fittings.
- If bubbles appear to “grow” on any of the connections, you have a gas leak. IMMEDIATELY turn off the gas supply.

### Fixing a Gas Leak:

- Shut off the gas supply
- Turn all grill controls to the “ON” position to purge the grill of any gas build-up, then turn the controls back “OFF”.
- Wash off the soapy solution with cold water and dry.
- Tighten the loose joint, or replace the faulty part with manufacturer-recommended replacement parts.
- DO NOT attempt to repair the L.P. cylinder valve if it is damaged. The only way to safely resolve a damaged cylinder is to REPLACE IT.
- Repeat the leak test to ensure that no leaks are present.

## FINAL CHECK

Finally, check all the burners for proper operation. Make sure the control knobs turn freely and completely through their full range.

### IMPORTANT:

**Make sure you know where the main gas supply shut-off valve is located.**

**Finally, for safety and for proper use and care, you must have this manual. Please keep it somewhere safe for future reference.**

For technical support and customer service, call:

Lynx Customer Care Department  
7300 Flores Street  
Downey, CA 90242  
Ph.: 562-299-6900  
Toll Free: 888-289-5969  
Fax: 562-299-6978

## GETTING STARTED

### MEET YOUR SMARTGRILL BY LYNX™

Congratulations on your purchase of a SmartGrill by Lynx™! You've joined a select group of cooking enthusiasts boldly paving the way toward a bright new grilling future.

The pages that follow will help you get the most out of your SmartGrill by Lynx™. Before that though, it's important to understand that the SmartGrill by Lynx™ has several basic requirements.

### THINGS TO KNOW ABOUT SMARTGRILL

1. The SmartGrill requires gas and electricity to operate.
2. The SmartGrill is powered by a PC. When turning the grill on, there will be a wait time while the grill boots up. Any time the grill is loading or booting, the knob LEDs will oscillate back and forth letting you know the grill is busy.
3. SmartGrill uses patented variable infrared burners. Doing an active cooking process, you will see the burners brighten and dim as the MyChef operating system regulates the cooking temperature. Do not be concerned, this is absolutely the intended function of SmartGrill.
4. The SmartGrill requires either a WiFi internet connection or a wired internet connection. To unlock the potential and power of your SmartGrill, we strongly recommend connecting your SmartGrill to your home internet connection.

### PLUGGING IN YOUR SMARTGRILL BY LYNX™

Your SmartGrill by Lynx™ comes with a power cord designed to fit into a 120 volt AC 15 amp GFI (Ground Fault Interrupter) electrical outlet.

**This power cord must be plugged in prior to any attempt to utilize the SmartGrill by Lynx™.**

**Each time you plug in your SmartGrill, wait 20-60 seconds to hear your SmartGrill say, "SmartGrill Ready."**

### TURNING ON YOUR SMARTGRILL BY LYNX™

Your SmartGrill by Lynx™ is activated by pressing the round POWER ON/OFF switch located on the left hand side of the grill.



### CONNECTING YOUR SMARTGRILL BY LYNX™ TO YOUR WIRELESS NETWORK

The first time you turn on your SmartGrill by Lynx™, the SmartGrill by Lynx™'s voice modulator will say "Please setup your Wi-Fi connection" followed by "SmartGrill, at your service."

Before you can connect your SmartGrill by Lynx™ to your wireless network, you must first download the SmartGrill by Lynx™ app to a compatible iOS or Android Device.

Be sure your SmartGrill by Lynx™ is plugged in and turned on before attempting to connect it to your wireless network.

In order to connect your SmartGrill by Lynx™ to your wireless network:

- Activate your iOS or Android phone or tablet
- Click on the "Settings" app
- In Settings, click on "Wi-Fi"
- You will see "SmartGrill" in the selections under "Choose a Network."
- Tap "SmartGrill" to connect to the SmartGrill by Lynx™ Wi-fi spot

## GETTING STARTED ...continued

- Shut down the Settings app
- Activate the SmartGrill by Lynx™ app

If this is the first time you've activated your SmartGrill by Lynx™ app, you will be asked to input the serial number then the PIN number for the CPU.

- The PIN and serial numbers assigned to each CPU and can be found on the PC case.
- Open the SmartGrill App and click Create Account then enter your grill serial number and PIN then click Continue.
- Enter your email address, password and your registration information and click Create Account. You will get a confirmation email.
- Open the confirmation email and follow instructions to activate your account.



- Once the app has been connected to the SmartGrill by Lynx™, the app will open up the "Grill Status" page. Click the light bulb labeled "Support" at the bottom of the screen.
- Click "Wi-Fi" settings
- You will see a list of networks available for your SmartGrill by Lynx™. Choose your home network.
- Depending on your security settings, you may need to enter your home network's password to allow the SmartGrill by Lynx™ access.
- Once the SmartGrill by Lynx™ has successfully accessed your home network, you will receive a "Success" message.

After you have successfully connected the SmartGrill by Lynx™ to your home network, you may have to return to your device's "Settings" app and reconnect with your home network.

### DOWNLOADING YOUR SMARTGRILL BY LYNX™ APP FOR IOS DEVICES

- Click the "App Store" icon on your iPhone or iPad
- Ensure that you have iOS 7.0 or above (check Settings>General>About>Version to see what version of iOS you're running.)
- In the Search box, type in "SmartGrill by Lynx" to find the app.
- Click to download and follow the guided instructions.

### DOWNLOADING YOUR SMARTGRILL BY LYNX™ APP FOR ANDROID DEVICES

- Click the "Google Play" icon on your Android phone or device. (This is typically under the Settings tab.)
- Ensure that you have Android 2.1 or above. (Check Settings>About Phone and look for "Android Version" or "Firmware Version.")
- In the Search box, type in "SmartGrill by Lynx" to find the app.
- Click to Download and follow the guided instructions.

# SMARTGRILL BY LYNX™ SAFETY SYSTEMS

Your SmartGrill by Lynx™ is designed with a number of safety systems that ensure that the grill can be operated in a safe and secure manner.

## TURNING OFF YOUR SMARTGRILL BY LYNX™

Your SmartGrill by Lynx™ can be shut down by any of the following methods.

- Your SmartGrill by Lynx™ can be deactivated by pressing the POWER ON/OFF switch located on the left hand side of the grill.
- Your SmartGrill by Lynx™ can be shut off by saying "SmartGrill shut down."
- Your SmartGrill by Lynx™ can be shut off by clicking on the red "Off" switch in the SmartGrill by Lynx™ app. Note that you will be asked to confirm this command.



## AUTO SHUTDOWN SYSTEM

Your SmartGrill by Lynx™ is equipped with an auto shutdown safety system that will shut off the grill if the grill has not:

- Received any verbal commands for 30 minutes.
- Received any commands via the SmartGrill by Lynx™ app in 30 minutes
- Had the temperature adjusted by one of the manual knobs for the last 30 minutes.

Note that the auto shutdown system is disengaged while the SmartGrill by Lynx™ is working through a step in Recipe Cook or counting down in Timed Cook. It can also be disabled with the verbal command "SmartGrill disable shutdown."

If you need cooking time longer than 30 minutes, you can change the auto shutdown timer on your app.

- Click on the Resources Icon
- Select My SmartGrill
- Select Auto Shutdown
- Change the amount of time for auto shutdown
- Select Set Time

# PRE-GRILL CHECKLIST

## BEFORE YOUR FIRST USE

There are a few must-check safety precautions to consider before you use your grill. Please be sure that:

- All packing materials and tie-downs have been removed from the burners. (See INDEX: "Unpacking & Assembly" for further details.)
- You have plugged in the electric cord. (See INDEX: "Electric Requirements" for further details.)
- A qualified plumber has performed a leak test on all the fittings that supply fuel to your grill.
- You have downloaded and set up the SmartGrill by Lynx™ App. (See INDEX: "Downloading Your SmartGrill by Lynx™ App for iOS and Android devices.")
- You have connected your SmartGrill by Lynx™ to your home's wireless network. (See INDEX: "Connecting Your SmartGrill by Lynx™ to a Wireless Network.")

## CALIBRATING YOUR SMARTGRILL BY LYNX™

Before your first grilling session, use your SmartGrill app or voice command to calibrate your SmartGrill by Lynx™. This will set a minimum flame level which is affected by ambient temperature, altitude, wind conditions and more. Calibration is required for optimum performance of your SmartGrill. The calibration process will take 15-20 minutes.

To perform a calibration, please close the hood of the grill, then:

By Voice Command: "SmartGrill, begin calibration."

By App:

- Go to Resources
- Select My SmartGrill
- Select Calibrate Grill
- Select Automatic Calibration

---

## PRE-GRILL CHECKLIST ...*continued*

---

SmartGrill will automatically shutdown when calibration is complete. It will say "Calibration complete" or send you the same message on your app. If the calibration fails, SmartGrill will say "Calibration failed" or send you the same message on your app.

---

### AT EACH NEW SEASON

---

At the start of each new grilling season you should remove the grilling racks and check the burners, venturis, orifices, and valves for obstructions.

Spiders and insects often nest in these areas of the grill and can disrupt airflow, causing damage to the grill and personal injury.

Also, check all hoses, wires, and fitting for damage, abrasion, wear and tear.

---

### CHECKLIST BEFORE EACH USE (FOR YOUR SAFETY)

---

- Do you smell gas? If yes, shut everything off and call the gas company or a qualified plumber to check for leaks. If not, please continue.
- Is your cooking area free and clear of any combustibles besides your food that might ignite? If not, please clear the area before starting the lighting process. If yes, please continue.
- If you are using a portable propane cylinder, is it connected and leak tested? If not, check the connection before continuing. If yes, please continue.
- Are all burners properly seated in the grill with the venturi of the burner over the orifice and the center crossbar in the bracket? If not, seat the burners properly before continuing. If yes, please continue.
- Is the wind blowing just lightly and not blowing on the back of the grill? If not, wait until the wind subsides or turn your free standing grill so the wind goes into the front of the grill. If yes, please continue with the lighting process.

---

### HOW TO LIGHT YOUR GRILL

---

- Before each use, complete the checklist above
- Remove the grill cover.
- Make sure all burners are in the OFF position.
- Press the ON/OFF button. The blue LED lights that surround the knobs will indicate that the grill is energized. After 5-20 seconds SmartGrill will say "SmartGrill at your service."
- Select which mode of operation you would like to use from below;

- **Manual Cook:** Turn the knob that corresponds to the burner you wish to light by turning the knob clockwise 2 full revolutions. SmartGrill will say, "SmartGrill in manual cook mode."
- **Timed Cook:** Select an amount of time to cook, and a temperature.
  - To select an amount of time to cook, use the voice command: "SmartGrill, Use <N> burner" where N is 1, 2, or 3 – the number of the burner you wish to use. When you receive confirmation from the SmartGrill by Lynx™, use the voice command: "SmartGrill, Add <X> minutes" where X is the number of minutes you wish to cook. You can also use the app to select the time and temperature for your timed cook.
- **Recipe Cook:** Select the recipe you wish to use in the app and send it to the grill. The SmartGrill by Lynx™'s MyChef technology will handle the lighting and all temperature controls based on the recipe. See SmartGrill Recipe Mode on page 23 for details.
- **Meal Mode:** Meal mode is a revolutionary and completely intuitive method of setting up your entire meal from grilled appetizers to desserts. Simply use the SmartGrill app to set your courses, recipes per each course, and the SmartGrill will ensure each meal item is completed at the same time.
- **Party Mode:** Party mode allows you to continually cook foods on all your SmartGrill burners, perfect for when you are hosting a party and need a constant stream of goodies coming off your grill!

# BASIC OPERATIONS

## MANUAL MODE

During Manual Cook, temperature is controlled by the knobs on the front panel of the SmartGrill by Lynx™. Manual Cook operates just like a traditional grill where you control the temperature and time to cook your meal.

Spin the knob of the burner you wish to use two full rotations clockwise to light the burner. Spin the knob two full rotations counter-clockwise to turn the burner off. (This will not turn the grill power off.)

Note that turning the knobs will ALWAYS cancel Timed Cook, Recipe Mode, Meal Mode, and Party Mode and put the grill into Manual Cook.

## TIMED COOK

Timed Cook allows you to grill without a recipe by utilizing the SmartGrill's MyChef™ technology to select a cooking time, burner, and temperature.

To enter Timed Cook mode:

- Open the SmartGrill App
- Select the My Grill icon
- Select a burner
- Select Timed Cook
- Set the time
- Set the temperature
- Set a reminder time
- Select "Cook Now"

To cancel a Timed Cook:

From the app select the burner then select Cancel Recipe.

## RECIPE MODE

- Once the cooking process begins, it can be controlled through the use of verbal commands or via the SmartGrill by Lynx™ app.
- Pre-heating and temperature control is automatically controlled by MyChef™.
- Start your SmartGrill by Lynx™ App
- Click on "Recipe" tab
  - "Lynx" features all recipes created by our executive chef specifically for the SmartGrill by Lynx™
  - "My Recipes" includes all user-created SmartGrill recipes
  - "Community" contains all the recipes shared by other

SmartGrill users

- Select the recipe you wish to use
- Click "Cook Now"
- Choose the number of burners you wish to use and modify cooking time if needed.
- Click on "Cook Now" to start the cooking process.
- The cooking process can be completed or aborted via a verbal or text command from the cook. (See Page 24: "Voice Commands" for more information.)

## MEAL MODE

Meal mode is a revolutionary and completely intuitive method of setting up your entire meal from grilled appetizers to desserts. Simply use the SmartGrill app to set your courses, recipes per each course, and the SmartGrill will ensure each meal item is completed at the same time. To enter Meal Mode do the following:

- Open the SmartGrill App
- Select the My Chef icon
- Select Meal Mode
- Select Create Meal
- Enter a name for your meal such as "Sunday Dinner" or "Mom's favorite dinner"
- Select the meal name that you just created
- Select the menu and select **Add Course**
- You can change the name of the course or just accept the default course number and click **OK**
- Select the Course name you just created and select the **Add**
- Now choose a recipe
- If you would like to add another recipe to this course select **Add** again. Do this for as many recipes as you would like to add to this course.
- On your device click your back button to get to the Course's menu.
- You may now repeat the above steps to add additional courses or recipes to your courses.

If you would like to get a shopping list for your meal you can click on the **Shopping List** icon and choose Print. Follow the prompts for your device to Print and/or email the shopping list.

To cook your meal select **Cook Now** and follow the prompts from the grill.



---

## BASIC OPERATIONS ...*continued*

---

### PARTY MODE

---

Party mode allows you to continually cook foods on all your SmartGrill burners, perfect for when you are hosting a party and need a constant stream of goodies coming off your grill! To enter Party Mode:

- Select **My Chef**
- Select **Party Mode**

---

## VOICE COMMANDS

---

### BASIC COMMANDS

---

Your SmartGrill by Lynx™ can be completely controlled by using a series of pre-set voice commands. The SmartGrill will not respond to any voice commands if it is not in Listen Mode (see Listen Mode instructions page 23). What follows are the most important voice commands you will need to control your grill:

**Command:** "SmartGrill, shut down."

**Function:** This command will cancel any current recipes, shut down all the burners and turn the grill off.

**Command:** "SmartGrill, Lights"

**Function:** This command will turn halogen lights over the cooking surface on or off.

**Command:** "SmartGrill, Update"

**Function:** This command will give you an audible status report on all of the SmartGrill by Lynx™'s burners.

**Command:** "SmartGrill, continue cooking."

**Function:** Resets auto shutdown timer back to 30 minutes.

**Command:** "SmartGrill, Disable Shutdown."

**Function:** Once you use this command, you will have to use either a voice command, the SmartGrill by Lynx™ app, or the ON/OFF button on the front panel of the SmartGrill by Lynx™ in order to shut the grill off.

**Command:** "SmartGrill, Begin Calibration"

**Function:** Begins a calibration routine meant to capture the lowest gas value for each burner that can safely maintain flame. The process also burns all burners at high for 5 minutes to burn off factory oils (on your first use) or excess food particles after grilling. Cannot be used during a recipe.

**Command:** "SmartGrill, Network Status"

- Select **Add Recipe to List**
- Select your recipes and add as many as you would like to the list
- Select **Start Cooking**

**Function:** Provides an audible notification indicating if the grill is currently connected to the server or not.

**Command:** "SmartGrill, Can You Repeat That"

**Function:** Repeats the audible notification last spoken by the grill.

---

### COOKING COMMANDS

---

**Command:** "SmartGrill, Cook <recipe name>"

**Function:** This starts a Recipe using one of the recipes included in the Lynx recipe database that can be seen using the SmartGrill by Lynx™ app. The SmartGrill by Lynx™ will make sure that burners are available for use, then ask you how many burners you would like to use.

**Command:** "SmartGrill, Update <recipe name>"

**Function:** This command will give you an update on the status of a specific recipe.

**Command:** "SmartGrill, Rotisserie <recipe name>"

**Function:** This starts a Recipe using single rotisserie and one of recipes included in the Lynx recipe database that can be seen using the SmartGrill by Lynx™ app. The SmartGrill by Lynx™ will make sure that the rotisserie is available for use, and then ask you for the cooking time. The rotisserie motor must be attached and plugged in to the grill. The rotisserie motor must be started manually.

**Command:** "SmartGrill, Use <1 burner, 2 burners, 3 burners>"

**Function:** When asked by the SmartGrill by Lynx™ which burner to use, this command is how to answer.

**Command:** "SmartGrill, Same as Last Time."

**Function:** When asked by the SmartGrill by Lynx™ how much time you wish to cook for, this command will default either to the amount of time specified in the recipe or to the

---

## VOICE COMMANDS ...continued

---

adjusted time the user specified the last time the recipe was used.

**Command:** "SmartGrill, Add 30 seconds."

**Function:** Adds 30 seconds to the amount of time specified in the recipe or to the adjusted time you specified the last time the recipe was used. See the Time Phrases list page 27.

**Command:** "SmartGrill, Subtract 30 seconds."

**Function:** SmartGrill will subtract 30 seconds to the amount of time specified in the recipe, or to the adjusted time you specified the last time the recipe was used. See the Time Phrases list on page 27.

**Command:** "SmartGrill, <recipe><transition>"

**Function:** When asked to transition the food on the grill for a recipe, this command is how you let the SmartGrill by Lynx™ know that it's been accomplished. If, for example, the SmartGrill by Lynx™ asks you to "Flip Steaks," You would respond "SmartGrill, steaks flipped."

**Command:** "SmartGrill, <burner #> <transition>"

**Function:** You can also choose to transition food by referencing the burner, rather than recipe. For example, if you have food on burners 1 and 2 that need to be flipped, simply say "SmartGrill, burner 1 flipped." Alternatively, you can also say, "SmartGrill, burner 2 flipped." Transition either burner will work, so long as they are cooking the same recipe.

**Command:** "SmartGrill, Previous Step"

**Function:** Commands SmartGrill to repeat the last voice prompt it gave. Helpful if you are doing a multi-step recipe.

**Command:** "SmartGrill, Thank You."

**Function:** When the recipe has completed cooking, this command lets the SmartGrill by Lynx™ know that cooking has been completed and that it can shut down the burners.

**Note that this command does not shut off the grill.**

---

## USING YOUR SMARTGRILL BY LYNX™ RECIPE DATABASE

---

Your SmartGrill by Lynx™ recipe database is accessed via your SmartGrill by Lynx™ App by clicking on the "Recipes" tab at the bottom of the screen. Recipes available to cook are listed on the left hand side under three categories: "Lynx," "My recipes," and "Community."

### Lynx Recipes

Lynx recipes are recipes that have been specially formulated for the SmartGrill by Lynx™ by Lynx's own executive chefs. The Lynx database of recipes numbered 400 when the unit first shipped, however this database will be automatically updated with new recipes at regular intervals.

Your SmartGrill by Lynx™ is ready to start grilling the following recipes by voice command even if you are not connected to a smart device.

- Ahi Tuna - 2 Inch - Seared
- Bratwurst, Large
- Chicken - Half Split - Medium
- Chicken - Whole - Medium
- Chicken Kebabs - Medium
- Chicken Wings - Large
- Corn On The Cob
- Filet Mignon - 2 Inch - Medium Rare

- Halibut Steak - Large
- Hamburger - 1/2 Inch - Medium
- Hot Dog - Medium
- New York Strip - 2 Inch - Medium Rare
- Pork Chops - 2 Inch
- Prime Rib Roast
- Rib Eye Steak - 1 Inch - Medium
- Rib Eye Steak - 2 Inch - Medium Rare
- Salmon - 2 Inch - Medium
- Scallops - Medium
- Swordfish Steak - Large
- T-Bone Steak - 2 Inch - Medium
- Top Sirloin - 2 Inch - Medium Rare

For example, to start one of these recipes, use the command "SmartGrill, Cook Hot Dog, Medium". You must use the exact title of the recipe for the SmartGrill's word recognition. Continue to follow the voice prompts or use your app to complete the cooking process.

After you send a recipe from the app to the SmartGrill, you can use voice commands to complete the recipe, and use it again in the future.

Your SmartGrill by Lynx™ can hold thousands of recipes. You can start a recipe with a voice command for up to 100

---

## USING YOUR SMARTGRILL BY LYNX™ RECIPE DATABASE ...continued

---

recipes at a time. Your 101st recipe will replace the least used recipe, and will continue to cycle, allowing you to access 100 different recipes by voice command at any time. You can always send a new recipe to the SmartGrill, and grill using either voice commands or the app or both to complete the recipe.

### My Recipes

The "My Recipes" tab is where you can store your own recipes that will then be followed by the SmartGrill by Lynx™. To create your own recipe:

- Click on the "+" sign to bring up the "New Recipe" Screen
- Click on the "Recipe Name" field to input a name for your recipe.
- Click on "Grill" or "Rotisserie" to choose between grilling and using the rotisserie. Note the rotisserie motor must be attached, plugged in, and started manually.
- Click on Food Type to choose the type of food your recipe will use.
- Click on the "Share on Community" switch so that it shows green if you wish to share your recipe with the Lynx SmartGrill by Lynx™ community.
- The Ingredients and Directions tabs are text screens

where you can put down ingredients and the recipe directions, respectively.

- Click on the "Add Step" to input the recipe's step name, the action you will need to take in the recipe, the temperature for the grill and the amount of cooking time the step will take. Click "Done" when you've completed entering the step.
- Note that you may enter as many steps as you wish.

When you've completed entering the recipe information, add a last step to "Remove Food". Then click on "Done" to save it to your database.

### Community

This tab contains a selection of recipes created and uploaded in "My Recipe" by the community of SmartGrill by Lynx™ users.

When you have selected the recipe you wish to use, click "Cook Now". Then:

- Choose the number of burners you wish to use on the "Send to grill" screen.
- Click on "Send to Grill."
- Follow the verbal and command prompts to carry out the recipe.

---

## USING YOUR SMARTGRILL BY LYNX™ RECIPE DATABASE

---

### SIMULTANEOUS MANUAL AND AUTOMATIC CONTROL

When beginning a Recipe Cook or Timed Cook, your SmartGrill by Lynx™ will automatically default to using burner number 1. This can be changed through the use of verbal commands (See INDEX: "Voice Commands"). During this cooking process, the other burners can be used in manual mode by turning their corresponding dials to the desired temperature.

### DIRECT HEATING

Direct heat cooking occurs when food is placed directly over the heat source. This form of heat is known as "radiant" heat because the heat radiates directly from the source to the food.

Direct heat is a must when you want to sear the outside of your food to seal in flavor. Lynx ProSear™2 Burners provide the heat necessary to sear foods and seal in flavor.

### INDIRECT HEATING

It is possible to turn on burners 1 and 3 and place the food over burner 2. This type of cooking is called "indirect heating" and can only be achieved under manual control. All recipes in Timed Cook, Recipe Cook, Meal Mode, and Party Mode must be done via direct heating.

### CANCELLATION COMMANDS

**Command:** "SmartGrill, Cancel <RecipeName>"

**Function:** This command will cancel the selected recipe. The SmartGrill by Lynx™ will then ask if you wish to shut down the burners or continue cooking in Manual mode.

**Note that this command does not shut off the grill.**

**Command:** "SmartGrill, Override <RecipeName>"

**Function:** This command will cancel the ongoing recipe and leave the burners on for manual usage.

**Command:** "SmartGrill, Turn off burners."

## ADVANCED OPERATIONS

**Function:** After you cancel a recipe, this command will shut down the grill's burners. **Note that this command does not shut off the grill. To shut off the grill, press the button on the left front, give the voice command "SmartGrill, shutdown" or use the app and click on shutdown.**

**Command:** "SmartGrill, Cook Manually."

**Function:** After you cancel a recipe, this command will move the SmartGrill by Lynx™ into Manual cooking mode.

### TIME PHRASE LIST

#### Main Burner recipe options:

- "thirty seconds"
- "one minute"
- "two minutes"
- "one minute, thirty seconds"
- "two minutes"
- "two minutes, thirty seconds"
- "three minutes"

#### Rotisserie recipe options

- "fifteen minutes"
- "thirty minutes"
- "forty five minutes"
- "one hour"

### LISTEN MODE

Listen Mode turns SmartGrill's listening and speaking ability on and off. You may want to turn off Listen Mode during a gathering around the grill when many people are talking. The SmartGrill may pick up a voice that it interprets as a

command. It may say "Please repeat that" or a command not within your menu.

You must use the app to turn off Listen Mode:

- Press the SmartGrill menu icon. At the bottom of the menu are "Grill Controls."
- Press the "Listen Mode" icon. When an X shows next to the speaker, your Listen Mode is off. At this point, the grill will respond only to the app. It will not respond to voice commands.

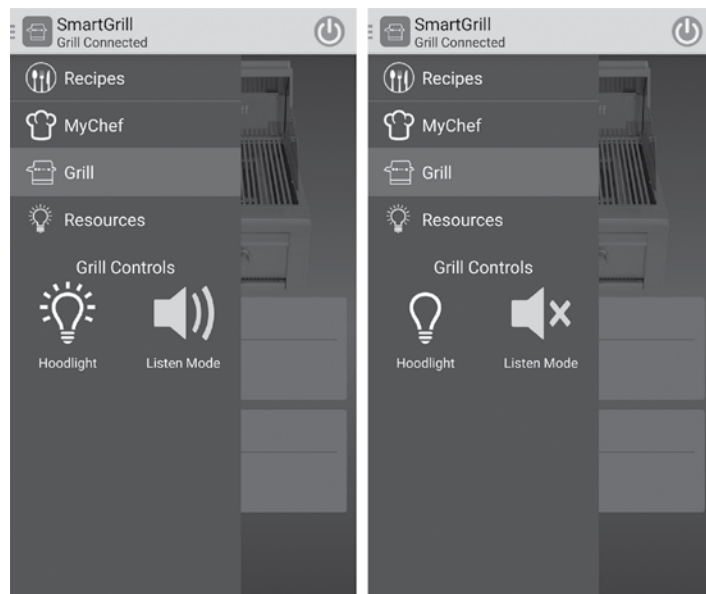

Be sure to turn your Listen Mode back on at the end of your grilling session. If you do not turn it back on, the next time you start SmartGrill, it will not respond to your voice commands.

To turn Listen Mode back on:

- Press the SmartGrill menu icon.
- At the bottom of the menu under "Grill Controls", press the "Listen Mode" icon. The X should disappear, and your SmartGrill will be able to listen.

## CLEANING YOUR SMARTGRILL BY LYNX™

### STAINLESS STEEL

Lynx products are known for their attractive appearance. We achieve this by selecting only the finest grades of stainless steel and applying exacting workmanship.

In order to maintain this attractive appearance over the life of the grill, it is important to take the following steps:

- After each use, wipe down the exterior of the grill to remove grease and splatters.

- Be sure to follow the cleaning instructions for keeping the cooking surface clean and ready for use.
- Use a commercially available Stainless Steel cleaner to clean and polish the exterior surfaces.

Doing these things on a regular basis minimizes the amount of effort required.

Part of the appeal of your Lynx SmartGrill by Lynx™ is the fine grain finish. When removing stubborn stains:

## CLEANING YOUR SMARTGRILL BY LYNX™ ...continued

- Do not use metallic abrasives and always rub in the direction of the grain.



- Some household cleaning products are not suitable for stainless steel and high heat; be sure to read the label before using on your SmartGrill by Lynx™.
- Always use the mildest cleaning solution first, scrubbing in the direction of the grain. Specks of grease may gather in the grain of the stainless steel and bake onto the surface, giving the appearance of rust.

To remove these baked on foods, use a fine to medium grit non-metallic abrasive pad (Scotch Brite is good) in conjunction with a stainless steel cleaner.

- **Solutions used for cleaning concrete and masonry can be very corrosive and will attack stainless steel. Ensure your Lynx products are well protected before you allow the use of such chemicals near your grill.**

### SPECIAL NOTE FOR LOCATIONS NEAR POOLS AND COASTAL AREAS:

The 304 stainless steel material used in the construction of a Lynx SmartGrill by Lynx™ is highly rust resistant, however chlorine in the air from swimming pools or salt in the sea air may cause surface rust to appear and even create some pitting if left on the product.

Here are a few tips to avoid this:

- Regularly wipe down the exterior surfaces with a damp cloth (Micro fiber cloths such as Ecloth perform very well.)
- Allow the surfaces to dry before installing the cover. Do not cover a damp grill.
- In extreme environments, apply a rust inhibitor which leaves a microscopic protective layer on the grill. Products that provide a layer of vapor corrosion inhibitors (VpCI™) protect the surface very well.
- For seasonal storage use the product referred to above, ensure the grill is dry and then cover and secure the cover to minimize the amount of damp air getting to the surfaces.

THE LYNX LIMITED LIFETIME WARRANTY PROVIDES PROTECTION AGAINST RUST THROUGHOUT OF PARTS THAT RENDER THE PRODUCT INOPERATIVE. IT DOES NOT COVER OCCASIONAL SURFACE RUST OR STAINING DUE TO ENVIRONMENTAL CONDITIONS.

After your first use, certain areas of the grill may discolor from the intense heat given off by the burners – this is normal and cannot be cleaned off.

For light and heavy food stains there are many different stainless steel cleaners available.

### DRIP TRAY

The drip tray should be cleaned after each use. After the grill is completely cool, remove the drip tray by pulling it forward and up, lifting it out.

It can be wiped down with a paper towel.



### WARNING

DO NOT ALLOW EXCESS GREASE OR LIQUIDS TO ACCUMULATE IN THE DRIP TRAY AS THIS MAY CREATE A FIRE HAZARD.

NEVER USE GRILL WITHOUT DRIP TRAY PROPERLY INSTALLED.

### PROSEAR2 BURNERS

With the hood up, turn all burners on high for 5 minutes. Do not touch the ceramic surfaces, and do not use water or cleaner on the ceramic surface. Do not poke anything into the holes in the ceramic.

Every three to six months, remove the burners and inspect the venturi (inlet) and orifice to ensure they are free of obstructions.

Food debris on the inside of the burners can be gently shaken out.

While the burners are removed, remove the grease and debris off the bottom of the firebox.

When re-installing the ProSear™2 burners, be sure to correctly position the burners.



### WARNING: BURNER PLACEMENT

PROPER PLACEMENT OF EACH BURNER IS CRITICAL AFTER CLEANING. THE VENTURI MUST BE CENTERED OVER THE BRASS ORIFICE, RESTING LEVEL WITHOUT ANY ROCKING, AND THE CROSS BAR MUST BE SEATED IN THE CENTER BRACKET.

FAILURE TO MEET THESE CONDITIONS MAY CAUSE A VERY DANGEROUS CONDITION THAT CAN CAUSE PERSONAL INJURY AND DAMAGE PROPERTY.

## TROUBLESHOOTING YOUR SMARTGRILL BY LYNX™

### SMELL OF GAS WHILE COOKING

If you smell gas while the grill is operating, immediately turn off all burners and shut off the main fuel supply.

- Perform a leak test. (See INDEX: "Leak Test procedure" for further details)
- Check for blockages.

### BEFORE YOU CALL FOR SERVICE

Please check a few things before calling for service:

- Is there fuel supplied to the grill?
- Is the main shut off valve open?
- Are you using the correct type of fuel (Liquid propane or natural gas)
- Is your propane cylinder empty? Have you recently refilled the propane cylinder? If so, is the connection tight?
- Have you opened the valve on the propane cylinder?
- Is the grill plugged in to a live electric circuit?
- Has the GFI outlet tripped requiring a reset?

### PROBLEMS WITH WIRELESS CONNECTIVITY

First, go to the location of your grill with your iOS or Android device. How strong is your signal at that location? For optimum performance, you will need a 60% signal. If not, please check with your Wi-Fi installer to boost the strength.

Is your SmartGrill within 100 feet of your router? If not, you may need to boost signal strength.

Do you have an N version router? The SmartGrill by Lynx™ will perform better with an N router.

Do you have the correct operating system on your smart device?

iPhone 5, 5C, 6, or newer, iPad version 2.0 or newer or Android 4.4 operating system or newer

To find your operating system on your smart device:

**iPhone and iPad:** Go to Settings /General/ About/ Phone to find your model number

**Android:** Go to Settings, About Phone, Android version

Then, make sure that your wireless network is connected properly and is broadcasting at least a 60% signal to reach your grill. After that, proceed through the wireless connection sequence:

- Activate your iOS or Android device
- Click on the "Settings" app
- In Settings, click on "Wi-Fi"
- You will see "SmartGrill by Lynx™" in the selections under "Choose a Network."
- Tap SmartGrill by Lynx™ to connect to the SmartGrill by Lynx™ Wi-fi spot
- Shut down the Settings app
- Activate the SmartGrill by Lynx™ app.

If this is the first time you've activated your SmartGrill by Lynx™ app, you will be asked to input a PIN number and the serial number for the Grill.



## TROUBLESHOOTING ...continued

- The four digit PIN can be located on the rating plate. This is your personal number that insures that no version of the SmartGrill by Lynx™ app save yours is able to control your SmartGrill by Lynx™.
- Input the SmartGrill by Lynx™'s Serial Number. This serial number can be found on the last page of this Care & Use manual or on the underside of the SmartGrill by Lynx™'s drip tray. (See INDEX: "Downloading and installing your SmartGrill by Lynx™ App".)
- Once the app has been connected to the SmartGrill by Lynx™, the app will open up the "Grill Status" page. Click the light bulb labeled "Support" at the bottom of the screen.
- Click "Wi-Fi" settings
- You will see a list of networks available for your SmartGrill by Lynx™ Choose your home network.
- Depending on your security settings, you may need to enter your home network's password to allow the SmartGrill by Lynx™ to access it.
- Once the SmartGrill by Lynx™ has successfully accessed your home network, you will receive a "Success" message.

Once you have successfully connected the SmartGrill by Lynx™ to your home network, you may have to return to your device's "Settings" app and reconnect with your home network.

### FACTORY RESET

If needed, the Wi-Fi setting in your grill can be reset. Press the power button to turn the grill off. Then press and hold the Power button in the OFF position for 15 seconds.

If a factory reset is done, you will have to setup your Wi-Fi connection again. Please refer to the Quick Start Guide for setup procedure.

### GRILL WON'T LIGHT

First, confirm that the grill is getting electricity by checking the lights that surround the dials on the front panel of your SmartGrill by Lynx™.

#### Check the Igniters

Your Lynx SmartGrill by Lynx™ uses an electric ignition system that does not spark. Instead the igniters will glow

constantly when a control knob is turned on. If one of your igniters is not working, SmartGrill will say or send you a text of "Igniter Failure".

- Ensure that all burners are set to OFF
- Remove a cooking grate so you can clearly see the igniter.
- Turn the burner knob ON (two full rotations clockwise) and wait approximately one minute for the igniter to glow.
- Check all igniters. If they do not glow, call Lynx for service at 888-289-5969.

#### Check the Burners

If your burner fails to ignite, SmartGrill will text or say "Burner <N> has no flame." If the burner has no flame, SmartGrill will turn off the gas to that burner.

Be careful! If the burner fails to ignite, wait five minutes before attempting to ignite other burners!

Check to make sure your gas line is connected and the shut off valve is turned on. Re-check fuel connections for leaks and ensure the supply is of the correct type and is of adequate pressure. (See INDEX: "Leak Test Procedure" for further details.)

If you know you are getting gas, wait for any gas to dissipate and remove the burner and check for gas blockages.

Replace any damaged supply lines.

- Check the regulator.

Make sure that the regulator and hose assembly is the one designed for and supplied with your Lynx grill and that it is correctly set up for the type of fuel you are using. (See INDEX: "Regulator Conversion" for further details.)

The hose and regulator provided by Lynx Grills must be used if your grill is set up for use with a liquid propane gas cylinder.

Check that there is no physical pressure being applied to the regulator attached to the back of the grill. The regulator contains a flexible diaphragm and should not be allowed to touch the grill body or its surroundings.

- Check for obstructions.

Ensure that the burners and the drip tray are clean and free from obstructions.

#### Liquid Propane Units:

---

## TROUBLESHOOTING ...continued

---

- Is the cylinder almost empty?

Almost empty cylinders may not have sufficient pressure to run the burners at high heat.

- Have the line pressure checked by a qualified technician.
- Flow limiting device.

Improper lighting procedure may have activated the liquid propane cylinder's flow control device, reducing heat output.

### To reset the flow control:

- Shut off all burner controls and close the liquid propane cylinder valve.
- Open one gas valve to relieve any pressure in the LP hose, then close the gas valve
- Wait 30 seconds and, very slowly, reopen the cylinder valve.

Wait a few seconds and relight a burner.

### Bulk Liquid Propane cylinder users:

Bulk liquid propane cylinder lines must be properly regulated.

Ensure that you are using a 4/11 appliance regulator supplied by Lynx and converted to liquid propane gas. Also, ensure that you do not have more than one regulator in line.

### Natural Gas Units:

- Supply line

Ensure that the supply line is at least ¾" inside diameter or 1" outside diameter.

- Check Line pressure

Natural gas inlet pressure should be at least 5" W.C. and manifold pressure not less than 4" W.C. under full load (with all burners on).

- Check burners for blockages.

---

### LOW OR INSUFFICIENT HEAT

---

Proper levelling during installation is critical. A grill that is out of level will cause erratic burner combustion and inefficient, uneven heating. A carpenter's spirit level should be used to level the grill both front-to-back and side-to-side.

If the low heat problem persists:

- Check the gas supply line sizing requirements.

- Check the gas supply line for kinks or damage.
- Check the thermostatic control for proper operation.

---

### LIGHTS WON'T LIGHT

---

- For the blue LED lights and white halogen lights
- Check power

Ensure that the grill is connected to a live AC power source.

---

### SMARTGRILL SELF-DIAGNOSIS

---

Your SmartGrill by Lynx™ technology includes self-diagnosis of some issues and will let you know either with an audible statement of the issue, or send you a text message displayed in your app. "Burner <N>" indicates the SmartGrill will tell you if it is Burner 1, 2, 3, or the Top Burner (rotisserie). Any time a burner does not light, the SmartGrill will turn that burner off.

**Audible:** "Burner <N> igniter malfunctioned."

**Text:** "Igniter failed to start."

Indicates the igniter has a problem. Check to see if gas is turned on. Wait 5 minutes for the gas to dissipate, then try lighting it again. Call Lynx at 888-289-5969.

**Audible:** "Burner <N> ignition malfunction."

**Text:** "Burner <N> failed to ignite ."

Indicates the burner is not lit. Check to see if gas is turned on. Wait 5 minutes for the gas to dissipate, then try lighting it again. If it still does not light, call Lynx at 888-289-5969.

**Audible:** "Burner <N> could not stabilize."

**Text:** "Burner <N> failed to stabilize."

The burner was set a little too cool. Wait 5 minutes for the gas to dissipate, then light it again. Leave it on high for a little longer to heat up before adjusting it down to your target temperature.

**Audible:** "Burner <N> cannot reach target temperature."

**Text:** "Burner <N> cannot reach target temperature."

Check to see if gas is turned on. Wait 5 minutes for the gas to dissipate, then try lighting it again. If it still does not light, call Lynx at 888-289-5969.

**Audible:** "Burner <N> has no flame."

**Text:** "Burner <N> has no flame."



## TROUBLESHOOTING ...continued

Check to see if the gas is turned on. Wait 5 minutes for the gas to dissipate, then try lighting it again. Check If it still does not light, call Lynx at 888-289-5969.

**Audible:** "Burner <N> turned on unexpectedly."

**Text:** "Burner <N> turned on unexpectedly."

Check grill to see if someone else is using the grill manually. If not, shut down that burner and watch to see if it lights unexpectedly again. If so, call Lynx at 888-289-5969.

**Audible:** "Burner <N> temperature not maintained."

**Text:** "Burner <N> temperature not steady."

Check area around grill for breeze or wind (see INDEX "Grilling in Windy Conditions"; confirm your gas is on, and if you have a propane bottle, that it has enough gas in it.

**Audible:** "Error encountered. Please unplug and re-plug SmartGrill power cable."

**Text:** "Error encountered. Please unplug and re-plug SmartGrill power cable."

Unplug and re-plug your power cable. Wait 20-60 seconds to hear "SmartGrill is ready," then press the power button. If the SmartGrill still does not function, call Lynx at 888-289-5969.

**Audible:** "Ambient temperature too high."

**Text:** "Ambient temperature too high."

The temperature around the PC or the circuit board in the grill head is too hot. Turn the grill off and allow it to cool. Try the grill again after it has cooled off.

**Audible:** "Burner <N> knob is malfunctioning."

**Text:** "Burner <N> knob has malfunctioned."

Indicates that a knob is missing or not connecting to the grill correctly. The grill will turn that burner off until the knob is fixed. Replace any knob that has been removed or fallen off. If the problem persists, call Lynx at 888-289-5969.

**Audible:** "Burner <N> gas valve is malfunctioning."

**Text:** "Burner <N> gas valve has malfunctioned."

Indicates gas is not flowing through the valve. Check to be sure the gas is turned on, and there is enough gas in your propane bottle. The grill will turn this burner off until the valve is fixed. Call Lynx at 888-289-5969.

**Audible:** "Burner<N> valve short circuit."

**Text:** "Burner<N> gas valve has short circuited."

Shutdown the burner with the problem and call Lynx at 888-289-5969.

## NETWORK TROUBLESHOOTING

If you do not have at least a 60% signal on your smart device while standing at your grill, your grill will not perform optimally. Here are some suggestions for improving your network:

Position your wireless router, modem router, or access point in a central location. The best place for a Wi-Fi router is in the center of your home.

- The distance between your router and your SmartGrill should not exceed 50 ft.
- Verify that there are no obstacles between your SmartGrill and the router.
- Appliances, metal objects, cordless phones, stone walls, fireplaces, etc. decrease Wi-Fi strength.
- Check the cable that connects the modem to the router to make sure it is in good condition. If not, replace the cable.
- Replace your router antenna with a Hi-Gain wireless antenna. They boost the signal strength and aim the signal in one direction.
- Reduce wireless interferences by using devices that communicate via the 5.0 GHz frequency instead of the more common 2.4 GHz frequency (same frequency as baby monitors, garage door openers, cordless phones, microwave ovens).
- Connect your SmartGrill to your router using a CAT 5E or better cable and then try to setup a wired network connection.

Add a wireless repeater

A wireless repeater is a device that extends your wireless network's range without requiring you to add any wiring. Place the repeater halfway between your wireless router and your SmartGrill to get an instant boost in your wireless strength.

Add an extended antenna

Sometimes when a SmartGrill is built-in to an island, the antenna cannot pickup a strong enough signal to run the SmartGrill. If this is the issue, please call Lynx to request an antenna extension at 888-289-5969 option 5.

For additional troubleshooting of wireless connections, contact your local Wi-Fi installation expert.

## OBTAINING SERVICE FROM LYNX

Before calling Lynx Customer Care, please make sure you have the following information:

- Model number
- Date of purchase
- Proof of purchase by the original owner
- Serial number for grill (located on the rating plate in this Care and Use Manual and on the bottom of the drip tray)
- Serial number for the CPU (located on the rating plate on the front of the CPU case).



For Warranty Service or a referral for an authorized service agent near you, contact Lynx Customer Care at:

**(888) 289-5969**

Agents are available Mon-Fri from 6AM to 4:30 PM, and Saturday from 8AM to 1PM Pacific Time.

**[www.lynxgrills.com](http://www.lynxgrills.com)**

Your satisfaction is of the utmost importance to us. If a problem cannot be solved to your satisfaction, please call, write, fax or email us:

Lynx Professional Grills

7300 Flores Street

Downey, CA 90242

Service: (888) 289-5969

Tel: (562) 299-6900

Fax: (562) 299-6978

[service@lynxgrills.com](mailto:service@lynxgrills.com)

Contact Lynx for replacement parts. Parts are shipped F.O.B. Downey, CA.

## THE LYNX STORY

Lynx began with a vision.

A small group of manufacturing engineers with over a century of collective experience had a dream. They dared to take their extensive commercial manufacturing know how and create a line of outdoor cooking products that offer commercial elegance and performance to the consumer market.



Lynx has taken the quality, workmanship, service and innovation of the commercial market and incorporated it into the Lynx Professional grills line of consumer and commercial products. The combination of creative design, superior materials and exceptional craftsmanship elevates Lynx products to a class of their own.

Lynx original commercial products are used every day in restaurants, hotels, and theme parks across the USA:

### LYNX SATISFIED CUSTOMERS

- TGI Fridays
- Applebee's
- Houston's
- Red Lobster
- Hard Rock Café
- Wolfgang Puck's
- Cheesecake Factory
- Red Robin
- Planet Hollywood
- Hilton
- Hyatt
- Four Seasons Marriott
- Le Meridian
- Sheraton
- Conrad International
- Bellagio
- New York New York
- MGM Grand
- Treasure Island
- Mirage
- Paris
- Excalibur
- Mandalay Bay
- Riviera
- Desert Inn
- Hard Rock Hotel
- Disney World

# SMARTGRILL BY LYNX™ LIMITED WARRANTY

## I. Limited Lifetime Warranty

The stainless steel grill body, cooking grates, ProSear™ burner and rotisserie infrared burner are warranted to be free from defects in material and workmanship when subjected to normal domestic use and service for the lifetime of the original purchaser. This warranty excludes surface corrosion, scratches, and discoloration which may occur during normal use. This warranty is limited to the replacement of the defective parts, with the owner paying all other cost including labor, shipping and handling.

## II. Limited Five-Year Warranty

The following grill parts are warranted to be free from defects in material and workmanship, when subjected to normal domestic use and service, for a period of five (5) years from the original date of purchase; warming racks, spit rods, manifolds and gas valves. This warranty is limited to the replacement of the defective parts, with the owner paying all other costs including labor, shipping, and handling.

## III. Limited two-Year Warranty

All other grill components, including the computer (CPU), are warranted to be free from defects in material and workmanship, when subjected to normal domestic use and service, for a period of two (2) years from the original date of purchase. This warranty is limited to the replacement of the defective parts, with the owner paying all other costs including labor, shipping and handling.

## IV. Limited One-Year Warranty

For a period of one (1) year from the original date of purchase, Lynx will replace or repair parts found to be defective at no cost to the original purchaser. This includes the cost of shipping replacement parts and, where necessary, service labor at prevailing local rates by a Lynx authorized service person. Service will be provided during normal business hours and must be authorized in advance by Lynx.

## V. Limitations & Exclusions

- 1) This Warranty shall apply to products purchased and located in the United States and Canada. Products must be purchased in the country where service is requested.
- 2) Warranty applies only to the original purchaser and may not be transferred.
- 3) Warranty is in lieu of all other warranties expressed or implied and all other obligations or liabilities related to the sale or use of its grill products.
- 4) Warranty shall not apply and Lynx is not responsible for damage resulting from misuse, abuse, alteration of or tampering with the appliance or computer box, accident,

hostile environment, flare-up fires, improper installation, or installation not in accordance with the instructions contained in this manual, or the local codes.

- 5) Lynx shall not be liable for incidental, consequential, special or contingent damages resulting from its breach of this written warranty or any implied warranty.
  - 6) Some states do not allow limitations on how long an implied warranty lasts, or the exclusions of or limitations on consequential damages. This warranty gives you specific legal rights and you may have other rights which vary from state to state.
  - 7) No one has the authority to add to or vary Lynx's warranty, or to create for Lynx any other obligation or liability in connection with the sale or use of its products.
  - 8) Limited to the replacement of defective parts with the owner paying all other costs including labor.
- VI. What is not covered: Lynx shall not be responsible for and shall not pay for the following
- 1) Installation or start-up, damages or problems caused by improper installation or use;
  - 2) Service by an unauthorized service provider;
  - 3) Damage or repair due to service by an unauthorized service provider or use of unauthorized parts;
  - 4) Warranty does not apply to products installed in any commercial or non-residential application. Examples of excluded applications include, but are not limited to day care centers, schools, bed and breakfast centers, churches, private clubs, fire stations, club houses, common areas in multi-family dwellings, restaurants, hotels, nursing homes, food service locations and institutional food service locations.
  - 5) To correct normal adjustments or settings, due to improper installation, commissioning or local gas supply properties.
  - 6) Shipping and handling costs, export duties, installation, removal, or re-installation cost.
  - 7) Display models are sold "as is". If you have purchased a display model, please be advised that it is sold "as is" and that it is subject to the following warranty exclusions: any exterior or cosmetic damage is nonwarrantable; any missing components will be replaced at consumers expense; major handling damage to manifold, valve and ignition system will be serviced at consumer's expense; all other warranty's (standard warranty) will remain in effect.
  - 8) The cost of a service call to diagnose trouble.

# WIRING DIAGRAMS

## 30 INCH, ELECTRICAL DIAGRAM, SMART GRILL

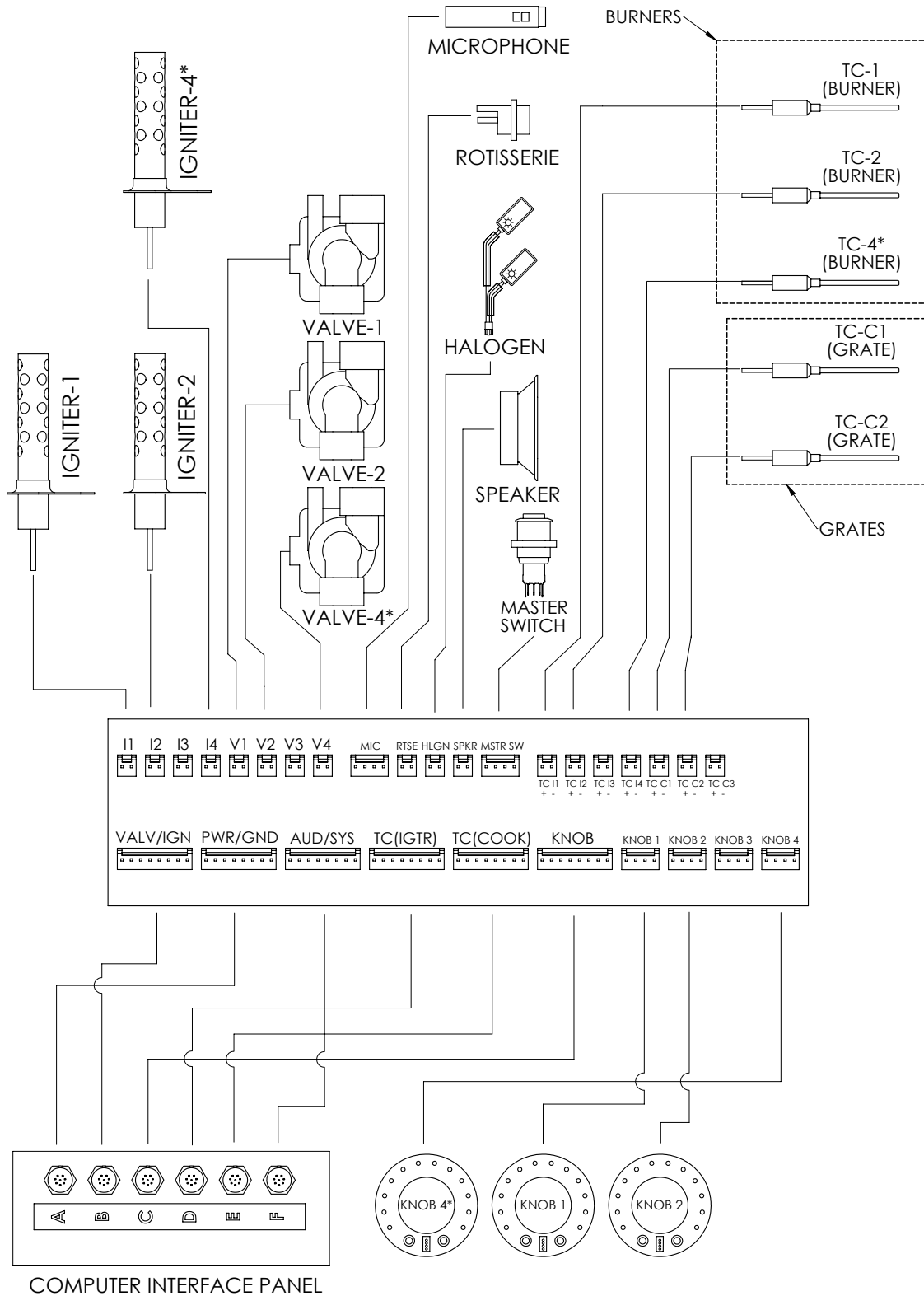

\*NOTE: IGNITER 4, VALVE 4, THERMOCOUPLE 4, AND KNOB 4 ARE ALL FOR THE ROTISSERIE.

# WIRING DIAGRAMS

## 36 INCH AND 42 INCH, ELECTRICAL DIAGRAM, SMART GRILL

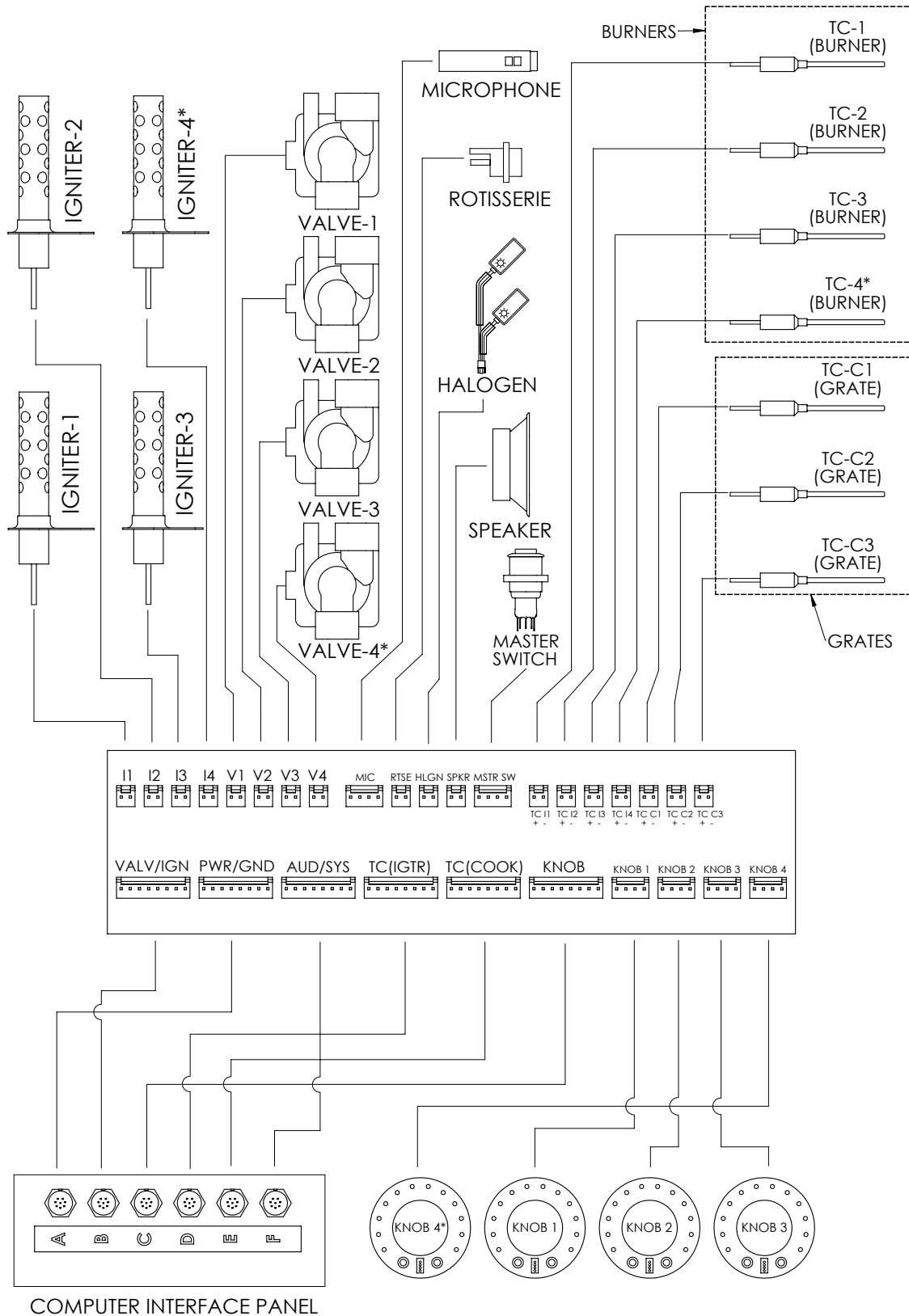

\*NOTE: IGNITER 4, VALVE 4, THERMALCOUPLE 4, AND KNOB 4 ARE ALL FOR THE ROTISSERIE.

# EXPLODED PARTS DIAGRAMS

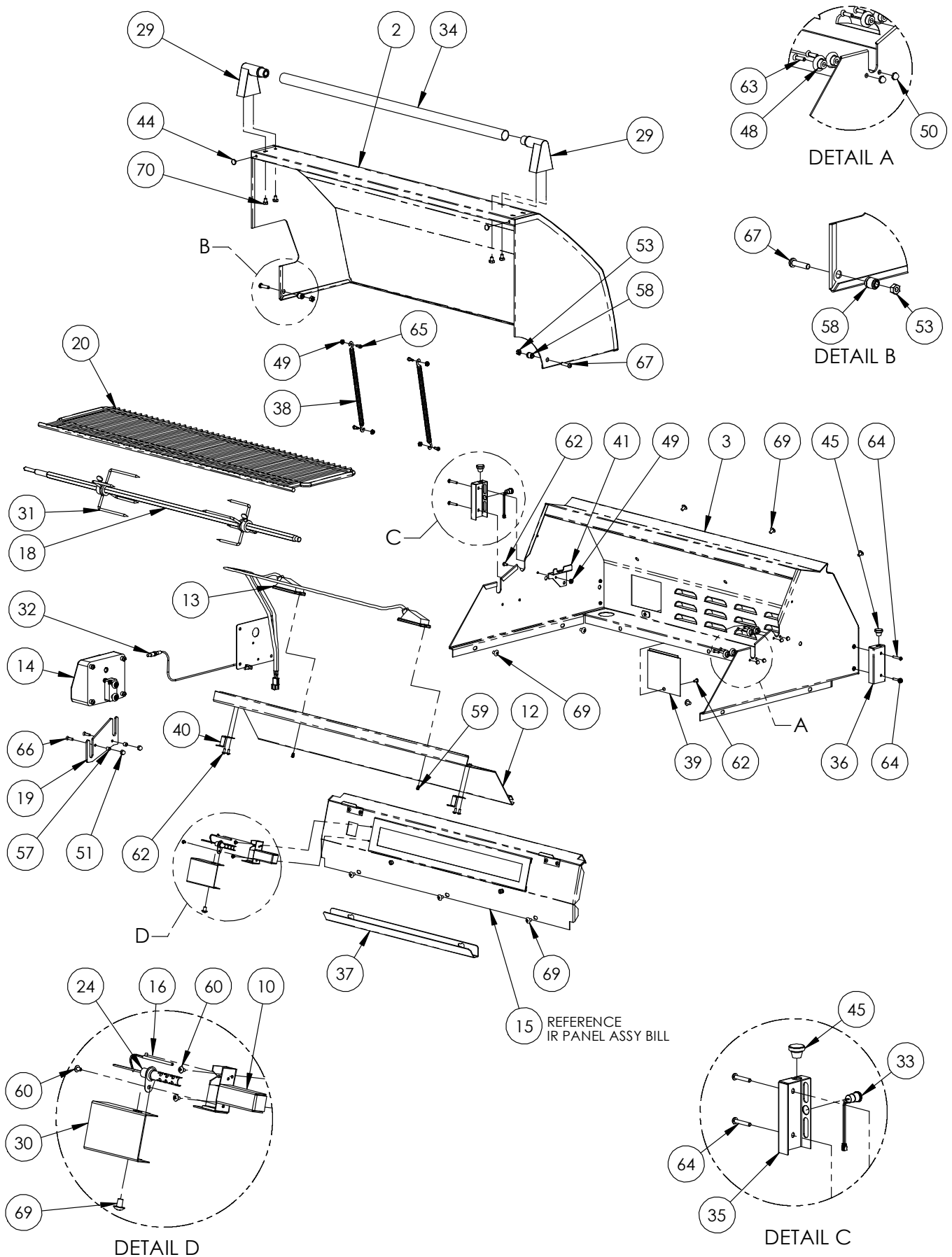

# EXPLODED PARTS DIAGRAMS

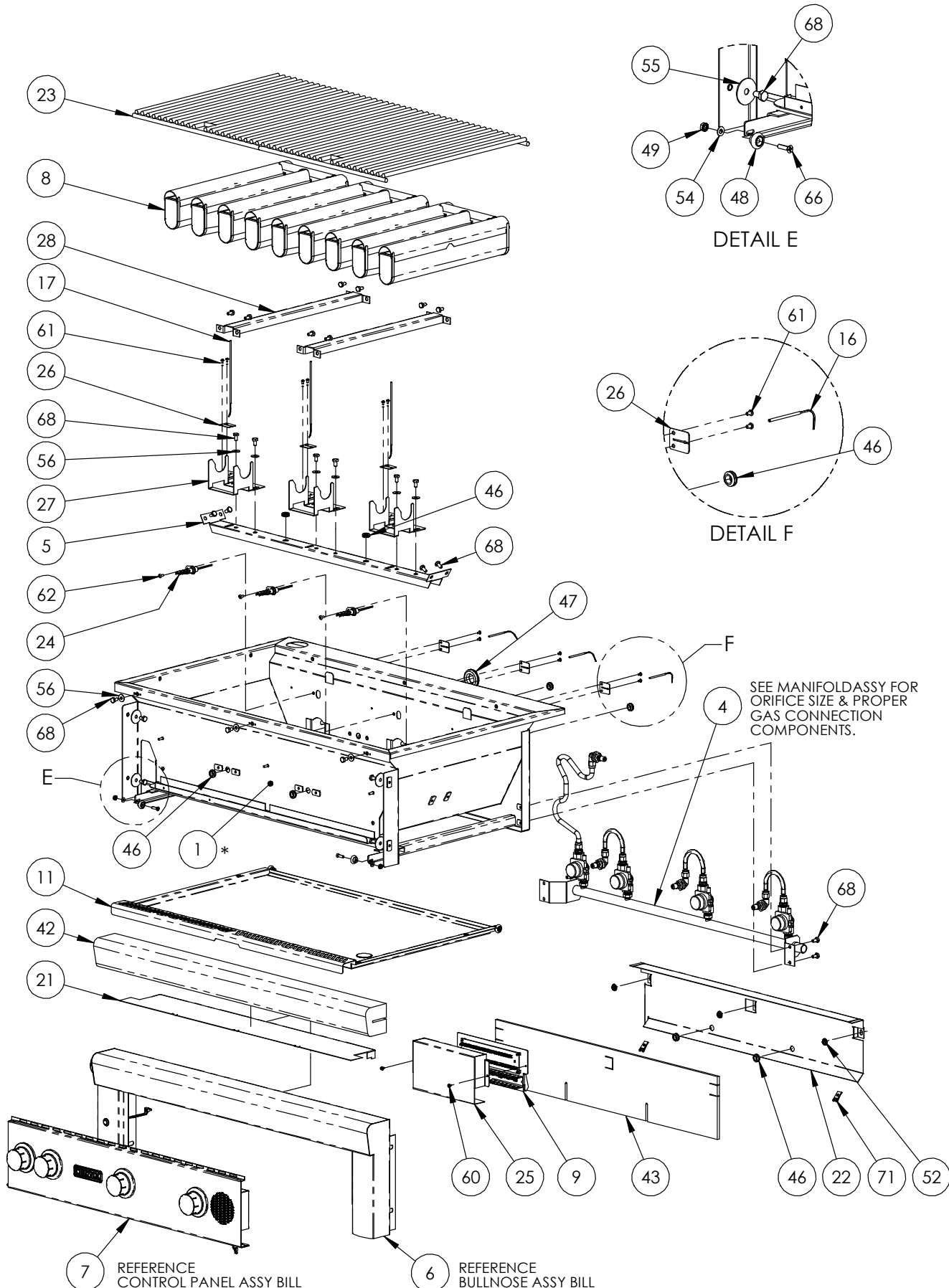

# PARTS LIST

			30"	36"	42"				30"	36"	42"			
*	1	70302	FIREBOX, 30" SG, WELDMNT	1			24	33052	IGNITER, HOT SURFACE (SHORT)	3	4	4		
*		70303	FIREBOX, 36" SG, WELDMNT		1		25	35292	COVER, BREAKOUT BOARD	1	1	1		
*		70304	FIREBOX, 42" SG, WELDMNT			1	26	35369	TC RETAINER CLIP	4	6	6		
	2	70357	FRONT HOOD, 30", SG, WLDMT	1			27	35100	BRACKET, HOLDER, BURNER, SG	2	3	3		
		70358	FRONT HOOD, 36", SG, WLDMT		1		28	31692	STIFFENER, FIREBOX, 30/42	1		2		
		70359	FRONT HOOD, 42", SG, WLDMT			1		35371	STIFFENER, FIREBOX, 36		2			
	3	80269	REAR HOOD, WELD ASSY, 30"	1			29	31736	END CAP, HOOD HANDLE, W/INSUL	2	2	2		
		80270	REAR HOOD, WELD ASSY, 36"		1		30	33136	IR IGNITER COVER	1	1	1		
		80271	REAR HOOD, WELD ASSY, 42"			1	31	31563	FORK, ROTISSERIE	2	2	2		
	4	80922	MANIFOLD, 30, SG, ASSY	1			32	33416	ROTIS POWER CORD	1	1	1		
		80923	MANIFOLD, 36, SG, ASSY		1		33	80440	ROTIS JACK WIRE HARNESS	1	1	1		
		80924	MANIFOLD, 42, SG, ASSY			1	34	32522	HOOD HANDLE, 30" PRO	1				
	5	70331	BRACE, BURNER, 30" SG, WLDMT	1				32523	HOOD HANDLE, 36" PRO		1			
		70332	BRACE, BURNER, 36" SG, WLDMT		1			32524	HOOD HANDLE, 42" PRO			1		
		70333	BRACE, BURNER, 42" SG, WLDMT			1	35	33389	HOOD STOP, W/ROTIS	1	1	1		
	6	80927	BULLNOSE, 30, SG, ASSY	1			36	32468	HOOD STOP	1	1	1		
		80928	BULLNOSE, 36, SG, ASSY		1		37	10158	WOODCHIP TRAY, LARGE	1	1	1		
		80929	BULLNOSE, 42, SG, ASSY			1	38	31874	EXTENSION SPRING W/HOOKS	2		2		
	7	80919	PANEL, CONTROL, 30", ASSY	1				31780	EXTENSION SPRING W/HOOKS		2			
		80920	PANEL, CONTROL, 36", ASSY		1		39	30417	COVER, IR ACCESS	1	1	1		
		80921	PANEL, CONTROL, 42", ASSY			1	40	33033	FRONT RETAINING BRACKET, RACK	2	2	2		
	8	33415	BURNER, PS2, 30, 42, 54	2		3	41	33597	BRACKET, RETAIN, WARMING RACK, LH	1	1	1		
		33478	BURNER, IR MAIN, PROSEAR2		3		42	20021	INSULATION	1	1	1		
	9	80951	BREAKOUT BOARD, 30, ASSY	1			43	35410	INSULATION, DIE-CUT, 30"	1				
		80952	BREAKOUT BOARD, 36/42, ASSY		1	1		35411	INSULATION, DIE-CUT, 36"		1			
	10	70365	IR IGNITER BRACKET WLDMT	1				35412	INSULATION, DIE-CUT, 42"			1		
		80966	DRIP PAN, SMART GRILL, 30" ASSY	1			44	32477	BUMPER, 1/2" DIA, RUBBER, PRESS IN	2	2	2		
		80967	DRIP PAN, SMART GRILL, 36" ASSY		1		45	32470	BUMPER, 3/4, RUBBER, PRESS IN	2	2	2		
		80968	DRIP PAN, SMART GRILL, 42" ASSY			1	46	35310	GROMMET, RBR, 3/8 ID, HI-TEMP	6	8	8		
	12	32156	REAR HOOD LINER, 30"	1			47	33984	GROMMET, RBR, 1 I.D. X 1 3/8 O.D.	1	1	1		
		32441	REAR HOOD LINER, 36"		1		48	20055	WHEEL, BALL BEARING, SS	6	6	6		
		32442	REAR HOOD LINER, 42"			1	49	14024	NUT, #8-32, LOCK TOOTH WASHER, STEEL	7	7	7		
	13	80446	SINGLE LIGHT ASSEMBLY	1			50	31805	NUT, #8-32, ACORN, SS	4	4	4		
		80447	DUAL LIGHT ASSEMBLY		1	1	51	32196	NUT, #10-24, ACORN, SS	2	2	2		
	14	80971	ROTISS MOTOR ASSEMBLY	1	1	1	52	14023	NUT, #10-40, SPEED, STEEL	3	3	3		
	15	80273	INFRARED PANEL ASSY 30"	1			53	L14009	NUT, 1/4-20, HEX, SS	2	2	2		
		80274	INFRARED PANEL ASSY 36"		1		54	32987	WASHER, #10, FLT, SS	2	2	2		
		80275	INFRARED PANEL ASSY 40"			1	55	31317	WASHER, 1/4, FLAT, SS, 1-1/4 O.D.	4	4	4		
	16	35302	THERMOCOUPLE, BURNER, 2"	3	4	4	56	14044	WASHER, 1/4, FLT, SS, 11/16 O.D.	7	9	9		
	17	35026	THERMOCOUPLE, GRATES, 6"	2	3	3	57	32939	SPACER, #10 NOM, 5/16 OD X 9/32, SS	2	2	2		
	18	32128	SPIT ROD, 30"	1			58	34510	HOOD SPACER, UNIVERSAL	2	2	2		
		32129	SPIT ROD, 36"		1		59	30617	SCREW, #6-32 X 1/4, FIP, STEEL	2	2	2		
		32130	SPIT ROD, 42"			1	60	34035	SCREW, #6-32 X 1/4, THP, SS	11	13	13		
	19	32940	BRACKET, MOUNT, ROTIS MOTOR	1			61	14018	SCREW, #6-32 X 1/4, PHP, SS	4	6	6		
	20	32109	WARMING RACK, 30" PRO	1			62	14014	SCREW, #8-32 X 1/2, THP, SS	8	9	9		
		32110	WARMING RACK, 36" PRO		1		63	31804	SCREW, #8-32 X 5/8, FHP, STEEL	4	4	4		
		32111	WARMING RACK, 42" PRO			1	64	32469	SCREW, #8-32 X 1, THP, SS	4	4	4		
	21	35359	HEAT SHIELD, BULLNOSE, 30	1			65	31782	SCREW, SHLDR, #8-32 X 3/16, SLTD, SS	4	4	4		
		35360	HEAT SHIELD, BULLNOSE, 36		1		66	14099	SCREW, #10-24 X 3/4, FHP, SS	4	4	4		
		35361	HEAT SHIELD, BULLNOSE, 42			1	67	14013	SCREW, 1/4-20 X 1, BHS, STEEL	2	2	2		
	22	35356	HEAT SHIELD, FIREBOX, FRONT, 30	1			68	14030	SCREW, 1/4-20 X 1/2, HHD, SS	23	29	29		
		35357	HEAT SHIELD, FIREBOX, FRONT, 36		1		69	14012	SCREW, 1/4-20 X 3/8, THP, STEEL	11	11	11		
		35358	HEAT SHIELD, FIREBOX, FRONT, 42			1	70	31930	SCREW, 1/4-20 X 3/8, HHD, SS	4	4	4		
	23	30018	GRATE PROFESSIONAL, 30/42/54	2		2	71	35424	CLIP, PANEL, #10	AR	AR	AR		
		17020	GRATE PROFESSIONAL, 16-1/2 X 18 1/2			2								
		30019	GREAT PROFESSIONAL, 42/54			1								
			<b>* ITEM IS NOT FIELD REPLACABLE</b>											



# EXPLODED PARTS DIAGRAMS AND PARTS LIST

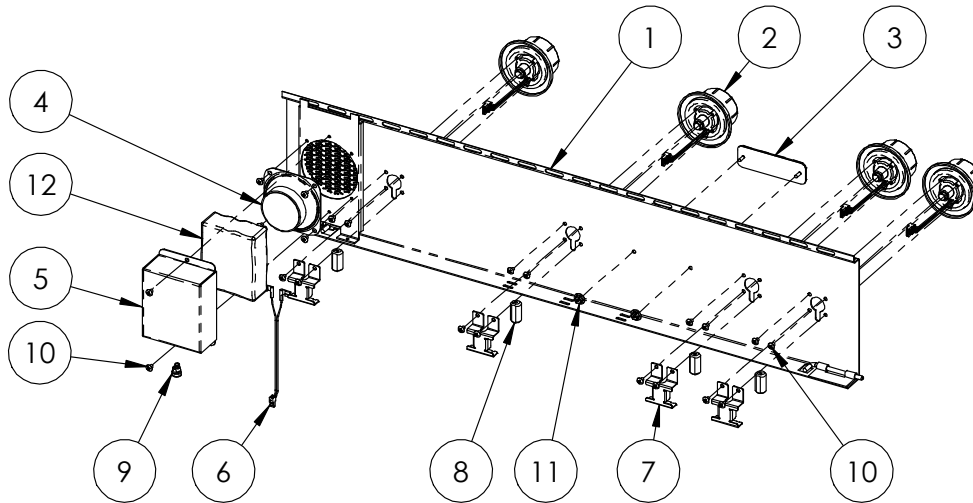

CONTROL PANEL ASSEMBLY						
ITEM	P/N	DESCRIPTION	GRILL SIZE			
			30"	36"	42"	
1	70308	PANEL, CONTROL, 36" , WLDMT	1			
	70309	PANEL, CONTROL, 36" , WLDMT		1		
	70310	PANEL, CONTROL, 36" , WLDMT			1	
2	80925	KNOB, ILLUMINATED, SG, ASSY	3	4	4	* SEE BELOW
3	L11074	LYNX LOGO	1	1	1	
4	35062	SPEAKER, 3.3", 8ohm	1	1	1	
5	35367	COVER, SPEAKER	1	1	1	
6	35262	HARNESS, WIRE, SPEAKER PERIPHERAL	1	1	1	
7	35365	MTG BRACKET, FERRITE, SG	3	4	4	
8	35349	FERRITE, CLAMP ON,, .138" I.D.	3	4	4	
9	35390	CORD GRIP, SNAP-IN, .13-.19 CABLE	1	1	1	
10	34035	SCREW, #6-32 X 1/4, THP, SS	18	22	22	
11	31062	NUT, 1/8, SPEED, STEEL, SELF THREADING	2	2	2	
12	20021	INSULATION	1	1	1	

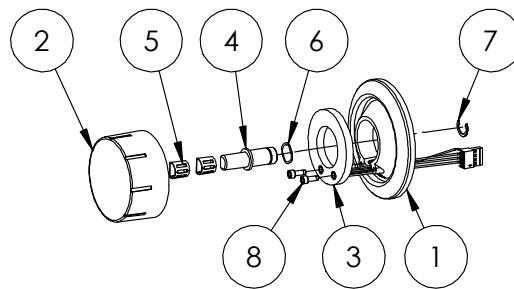

* ILLUMINATED KNOB ASSEMBLY						
ITEM	P/N	DESCRIPTION				
1	35034	BEZEL, KNOB, ILLUMINATED		1		
2	80964	KNOB, BONDED, ASSY		1		
3	35060	PCB, KNOB		1		
4	35037	KNOB, SHAFT		1		
5	33018	CLIP, KNOB		2		
6	35067	SPRING, WAVE, DISC		1		
7	35068	C-CLIP, RETAINER		1		
8	35389	SCREW, #4-40 X 5/16, SHC, SS		2		

# EXPLODED PARTS DIAGRAMS AND PARTS LIST

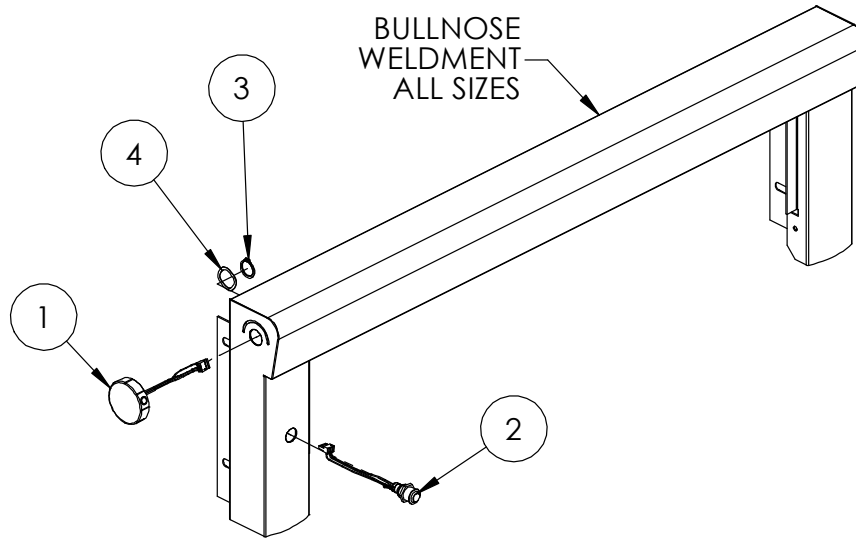

BULLNOSE ASSEMBLY			
NO.	P/N	DESCRIPTION	QTY.
1	80926	MICROPHONE DIAL ASSY	1
2	80953	SWITCH, PUSH-BUTTON, ASSY	1
3	35064	RTN RING, EXT, 3/8" SHAFT	1
4	35141	SPRING, WAVE, DISC,	1

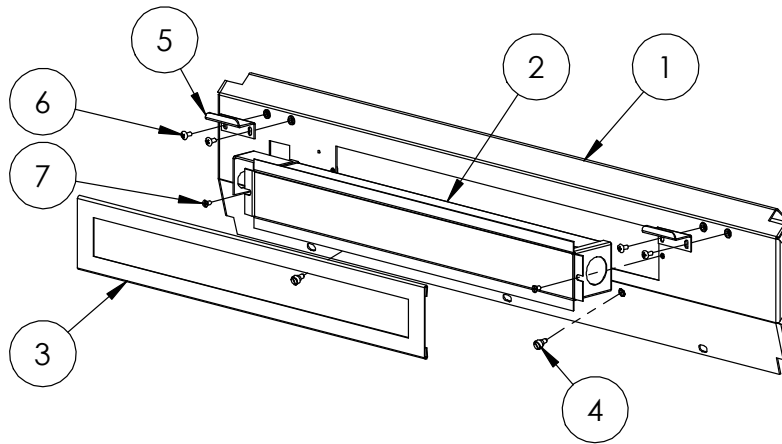

INFRARED PANEL ASSEMBLY					
ITEM	P/N	DESCRIPTION	GRILL SIZE		
			30"	36"	42"
1	80843	IR PANEL WELDMENT, L30	1		
	80842	IR PANEL WELDMENT, L36		1	
	80841	IR PANEL WELDMENT, L42			1
2	32989	IR BURNER, MEDIUM	1	1	
	32990	IR BURNER, LARGE			1
3	32992	COVER TRIM, IR BURNER, MEDIUM	1	1	
	32993	COVER TRIM, IR BURNER, LARGE			1
4	32222	SCREW, SHLDR, #10-32 X 1/4, SLTD, SS		2	
5	32133	REAR RETAINING BRACKET, WR		2	
6	14014	SCREW, #8-32 X 1/2, THP, SS		4	
7	32644	SCREW, #8-32 X 5/16, FHP, SS		2	

# EXPLODED PARTS DIAGRAMS AND PARTS LIST

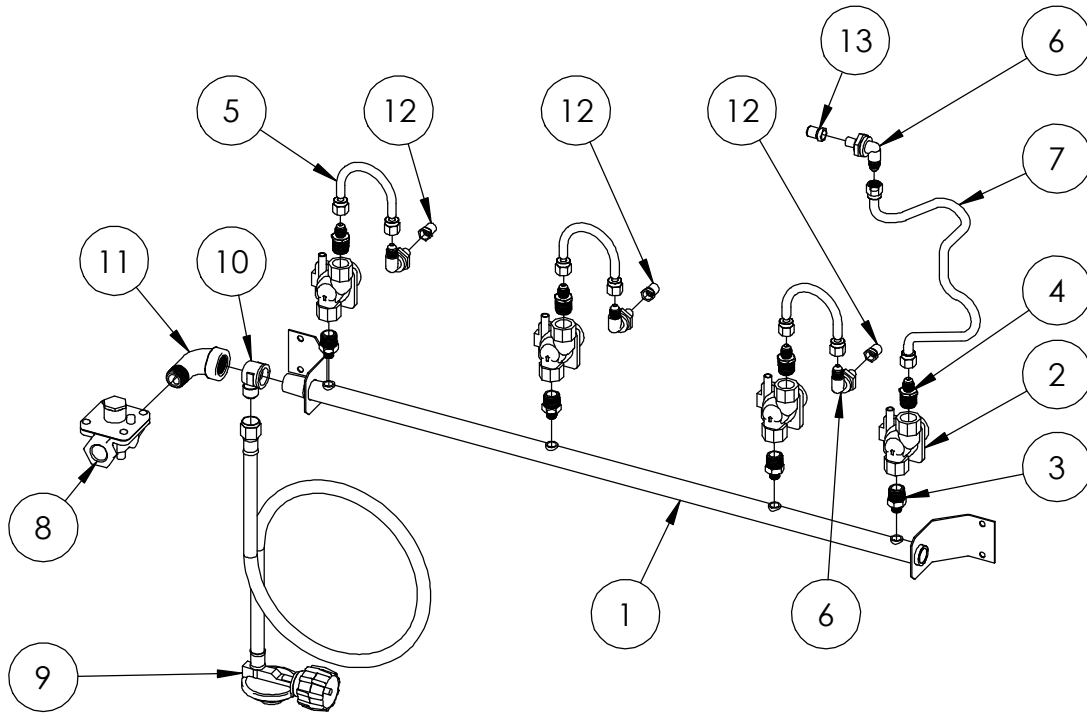

MANIFOLD ASSEMBLY					
ITEM	P/N	DESCRIPTION	GRILL SIZE		
			30"	36"	42"
1	70311	MANIFOLD, 30" SG, WLDMT	1		
	70312	MANIFOLD, 36" SG, WLDMT		1	
	70313	MANIFOLD, 42" SG, WLDMT			1
2	35065	VALVE, ELEC, MODULATING	3	4	4
3	35147	FTNG, NIP, REDUC, 3/8 X 1/8 NFTP	3	4	4
4	35146	FTNG, FLARED, STRAIGHT ADAP	3	4	4
5	35222	FLEX HOSE, 1/4" X 7", SS, 45 DEG. FTF	2	3	3
6	31795	FTNG, ELBOW 90 DEG. 1/4" TUBE, BRASS	3	4	4
7	35296	FLEX HOSE, 1/4" X 20", SS, 45 DEG. FTF	1	1	1
NATURAL GAS (NG)					
8	30781	REGULATOR, 4/11	1	1	1
11	13010	ELBOW, PIPE, FEM X MALE, 1/2 NPT, 90	1	1	1
12	13013	ORIFICE, #41	2	3	3
13	13016	ORIFICE, #50	1	1	1
LIQUID PROPANE (LP)					
9	13026	LP REGULATOR W/36" HOSE	1	1	1
10	13054	ELBOW, 3/8" FLARE TO 1/2" FIP	1	1	1
12	13018	ORIFICE, #52	2	3	3
13	13021	ORIFICE, #57	1	1	1

## MODEL-SPECIFIC BTU OUTPUTS & MAX. RUNS FOR APPLIANCES

MODEL-SPECIFIC BTU OUTPUTS			
MODEL	ROTISSERIE	PROSEAR™ 2	TOTAL INPUT
SMART30(F)	1 @ 14,000	2 @ 23,000	60,000 Btu/Hr
SMART36(F)	1 @ 14,000	3 @ 23,000	83,000 Btu/Hr
SMART42(F)	1 @ 16,000	3 @ 23,000	85,000 Btu/Hr

MAXIMUM RUNS FOR ALL APPLIANCES ON SUPPLY LINE	
Run Length 3/4" Pipe (in feet)	Max BTU for all Appliances on line
10	360,000
20	245,000
30	198,000
40	169,000
50	150,000
60	135,000
70	123,000
80	115,000

NOTE: IF A 1/2 INCH LINE IS USED WITH NATURAL GAS IT SHOULD BE NO LONGER THAN 12 FEET.

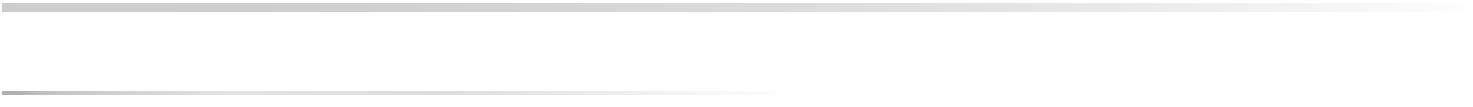

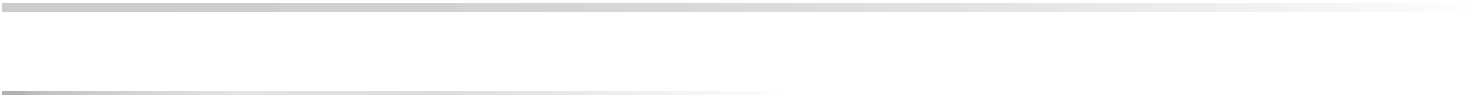

# INDEX

<b>#</b>	
4/11 Regulator .....	16
<b>B</b>	
Before Each Use .....	23
Before You Start .....	10
BTU Outputs, Model Specific .....	38
Burner Placement .....	30
<b>C</b>	
Checklist Before Each Use .....	23
Calibrating Your SmartGrill .....	4, 22
Cleaning Your SmartGrill .....	29
Clearance to Combustibles .....	11
Contacting LYNX .....	33
Cut-out Dim., Built-in Grills .....	13
<b>D</b>	
Damage:	
Concealed .....	10
Visible .....	10
Direct Heat Cooking .....	28
Drip Tray .....	29
Downloading Your SmartGrill by Lynx™ App .....	21
<b>E</b>	
Electrical Connections .....	18
Exploded Parts View .....	38
<b>F</b>	
Factory Reset .....	31
Final Checks .....	19
<b>G</b>	
Gas Connections .....	15
Gas Requirements .....	15
Gas Supply Line Runs .....	38
Grilling in Windy Conditions .....	9
<b>I</b>	
Indirect Heat Cooking .....	28
Important Safety Precautions .....	8
<b>L</b>	
Leak Test Procedure .....	19
Lighting Your Grill .....	23
LP Cylinder Requirements .....	16
LP Gas .....	16
<b>M</b>	
Maximum Runs for all appliances on supply line .....	38
Message from Lynx .....	7
<b>N</b>	
Natural Gas .....	15
<b>O</b>	
Obtaining Service from LYNX .....	34
<b>P</b>	
Parts List .....	41
Parts View, Exploded .....	38
Pre-Grill Checklist .....	22
Purging the Gas Line (See Calibrating Your SmartGrill) .....	4, 22
<b>R</b>	
Recipe Database .....	26
Regulator Conversion .....	16
Rotisserie, Using the .....	26, 27
<b>S</b>	
Security Code Lock .....	22
Service, contacting LYNX .....	34
Side Burner Connections .....	17
<b>T</b>	
Technical Assistance .....	34
Troubleshooting .....	30
<b>U</b>	
Unpacking .....	10
<b>V</b>	
Voice Commands .....	25
<b>W</b>	
Warranty .....	35
Windy Conditions, Grilling in .....	9
Wiring Diagrams .....	36



## MOM FRIENDLY. DAD READY.™

The best outdoor kitchen products come from:  
Lynx Grills, Inc.  
7300 Flores Street  
Downey, CA 90242

For more information please call,  
**1-888-289-5969** or visit [www.lynxgrills.com](http://www.lynxgrills.com)

P/N 35014 01/2015 ©Lynx Grills



Voted "Most Coveted Product" by the  
Consumer Electronics Association staff  
at the 2014 Consumer Electronics Show

