

This Owner's Manual is provided and hosted by [Appliance Factory Parts](#).



Napoleon NT13A030B Owner's Manual

[Shop genuine replacement parts for Napoleon
NT13A030B](#)



[Find Your Napoleon HVAC Parts - Select From 105 Models](#)

----- Manual continues below -----

INSPECT THE SHIPPING CONTAINER IMMEDIATELY UPON RECEIVING YOUR UNIT. ANY DAMAGE SHOULD BE NOTED ON FREIGHT BILL BEFORE SIGNING AND CLAIMS SHOULD BE FILLED WITH CARRIER AS SOON AS POSSIBLE. MAKE SURE THAT RATING PLATE MATCHES THE MODEL NUMBER YOU PURCHASED.



INSTALLER: PLEASE FAMILIARIZE YOURSELF WITH THIS MANUAL BEFORE PROCEEDING WITH THE INSTALLATION. LEAVE THIS MANUAL WITH THE APPLIANCE FOR FUTURE REFERENCE.
CONSUMER: RETAIN THIS MANUAL FOR FUTURE REFERENCE.

INSTALLATION AND OPERATING INSTRUCTIONS

13, 14 & 16 SEER SPLIT SYSTEM AIR CONDITIONERS

Conforms to UL Standard 1995. Certified to CAN/CSA Standard C22.2 No.236.



⚠ WARNING ⚠

ELECTRICAL SHOCK, FIRE OR EXPLOSION HAZARD

FAILURE TO FOLLOW SAFETY WARNINGS AND INSTRUCTIONS EXACTLY COULD RESULT IN SERIOUS INJURY, DEATH OR PROPERTY DAMAGE.

THIS INFORMATION IS INTENDED FOR USE BY QUALIFIED HVAC TECHNICIANS POSSESSING ADEQUATE BACKGROUNDS OF ELECTRICAL AND MECHANICAL EXPERIENCE. ANY ATTEMPT TO REPAIR A CENTRAL AIR CONDITIONING PRODUCT MAY RESULT IN PERSONAL INJURY AND/OR PROPERTY DAMAGE.

THE MANUFACTURER OR SELLER CANNOT BE RESPONSIBLE FOR THE INTERPRETATION OF THIS INFORMATION, NOR CAN IT ASSUME ANY LIABILITY IN CONNECTION WITH ITS USE.

UNIT CONTAINS R-410A REFRIGERANT AND POE COMPRESSOR OIL! USE ONLY R-410A REFRIGERANT AND APPROVED POE COMPRESSOR OIL. REFRIGERANT LINES MUST BE BRAZED AND RATED FOR R410 PRESSURES!

PROPER SERVICE EQUIPMENT IS REQUIRED. USE ONLY R-410A APPROVED SERVICE EQUIPMENT. FAILURE TO USE PROPER SERVICE TOOLS MAY RESULT IN EQUIPMENT DAMAGE OR PERSONAL INJURY.

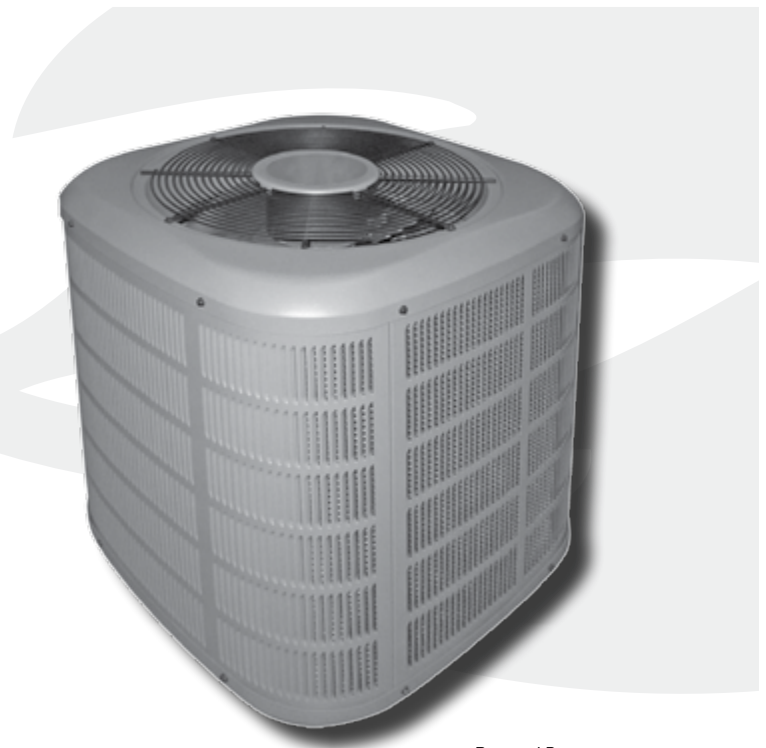

Powered By:
Copeland
brand products

Congratulations on the purchase of your Napoleon Air Conditioner. Napoleon's line of Split Air Conditioners offer industry leading quality and are equipped with multiple advanced features:

FEATURES:

- 13, 14 & 16 SEER efficiencies
- Capacities from 1.5 ton to 5.0 tons
- Utilizes environmentally friendly R-410A refrigerant
- High Efficiency Copeland Scroll Compressors
- Micro Channel Condenser
- Swept Fan Blades

MANUFACTURER RESERVES THE RIGHT TO DISCONTINUE, OR CHANGE AT ANY TIME, SPECIFICATIONS OR DESIGNS WITHOUT NOTICE AND WITHOUT INCURRING OBLIGATIONS.

Wolf Steel Ltd., 24 Napoleon Rd., Barrie, ON, L4M 0G8 Canada /
103 Miller Drive, Crittenden, Kentucky, USA, 41030
Phone 866-820-8686 • Fax 705-725-1150 • www.napoleonheatingandcooling.com •
hvac@napoleonproducts.com

TABLE OF CONTENTS

- 1. **MODEL NOMENCLATURE** 2
- 2. **OVERVIEW** 3
- 3. **SAFETY** 3
 - 3.1 SAFETY SYMBOLS 3
 - 3.2 SAFETY RULES 4
 - 3.3 CODES 5
- 4. **LIMITATIONS** 5
- 5. **LOCATION AND CLEARANCE** 6
 - 5.1 CLEARANCE 6
 - 5.2 LOCATION RESTRICTIONS 6
- 6. **INSTALLATION** 7
 - 6.1 SUPPORT 7
 - 6.2 UNIT PLACEMENT 7
 - 6.3 REFRIGERANT LINE SET INSTALLATION 8
- 7. **EVACUATION** 13
 - 7.1 EVACUATE THE REFRIGERANT LINES AND INDOOR COIL 13
- 8. **SERVICE VALVES** 14
 - 8.1 OPEN THE SERVICE VALVES 14
- 9. **ELECTRICAL** 15
 - 9.1 HIGH VOLTAGE 15
- 10. **START UP** 18
- 11. **SYSTEM CHARGE ADJUSTMENT** 19
 - 11.1 SYSTEM TOTAL CHARGE 19
 - 11.2 ADJUSTING SYSTEM CHARGE FOR SYSTEMS USING THERMOSTATIC EXPANSION VALVES 19
 - 11.3 ADJUSTING SYSTEM CHARGE FOR SYSTEMS USING FIXED ORIFICE 20
 - 11.4 RECORD SYSTEM INFORMATION 20
- 12. **CHECKOUT PROCEDURES** 21
 - 12.1 INSTRUCTING THE OWNER 21
 - 12.2 CHECKOUT PROCEDURE 21
 - 12.3 SYSTEM OPERATION CHECKOUT PROCEDURE 21
- 13. **AIR CONDITIONING TROUBLESHOOTING** 22
- 14. **MAINTENANCE** 24
 - 14.1 INDOOR 24
 - 14.2 OUTDOOR 24
- 15. **OWNER'S SERVICE INFORMATION** 25
- 16. **WARRANTY** 26

SHIPPING INSPECTION: The unit is shipped in one package, completely assembled and wired. Inspect the shipping container immediately upon receiving your unit. If it appears that damage has occurred, it should be noted on the freight bill before signing. Damage claims should be filed with the carrier as quickly as possible. Check the rating plate (at the front of the access panel) to confirm cooling capacities. The unit **MUST** be operated only with the type of refrigerant, oil and electrical supply noted on the rating plate.

1. MODEL NOMENCLATURE

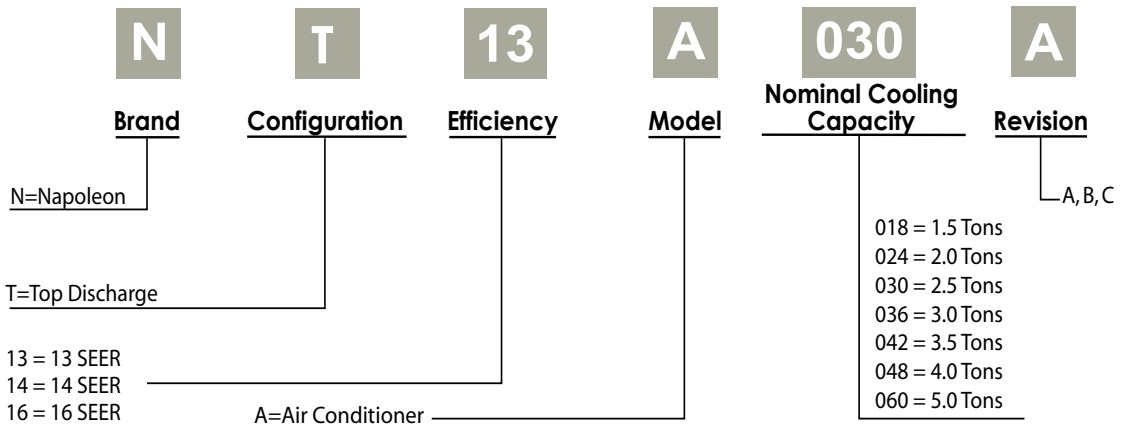

2. OVERVIEW

These instructions cover installation of Napoleon Split System Air Conditioners. Napoleon's line of Split Air Conditioners offer industry leading quality and reliability. All outdoor units have been factory run-tested and ready for easy installation.

Napoleon's line of Split Air Conditioners are designed to perform for many years. These instructions are intended as an aid to the licensed service technician to properly install the unit. Improper installation may damage equipment, void the warranty, and can create a hazard, resulting in property damage, injury or death.

Our air conditioning systems and components are designed to be installed by qualified HVAC technicians ONLY. The installation of air conditioning systems includes electrical and refrigerant connections and is regulated by a multiple sets of laws, codes and guidelines, at the federal, state and local levels. It is the installer's responsibility to install the product in accordance with all applicable codes and regulations. It is the homeowner's responsibility to properly maintain the equipment. NO WARRANTY is offered for the products that were installed by unlicensed/unauthorized persons. Failure to comply with this policy could lead to violations of applicable laws that are punishable.

Documentation and specifications are continuously updated and subject to change. Please download the latest version of specifications and manuals at <http://www.napoleonheatingandcooling.com>.

3. SAFETY

3.1 SAFETY SYMBOLS

Understand and pay particular attention to the words DANGER, WARNING, and CAUTION and the following defined symbols are used throughout this manual to notify the reader of potential hazards of varying risk levels.
⚠ DANGER ⚠
INDICATES AN IMMINENTLY HAZARDOUS SITUATION WHICH, IF NOT AVOIDED, WILL RESULT IN DEATH OR SERIOUS INJURY.
⚠ WARNING ⚠
INDICATES A POTENTIALLY HAZARDOUS SITUATION WHICH, IF NOT AVOIDED, COULD RESULT IN DEATH OR SERIOUS INJURY.
⚠ CAUTION ⚠
INDICATES A POTENTIAL HAZARDOUS SITUATION WHICH, IF NOT AVOIDED, MAY RESULT IN MINOR OR MODERATE INJURY. IT MAY ALSO BE USED TO ALERT AGAINST UNSAFE PRACTICES.
⚠ IMPORTANT ⚠
SUGGESTS IMPORTANT PROCEDURE STEPS TO INSURE PROPER INSTALLATION, RELIABILITY, OR OPERATION.
NOTE
HIGHLIGHTS SUGGESTIONS WHICH WILL RESULT IN ENHANCED INSTALLATION, RELIABILITY, OR OPERATION.

3.2 SAFETY RULES

IMPORTANT:

READ THE FOLLOWING INSTRUCTIONS COMPLETELY BEFORE INSTALLING!

H6.0

⚠ WARNING ⚠

THIS INFORMATION IS INTENDED FOR USE BY QUALIFIED HVAC TECHNICIANS POSSESSING ADEQUATE BACKGROUNDS OF ELECTRICAL AND MECHANICAL EXPERIENCE. ANY ATTEMPT TO REPAIR A CENTRAL AIR CONDITIONING PRODUCT MAY RESULT IN PERSONAL INJURY AND/OR PROPERTY DAMAGE. THE MANUFACTURER OR SELLER CANNOT BE RESPONSIBLE FOR THE INTERPRETATION OF THIS INFORMATION, NOR CAN IT ASSUME ANY LIABILITY IN CONNECTION WITH ITS USE.

⚠ CAUTION ⚠

UNIT CONTAINS R-410A REFRIGERANT AND POE COMPRESSOR OIL.
USE ONLY R-410A REFRIGERANT AND APPROVED POE COMPRESSOR OIL.
REFRIGERANT LINES MUST BE BRAZED AND RATED FOR R410 PRESSURES!
PROPER SERVICE EQUIPMENT IS REQUIRED. USE ONLY R-410A APPROVED SERVICE EQUIPMENT. FAILURE TO USE PROPER SERVICE TOOLS MAY RESULT IN EQUIPMENT DAMAGE OR PERSONAL INJURY.

ALL R-410A SYSTEMS USE POE OIL. POE OIL EASILY ABSORBS MOISTURE FROM THE AIR. A SYSTEM WHICH HAS BEEN EXPOSED TO THE ATMOSPHERE FOR MORE THAN 4 HOURS REQUIRES THAT THE COMPRESSOR OIL BE REPLACED. NEVER BREAK A VACUUM WITH AIR AND ALWAYS CHANGE THE FILTER DRIER WHEN OPENING THE SYSTEM FOR COMPONENT REPLACEMENT.

⚠ WARNING ⚠

HOT SURFACE! DO NOT TOUCH TOP OF COMPRESSOR.
COMPRESSOR AND DISCHARGE PIPES MAY BE EXTREMELY HOT.
IT MAY CAUSE MINOR TO SEVERE BURNING.

⚠ CAUTION ⚠

DURING INSTALLATION, TESTING, SERVICING, AND TROUBLESHOOTING OF THIS PRODUCT, IT MAY BE NECESSARY TO WORK WITH ELECTRICAL COMPONENTS. THERE IS A RISK OF ELECTRIC SHOCK. IT CAN CAUSE INJURY OR DEATH:
DISCONNECT ALL REMOTE ELECTRIC POWER SUPPLIES BEFORE SERVICING!

H3.3 AC

⚠ WARNING ⚠

THESE INSTRUCTIONS ARE INTENDED AS AN AID TO QUALIFIED SERVICE PERSONNEL FOR PROPER INSTALLATION, ADJUSTMENT AND OPERATION OF THIS UNIT. READ THESE INSTRUCTIONS THOROUGHLY BEFORE ATTEMPTING INSTALLATION OR OPERATION. FAILURE TO FOLLOW THESE INSTRUCTIONS MAY RESULT IN IMPROPER INSTALLATION, ADJUSTMENT, SERVICE OR MAINTENANCE, POSSIBLY RESULTING IN FIRE, ELECTRICAL SHOCK, EXPLOSION, PROPERTY DAMAGE, PERSONAL INJURY OR DEATH.

NOTE

USE ONLY AUTHORIZED HVAC PARTS. USE OF OTHER PARTS MAY VOID WARRANTY OR ADVERSELY IMPACT PERFORMANCES.

1. Only trained service technicians familiar with standard service instructions and training materials should attempt installation, service, and repair of these units. Failure to follow these instructions may result in improper installation, adjustment, alteration, service, maintenance, or use that can cause explosion, fire, electrical shock, or other conditions which may cause death, personal injury, or property damage. For information or assistance, consult a qualified installer, service agency, your distributor or branch.
2. Unit contains R-410A refrigerant and POE compressor oil! Use only R-410A refrigerant and approved POE compressor oil. Refrigerant lines must be brazed and rated for R410A pressures!
3. Follow all safety codes.
4. Wear safety glasses, protective clothing, and work gloves.
5. Have fire extinguisher available.
6. Read instructions thoroughly and follow all warnings or cautions included in literature and attached to the unit. Consult federal, provincial, state, and local codes for special requirements.

3.3 CODES

This unit must be installed in accordance with all local codes, by-laws and regulations by those authorities having jurisdiction.

Electrical connections must be made in accordance with:

- a. Canada: current edition of CAN/CSA C22.1 and C22.2, Canadian Electrical Code (Part 1 and 2).
- b. United States: current edition of ANSI/NFPA 70, National Electrical Code.

Codes and additional information may be obtained from:

Canadian Standards Association
5060 Spectrum Way
Mississauga, Ontario, L4W 5N6
Phone: (416) 747-4000
website: www.csa.ca

National Fire Protection Association
1 Batterymarch Park
Quincy, MA, 02169-7471
Phone: (617) 770-3000
website: www.nfpa.org

American Gas Association
400 North Capitol Street, NW,
Suite 450
Washington DC, 20001
Phone: (202) 824-7000
website: www.aga.org

H6.3_AC

4. LIMITATIONS

The unit should be installed in accordance with all National, Provincial/State and Local Safety Codes and the limitations listed below:

1. Limitations for the indoor unit, coil, and appropriate accessories must also be observed.
2. The outdoor unit must not be installed with any duct work in the air stream. The outdoor fan is the propeller type and is not designed to operate against any additional external static pressure.
3. The maximum and minimum conditions for operation must be observed to assure a system that will give maximum performance with minimum service.

Ambient Air Temperature on Outdoor Coil		Air Temperature on Indoor Coil	
Min. DB	Max. DB	Min. WB	Max. WB
50 °F	115 ° F	57 °F	72 °F

TABLE 1.

4. The unit should not be operated at outdoor temperatures below 50° F without an approved low ambient operation accessory kit installed.

5. LOCATION AND CLEARANCE

IOM

5.1 CLEARANCE

The minimum clearances required for installation and accessibility are shown below. These clearances should be followed unless otherwise approved by the manufacturer.

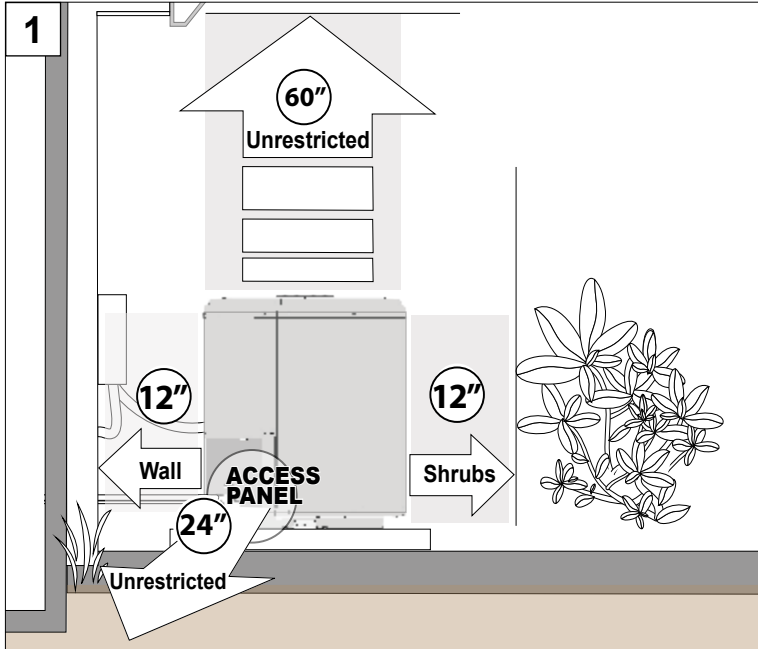

- Ensure the top discharge area is unrestricted for at least 60" above the unit (Figure 1.).
- Clearance must be provided in front of the access panel for servicing and adequate airflow around the cabinet as shown on Fig.1, 2 & 3.
- The distance in between two or more units will be 24" minimum.

5.2 LOCATION RESTRICTIONS

- Do not locate unit close to bedrooms or areas where operational sounds may be objectionable (Fig. 4).
- Outdoor unit location must be far enough away from any structure to prevent excess runoff water from pouring directly on to the unit (Fig. 5). Check with National and Local Codes.

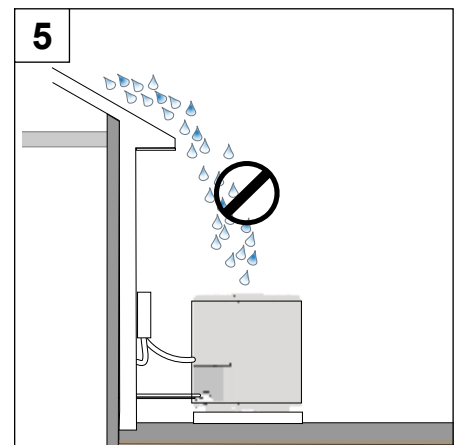
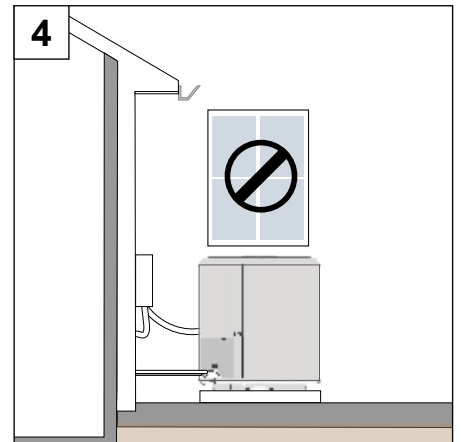
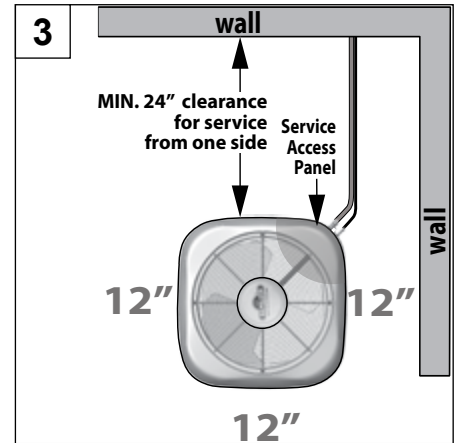
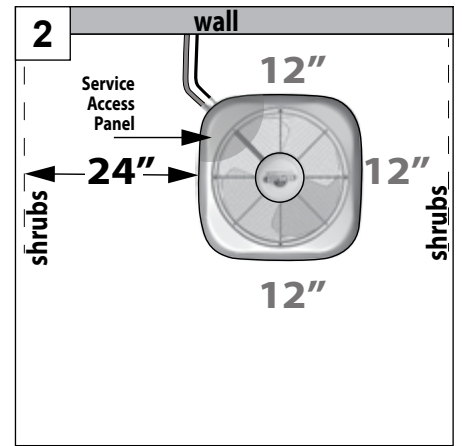

6. INSTALLATION

6.1 SUPPORT

Support pad:

1. The pad must be:
 - a. separate from any structure.
 - b. properly sized according to the size of the cabinet. No portion of the cabinet shall overhang beyond the pad.

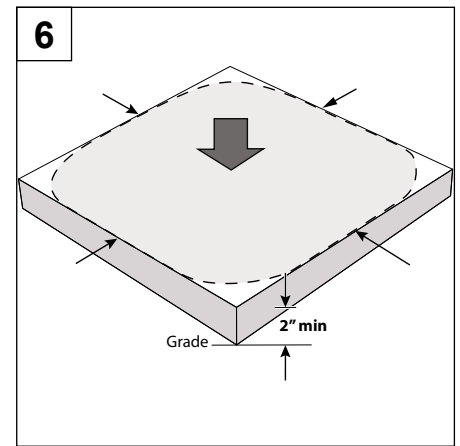

2. The pad must be level (Fig 7). The pad location must comply with National, State, and Local codes.

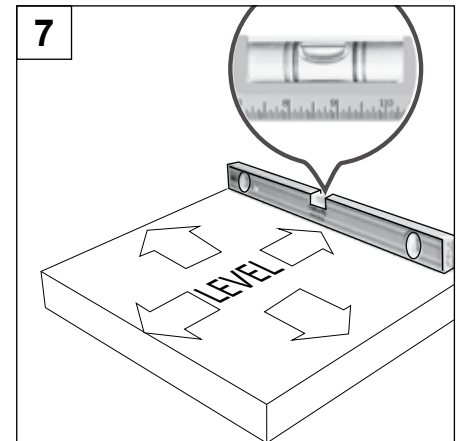

6.2 UNIT PLACEMENT

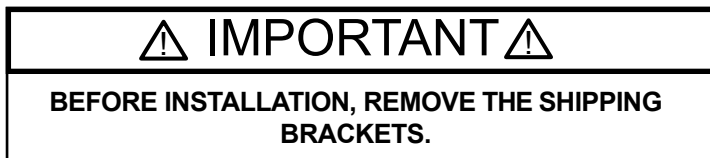

3. Remove screws holding four brackets to the pallet and lift off the clips (Fig 8).

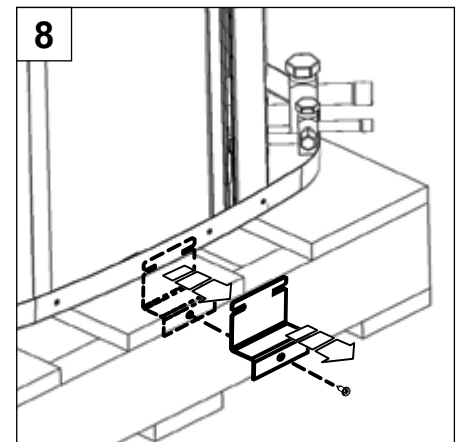

4. Center, position and place the unit onto pad (Fig 9).

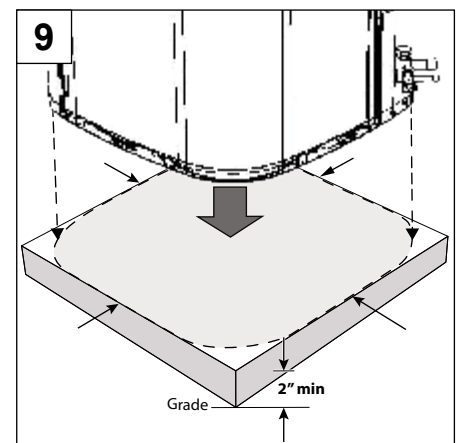

6.3 REFRIGERANT LINE SET INSTALLATION

6.3.1 Refrigerant Piping Limitations

10

- Maximum line length = 100 feet.

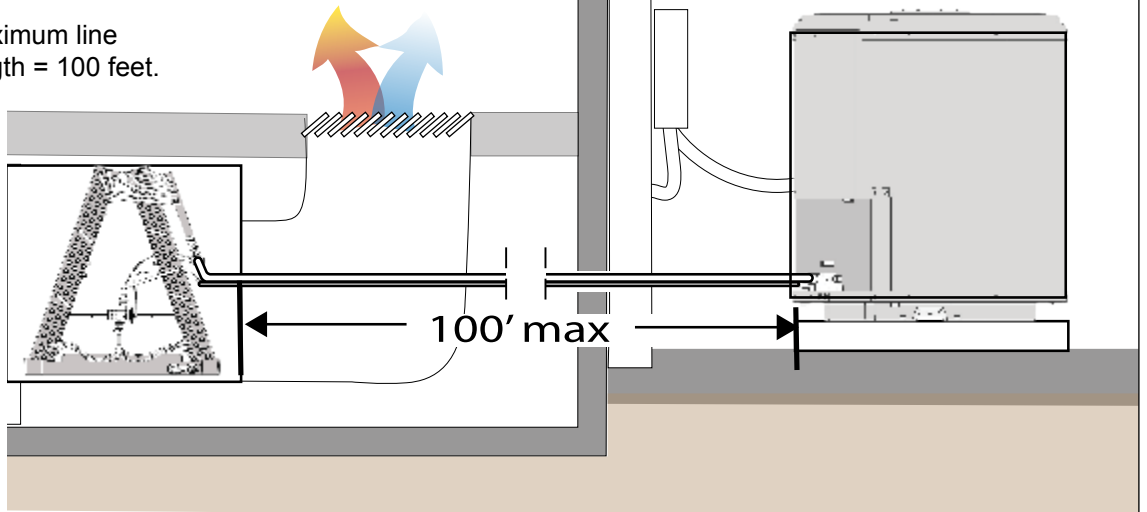

11

- Maximum vertical height = 60 feet.

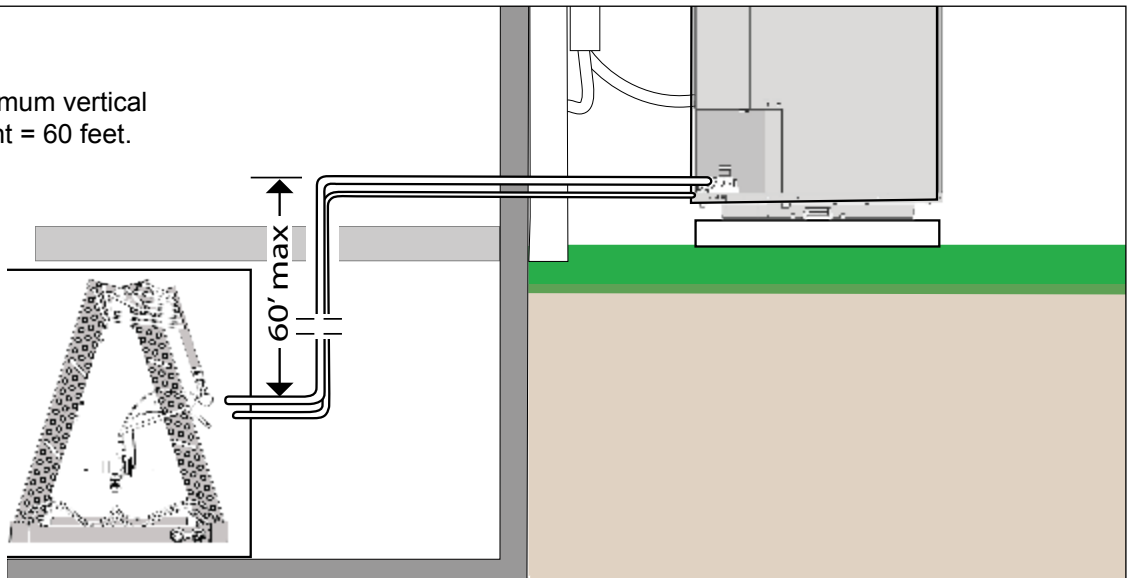

12

- Maximum vertical height = 60 feet.
- Compressor crankcase heater is required for line lengths over 60 feet.
- Use only the line diameters indicated in TABLE 2.

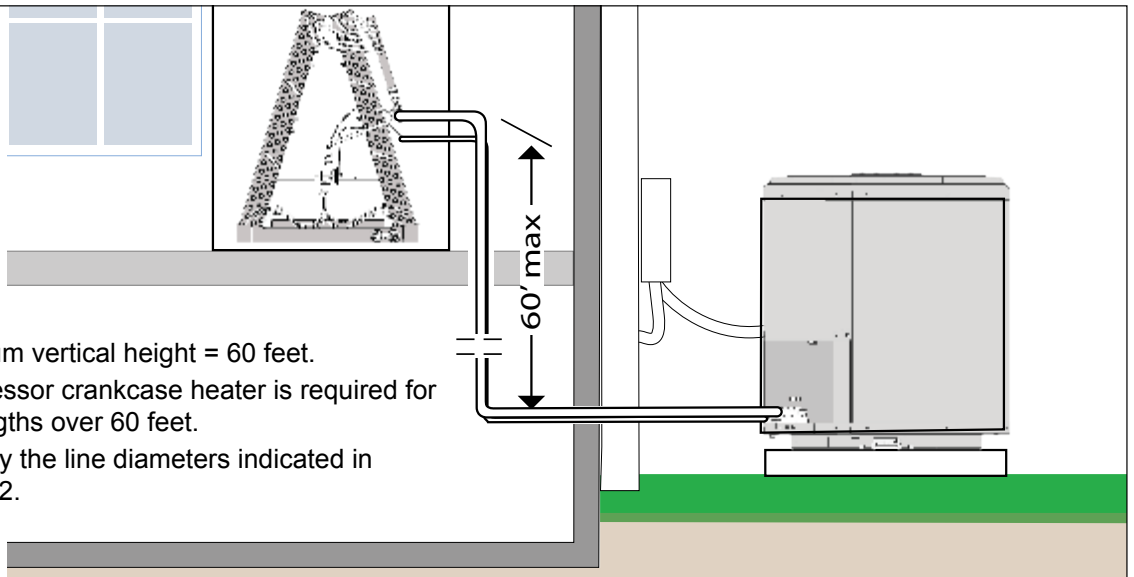

6.3.2 Refrigerant Line and Service Valve Connection Sizes

PIPING CONNECTIONS

The outdoor condensing unit must be connected to the matched indoor evaporator coil using field supplied refrigerant grade (ACR) copper tubing that is internally clean and dry. Units should be installed only with the tubing sizes for approved system combinations as specified in Table 2.

NOTE

- USING A LARGER THAN SPECIFIED LINE SIZE COULD RESULT IN OIL RETURN PROBLEMS.
- USING TOO SMALL A LINE WILL RESULT IN LOSS OF CAPACITY AND OTHER PROBLEMS CAUSED BY INSUFFICIENT REFRIGERANT FLOW.
- SLOPE HORIZONTAL VAPOR LINES AT LEAST 1" EVERY 20 FEET TOWARD THE OUTDOOR UNIT TO FACILITATE PROPER OIL RETURN.

TABLE 2.

MODEL	Line Sizes		Service Valve Connection Sizes	
	Vapor Line	Liquid Line	Vapor Line Connection	Liquid Line Connection
1.5 Tons	3/4	3/8	3/4	3/8
2.0 Tons	3/4	3/8	3/4	3/8
2.5 Tons	3/4	3/8	3/4	3/8
3.0 Tons	3/4	3/8	3/4	3/8
3.5 Tons	7/8	3/8	7/8	3/8
4.0 Tons	7/8	3/8	7/8	3/8
5.0 Tons	7/8	3/8	7/8	3/8

6.3.3 Line Brazing

⚠ WARNING ⚠

REFRIGERANT LINES MUST BE BRAZED AND RATED FOR R410A PRESSURES!

⚠ WARNING ⚠

DO NOT REMOVE SERVICE VALVE CAPS UNTIL SECTION 7.

⚠ CAUTION ⚠

DRY NITROGEN SHOULD ALWAYS BE SUPPLIED THROUGH THE TUBING WHILE IT IS BEING BRAZED, BECAUSE THE TEMPERATURE REQUIRED IS HIGH ENOUGH TO CAUSE OXIDATION OF THE COPPER UNLESS AN INERT ATMOSPHERE IS PROVIDED. THE FLOW OF DRY NITROGEN SHOULD CONTINUE UNTIL THE JOINT HAS COOLED. ALWAYS USE A PRESSURE REGULATOR AND SAFETY VALVE TO INSURE THAT ONLY LOW PRESSURE DRY NITROGEN IS INTRODUCED INTO THE TUBING. ONLY A SMALL FLOW IS NECESSARY TO DISPLACE AIR AND PREVENT OXIDATION.

⚠ WARNING ⚠

NEVER ATTEMPT TO REPAIR ANY BRAZED CONNECTIONS WHILE THE SYSTEM IS UNDER PRESSURE. PERSONAL INJURY COULD RESULT.

1. Remove plastic caps from the service valve connections. Remove the pressure port caps and valve cores from pressure service ports (Fig. 13).
2. Install lines into service valve connections (Fig. 14).
3. Purge the refrigerant line and indoor coil with dry nitrogen (Fig. 15). Continue to purge until whole brazing process is complete.

13

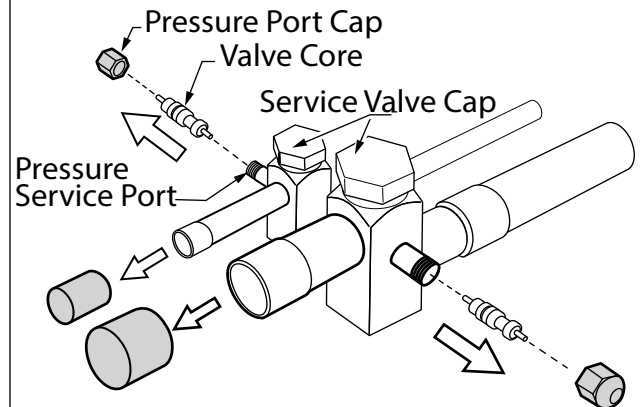

14

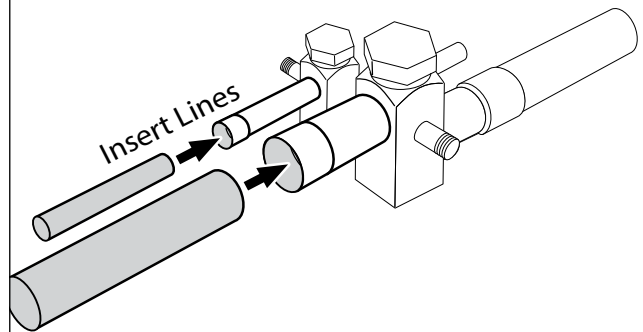

15

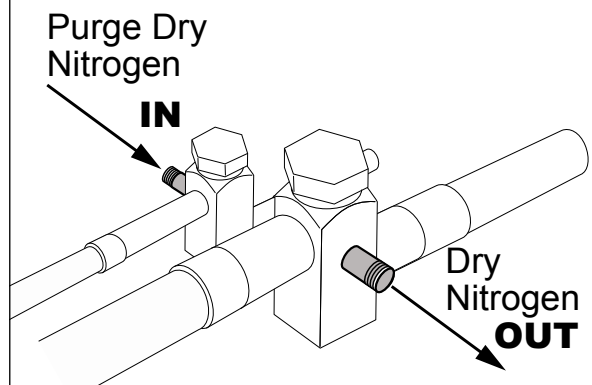

4. **Brazing steps:**

- a. Wrap a wet rag around the valve body to avoid heat damage and continue the dry nitrogen purge.
- b. Braze the refrigerant lines to the service valves (Fig. 16 and Fig. 17).

⚠ IMPORTANT ⚠
WHEN BRAZING LINE SET TO SERVICE VALVES POINT FLAME AWAY FROM SERVICE VALVE.
⚠ CAUTION ⚠
AVOID BREATHING VAPORS OR FUMES FROM BRAZING OPERATIONS. PERFORM OPERATIONS ONLY IN WELL-VENTILATED AREAS. WEAR GLOVES AND PROTECTIVE GOGGLES OR FACE SHIELD TO PROTECT AGAINST BURNS. WASH HANDS WITH SOAP AND WATER AFTER HANDLING BRAZING ALLOYS AND FLUX.

5. Continue to purge until whole brazing process is complete (Fig. 17).

⚠ IMPORTANT ⚠
ONCE THE BRAZING IS COMPLETE, REMOVE THE WET RAG BEFORE STOPPING THE DRY NITROGEN PURGE.

6. Reinstall the valve cores to service ports (Fig. 18).

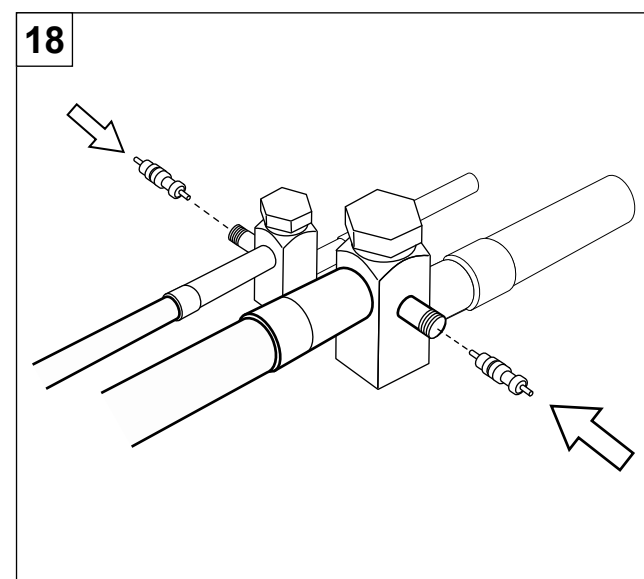
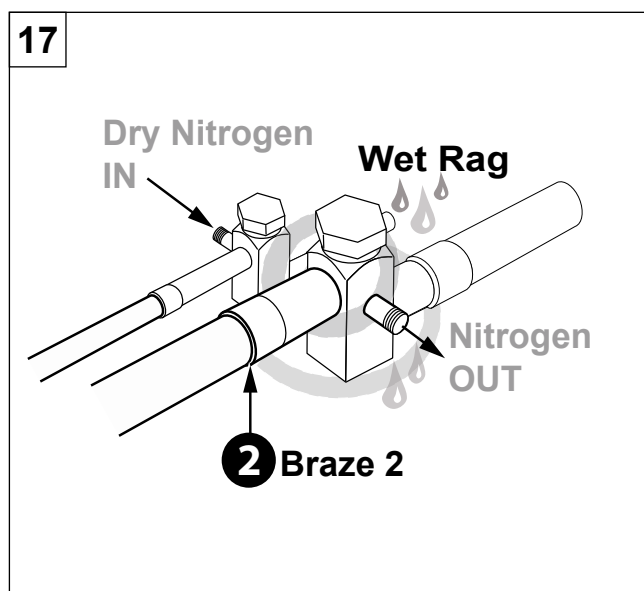
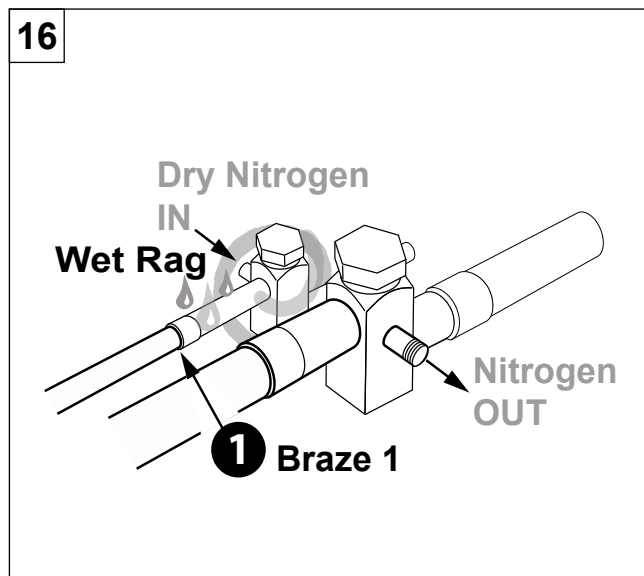

6.3.4 Refrigerant Line Leak Test

Test for leak

- Pressurize the refrigerant lines and evaporator coil to 350-400 PSIG using dry nitrogen (Fig. 19). The nitrogen pressure must be maintained for few minutes.

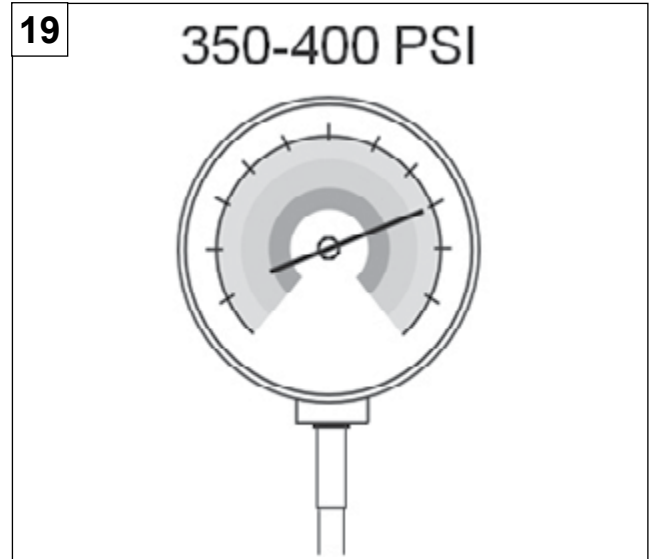

- If pressure decay is observed, it is an indication of leak(s).
- Check for leaks by using a soap solution at each brazed joint (Fig. 20).

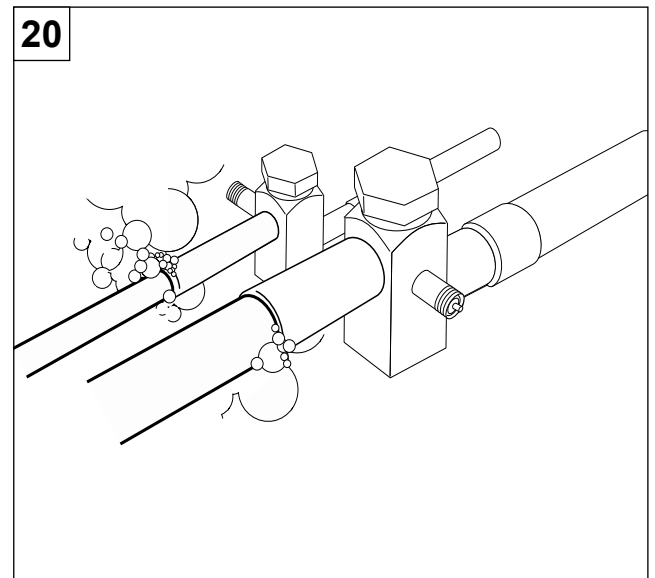

6.3.5 Refrigerant Line Insulation

- The Vapor Line must always be insulated (Fig. 21).
- DO NOT allow the liquid line and vapor line to come in direct (metal to metal) contact to each other.

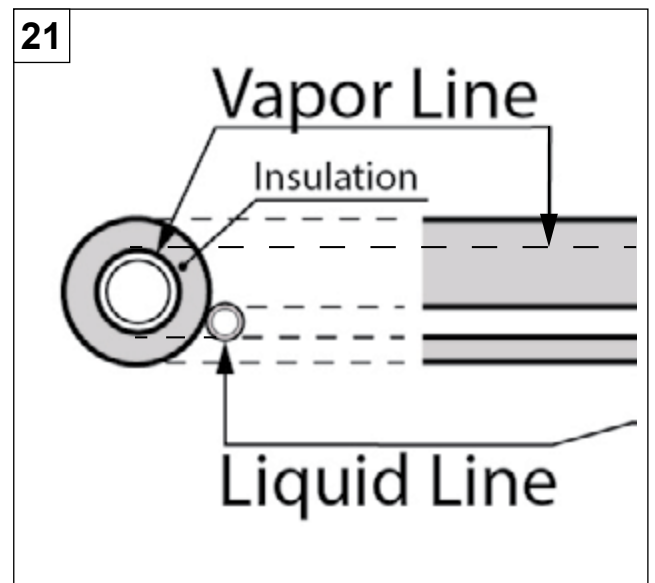

7. EVACUATION

7.1 EVACUATE THE REFRIGERANT LINES AND INDOOR COIL

⚠ WARNING ⚠

DO NOT OPEN THE SERVICE VALVES UNTIL THE REFRIGERANT LINES AND INDOOR COIL LEAK CHECK AND EVACUATION ARE COMPLETE. REFRIGERANT CAN LEAK AND MAY CAUSING MILD TO SEVERE BURNS.

- Connect the vacuum pump to evacuate the refrigerant line set and indoor coil.
- Evacuate until the micron gauge reads no higher than 350 microns or less (Fig. 22), then close **OFF** the valve to the vacuum pump.

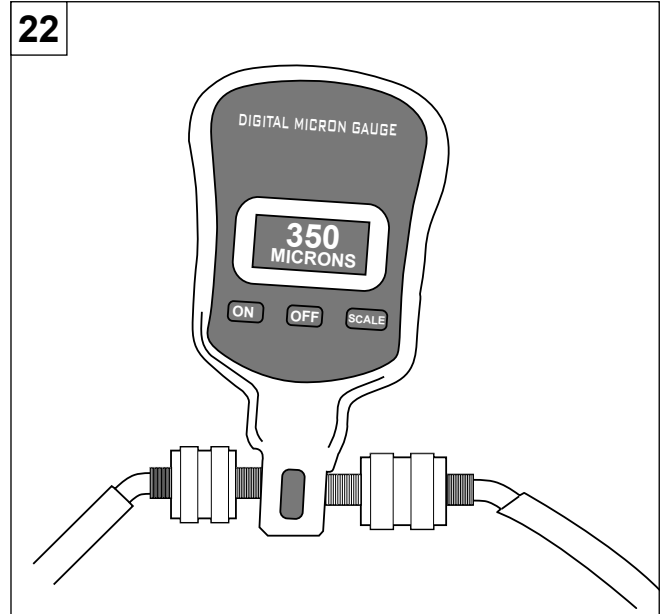

- Observe the micron gauge. Evacuation is complete if the micron gauge does not rise above 500 microns in one minute and no more the 1000 microns in 10 minutes (Fig. 23).
- When vacuum pressure rises more than 1000 microns but holds steady below 2000 microns it indicates the presence of moisture and/or non-condensable or presence of small leak. If vacuum pressure stays constantly at 2000 microns or it rises, it indicates the presence of leak.
- If the leak is found, perform the necessary repair and repeat the evacuation process.
- Once evacuation is complete, close the valves on the manifold gauge set, turn off and disconnect the vacuum pump.

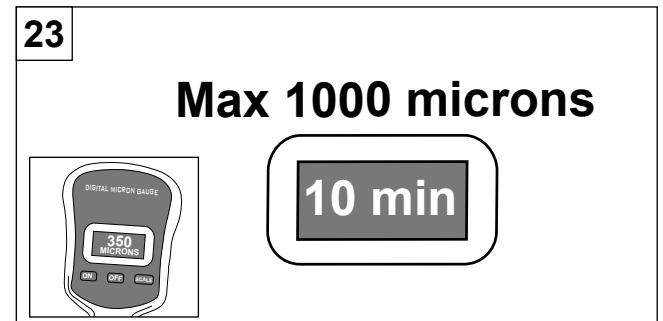

8. SERVICE VALVES

IOM

8.1 OPEN THE SERVICE VALVES

⚠ WARNING ⚠

EXTREME CAUTION MUST BE EXERCISED WHEN OPENING THE LIQUID LINE SERVICE VALVE. TURN COUNTERCLOCKWISE UNTIL THE VALVE STEM JUST TOUCHES THE ROLLED EDGE. NO TORQUE IS REQUIRED. FAILURE TO FOLLOW THIS WARNING WILL RESULT IN ABRUPT RELEASE OF SYSTEM CHARGE AND MAY RESULT IN PERSONAL INJURY AND/OR PROPERTY DAMAGE.

⚠ IMPORTANT ⚠

LEAK CHECK AND EVACUATION MUST BE COMPLETED BEFORE OPENING THE SERVICE VALVES.

⚠ CAUTION ⚠

THE VAPOR LINE SERVICE VALVE MUST BE OPENED FIRST BEFORE OPENING THE LIQUID LINE SERVICE VALVE.

1. Remove the cap from vapor service valve (Fig. 24)
2. Fully insert Allen key into the stem and rotate counterclockwise until valve stem just touches the rolled edge.
3. Replace the valve stem cap. Tighten the cap finger tight with an additional 1/6 turn.
4. Repeat STEPS 1 - 3 for Liquid Service Valve.

24

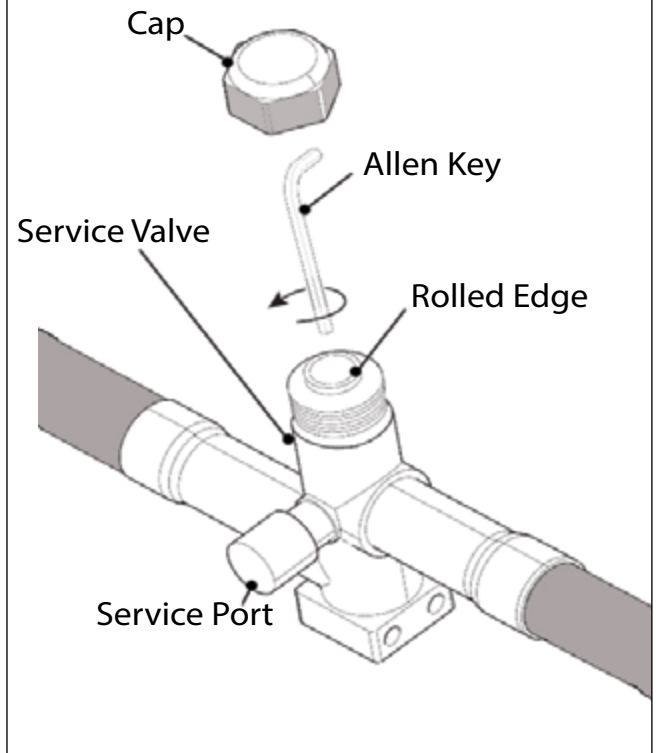

9.1.2 High Voltage Disconnect Switch

- Install a separate disconnect switch at the outdoor unit (Fig. 26).

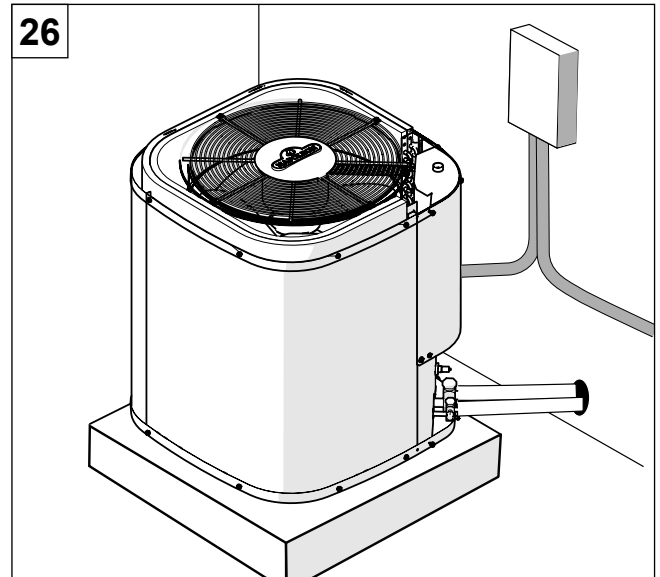

9.1.3 High Voltage Ground

Ground the outdoor unit per national, state, provincial and local code requirements (Fig. 27).

Components:

1. Contactor
2. Dual Run Capacitor
3. Ground Lug
4. Thermostat Control Wire Feed
5. High Voltage Power Cable Feed
6. Compressor and High Pressure Switch Wire Feed

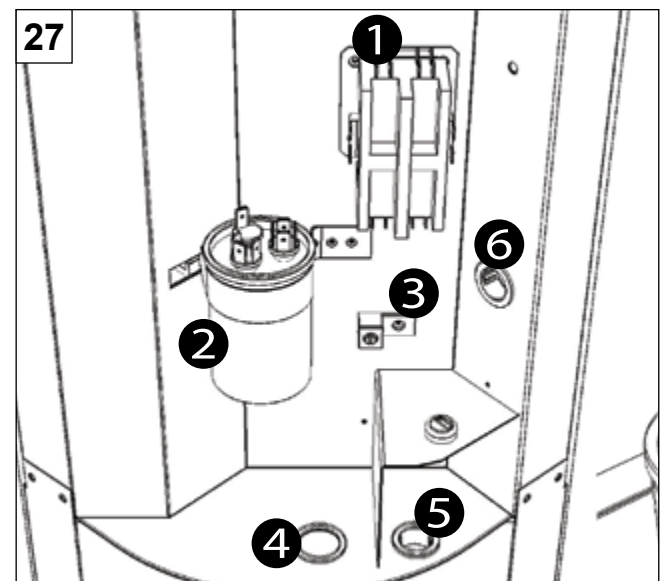

9.1.4 Thermostat

- Room thermostat (purchased separately) should be installed approximately in the center of the conditioned area on an INSIDE wall and 5 feet (1.5m) above the floor.
- Do NOT install thermostat on an outside wall or where it can be exposed to sunlight or drafts.

Good thermostat locations are:

- in a living room or dining room,
- in a position where the thermostat will be in natural air circulation (not dead air space) but where the thermostat will not be exposed to strong drafts from windows, doorways, or from a heating or cooling air

Bad Room Thermostat Locations:

- on an exterior building wall (exposed to outdoor temperature effects) where drafts from an exterior door will affect its reading
- above or in the line of airflow from a heating or cooling air supply register
- in direct sunlight
- in a kitchen, bath, or entry hallway or on a wall shared with a hot space such as a kitchen or boiler room
- in an alcove, behind an open door, behind furniture or next to concealed pipes or air ducts
- Do not place heat-emitting devices such as lamps or small appliances close to the thermostat. Their heat may affect its operation.

9.1.5 Wiring Diagram

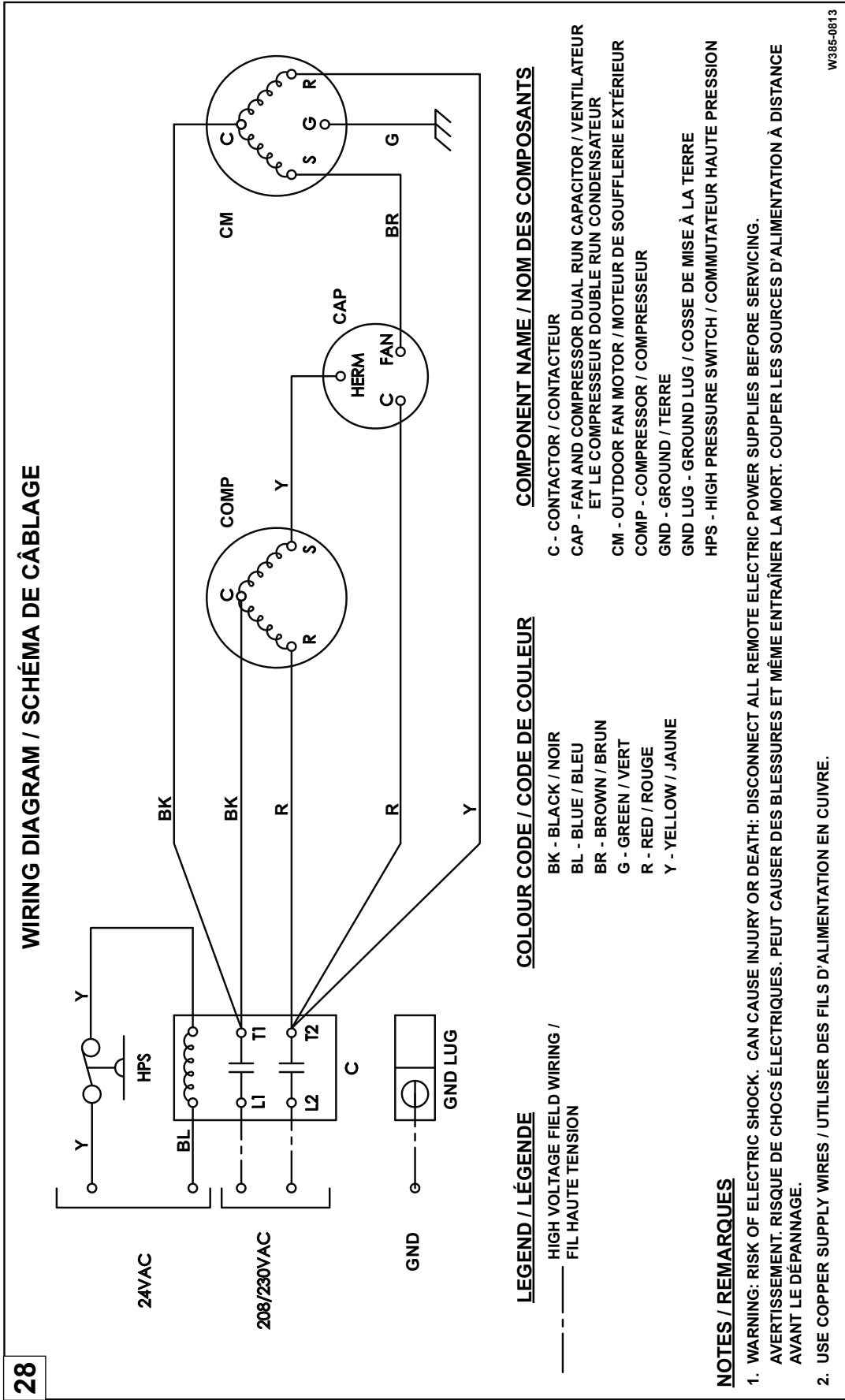

10. START UP

Perform the following steps:

1. Set System Thermostat to OFF (Fig. 29).
2. Turn disconnect switch ON (Fig. 30) to apply power to the indoor and outdoor units.

Wait:

3. If no crankcase heater accessory is used, wait five (5) minutes and go to Step 5.
4. Wait one (1) hour before starting the unit, if compressor crankcase heater accessory is used and the Outdoor Ambient is below 70°F. Refer to (Fig. 31).

29

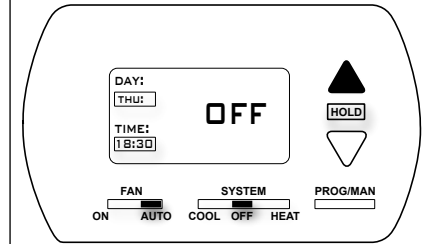

30



31

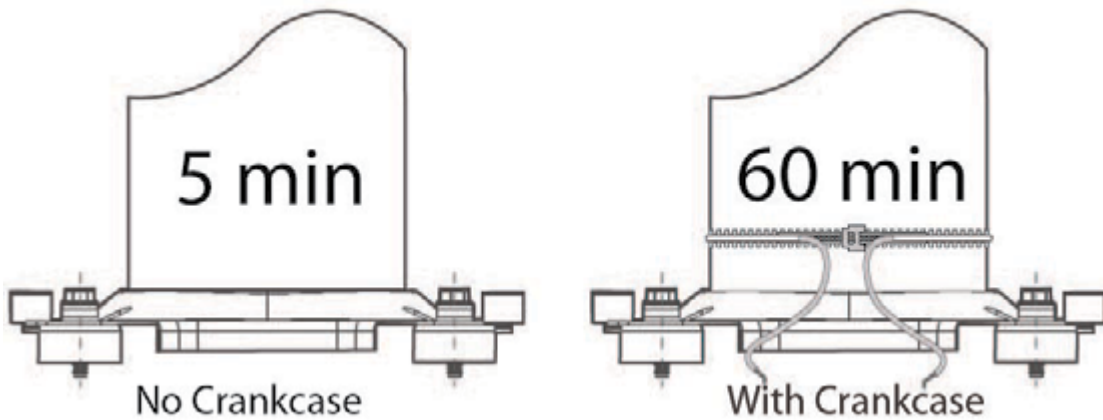

32

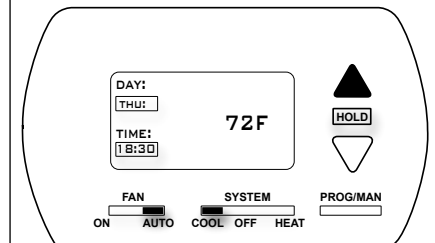

5. Set system thermostat to ON (Fig. 32).

11. SYSTEM CHARGE ADJUSTMENT

⚠ WARNING ⚠

REFRIGERANT CHARGING MUST ONLY BE ATTEMPTED BY QUALIFIED CONTRACTORS. IMPROPER SYSTEM CHARGE CAN REDUCE SYSTEM CAPACITY AND MAY CAUSE EQUIPMENT DAMAGE.

11.1 SYSTEM TOTAL CHARGE

⚠ WARNING ⚠

DO NOT LEAVE THE SYSTEM OPEN TO THE ATMOSPHERE. DO NOT ATTEMPT TO PUMP "TOTAL SYSTEM CHARGE" INTO OUTDOOR UNIT FOR MAINTENANCE, SERVICE, ETC. THIS MAY CAUSE DAMAGE TO THE COMPRESSOR AND/OR OTHER COMPONENTS. THE OUTDOOR UNIT ONLY HAS ENOUGH VOLUME FOR THE "FACTORY CHARGE", NOT FOR THE "TOTAL SYSTEM CHARGE". IT IS UNLAWFUL TO KNOWINGLY VENT, RELEASE OR DISCHARGE REFRIGERANT INTO THE OPEN AIR DURING REPAIR, SERVICE, MAINTENANCE, OR THE FINAL DISPOSAL OF THIS UNIT.

All air conditioning units come pre-charged with enough refrigerant (R410A) for an appropriately matched indoor evaporator coil. For field installed line set, a correction of 0.6Oz of R410A per foot of line set is required for 3/4" suction line diameter and 0.7 Oz of R410A per foot of line set is required for 7/8" suction line diameter. Liquid line shall be 3/8" diameter. Using evaporator coils that have not been approved as a match by the manufacturer is not recommended. Refer to AHRI directory for matched evaporator coil for your system. The system charge shall be adjusted according to section 11.2 or 11.3 depending on the application.

NOTE

To obtain an efficient system matching AHRI performance, units with either thermostatic expansion valves or piston flow raters must be installed in the vertical direction with the liquid refrigerant flowing downwards or upwards, feeding the indoor evaporator coil. The capillary tubes and expansion valve location can be adjusted to ensure that the flow through both of the slabs of the A-Coil have equal flow of refrigerant. If the temperature difference does not vary more than 10°F between the two slabs of A-coil, it indicates the equal flow of refrigerant through the each of the slabs.

11.2 ADJUSTING SYSTEM CHARGE FOR SYSTEMS USING THERMOSTATIC EXPANSION VALVES

Procedure:

1. Connect charging hose from liquid port on the refrigerant bottle to charging service port on manifold gauge.
2. Open refrigerant bottle and purge hose.
3. Connect low side of manifold gauge set to the pressure port on vapor line service valve.
4. Connect the high side of the manifold gauge set to pressure port on liquid line service valve.
5. Temporarily install a temperature measuring device on the liquid line near the liquid service valve and one at the vapor line near the vapor service valve. Ensure that the temperature measuring device makes adequate contact and insulated for accurate readings.
6. Operate the system for at least 10 minutes.
7. Check subcooling and superheat. Systems using thermostatic expansion valves should have a subcooling of 7°F to 9°F and superheat of 7°F to 9°F.
8. Record Total Charge on the nameplate and manual.

Check the nameplate for unit specific designed subcooling:

- i. If subcooling is low and superheat is normal, add charge to raise the subcooling to 7°F to 9°F.
- ii. If subcooling is low and superheat is high, add charge to raise the subcooling to 7°F to 9°F, and adjust TXV if required.
- iii. If subcooling and superheat is low, adjust the TXV to 7°F to 9°F superheat and add or remove charge if required.
- iv. If subcooling is normal and superheat is low, adjust the TXV to raise the superheat to 7°F to 9°F and remove charge if required.
- v. If subcooling is normal and superheat is high, adjust the TXV to lower the superheat to 7°F to 9°F and add charge if required.
- vi. If subcooling is high and superheat is normal, remove charge to lower the subcooling to 7°F to 9°F.
- vii. If subcooling is high and superheat is low, remove charge to lower the subcooling to 7°F to 9°F and adjust TXV.
- viii. If subcooling and superheat is high, adjust the TXV to lower the superheat to 7°F to 9°F and remove or add charge if required.

11.3 ADJUSTING SYSTEM CHARGE FOR SYSTEMS USING FIXED ORIFICE

Procedure:

- 1. Follow the steps 1-4 from paragraph 10.2.
- 2. Check superheat. The system superheat should be adjusted according to TABLE 3. A dash indicates that charging at this condition should not be attempted. Slugging may occur, leading to compressor damage.

Outdoor Ambient DB (°F)	R-410A															
	Charging Chart															
	Evaporator Suction Pressure - PSIG															
	117	120	123	126	129	132	135	138	141	144	147	150	153	156	159	162
	Evaporator Suction Temperature – Fahrenheit (°F)															
65	65	70	-	-	-	-	-	-	-	-	-	-	-	-	-	-
70	58	63	68	-	-	-	-	-	-	-	-	-	-	-	-	-
75	51	56	61	66	70	-	-	-	-	-	-	-	-	-	-	-
80	-	50	54	59	63	68	72	-	-	-	-	-	-	-	-	-
85	-	-	-	53	58	62	66	71	-	-	-	-	-	-	-	-
90	-	-	-	-	51	56	60	64	68	72	-	-	-	-	-	-
95	-	-	-	-	-	51	55	59	62	66	70	-	-	-	-	-
100	-	-	-	-	-	-	51	55	58	62	65	69	-	-	-	-
105	-	-	-	-	-	-	-	-	56	59	62	65	68	-	-	-
110	-	-	-	-	-	-	-	-	-	56	59	62	65	67	-	-
115	-	-	-	-	-	-	-	-	-	-	58	60	62	64	66	68
120	-	-	-	-	-	-	-	-	-	-	-	-	61	63	64	66
125	-	-	-	-	-	-	-	-	-	-	-	-	-	62	63	64

TABLE 3.

11.4 RECORD SYSTEM INFORMATION

Record system pressures and temperatures after charging is complete. The total system charge shall be marked on the condensing unit nameplate.

Model Number = _____
Serial Number = _____
Measured Outdoor Ambient = _____ °F
Outdoor Leaving Air Temperature = _____ °F
Indoor Air CFM = _____
Indoor Ambient = _____ °F DB _____ °F WB
Indoor Leaving Air Temperature = _____ °F DB _____ °F WB
Measured Liquid Line Temp = _____ °F
Measured Suction Line Temp = _____ °F
Liquid Gage Pressure = _____ PSIG
Suction Gage Pressure = _____ PSIG
Total System Charge = _____ OZ

12. CHECKOUT PROCEDURES

Final phases of this installation are the unit Operational and Checkout Procedures. To obtain proper performance, all units must be operated and charge adjustments made.

12.1 INSTRUCTING THE OWNER

- Assist owner with processing warranty cards and/or online registration.
- Review Owners Guide and provide a copy to the owner and guidance on proper operation and maintenance. Instruct the owner or the operator how to start, stop and adjust temperature setting.
- Instruct the owner on proper operation and maintenance of all other system components.

⚠ IMPORTANT ⚠
PERFORM A FINAL UNIT INSPECTION TO BE SURE THAT FACTORY TUBING HAS NOT SHIFTED DURING SHIPMENT. ADJUST TUBING IF NECESSARY SO TUBES DO NOT RUB AGAINST EACH OTHER WHEN THE UNIT RUNS. ALSO BE SURE WIRING CONNECTIONS ARE TIGHT AND WIRE ROUTING IS SECURE.

12.2 CHECKOUT PROCEDURE

Procedure

1. Check that unit is not damaged..... []
2. Leak check refrigerant lines..... []
3. Properly insulate suction line []
4. Ensure that lines are rated for R410A..... []
5. Properly secure and isolate all refrigerant lines..... []
6. Seal passages through masonry..... []
7. Verify that all electrical connections are tight. []
8. Verify condensing unit is not blocked by foreign objects []
9. Observe outdoor fan during on cycle for clearance and smooth operation..... []
10. Indoor coil drain line drains freely..... []
11. Supply registers and return grilles are open and unobstructed..... []
12. Return air filter is installed. []
13. Correct airflow setting is used on Indoor blower motor []
14. Operate complete system in each mode to ensure safe operation. []
15. System information recorded..... []
16. Instruct the owner on proper operation and fill out Warranty documentation []

NOTE
INSTALLER SHOULD PLACE UNIT DATA SHEET AND INSTALLATION INSTRUCTION IN CUSTOMER PACKET AND GIVE TO HOME OWNER AFTER INSTALLATION IS COMPLETE.

12.3 SYSTEM OPERATION CHECKOUT PROCEDURE

Procedure

1. With thermostat set to the OFF position, close disconnect switch or switches to complete circuits to condensing unit and furnace. Set thermostat to call for cooling.
2. After the system starts, check the voltage and amperage at the condensing unit contactor.
3. If voltage is not within 10% of rated voltage, contact the local power company for corrections - unsatisfactory performance may result.
4. If amperage greatly exceeds nameplate amperage, shut down the system and contact dealer.
5. With the system in operation, check the condensing unit for unusual noise and vibration.
6. Allow the system to operate until it is balanced or stabilized (approximately 20 minutes), before making further checks.
7. Ensure that all refrigerant in the hoses is returned to the system before removing manifold gage hoses.
8. Remove manifold gage hoses, and install caps on service valves.

13. AIR CONDITIONING TROUBLESHOOTING

TABLE 4.

	POSSIBLE CAUSE	CORRECTION
Unit will not operate	Power disconnected or loose connection	Check voltage at contactor.
	Blown fuse / breaker tripped	Replace fuses / reset breaker
	Thermostat out of calibration is set too high	Reset
	Contactors defective	Check for 24VAC at contactor coil, replace if open
	Transformer defective	Check wiring – replace transformer
	High pressure control open (if provided)	Reset – see high pressure connection
Outdoor fan on; Compressor off	Run or start capacitor defective	Replace
	Start relay defective	Replace
	Loose wire	Check for correct voltage at compressor – check and tighten all connections
	Compressor stuck, grounded or open motor winding, open internal overload	Wait at least 2 hours for overload to reset; if still open, replace the compressor
Too little cooling	Low voltage condition	Add start kit components
	Improperly sized unit	Recalculate load
	Improper indoor airflow	Check-should be approximately 400 CFM per ton
	Incorrect refrigerant charge	Charge per procedure in installation manual
	Air, non-condensables or moisture in system	Recover refrigerant
Compressor operates in short cycles	Incorrect voltage	At compressor terminals, voltage must be +/-10% of nameplate marking when unit is operating
	Defective overload protector	Replace – check for correct voltage
	Refrigerant undercharge	Add refrigerant
High head pressure; Low suction pressure	Restriction in liquid line, expansion device or filter drier	Remove or replace defective component
	Lack of sufficient indoor airflow	Clean/check filters, registers, or evaporator coil that may cause a restriction.
High head pressure; Normal suction pressure	Dirty outdoor coil	Clean coil
	Refrigerant overcharge	Correct system charge
	Outdoor fan not running	Repair or replace
	Air or non-condensables in system	Recover refrigerant, evacuate and recharge
Low head pressure; High suction pressure	Expansion device stuck in open position	Replace expansion device
	Defective compressor valves	Replace compressor

TABLE 4. CONT.

Low head pressure; High suction pressure	Expansion device stuck in open position	Replace expansion device
	Defective compressor valves	Replace compressor
Low suction pressure; Compressor cool; Ice on indoor coil	Low indoor airflow	Increase speed of blower or reduce restriction – replace air filter
	Operating below 65degF outdoors	Add low ambient kit
	Moisture in system	Recover refrigerant – evacuate and recharge – replace filter drier
High suction pressure; or fluctuating head and suction pressures	Excessive load	Recheck load calculation
	Defective compressor	Replace
	TXV hunting	Check TXV bulb clamp – check air distribution on coil – replace TXV
	Air or non-condensibles in system	Recover refrigerant, evacuate and recharge
Pulsing noise at expansion device or liquid line	Air or non-condensibles in system	Recover refrigerant, evacuate and recharge
Registers sweat	Low indoor airflow	Increase speed of blower or reduce restriction –

14. MAINTENANCE

14.1 INDOOR

1. Check air filters and replace if necessary.
2. The evaporator coil should be inspected annually for blockages.
3. Vacuum or spray the coil fins with clean water to remove dust and dirt.
4. Refer to the furnace or air handler instructions for filter and blower motor maintenance
5. The indoor coil and drain pan should be inspected and cleaned regularly to prevent odors and bacterial growth and to assure proper drainage.

14.2 OUTDOOR

- Check the condenser annually for blockages and remove foreign objects blocking the condenser.

⚠ CAUTION ⚠

DO NOT USE COIL CLEANERS TO CLEAN OUTDOOR CONDENSING COIL. CLEANERS CONTAINING HYDROGEN FLUORIDE, HYDROXIDES, CHLORIDES, AND SULFATES CAN GREATLY REDUCE THE LIFETIME OF THE ALUMINUM CONDENSING COIL.

- Clean the condenser coil by spraying it with clean water from a garden hose.
- Avoid wetting any electrical controls.
- The outdoor fan motor is permanently lubricated and does not require periodic oiling.

⚠ CAUTION ⚠

BE SURE THE UNIT DISCONNECT IS IN THE OFF POSITION AND THAT ALL ELECTRICAL POWER TO THE UNIT IS TURNED OFF BEFORE CLEANING THE SYSTEM.

If unit is not operating properly, check the following items:

- The indoor section for dirty filter and outdoor section for blockage.
- If the compressor has shutdown on thermal-overload, it may be necessary to wait for the compressor to cool down before the unit will restart.
- If the temperature setting on the thermostat is low enough to bring the air conditioner ON and system still does not start, call a service technician.

⚠ CAUTION ⚠

IT IS UNLAWFUL TO KNOWINGLY VENT, RELEASE OR DISCHARGE REFRIGERANT INTO THE OPEN AIR DURING REPAIR, SERVICE, MAINTENANCE, OR THE FINAL DISPOSAL OF THIS UNIT.

15. OWNER'S SERVICE INFORMATION

TABLE 5.

HOMEOWNER'S REFERENCE TABLE	
Model No.	
Serial No. <i>(serial number located on bottom of inside door)</i>	
Date Installed	
Contractor	
Contact	
Address	
Postal Code/Zip Code	
Telephone No.	
After Hours No.	
If different from Installation Contractor:	
Service Tech.	
Telephone No.	
After Hours No.	
NOTE:	

H28.1

16. WARRANTY

IOM

Wolf Steel Ltd. products are manufactured under the strict Standard of the world recognized ISO 9001 : 2008 Quality Assurance Certificate. **Wolf Steel Ltd.** products are designed with superior components and materials assembled by trained craftsmen who take great pride in their work. The complete appliance is thoroughly inspected by a qualified technician before packaging to ensure that you, the customer, receives the quality product that you expect from **Wolf Steel Ltd.**

NAPOLEON SPLIT AIR CONDITIONER LIMITED WARRANTY

The Napoleon Split Air Conditioners are warranted by Wolf Steel Ltd. to be free from defects in materials and workmanship under normal use and maintenance.

PRESIDENT'S LIMITED WARRANTY (Registered)

To the original registered owner and his or her spouse ("owner"), the **Napoleon Split Air Conditioner** is warranted for **10 YEARS in the home** which the unit was originally installed, except as provided below. These warranties apply only if:

- The unit is installed in an owner-occupied, primary single family residence, and
- The warranty is registered with **Wolf Steel Ltd.** online within 60 days after the original installation or possession of a new home.

OR

LIMITED WARRANTY (Not Registered)

If not registered, **all parts**, including the compressor are warranted for a period of **5 YEARS**. Should a part fail due to defect within the first year, Wolf Steel Ltd. reserves the right to replace the defective part or the entire condenser assembly at company's discretion. Diagnostics, transportation or labor charges related to warranty repair is not covered.

* *Construction of models varies. Warranty applies only to components included with your specific appliance.*

WARRANTY REGISTRATION

To register, go to **www.napoleonheatingandcooling.com** or by phone: **1-866-820-8686**. Some states and provinces do not allow limitations on how long an implied limited warranty lasts or do not allow the exclusion or limitation of incidental or consequential damages, so the limitations or exclusions may not apply to you. This limited warranty gives you specific legal rights, and you may also have other rights which vary by jurisdiction.

CONDITIONS AND LIMITATIONS

Warranty claims must be authorized by Wolf Steel Ltd. recognized representative or agent; parts/components being claimed may need to be analyzed at a Wolf Steel Ltd. facility. Records of installation date and periodic maintenance are required to process claim. All warranty service must be done by Wolf Steel Ltd. authorized service technicians using approved components.

Returned products are to be shipped prepaid to the manufacturer for investigation. If a product is found to be defective, the manufacturer will repair or replace such defect. Before shipping your appliance or defective components, your dealer must obtain an authorization number. Any merchandise shipped without authorization will be refused and returned to sender. Shipping costs are not covered under this warranty. Additional service fees may apply if you are seeking warranty service from a dealer.

Limitations:

Wolf Steel Ltd. is not responsible for:

1. Damages/Repairs/Costs incurred due to faulty installation or application.
2. Damages/Repairs/Costs caused by an installation that is not performed in compliance with all federal, provincial/state laws or regulations, and the Installation and Operation Manual.
3. Damage as a result of vandalism, freight damage, floods, fires, winds, lightning, and accidents, or any act of nature. Atmospheres contaminated by compounds of chlorine, halogenated hydrocarbons, or other damaging chemicals causing deterioration of components, or other conditions beyond the control of Wolf Steel.
4. Use of components or accessories not compatible with this appliance.
5. Products installed outside of Canada and the United States and its territories.
6. Routine maintenance, but not limited to, cleaning of the coils, filter cleaning and/or replacement and lubrication.
7. Damages/Repairs/Costs incurred because of the use of Parts not supplied or previously authorized by Wolf Steel.
8. Damages or repairs required as a result of improper use, maintenance, operation, servicing, cleaning or replacing filters.
9. Failure to operate due to interruption and/or inadequate electrical service.
10. Damages, defects or failures caused by accidents or negligent or unreasonable use or operation of the unit and its' components, including without limitation, operation beyond rated capacity and operation of electrical components at voltage other than that specified on the rating plate.
11. Wolf Steel will not in any event extend warranty coverage to any incidental, consequential or indirect damages.
12. Changes in the appearance of the unit that does not affect its performance.
13. Damages, defects or failures caused by operation of the unit in abnormal environmental conditions (i.e. salt air).
14. Damages, defects or failures caused by operating air conditioning modules during periods when outdoor ambient temperatures fall below 13°C/55°F.

ALL SPECIFICATIONS AND DESIGNS ARE SUBJECT TO CHANGE WITHOUT PRIOR NOTICE DUE TO ON-GOING PRODUCT IMPROVEMENTS. Napoleon® IS A REGISTERED TRADEMARK OF WOLF STEEL LTD. PATENTS U.S. 5,303,693,801 - CAN. 2,073,411, 2,082,915 © WOLF STEEL LTD.

FOR HOMEOWNERS FUTURE REFERENCE

Model and Serial Number _____
 (Serial number located on inside bottom door)
 Installation Date _____

Dealer Name _____
 Dealer's City/Province-State/Postal-Zip Code _____
 Telephone/Fax _____
 E-mail Address _____

For further information about this warranty, contact Wolf Steel Ltd. *Customer Solutions Department* by • phone (866) 820-8686 • by email: hvac@napoleonproducts.com • or mail to **WOLF STEEL**, 24 Napoleon Road, Barrie, Ontario L4M 0G8 Canada



www.napoleonheatingandcooling.com

NAPOLEON CELEBRATING OVER 40 YEARS OF HOME COMFORT PRODUCTS



7200, Route Transcanadienne, Montréal, Québec H4T 1A3
24 Napoleon Road, Barrie, Ontario, Canada L4M 0G8
214 Bayview Drive, Barrie, Ontario, Canada L4N 4Y8
103 Miller Drive, Crittenden, Kentucky, USA 41030

Phone: 1-866-820-8686
napoleonproducts.com
W415-1395 / C / 06.26.2017

