

This Owner's Manual is provided and hosted by [Appliance Factory Parts](#).



Napoleon NT14H024A Owner's Manual

**[Shop genuine replacement parts for Napoleon
NT14H024A](#)**

COMPONENTS

1. SIDE PANELS

- Vertical extruded slots on the side panels protect the interior of Napoleon Heat Pump while allowing the right amount of air flow
- Powder coated cabinet panels withstanding 1000 hours of salt spray testing

2. VENTURI

- Integral to the housing, a deep venturi is used in conjunction with the swept fan blade to provide more efficient air flow

3. SWEEP FAN BLADES

- Contoured blades provide quieter operation
- Produces efficient air flow
- Fans are made up of 4 or 2 fan blades to accommodate the unit cooling capacity

4. SCROLL COMPRESSOR

- Industry leading compressor brand
- Low vibration and quiet operation
- Contains built-in safety features

[Find Your Napoleon HVAC Parts - Select From 105 Models](#)

----- Manual continues below -----

INSPECT THE SHIPPING CONTAINER IMMEDIATELY UPON RECEIVING YOUR UNIT. ANY DAMAGE SHOULD BE NOTED ON FREIGHT BILL BEFORE SIGNING AND CLAIMS SHOULD BE FILLED WITH CARRIER AS SOON AS POSSIBLE. MAKE SURE THAT RATING PLATE MATCHES THE MODEL NUMBER YOU PURCHASED.



INSTALLER: PLEASE FAMILIARIZE YOURSELF WITH THIS MANUAL BEFORE PROCEEDING WITH THE INSTALLATION. LEAVE THIS MANUAL WITH THE APPLIANCE FOR FUTURE REFERENCE.
CONSUMER: RETAIN THIS MANUAL FOR FUTURE REFERENCE.

IOM

INSTALLATION AND OPERATING INSTRUCTIONS

Conforms to UL Standard 1995. Certified to CAN/CSA Standard C22.2 No.236.



SPLIT SYSTEM HEAT PUMPS

⚠ WARNING ⚠

ELECTRICAL SHOCK, FIRE OR EXPLOSION HAZARD

FAILURE TO FOLLOW SAFETY WARNINGS AND INSTRUCTIONS EXACTLY COULD RESULT IN SERIOUS INJURY, DEATH OR PROPERTY DAMAGE.

THIS INFORMATION IS INTENDED FOR USE BY QUALIFIED HVAC TECHNICIANS POSSESSING ADEQUATE BACKGROUNDS OF ELECTRICAL AND MECHANICAL EXPERIENCE. ANY ATTEMPT TO REPAIR A HEAT PUMP PRODUCT MAY RESULT IN PERSONAL INJURY AND/OR PROPERTY DAMAGE. THE MANUFACTURER OR SELLER CANNOT BE RESPONSIBLE FOR THE INTERPRETATION OF THIS INFORMATION, NOR CAN IT ASSUME ANY LIABILITY IN CONNECTION WITH ITS USE.

⚠ CAUTION ⚠

UNIT CONTAINS R-410A REFRIGERANT AND POE COMPRESSOR OIL! USE ONLY R-410A REFRIGERANT AND APPROVED POE COMPRESSOR OIL. REFRIGERANT LINES MUST BE BRAZED AND RATED FOR R-410 PRESSURES!

PROPER SERVICE EQUIPMENT IS REQUIRED. USE ONLY R-410A APPROVED SERVICE EQUIPMENT. FAILURE TO USE PROPER SERVICE TOOLS MAY RESULT IN EQUIPMENT DAMAGE OR PERSONAL INJURY.

INSTALLATION SHALL BE MADE IN ACCORDANCE WITH THE REQUIREMENTS OF THE LOCAL UTILITY AND OTHER AUTHORITIES HAVING JURISDICTION, THE NATIONAL ELECTRICAL CODE IN THE UNITED STATES AND THE CANADIAN ELECTRICAL CODE CSA C22.1 PART 1 (LATEST EDITION) IN CANADA. ANY ALTERATION OF INTERNAL WIRING WILL VOID CERTIFICATION AND WARRANTIES.

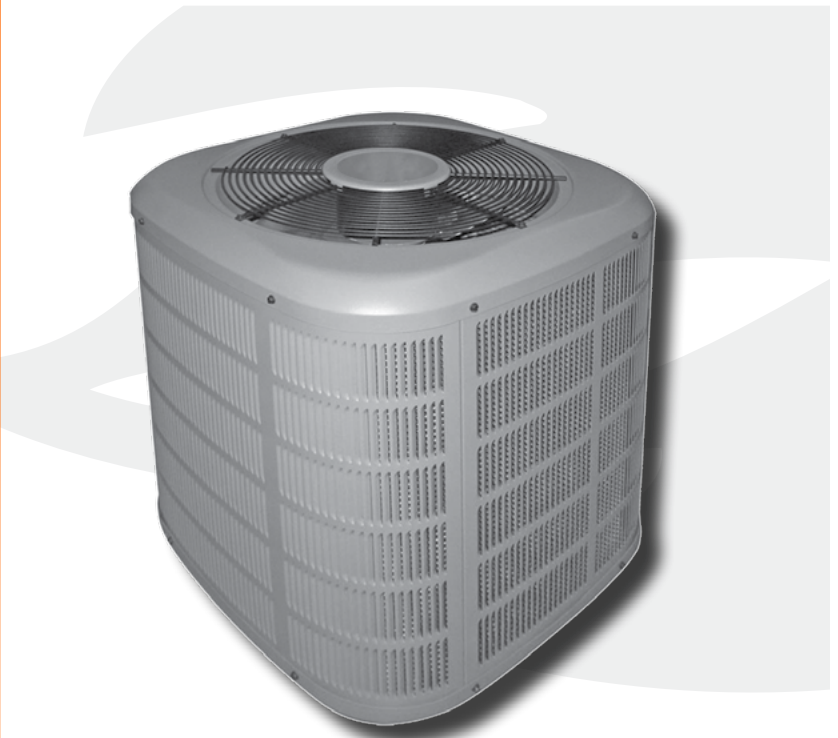

Powered By:

Copeland
brand products



Congratulations on the purchase of your Napoleon Heat Pump. Napoleon's line of Split System Heat Pumps offer industry leading quality and are equipped with multiple advanced features:

FEATURES:

- Capacities from 1.5 to 4.0 tons
- Utilizes environmentally friendly R-410A refrigerant
- High Efficiency Copeland Scroll Compressors
- High Efficiency Finned Tube Coils
- Swept Fan Blades

MANUFACTURER RESERVES THE RIGHT TO DISCONTINUE, OR CHANGE AT ANY TIME, SPECIFICATIONS OR DESIGNS WITHOUT NOTICE AND WITHOUT INCURRING OBLIGATIONS.

Wolf Steel Ltd., 24 Napoleon Rd., Barrie, ON, L4M 0G8 Canada /
103 Miller Drive, Crittenden, Kentucky, USA, 41030
Phone (705)721-1212 • Fax (705)722-6031 • www.napoleonheatingandcooling.com
• hvac@napoleonproducts.com

TABLE OF CONTENTS

1. MODEL NOMENCLATURE	2
2. OVERVIEW	3
3. SAFETY	3
3.1 SAFETY SYMBOLS	3
3.2 SAFETY RULES	4
3.3 CODES	5
4. LIMITATIONS	5
5. LOCATION AND CLEARANCE	6
5.1 CLEARANCE	6
5.2 LOCATION RESTRICTIONS	6
6. INSTALLATION	7
6.1 SUPPORT	7
6.2 UNIT PLACEMENT	7
6.3 REFRIGERANT LINE SET INSTALLATION	8
7. EVACUATION	13
7.1 EVACUATE THE REFRIGERANT LINES AND INDOOR COIL	13
8. SERVICE VALVES	14
8.1 OPEN THE SERVICE VALVES	14
9. ELECTRICAL	15
9.1 LOW VOLTAGE CONNECTIONS	15
9.2 HIGH VOLTAGE CONNECTIONS	15
10. START UP	18
11. SYSTEM CHARGE ADJUSTMENT	19
11.1 SYSTEM TOTAL CHARGE	19
11.2 ADJUSTING SYSTEM CHARGE FOR SYSTEMS USING THERMOSTATIC EXPANSION VALVES	20
11.3 RECORD SYSTEM INFORMATION	20
12. CHECKOUT PROCEDURES	21
12.1 INSTRUCTING THE OWNER	21
12.2 CHECKOUT PROCEDURE	21
12.3 SYSTEM OPERATION CHECKOUT PROCEDURE	21
13. HEAT PUMP TROUBLESHOOTING	22
13.1 DIAGNOSTIC CHART FOR COOLING MODE	22
13.2 DIAGNOSTIC CHART FOR HEATING MODE	23
14. MAINTENANCE	24
14.1 INDOOR	24
14.2 OUTDOOR	24
15. OWNER'S SERVICE INFORMATION	25
16. WARRANTY	27

SHIPPING INSPECTION: The unit is shipped in one package, completely assembled and wired. Inspect the shipping container immediately upon receiving your unit. If it appears that damage has occurred, it should be noted on the freight bill before signing. Damage claims should be filed with the carrier as quickly as possible. Check the rating plate (at the front of the access panel) to confirm capacities. The unit **MUST** be operated only with the type of refrigerant, oil and electrical supply noted on the rating plate.

1. MODEL NOMENCLATURE

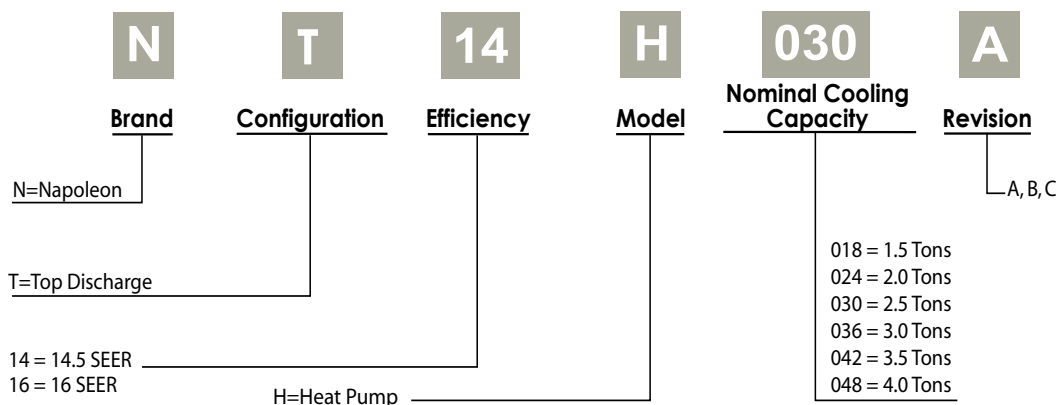

2. OVERVIEW

These instructions cover installation of Napoleon Split System Heat Pumps. Napoleon's line of Split Heat Pumps offer industry leading quality and reliability. All outdoor units have been factory run-tested and ready for easy installation.

Napoleon's line of Split Heat Pumps are designed to perform for many years. These instructions are intended as an aid to the licensed service technician to properly install the unit. Improper installation may damage equipment, void the warranty, and can create a hazard, resulting in property damage, injury or death.

Our Heat Pump systems and components are designed to be installed by qualified HVAC technicians ONLY. The installation of Heat Pump systems includes electrical and refrigerant connections and is regulated by a multiple sets of laws, codes and guidelines, at the federal, state and local levels. It is the installer's responsibility to install the product in accordance with all applicable codes and regulations. It is the homeowner's responsibility to properly maintain the equipment. NO WARRANTY is offered for the products that were installed by unlicensed/unauthorized persons. Failure to comply with this policy could lead to violations of applicable laws that are punishable.

Documentation and specifications are continuously updated and subject to change. Please download the latest version of specifications and manuals at <http://www.napoleonheatingandcooling.com>.

3. SAFETY

3.1 SAFETY SYMBOLS

Understand and pay particular attention to the words DANGER, WARNING, and CAUTION and the following defined symbols are used throughout this manual to notify the reader of potential hazards of varying risk levels.
⚠ DANGER ⚠
INDICATES AN IMMINENTLY HAZARDOUS SITUATION WHICH, IF NOT AVOIDED, WILL RESULT IN DEATH OR SERIOUS INJURY.
⚠ WARNING ⚠
INDICATES A POTENTIALLY HAZARDOUS SITUATION WHICH, IF NOT AVOIDED, COULD RESULT IN DEATH OR SERIOUS INJURY.
⚠ CAUTION ⚠
INDICATES A POTENTIAL HAZARDOUS SITUATION WHICH, IF NOT AVOIDED, MAY RESULT IN MINOR OR MODERATE INJURY. IT MAY ALSO BE USED TO ALERT AGAINST UNSAFE PRACTICES.
⚠ IMPORTANT ⚠
SUGGESTS IMPORTANT PROCEDURE STEPS TO INSURE PROPER INSTALLATION, RELIABILITY, OR OPERATION.
NOTE
HIGHLIGHTS SUGGESTIONS WHICH WILL RESULT IN ENHANCED INSTALLATION, RELIABILITY, OR OPERATION.

3.2 SAFETY RULES

IMPORTANT:

READ THE FOLLOWING INSTRUCTIONS COMPLETELY BEFORE INSTALLING!

H6.0

⚠ WARNING ⚠

THIS INFORMATION IS INTENDED FOR USE BY QUALIFIED HVAC TECHNICIANS POSSESSING ADEQUATE BACKGROUNDS OF ELECTRICAL AND MECHANICAL EXPERIENCE. ANY ATTEMPT TO REPAIR HEAT PUMP PRODUCT MAY RESULT IN PERSONAL INJURY AND/OR PROPERTY DAMAGE. THE MANUFACTURER OR SELLER CANNOT BE RESPONSIBLE FOR THE INTERPRETATION OF THIS INFORMATION, NOR CAN IT ASSUME ANY LIABILITY IN CONNECTION WITH ITS USE.

⚠ CAUTION ⚠

UNIT CONTAINS R-410A REFRIGERANT AND POE COMPRESSOR OIL.
USE ONLY R-410A REFRIGERANT AND APPROVED POE COMPRESSOR OIL.
REFRIGERANT LINES MUST BE BRAZED AND RATED FOR R410 PRESSURES!
PROPER SERVICE EQUIPMENT IS REQUIRED. USE ONLY R-410A APPROVED SERVICE EQUIPMENT. FAILURE TO USE PROPER SERVICE TOOLS MAY RESULT IN EQUIPMENT DAMAGE OR PERSONAL INJURY.

ALL R-410A SYSTEMS USE POE OIL. POE OIL EASILY ABSORBS MOISTURE FROM THE AIR. A SYSTEM WHICH HAS BEEN EXPOSED TO THE ATMOSPHERE FOR MORE THAN 4 HOURS REQUIRES THAT THE COMPRESSOR OIL BE REPLACED. NEVER BREAK A VACUUM WITH AIR AND ALWAYS CHANGE THE FILTER DRIER WHEN OPENING THE SYSTEM FOR COMPONENT REPLACEMENT.

⚠ WARNING ⚠

HOT SURFACE! DO NOT TOUCH TOP OF COMPRESSOR.
COMPRESSOR AND DISCHARGE PIPES MAY BE EXTREMELY HOT.
IT MAY CAUSE MINOR TO SEVERE BURNING.

⚠ CAUTION ⚠

DURING INSTALLATION, TESTING, SERVICING, AND TROUBLESHOOTING OF THIS PRODUCT, IT MAY BE NECESSARY TO WORK WITH ELECTRICAL COMPONENTS. THERE IS A RISK OF ELECTRIC SHOCK. IT CAN CAUSE INJURY OR DEATH:
DISCONNECT ALL REMOTE ELECTRIC POWER SUPPLIES BEFORE SERVICING!

H3.3.7_HP

⚠ WARNING ⚠

THESE INSTRUCTIONS ARE INTENDED AS AN AID TO QUALIFIED SERVICE PERSONNEL FOR PROPER INSTALLATION, ADJUSTMENT AND OPERATION OF THIS UNIT. READ THESE INSTRUCTIONS THOROUGHLY BEFORE ATTEMPTING INSTALLATION OR OPERATION. FAILURE TO FOLLOW THESE INSTRUCTIONS MAY RESULT IN IMPROPER INSTALLATION, ADJUSTMENT, SERVICE OR MAINTENANCE, POSSIBLY RESULTING IN FIRE, ELECTRICAL SHOCK, EXPLOSION, PROPERTY DAMAGE, PERSONAL INJURY OR DEATH.

NOTE

USE ONLY AUTHORIZED HVAC PARTS. USE OF OTHER PARTS MAY VOID WARRANTY OR ADVERSELY IMPACT PERFORMANCES.

1. Only trained service technicians familiar with standard service instructions and training materials should attempt installation, service, and repair of these units. Failure to follow these instructions may result in improper installation, adjustment, alteration, service, maintenance, or use that can cause explosion, fire, electrical shock, or other conditions which may cause death, personal injury, or property damage. For information or assistance, consult a qualified installer, service agency, your distributor or branch.
2. Unit contains R-410A refrigerant and POE compressor oil! Use only R-410A refrigerant and approved POE compressor oil. Refrigerant lines must be brazed and rated for R410A pressures!
3. Follow all safety codes.
4. Wear safety glasses, protective clothing, and work gloves.
5. Have fire extinguisher available.
6. Read instructions thoroughly and follow all warnings or cautions included in literature and attached to the unit. Consult federal, provincial, state, and local codes for special requirements.

3.3 CODES

This unit must be installed in accordance with all local codes, by-laws and regulations by those authorities having jurisdiction.

Electrical connections must be made in accordance with:

- a. Canada: current edition of CAN/CSA C22.1 and C22.2, Canadian Electrical Code (Part 1 and 2).
- b. United States: current edition of ANSI/NFPA 70, National Electrical Code.

Codes and additional information may be obtained from:

Canadian Standards Association
5060 Spectrum Way
Mississauga, Ontario, L4W 5N6
Phone: (416) 747-4000
website: www.csa.ca

National Fire Protection Association
1 Batterymarch Park
Quincy, MA, 02169-7471
Phone: (617) 770-3000
website: www.nfpa.org

American Gas Association
400 North Capitol Street, NW,
Suite 450
Washington DC, 20001
Phone: (202) 824-7000
website: www.aga.org

4. LIMITATIONS

The unit should be installed in accordance with all National, Provincial/State and Local Safety Codes and the limitations listed below:

1. Limitations for the indoor unit, coil, and appropriate accessories must also be observed.
2. The outdoor unit must not be installed with any duct work in the air stream. The outdoor fan is the propeller type and is not designed to operate against any additional external static pressure.
3. The maximum and minimum conditions for operation must be observed to assure a system that will give maximum performance with minimum service.

TABLE 1: MIN/MAX OPERATING LIMIT CONDITIONS							
Air temperature at OUTDOOR COIL, ° F (°C)				Air temperature at INDOOR COIL, ° F (°C)			
MIN.		MAX.		MIN.		MAX.	
DB Cool	DB Heat	DB Cool	DB Heat	WB Cool	DB Heat	WB Cool	DB Heat
50 (10)	17 (-8)	115 (46)	75 (24)	57 (14)	50 (10)	72 (22)	80 (27)

5. LOCATION AND CLEARANCE

5.1 CLEARANCE

The minimum clearances required for installation and accessibility are shown below. These clearances should be followed unless otherwise approved by the manufacturer.

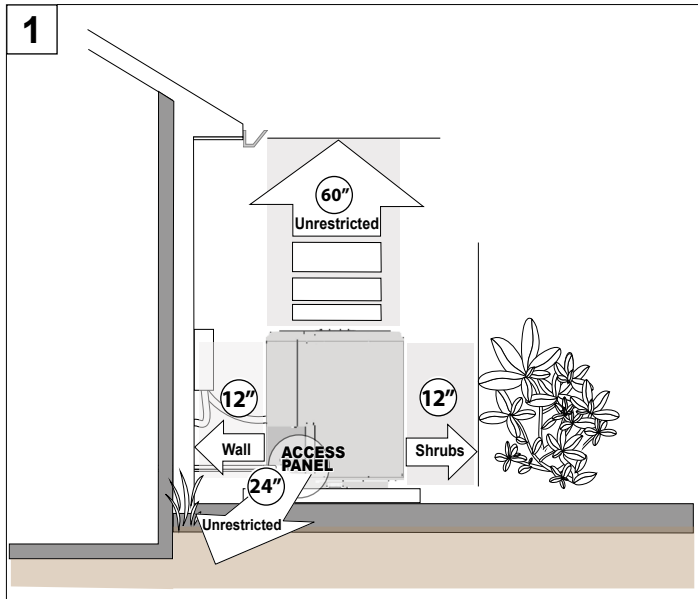

- Ensure the top discharge area is unrestricted for at least 60" above the unit (Figure 1.).
- Clearance must be provided in front of the access panel for servicing and adequate airflow around the cabinet as shown on Fig.1, 2 & 3.
- The distance in between two or more units will be 24" minimum.

5.2 LOCATION RESTRICTIONS

- Do not locate unit close to bedrooms or areas where operational sounds may be objectionable (Fig. 4).
- Outdoor unit location must be far enough away from any structure to prevent excess runoff water from pouring directly on to the unit (Fig. 5). Check with National and Local Codes.
- When installing units on a roof, the structure must be capable of supporting the total weight of the unit, including a padded frame unit, rails, etc.

NOTE

Heat pumps will defrost periodically resulting in water drainage. The unit should not be located where water drainage may freeze and create a hazardous condition (such as sidewalks and steps).

5.2.1 Cold Climate Considerations

In areas where snow accumulation and prolonged below-freezing temperatures occur, the following precautions are recommended:

- Units should be elevated 3"-12" above the pad. This elevation will allow drainage of snow and ice melted during defrost cycle prior to its refreezing.
- Ensure that drain holes in unit base pan are not obstructed, preventing draining of defrost water.
- If possible, avoid locations that are likely to accumulate snow drifts. If not possible, a snow drift barrier should be installed around the unit to prevent a build-up of snow on the sides of the unit.

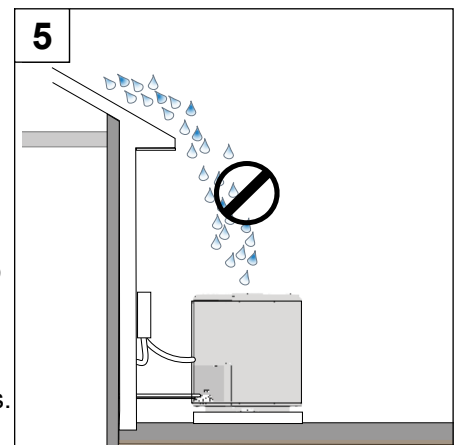
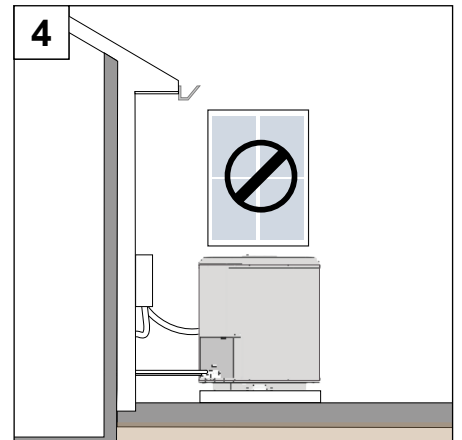
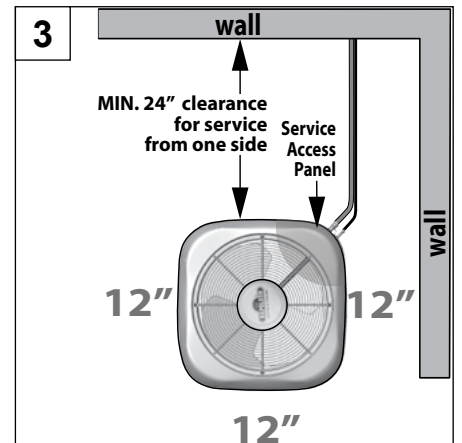
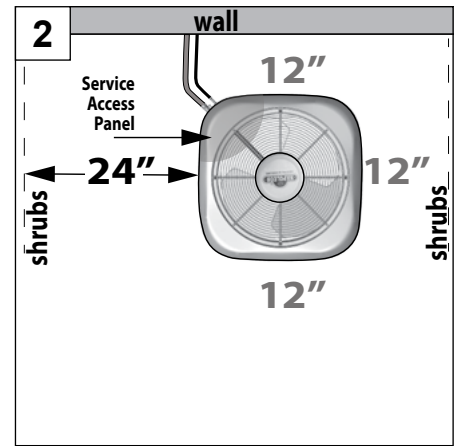

6. INSTALLATION

6.1 SUPPORT

Support pad:

1. The pad must be:
 - a. separate from any structure.
 - b. at least 2" larger than the unit on all sides and high enough (6" recommended) to allow for drainage (Fig 6).

- c. The pad must be level (Fig 7). The pad location must comply with National, State, and Local codes.

If on a slope: Maintain slope tolerance of two (2) degrees (or two inches per five feet [50 mm per 1.5 m]) away from building structure.
- d. For areas that have below freezing temperatures Heat Pump must be installed on an elevated stand or risers to allow unobstructed drainage and air flow. For precautions and recommendations see 5.2.1 "Cold Climate Considerations".

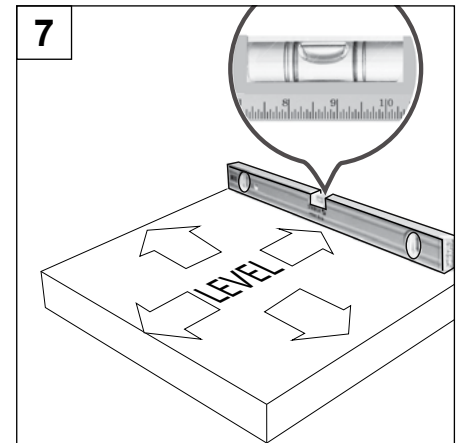
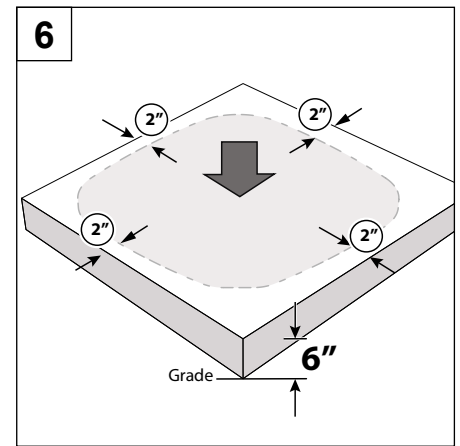

6.2 UNIT PLACEMENT

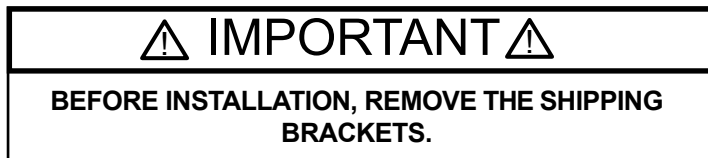

2. Remove screws holding four brackets to the pallet and lift off the clips (Fig 8).

3. Center, position and place the unit onto pad or risers (Fig 9). Heat Pump Risers are used to elevate the system from the potential threat of rain or snow and to provide extra ventilation underneath the unit.

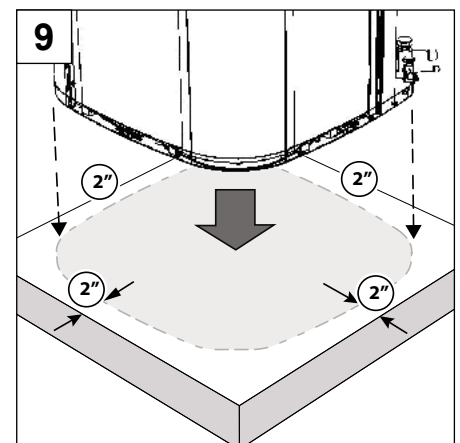
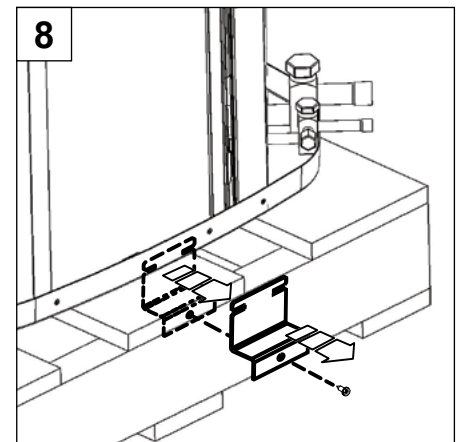

6.3 REFRIGERANT LINE SET INSTALLATION

6.3.1 Refrigerant Piping Limitations

10

- Maximum line length = 100 feet.

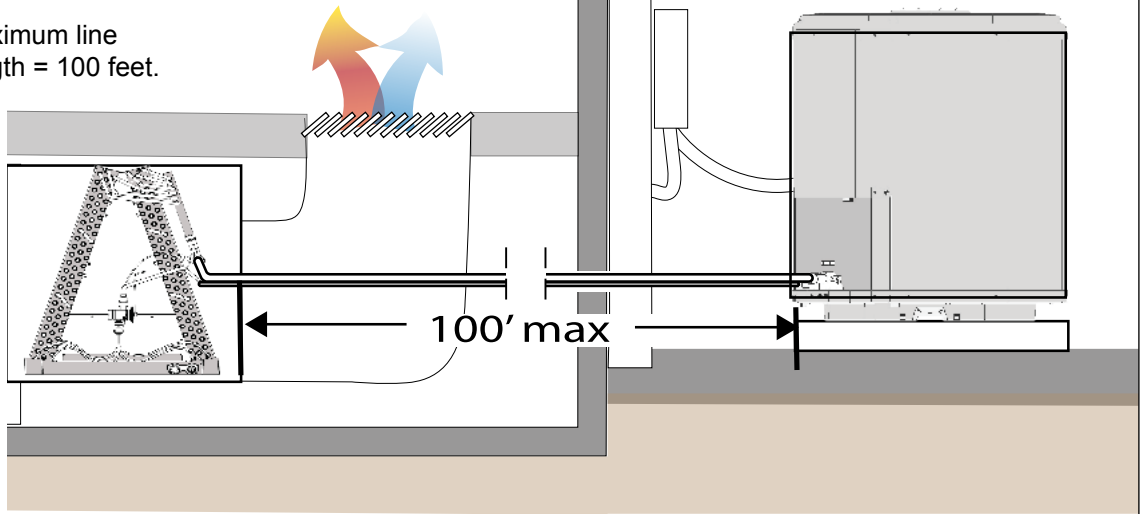

11

- Maximum vertical height = 60 feet.

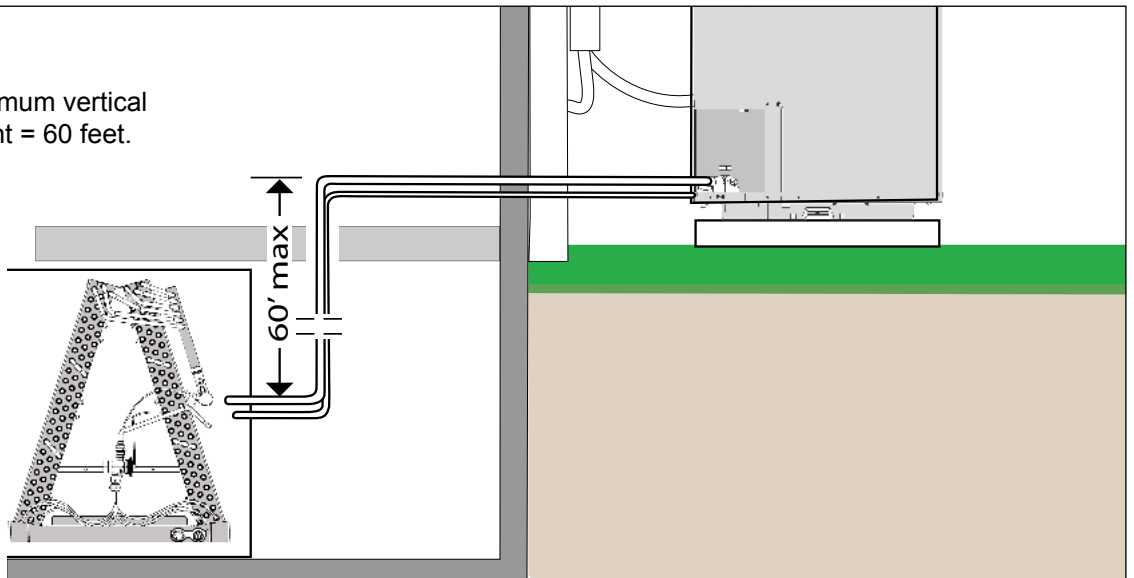

12

- Maximum vertical height = 60 feet.
- Compressor crankcase heater is required for line lengths over 60 feet.
- Use only the line diameters indicated in TABLE 2.

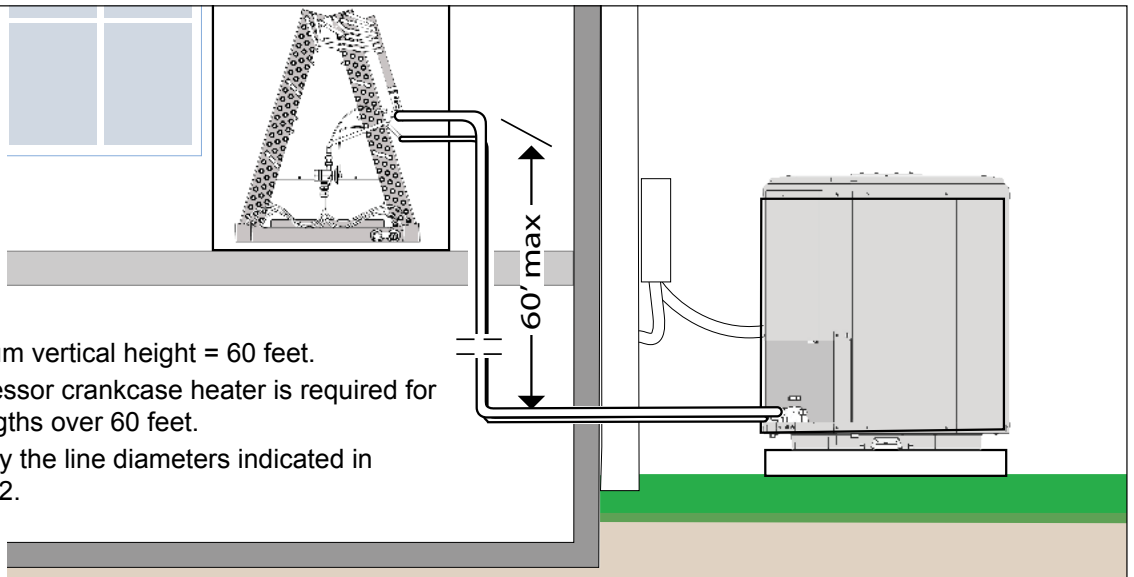

6.3.2 Refrigerant Line and Service Valve Connection Sizes

PIPING CONNECTIONS

The outdoor unit must be connected to the indoor unit using field supplied refrigerant grade (ACR) copper tubing that is internally clean and dry. Units should be installed only with the tubing sizes for approved system combinations as specified in tabular data sheet. The charge given is applicable for total tubing lengths up to 15 feet (4.6m).

NOTE

- USING A LARGER THAN SPECIFIED LINE SIZE COULD RESULT IN OIL RETURN PROBLEMS.
- USING TOO SMALL A LINE WILL RESULT IN LOSS OF CAPACITY AND OTHER PROBLEMS CAUSED BY INSUFFICIENT REFRIGERANT FLOW.
- SLOPE HORIZONTAL VAPOR LINES AT LEAST 1" EVERY 20 FEET TOWARD THE OUTDOOR UNIT TO FACILITATE PROPER OIL RETURN.

TABLE 3.

MODEL	Line Sizes		Service Valve Connection Sizes	
	Vapor Line	Liquid Line	Vapor Line Connection	Liquid Line Connection
1.5 T ons	3/4	3/8	3/4	3/8
2.0 Tons	3/4	3/8	3/4	3/8
2.5 Tons	3/4	3/8	3/4	3/8
3.0 Tons	3/4	3/8	3/4	3/8
3.5 Tons	7/8	3/8	7/8	3/8
4.0 Ton s	7/8	3/8	7/8	3/8

6.3.3 Line Brazing

⚠ WARNING ⚠

REFRIGERANT LINES MUST BE BRAZED AND RATED FOR R410A PRESSURES!

⚠ WARNING ⚠

DO NOT REMOVE SERVICE VALVE CAPS UNTIL SECTION 7.

⚠ CAUTION ⚠

DRY NITROGEN SHOULD ALWAYS BE SUPPLIED THROUGH THE TUBING WHILE IT IS BEING BRAZED, BECAUSE THE TEMPERATURE REQUIRED IS HIGH ENOUGH TO CAUSE OXIDATION OF THE COPPER UNLESS AN INERT ATMOSPHERE IS PROVIDED. THE FLOW OF DRY NITROGEN SHOULD CONTINUE UNTIL THE JOINT HAS COOLED. ALWAYS USE A PRESSURE REGULATOR AND SAFETY VALVE TO INSURE THAT ONLY LOW PRESSURE DRY NITROGEN IS INTRODUCED INTO THE TUBING. ONLY A SMALL FLOW IS NECESSARY TO DISPLACE AIR AND PREVENT OXIDATION.

⚠ WARNING ⚠

NEVER ATTEMPT TO REPAIR ANY BRAZED CONNECTIONS WHILE THE SYSTEM IS UNDER PRESSURE. PERSONAL INJURY COULD RESULT.

1. Remove plastic caps from the service valve connections. Remove the pressure port caps and valve cores from pressure service ports (Fig. 13).
2. Cut ends of the refrigerant lines square (free from nicks or dents) and debur the ends. The pipe must remain round. Install lines into service valve connections (Fig. 14).
3. Purge the refrigerant line and indoor coil with dry nitrogen (Fig. 15). Continue to purge until whole brazing process is complete.

13

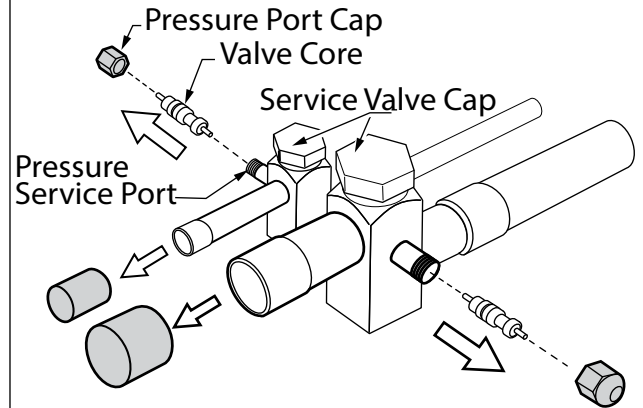

14

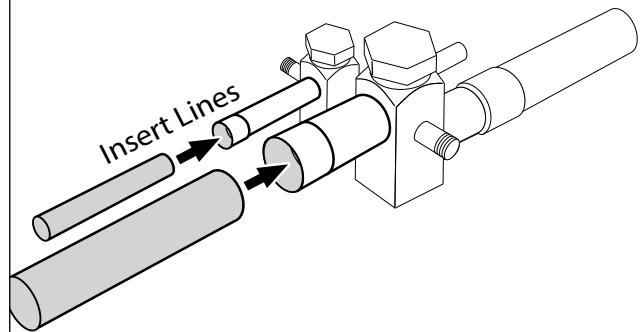

15

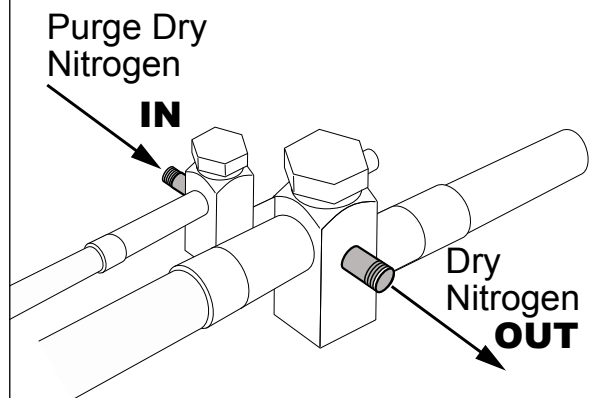

4. **Brazing steps:**

- a. Wrap a wet rag around the valve body to avoid heat damage and continue the dry nitrogen purge.
- b. Braze the refrigerant lines to the service valves (Fig. 16 and Fig. 17).

⚠ IMPORTANT ⚠
WHEN BRAZING LINE SET TO SERVICE VALVES POINT FLAME AWAY FROM SERVICE VALVE.
⚠ CAUTION ⚠
<p>AVOID BREATHING VAPORS OR FUMES FROM BRAZING OPERATIONS.</p> <p>PERFORM OPERATIONS ONLY IN WELL-VENTILATED AREAS.</p> <p>WEAR GLOVES AND PROTECTIVE GOGGLES OR FACE SHIELD TO PROTECT AGAINST BURNS.</p> <p>WASH HANDS WITH SOAP AND WATER AFTER HANDLING BRAZING ALLOYS AND FLUX.</p>

5. Continue to purge until whole brazing process is complete (Fig. 17).

⚠ IMPORTANT ⚠
ONCE THE BRAZING IS COMPLETE, REMOVE THE WET RAG BEFORE STOPPING THE DRY NITROGEN PURGE.

6. Reinstall the valve cores to service ports (Fig. 18).

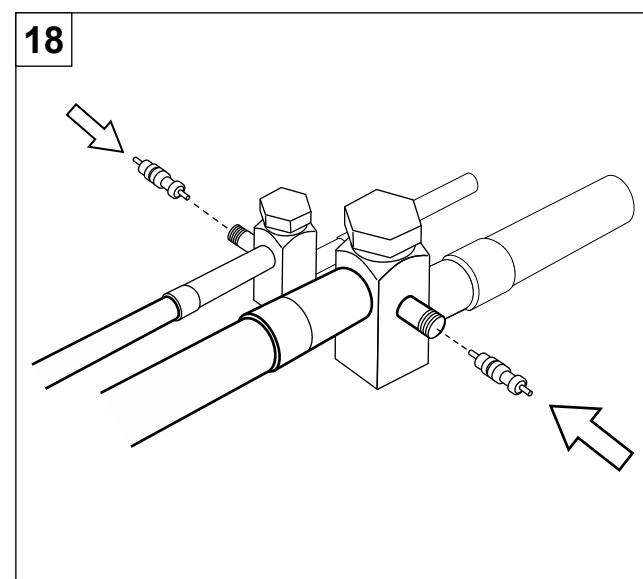
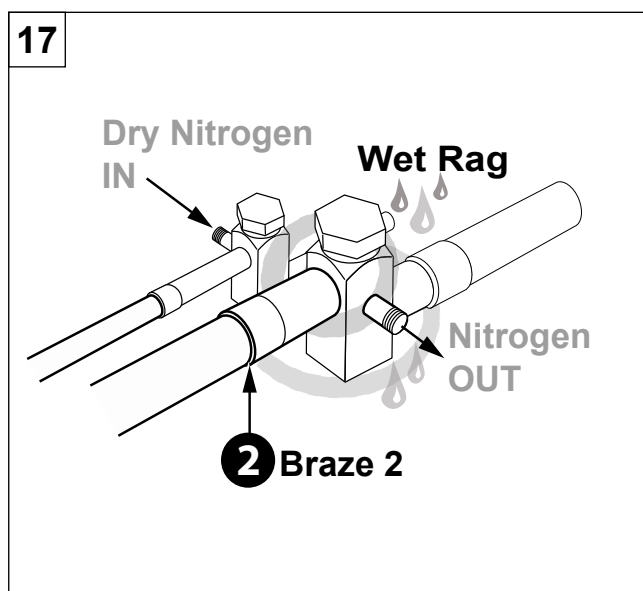
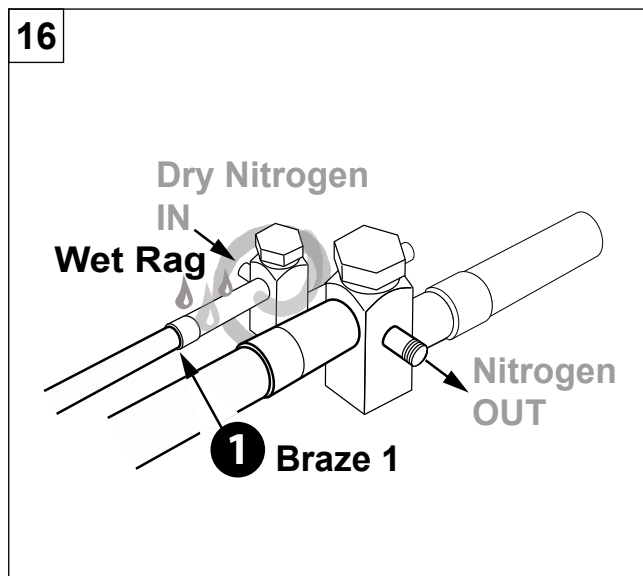

6.3.4 Refrigerant Line Leak Test

Test for leak

- Pressurize the refrigerant lines and indoor coil to 350-400 PSIG using dry nitrogen (Fig. 19). The nitrogen pressure must be maintained for a few minutes (15-30 min).
- If pressure decay is observed, it is an indication of leak(s).
- Check for leaks by using a soap solution at each brazed joint (Fig. 20).

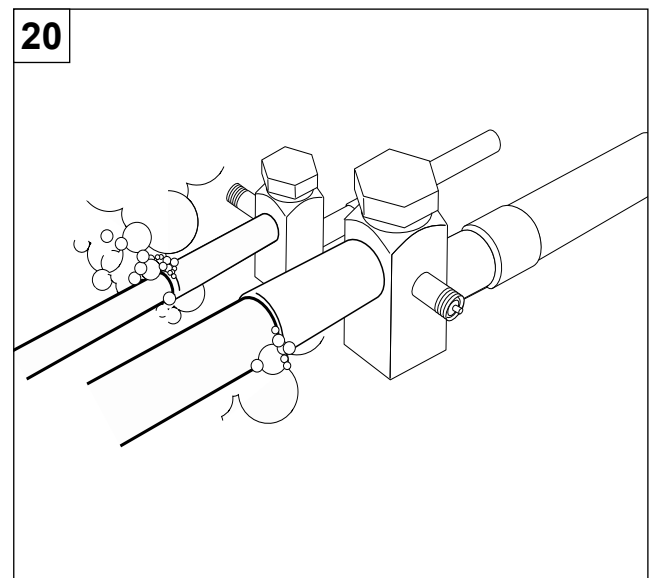
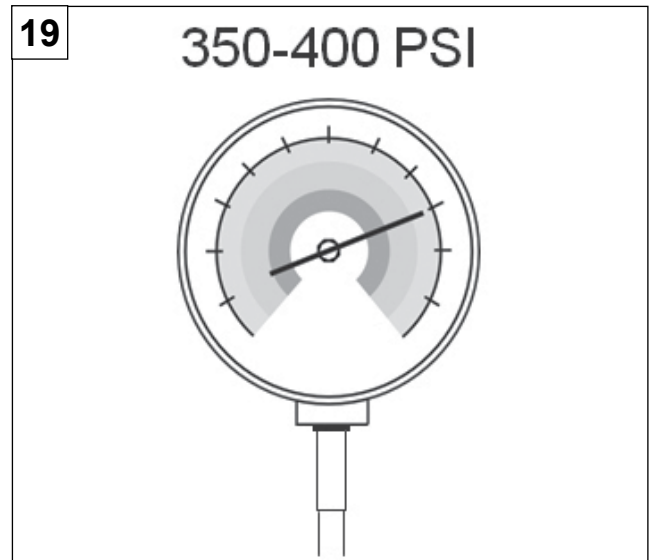

6.3.5 Refrigerant Line Insulation

- The Vapor Line must always be insulated (Fig. 21).
- DO NOT allow the liquid line and vapor line to come in direct (metal to metal) contact to each other.

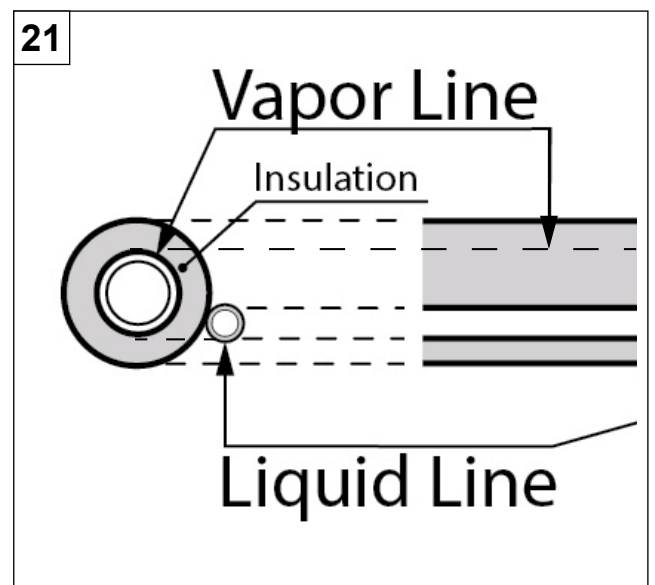

7. EVACUATION

7.1 EVACUATE THE REFRIGERANT LINES AND INDOOR COIL

⚠ WARNING ⚠

DO NOT OPEN THE SERVICE VALVES UNTIL THE REFRIGERANT LINES AND INDOOR COIL LEAK CHECK AND EVACUATION ARE COMPLETE. REFRIGERANT CAN LEAK AND MAY CAUSING MILD TO SEVERE BURNS.

- Connect the vacuum pump to evacuate the refrigerant line set and indoor coil.
- Evacuate until the micron gauge reads no higher than 350 microns or less (Fig. 22), then close **OFF** the valve to the vacuum pump.

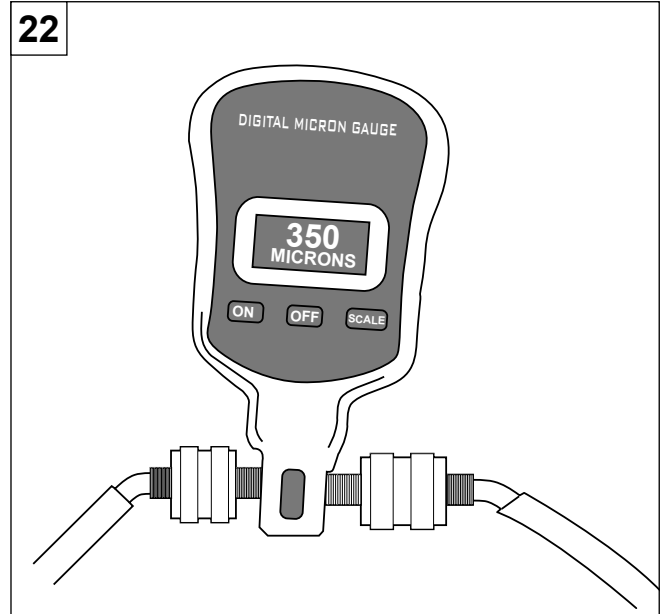

- Observe the micron gauge. Evacuation is complete if the micron gauge does not rise above 500 microns in one minute and no more the 1000 microns in 10 minutes (Fig. 23).
- When vacuum pressure rises more than 1000 microns but holds steady below 2000 microns it indicates the presence of moisture and/or non-condensable or presence of small leak. If vacuum pressure stays constantly at 2000 microns or it rises, it indicates the presence of leak.
- If the leak is found, perform the necessary repair and repeat the evacuation process.
- Once evacuation is complete, close the valves on the manifold gauge set, turn off and disconnect the vacuum pump.



8. SERVICE VALVES

IOM

8.1 OPEN THE SERVICE VALVES

⚠ WARNING ⚠

EXTREME CAUTION MUST BE EXERCISED WHEN OPENING THE LIQUID LINE SERVICE VALVE. TURN COUNTERCLOCKWISE UNTIL THE VALVE STEM JUST TOUCHES THE ROLLED EDGE. NO TORQUE IS REQUIRED. FAILURE TO FOLLOW THIS WARNING WILL RESULT IN ABRUPT RELEASE OF SYSTEM CHARGE AND MAY RESULT IN PERSONAL INJURY AND/OR PROPERTY DAMAGE.

⚠ IMPORTANT ⚠

LEAK CHECK AND EVACUATION MUST BE COMPLETED BEFORE OPENING THE SERVICE VALVES.

⚠ CAUTION ⚠

THE VAPOR LINE SERVICE VALVE MUST BE OPENED FIRST BEFORE OPENING THE LIQUID LINE SERVICE VALVE.

1. Remove the cap from vapor service valve (Fig. 24)
2. Fully insert Allen key into the stem and rotate counterclockwise until valve stem just touches the rolled edge.
3. Replace the valve stem cap. Tighten the cap finger tight with an additional 1/6 turn.
4. Repeat STEPS 1 - 3 for Liquid Service Valve.

24

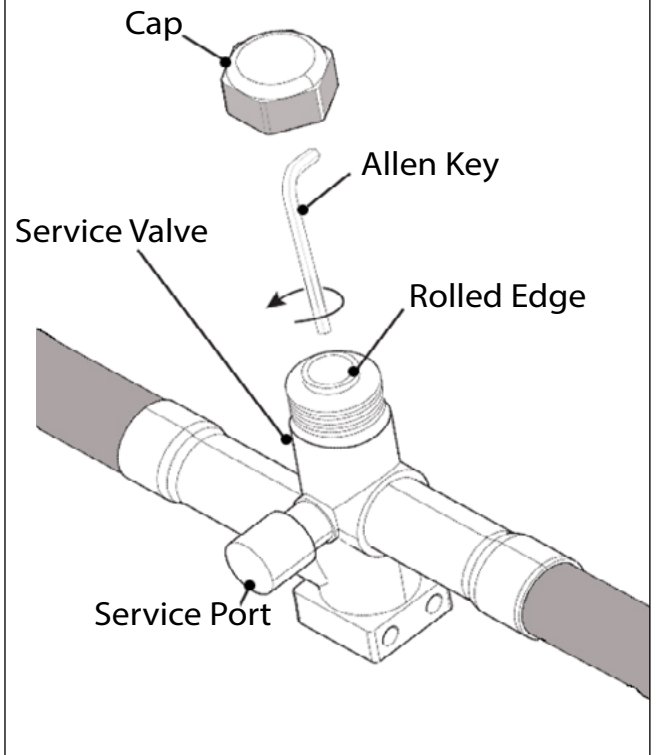

9. ELECTRICAL

⚠ WARNING ⚠

ONLY COPPER CONDUCTORS MUST BE USED FOR ALL FIELD WIRING AND BE IN ACCORDANCE WITH LOCAL, NATIONAL, FIRE, SAFETY AND ELECTRICAL CODES. THIS UNIT MUST BE GROUNDED WITH A SEPARATE GROUND WIRE IN ACCORDANCE WITH THE CODES MENTIONED ABOVE.

Make sure that electrical supply meets the values specified on the unit nameplate and wiring label. Power wiring, disconnect switches, control (low voltage) wiring and over current protection must be supplied by the installer. Wire size must be sized per National and Local Electrical codes requirements.

9.1 LOW VOLTAGE CONNECTIONS

Make sure that electrical supply meets the values specified on the unit nameplate and wiring label. Power wiring, disconnect switches, control (low voltage) wiring and over current protection must be supplied by the installer. Wire size must be sized per National and Local Electrical codes requirements.

9.2 HIGH VOLTAGE CONNECTIONS

⚠ WARNING ⚠

DURING INSTALLATION, TESTING, SERVICING, AND TROUBLESHOOTING OF THIS PRODUCT, IT MAY BE NECESSARY TO WORK WITH ELECTRICAL COMPONENTS. THERE IS A RISK OF ELECTRIC SHOCK THAT CAN CAUSE INJURY OR DEATH: DISCONNECT ALL REMOTE ELECTRIC POWER SUPPLIES BEFORE SERVICING.

⚠ WARNING ⚠

SHUT OFF ELECTRICAL POWER AT THE FUSE BOX OR SERVICE PANEL BEFORE MAKING ANY ELECTRICAL CONNECTIONS. FAILURE TO DO SO CAN CAUSE ELECTRICAL SHOCK RESULTING IN PERSONAL INJURY OR DEATH.

- THE HEAT PUMP CABINET MUST HAVE AN UNINTERRUPTED GROUND.
- A GROUND LUG IS PROVIDED IN THE ELECTRICAL JUNCTION BOX.
- DO NOT USE REFRIGERANT PIPING AS A GROUND.

FAILING TO GROUND THE HEAT PUMP_ PROPERLY CAN RESULT IN ELECTRIC SHOCK RESULTING IN PERSONAL INJURY OR DEATH.

9.2.1 High Voltage Power Supply

- The high voltage power supply must agree with the equipment nameplate located on the service panel cover (Fig. 25).
- Power wiring must comply with national, state, and local codes. The wiring diagram is located on the back side of the electrical cover.

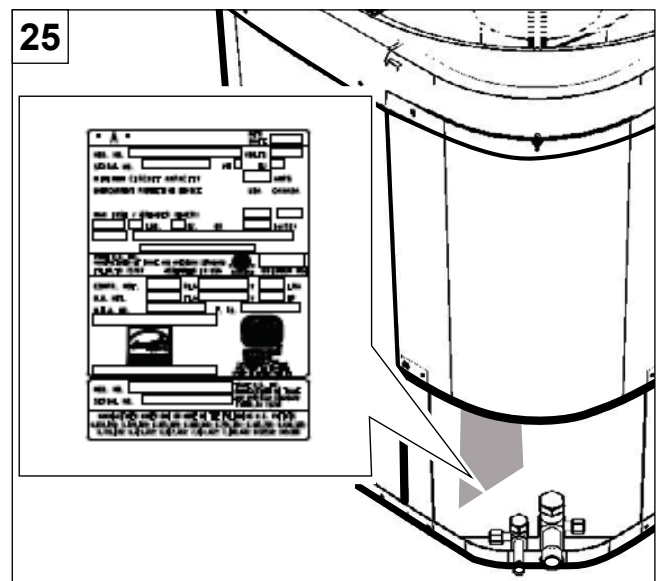

9.2.2 High Voltage Disconnect Switch

- Install a separate disconnect switch at the outdoor unit (Fig. 26).

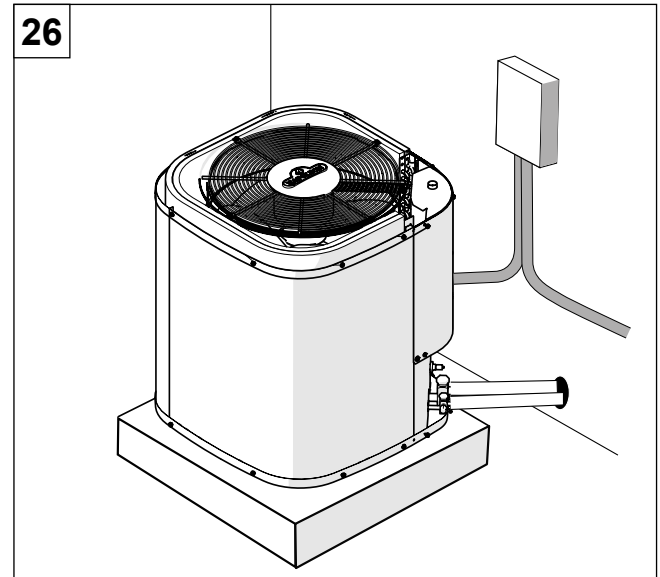

9.2.3 High Voltage Ground

Ground the outdoor unit per national, state, provincial and local code requirements (Fig. 27).

Components:

1. Contactor
2. Dual Run Capacitor
3. Ground Lug
4. Control Circuit Board

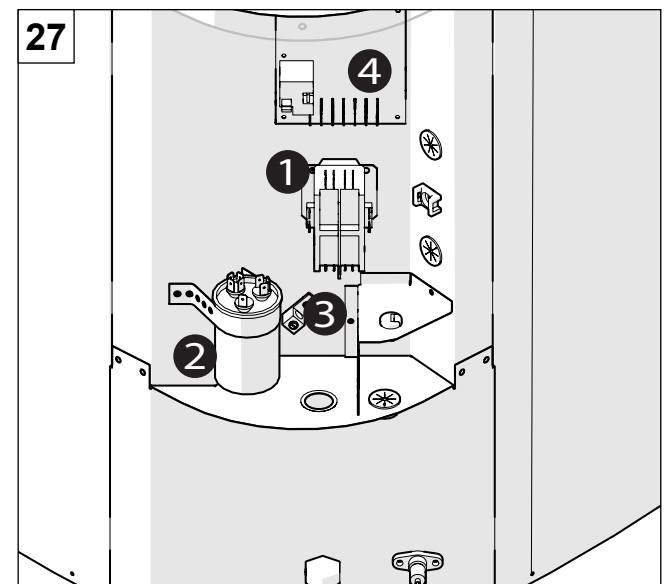

9.2.4 Thermostat

- Room thermostat (purchased separately) should be installed approximately in the center of the conditioned area on an INSIDE wall and 5 feet (1.5m) above the floor.
- Do NOT install thermostat on an outside wall or where it can be exposed to sunlight or drafts.

Good thermostat locations are:

- in a living room or dining room,
- in a position where the thermostat will be in natural air circulation (not dead air space) but where the thermostat will not be exposed to strong drafts from windows, doorways, or from a heating or cooling air

Bad Room Thermostat Locations:

- on an exterior building wall (exposed to outdoor temperature effects) where drafts from an exterior door will affect its reading
- above or in the line of airflow from a heating or cooling air supply register
- in direct sunlight
- in a kitchen, bath, or entry hallway or on a wall shared with a hot space such as a kitchen or boiler room
- in an alcove, behind an open door, behind furniture or next to concealed pipes or air ducts
- Do not place heat-emitting devices such as lamps or small appliances close to the thermostat. Their heat may affect its operation.

9.2.5 Wiring Diagram

WIRING DIAGRAM / SCHÉMA DE CÂBLAGE

WARNING: DISCONNECT ALL POWER SUPPLIES BEFORE SERVICING OR INSTALLING UNITS. FAILURE TO DO SO MAY CAUSE PROPERTY DAMAGE, PERSONAL INJURY OR DEATH.
 AVERTISSEMENT : DEBRANCHEZ TOUS LES CORDONS D'ALIMENTATION AVANT L'INSTALLATION OU L'ENTRETIEN D'UNE UNITÉ. LE NON RESPECT DE CETTE INDICATION PEUT ENTRÂÎNER DES DOMMAGES MATÉRIELS, DES BLESSURES OU LA MORT.
 USE COPPER WIRES / UTILISER DES FILS D'ALIMENTATION EN CUIVRE.

COMPONENT NAME / NOM DES COMPOSANTS

- CAP - DUAL CAPACITOR / CONDENSATEUR DOUBLE
- CCH - CRANKCASE HEATER / COURROIE DE CHAUFFAGE
- COMP - COMPRESSOR / COMPRESSEUR
- CONT - CONTACTOR / CONTACTEUR
- CM - OUTDOOR FAN MOTOR / MOTEUR DE VENTILATEUR EXTÉRIEUR
- DFT - DEFROST THERMOSTAT / THERMOSTAT DE DÉGIVRAGE
- GND LUG - GROUND LUG / COSSE DE MISE À LA TERRE
- HPCB - HEAT PUMP CONTROL BOARD / PANNEAU DE CONTRÔLE DE LA THERMOPOMPE
- HPS - HIGH PRESSURE SWITCH/COMMUTEUR HAUTE PRESSION
- HS - CRANKCASE HEATER THERMOSTAT SWITCH / COMMUTEUR DU THERMOSTAT DE LA COURROIE DE CHAUFFAGE
- LPS - LOW PRESSURE SWITCH / COMMUTEUR BASSE PRESSION
- RVC - REVERSING VALVE COIL / SERPENTIN DU ROBINET INVERSEUR
- DTS - DISCHARGE THERMOSTAT SWITCH / COMMUTEUR DE DÉCHARGE DU THERMOSTAT SENSOR - CAPTEUR

THERMOSTAT CONTROLLER (WIRE CONNECTION ONLY) / RÉGULATEUR DU THERMOSTAT (LIAISON PAR FIL SEULEMENT)

- O - HP CHANGEOVER VALVE, ENERGIZED CONSTANTLY IN COOLING / VALVE DE CHANGEMENT DE RÉGIME DE LA THERMOPOMPE, CONTINUUELLEMENT SOUS TENSION PENDANT LE REFRIGÉRISSMENT
- C - COMMON WIRE FROM SYSTEM TRANSFORM / CÂBLE NEUTRE DU TRANSFORMATEUR DU SYSTÈME
- Y - COMPRESSOR RELAY / RELAIS DU COMPRESSEUR
- G - FAN RELAY / RELAIS DU VENTILATEUR
- RH - POWER FOR COOLING / ALIMENTATION POUR LA CLIMATISATION
- RH - POWER FOR HEATING / ALIMENTATION POUR LE CHAUFFAGE
- L - ALARM FROM CONTROL BOARD (OPTION, NOT SHOWN) / ALARME DU PANNEAU DE CONTRÔLE (EN OPTION, NON ILLUSTRÉ)
- Y2 - 2ND STAGE COMPRESSOR (OPTION, NOT SHOWN) / CHALEUR DE DEUXIÈME STAGE (EN OPTION, NON ILLUSTRÉ)
- B - HP CHANGEOVER VALVE, ENERGIZED CONSTANTLY IN HEATING
- W2 - 2ND STAGE HEAT (OPTION, NOT SHOWN)
- W/E - HEAT RELAY/EMERGENCY HEAT RELAY (OPTION NOT SHOWN) / RELAIS DE CHAUFFAGE / RELAIS DE CHAUFFAGE D'URGENCE (EN OPTION, NON ILLUSTRÉ)
- 6 - 3 WIRE ZONE VALVE (OPTION, NOT SHOWN) / VALVE DE ZONE À TROIS CÂBLES (EN OPTION, NON ILLUSTRÉ)

COLOUR CODE / CODE DE COULEUR

- BK - BLACK / NOIR
- BL - BLUE / BLEU
- BR - BROWN / BRUN
- G - GREEN / VERT
- O - ORANGE / ORANGE
- R - RED / ROUGE
- V - VIOLET / VIOLET
- W - WHITE / BLANC
- Y - YELLOW / JAUNE

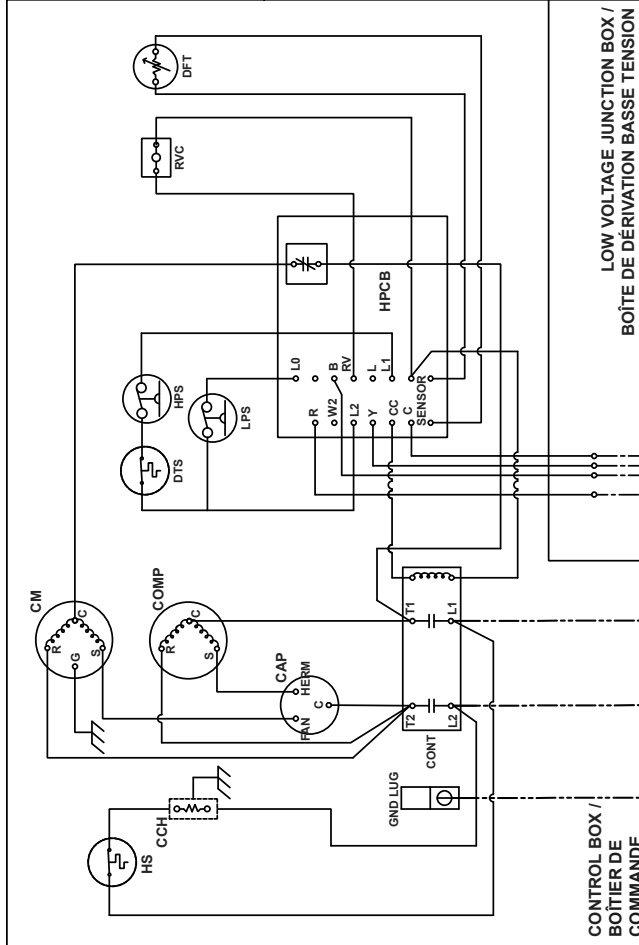

LOW VOLTAGE JUNCTION BOX / BOÎTE DE DERIVATION BASSE TENSION

THERMOSTAT WIRING (COOLING DEFAULT) / CÂBLAGE DU THERMOSTAT (CLIMATISATION PAR DÉFAUT)

LEGEND / LÉGENDE

- OPTIONAL WIRING / FILAGE OPTIONNEL
- LOW VOLTAGE FIELD WIRING / FIL BASSE TENSION
- HIGH VOLTAGE FIELD WIRING / FIL HAUTE TENSION

10. START UP

IOM

Perform the following steps:

1. Set System Thermostat to OFF (Fig. 29).

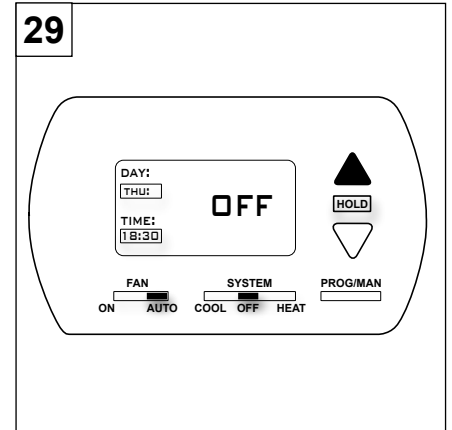

2. Turn disconnect switch ON (Fig. 30) to apply power to the indoor and outdoor units.

**Wait:**

3. Wait one (1) hour before starting the unit, if outdoor ambient temperature is below 70°F. Refer to (Fig. 31).

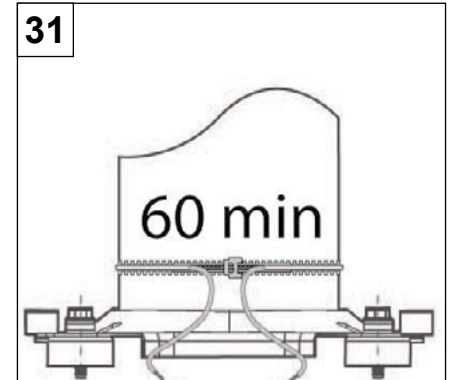

4. Set system thermostat to ON (cool or heat mode) Refer to (Fig. 32).

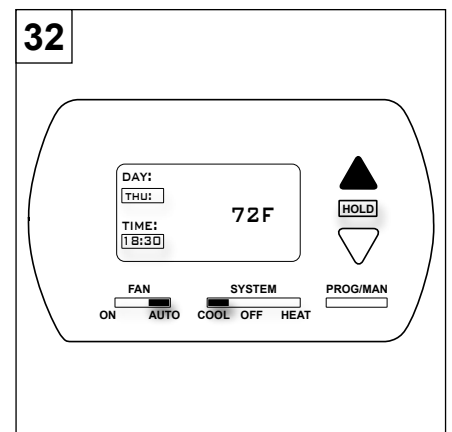

11. SYSTEM CHARGE ADJUSTMENT

⚠ WARNING ⚠

REFRIGERANT CHARGING MUST ONLY BE ATTEMPTED BY QUALIFIED CONTRACTORS. IMPROPER SYSTEM CHARGE CAN REDUCE SYSTEM CAPACITY AND MAY CAUSE EQUIPMENT DAMAGE.

11.1 SYSTEM TOTAL CHARGE

⚠ WARNING ⚠

DO NOT LEAVE THE SYSTEM OPEN TO THE ATMOSPHERE. DO NOT ATTEMPT TO PUMP "TOTAL SYSTEM CHARGE" INTO OUTDOOR UNIT FOR MAINTENANCE, SERVICE, ETC. THIS MAY CAUSE DAMAGE TO THE COMPRESSOR AND/OR OTHER COMPONENTS. THE OUTDOOR UNIT ONLY HAS ENOUGH VOLUME FOR THE "FACTORY CHARGE", NOT FOR THE "TOTAL SYSTEM CHARGE". IT IS UNLAWFUL TO KNOWINGLY VENT, RELEASE OR DISCHARGE REFRIGERANT INTO THE OPEN AIR DURING REPAIR, SERVICE, MAINTENANCE, OR THE FINAL DISPOSAL OF THIS UNIT.

All Heat Pump units come pre-charged with enough refrigerant for an appropriately matched indoor unit. For field installed line set, a correction of 0.6oz of R-410A per foot of line set is required for 3/4" suction line diameter and 0.7oz of R-410A per foot of line set required for 7/8" suction line diameter. Liquid line shall be 3/8" diameter. Using indoor unit that have not been approved as a match by the manufacturer is not recommended. To adjust the system charge to achieve the proper operating parameter, please follow the section 11.2.

NOTE

To obtain an efficient system matching AHRI performance, units with either thermostatic expansion valves or piston flow raters must be installed in the vertical direction with the liquid refrigerant flowing downwards or upwards, feeding the indoor coil. The capillary tubes and expansion valve location can be adjusted to ensure that the flow through both of the slabs of the A-Coil have equal flow of refrigerant. If the temperature difference does not vary more than 10°F between the two slabs of A-coil, it indicates the equal flow of refrigerant through each of the slabs.

11.2 ADJUSTING SYSTEM CHARGE FOR SYSTEMS USING THERMOSTATIC EXPANSION VALVES

11.2.1 Final Charge Adjustment

The outdoor temperature must be 60°F or higher. Set the room thermostat to COOL, fan switch to AUTO, and set the temperature control well below room temperature.

After system has stabilized per startup instructions, check subcooling and superheat as detailed in the following section:

Procedure:

1. Connect charging hose from liquid port on the refrigerant bottle to charging service port on manifold gauge.
2. Open refrigerant bottle and purge hose.
3. Connect low side of manifold gauge set to the pressure port on vapor line service valve.
4. Connect the high side of the manifold gauge set to pressure port on liquid line service valve.
5. Temporarily install a temperature measuring device on the liquid line near the liquid service valve and one at the vapor line near the vapor service valve. Ensure that the temperature measuring device makes adequate contact and insulated for accurate readings.
6. Operate the system for at least 10 minutes.
7. Check subcooling and superheat. Systems using thermostatic expansion valves should have a subcooling of 7°F to 9°F.
8. Record Total Charge on the nameplate and manual.

Check the nameplate for unit specific designed subcooling

- i. If subcooling and superheat are low, adjust the TXV to 7°F to 9°F superheat.
- ii. If subcooling is low and superheat is high or normal, add charge to raise the subcooling to 7°F to 9°F.
- iii. If subcooling and superheat are high, adjust the TXV to 7°F to 9°F superheat.
- iv. If subcooling is high and superheat is low or normal, remove charge to lower the subcooling to 7°F to 9°F.

11.3 RECORD SYSTEM INFORMATION

Record system pressures and temperatures after charging is complete. The total system charge shall be marked on the outdoor unit nameplate.

Model Number = _____
Serial Number = _____
Name Plate Voltage = _____ Measured Voltage = _____
Rated Amps : _____ Compressor Amps : _____ Outdoor Fan Amps: _____
Measured Outdoor Ambient = _____ °F
Outdoor Leaving Air Temperature = _____ °F
Indoor Air CFM = _____
Indoor Temp = _____ °F DB _____ °F WB
Air Leaving Indoor Coil Temperature = _____ °F DB _____ °F WB
Measured Liquid Line Temp = _____ °F
Measured Suction Line Temp = _____ °F
Liquid Gage Pressure = _____ PSIG
Suction Gage Pressure = _____ PSIG
Total System Charge = _____ OZ

12. CHECKOUT PROCEDURES

Final phases of this installation are the unit Operational and Checkout Procedures. To obtain proper performance, all units must be operated and charge adjustments made.

12.1 INSTRUCTING THE OWNER

- Assist owner with processing warranty cards and/or online registration.
- Review Owners Guide and provide a copy to the owner and guidance on proper operation and maintenance. Instruct the owner or the operator how to start, stop and adjust temperature setting.
- Instruct the owner on proper operation and maintenance of all other system components.

⚠ IMPORTANT ⚠
PERFORM A FINAL UNIT INSPECTION TO BE SURE THAT FACTORY TUBING HAS NOT SHIFTED DURING SHIPMENT. ADJUST TUBING IF NECESSARY SO TUBES DO NOT RUB AGAINST EACH OTHER WHEN THE UNIT RUNS. ALSO BE SURE WIRING CONNECTIONS ARE TIGHT AND WIRE ROUTING IS SECURE.

12.2 CHECKOUT PROCEDURE

Procedure

1. Check that unit is not damaged..... []
2. Leak check refrigerant lines..... []
3. Properly insulate suction line []
4. Ensure that lines are rated for R410A..... []
5. Properly secure and isolate all refrigerant lines..... []
6. Seal passages through masonry..... []
7. Verify that all electrical connections are tight. []
8. Verify outdoor coil is not blocked by foreign objects []
9. Observe outdoor fan during on cycle for clearance and smooth operation..... []
10. Indoor coil drain line drains freely..... []
11. Supply registers and return grilles are open and unobstructed..... []
12. Return air filter is installed. []
13. Correct airflow setting is used on Indoor blower motor []
14. Operate complete system in each mode to ensure safe operation. []
15. System information recorded..... []
16. Instruct the owner on proper operation and fill out Warranty documentation []

NOTE
INSTALLER SHOULD PLACE UNIT DATA SHEET AND INSTALLATION INSTRUCTION IN CUSTOMER PACKET AND GIVE TO HOME OWNER AFTER INSTALLATION IS COMPLETE.

12.3 SYSTEM OPERATION CHECKOUT PROCEDURE

Procedure

1. With thermostat set to the OFF position, close disconnect switch or switches to complete circuits to outdoor unit and furnace. Set thermostat to call for cooling.
2. After the system starts, check the voltage and amperage at the outdoor unit contactor.
3. If voltage is not within 10% of rated voltage, contact the local power company for corrections - unsatisfactory performance may result.
4. If amperage greatly exceeds nameplate amperage, shut down the system and contact dealer.
5. With the system in operation, check the outdoor unit for unusual noise and vibration.
6. Allow the system to operate until it is balanced or stabilized (approximately 20 minutes), before making further checks.
7. Ensure that all refrigerant in the hoses is returned to the system before removing manifold gage hoses.
8. Remove manifold gage hoses, and install caps on service valves.

13. HEAT PUMP TROUBLESHOOTING

13.1 DIAGNOSTIC CHART FOR COOLING MODE

TABLE 4.

DIAGNOSTIC CHART FOR COOLING MODE		
WARNING!	THIS TROUBLESHOOTING GUIDE IS INTENDED FOR USE BY QUALIFIED SERVICE PERSONNEL ONLY!	
FAULT CONDITION	POSSIBLE CAUSE	CORRECTION
No cooling, outdoor unit not running, indoor fan running	Outdoor disconnect switch opened	- Close disconnect switch.
	Fuse or breaker opened	- Replace fuse, reset breaker
	Faulty wiring	- Repair or replace faulty wiring and inspect connections
No cooling; indoor fan and outdoor unit will not run	<u>Low-voltage control problem:</u>	
	1. Thermostat	1. Repair loose connections or replace thermostat
	2. Interconnecting, wiring, or connections	2. Repair or replace wiring or connections.
	3. Transformer	3. Replace if defective.
No cooling; indoor and outdoor fan running, but compressor not running	<u>Tripped compressor internal overload:</u>	
	A. Low line voltage	- Correct low voltage - Call power company - Repair loose connections
	B. High head pressure:	
	- Dirty outdoor coil (condenser)	- Clean outdoor coil
	- Outdoor coil fan not running all the time	- Check outdoor coil fan motor and capacitor.
	- Outdoor coil air re-circulating	- Correct recirculation problem.
	- Overcharge of refrigerant	- Correct charge.
	C. Low charge, motor not properly cooled	Correct charge; if due to leak, repair leak.
Indoor coil freezing	Restricted airflow	- Change filters. - Open all supply register dampers. - Clear return air blockage. - Clean fan blades. - Speed fan up to higher speed.
	Low charge	- Adjust unit charge—repair leak if refrigerant has been lost.
	Metering device	- Change or clean metering device.
	Restricted filter drier	- Change filter drier.

13.2 DIAGNOSTIC CHART FOR HEATING MODE

TABLE 5.

DIAGNOSTIC CHART FOR HEATING MODE		
WARNING!	THIS TROUBLESHOOTING GUIDE IS INTENDED FOR USE BY QUALIFIED SERVICE PERSONNEL ONLY!	
FAULT CONDITION	POSSIBLE CAUSE	CORRECTION
No heat - outdoor unit will not run - indoor fan runs	Outdoor Disconnect Open	- Close disconnect.
	Fuse or breaker Open	- Replace fuse, reset breaker, and diagnose
	Faulty wiring	- Repair or replace wiring or connections.
No heat - indoor fan and outdoor unit will not run	<u>Low-voltage control problem:</u>	
	A. Thermostat	- Repair loose connections or replace thermostat
	B. Interconnecting—wiring or connections	- Repair or replace wiring or connections.
	C. Transformer	- Replace if defective.
No heating; indoor and outdoor fans running, but compressor not running	<u>Compressor overload tripped:</u>	
	A. Low line voltage	Correct low voltage, call power company, or correct loose connections.
	B. High head pressure:	
	1) Dirty indoor (condenser) coil	- Clean indoor coil.
	2) Indoor fan not running all the time	- Check indoor fan motor and capacitor.
	3) Overcharge of refrigerant	- Correct charge.
Outdoor coil (evaporator) freezes and ice will not melt	Defrost control sequence not operating	- Check defrost sequence and correct if necessary.
	Low charge, not enough refrigerant to perform adequate defrost	- Correct charge and run unit through enough defrost cycles to clear ice off; then allow unit to run normally.
	4) Restricted indoor airflow	- Change filters. - Open all supply registers. - Clear return air blockage.
Unit will not change from cooling to heating or heating to cooling	<u>Four-way valve not changing over :</u>	
	A. Defective defrost relay or circuit board	- Replace relay or circuit board.
	B. Four-way valve stuck	- Change four-way valve.
	C. Thermostat not changing to heat	- Repair or replace

14. MAINTENANCE

IOM

14.1 INDOOR

1. Check air filters and replace if necessary.
2. The indoor coil should be inspected annually for blockages.
3. Vacuum or spray the coil fins with clean water to remove dust and dirt.
4. Refer to the furnace or air handler instructions for filter and blower motor maintenance.
5. The indoor coil and drain pan should be inspected and cleaned regularly to prevent odors and bacterial growth and to assure proper drainage.

14.2 OUTDOOR

- Check the heat pump annually for blockages and remove foreign objects blocking the heat pump.

⚠ CAUTION ⚠

DO NOT USE COIL CLEANERS TO CLEAN OUTDOOR COIL. CLEANERS CONTAINING HYDROGEN FLUORIDE, HYDROXIDES, CHLORIDES, AND SULFATES CAN GREATLY REDUCE THE LIFETIME OF THE COPPER-TUBE-ALUMINUM-FIN COIL.

- Clean the heat pump coil by spraying it with clean water from a garden hose.
- Avoid wetting any electrical controls.
- The outdoor fan motor is permanently lubricated and does not require periodic oiling.

⚠ CAUTION ⚠

BE SURE THE UNIT DISCONNECT IS IN THE OFF POSITION AND THAT ALL ELECTRICAL POWER TO THE UNIT IS TURNED OFF BEFORE CLEANING THE SYSTEM.

If unit is not operating properly, check the following items:

- The indoor section for dirty filter and outdoor section for blockage.
- If the compressor has shutdown on thermal-overload, it may be necessary to wait for the compressor to cool down before the unit will restart.
- If the temperature setting on the thermostat is low enough to bring the heat pump ON and system still does not start, call a service technician.

⚠ CAUTION ⚠

IT IS UNLAWFUL TO KNOWINGLY VENT, RELEASE OR DISCHARGE REFRIGERANT INTO THE OPEN AIR DURING REPAIR, SERVICE, MAINTENANCE, OR THE FINAL DISPOSAL OF THIS UNIT.

15. OWNER'S SERVICE INFORMATION

TABLE 6.

HOMEOWNER'S REFERENCE TABLE
Model No.
Serial No. <i>(serial number located on bottom of inside door)</i>
Date Installed
Contractor
Contact
Address
Postal Code/Zip Code
Telephone No.
After Hours No.
If different from Installation Contractor:
Service Tech.
Telephone No.
After Hours No.
NOTE:

H28.1

Appliance Service History

This heater must be serviced annually depending on usage.

Date	Dealer Name	Service Technician Name	Service Performed	Special Concerns

16. WARRANTY

Wolf Steel Ltd. products are manufactured under the strict Standard of the world recognized ISO 9001 : 2008 Quality Assurance Certificate. Wolf Steel Ltd. products are designed with superior components and materials assembled by trained craftsmen who take great pride in their work. The complete appliance is thoroughly inspected by a qualified technician before packaging to ensure that you, the customer, receives the quality product that you expect from Wolf Steel Ltd.

NAPOLEON SPLIT HEAT PUMP LIMITED WARRANTY

The Napoleon Split Heat Pumps are warranted by Wolf Steel Ltd. to be free from defects in materials and workmanship under normal use and maintenance.

PRESIDENT'S LIMITED WARRANTY (Registered)

To the original registered owner and his or her spouse ("owner"), the **Napoleon Split Heat Pump** is warranted for **10 YEARS in the home** which the unit was originally installed, except as provided below. These warranties apply only if:

- The unit is installed in an owner-occupied, primary single family residence, and
- The warranty is registered with **Wolf Steel Ltd.** online within 60 days after the original installation or possession of a new home.

OR

LIMITED WARRANTY (Not Registered)

If not registered, **all parts**, including the compressor are warranted for a period of **5 YEARS**. Should a part fail due to defect within the first year, Wolf Steel Ltd. reserves the right to replace the defective part or the entire outdoor unit assembly at company's discretion. Diagnostics, transportation or labor charges related to warranty repair is not covered.

* Construction of models varies. Warranty applies only to components included with your specific appliance.

WARRANTY REGISTRATION

To register, go to www.napoleonheatingandcooling.com or by phone: **1-866-820-8686**. Some states and provinces do not allow limitations on how long an implied limited warranty lasts or do not allow the exclusion or limitation of incidental or consequential damages, so the limitations or exclusions may not apply to you. This limited warranty gives you specific legal rights, and you may also have other rights which vary by jurisdiction.

CONDITIONS AND LIMITATIONS

Warranty claims must be authorized by Wolf Steel Ltd. recognized representative or agent; parts/components being claimed may need to be analyzed at a Wolf Steel Ltd. facility. Records of installation date and periodic maintenance are required to process claim. All warranty service must be done by Wolf Steel Ltd. authorized service technicians using approved components.

Returned products are to be shipped prepaid to the manufacturer for investigation. If a product is found to be defective, the manufacturer will repair or replace such defect. Before shipping your appliance or defective components, your dealer must obtain an authorization number. Any merchandise shipped without authorization will be refused and returned to sender. Shipping costs are not covered under this warranty. Additional service fees may apply if you are seeking warranty service from a dealer.

Limitations:

Wolf Steel Ltd. is not responsible for:

1. Damages/Repairs/Costs incurred due to faulty installation or application.
2. Damages/Repairs/Costs caused by an installation that is not performed in compliance with all federal, provincial/state laws or regulations, and the Installation and Operation Manual.
3. Damage as a result of vandalism, freight damage, floods, fires, winds, lightning, and accidents, or any act of nature. Atmospheres contaminated by compounds of chlorine, halogenated hydrocarbons, or other damaging chemicals causing deterioration of components, or other conditions beyond the control of Wolf Steel.
4. Use of components or accessories not compatible with this appliance.
5. Products installed outside of Canada and the United States and its territories.
6. Routine maintenance, but not limited to, cleaning of the coils, filter cleaning and/or replacement and lubrication.
7. Damages/Repairs/Costs incurred because of the use of Parts not supplied or previously authorized by Wolf Steel.
8. Damages or repairs required as a result of improper use, maintenance, operation, servicing, cleaning or replacing filters.
9. Failure to operate due to interruption and/or inadequate electrical service.
10. Damages, defects or failures caused by accidents or negligent or unreasonable use or operation of the unit and its' components, including without limitation, operation beyond rated capacity and operation of electrical components at voltage other than that specified on the rating plate.
11. Wolf Steel will not in any event extend warranty coverage to any incidental, consequential or indirect damages.
12. Changes in the appearance of the unit that does not affect its performance.
13. Damages, defects or failures caused by operation of the unit in abnormal environmental conditions (i.e. salt air).
14. Damages, defects or failures caused by operating air conditioning modules during periods when outdoor ambient temperatures fall below 13°C/55°F.

ALL SPECIFICATIONS AND DESIGNS ARE SUBJECT TO CHANGE WITHOUT PRIOR NOTICE DUE TO ON-GOING PRODUCT IMPROVEMENTS. Napoleon® IS A REGISTERED TRADEMARK OF WOLF STEEL LTD. PATENTS U.S. 5.303.693.801 - CAN. 2.073.411, 2.082.915 © WOLF STEEL LTD.

FOR HOMEOWNERS FUTURE REFERENCE

Model and Serial Number _____
 (Serial number located on inside bottom door)

Installation Date _____

Dealer Name _____

Dealer's City/Province-State/Postal-Zip Code _____

Telephone/Fax _____

E-mail Address _____

For further information about this warranty, contact Wolf Steel Ltd. Customer Solutions Department by • phone (866) 820-8686 • by email: hvac@napoleonproducts.com • or mail to **WOLF STEEL***, 24 Napoleon Road, Barrie, Ontario L4M 0G8 Canada



www.napoleonheatingandcooling.com

Other Napoleon Products



Fireplace Inserts • Charcoal Grills • Gas Fireplaces • Waterfalls • Wood Stoves
Heating & Cooling • Electric Fireplaces • Outdoor Fireplaces • Gas Grills



24 Napoleon Road, Barrie, Ontario, Canada L4M 0G8
214 Bayview Drive, Barrie, Ontario, Canada L4N 4Y8
103 Miller Drive, Crittenden, Kentucky, USA 41030
7200 Trans Canada Highway, Montreal, Quebec, Canada H4T 1A3

Fireplaces / Heating & Cooling call: 705-721-1212 • Grills call: 705-726-4278
napoleonproducts.com

W415-1656 / 03.17.2017

