

This Owner's Manual is provided and hosted by [Appliance Factory Parts](#).



Napoleon CCGM015A Owner's Manual

[Shop genuine replacement parts for Napoleon
CCGM015A](#)



[Find Your Napoleon HVAC Parts - Select From 105 Models](#)

----- Manual continues below -----

Technical Specifications



CONFORMS TO ANSI/UL STD. 1995, ANSI STD. Z21.47
CERTIFIED TO CAN/CSA STD. C22.2 NO. 236,
CAN/CSA STD. 2.3 AND CAN/CGA STD. 2.17

PSC - SERIES Gas Heat / Electric Cooling

Self contained, high efficiency Thru-The-Wall heating & cooling unit
Up to 96.8% AFUE, 90% Thermal Efficiency, AHRI Certified
Input 15 000 - 50 000 Btu/h

FEATURES

COMPATIBLE BOX SIZE



- Industry standard footprint for retrofit applications
- Appliance shell dimensions:
43 1/8" High x 28" Wide x 32" Deep
- Wall Sleeve dimensions where penetrating exterior wall:
44 7/8" High x 28 7/8" Wide
- Standard TAUPE color
- Custom color options are available

HEATING FEATURES

- Up to 96.8% AFUE, 90% Thermal Efficiency Condensing, Single Stage Gas Furnace
- Stainless steel heat exchanger
- Sealed burner tray – keeps cold external air from circulating in vestibule
- Clear front manifold condensate cover for easy inspection and service troubleshooting

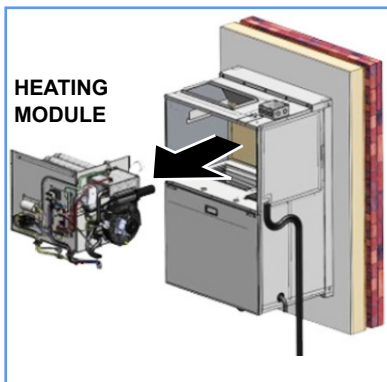

CIRCULATION BLOWER

- Dual Inlet Blower for higher flow rates / reduced air noise
- Endura Pro Multi-Speed Electronically Commutated Motor for increased electrical efficiency

COOLING FEATURES

- Up to 10.8 EER
- R-410A Refrigerant System
- Micro-Channel Condenser and Evaporator Coils
- High Efficiency Copeland Scroll Compressors

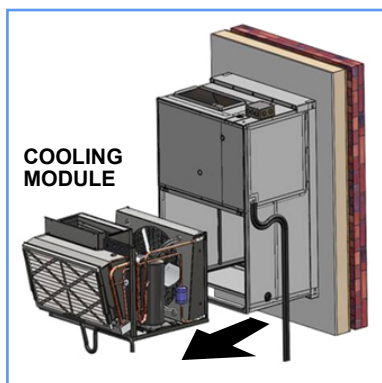

SERVICE ADVANTAGES

- Indoor access to all parts & maintenance needs
- Innovative, dual slide-out chassis can be partially or fully removed for efficient servicing
- With spare modules, building management can perform quick swap outs, maintaining indoor conditions in the apartment/condo, while troubleshooting non functioning units off line
- Can perform direct replacement of the individual modules at the end of their service life instead of replacement of the complete appliance
- All control harnesses are separated with modular quick disconnects so module swap outs do not require time consuming rewiring

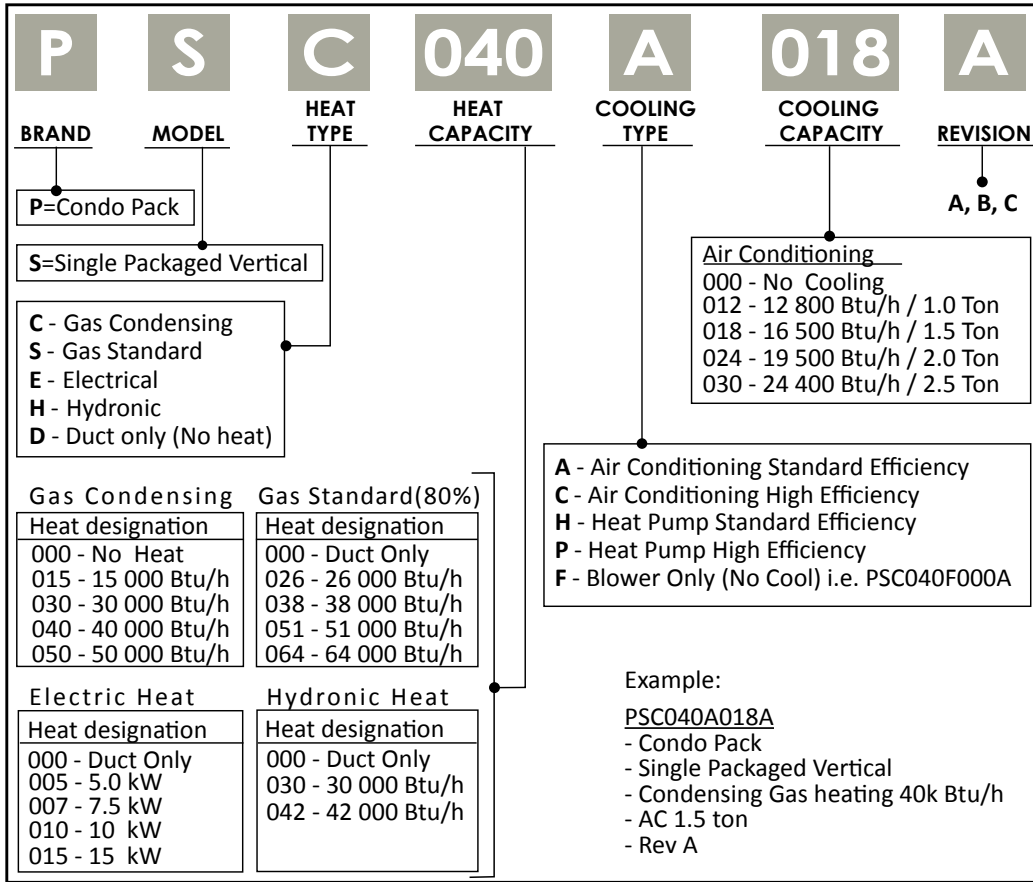

SPECIFICATIONS

PERFORMANCE

HEATING	PSC015A012A	PSC015A018A	PSC015A024A	PSC015A030A	PSC030A012A	PSC030A018A	PSC030A024A	PSC030A030A
Thermal Efficiency	90%	90%	90%	90%	90%	90%	90%	90%
AFUE	96.8%	96.8%	96.8%	96.8%	93%	93%	93%	93%
Input BTU/H	15,000	15,000	15,000	15,000	30,000	30,000	30,000	30,000
Output BTU/H (Thermal Efficiency)	14,520	14,520	14,520	14,520	27,000	27,000	27,000	27,000
Output BTU/H (AFUE)	13,500	13,500	13,500	13,500	27,900	27,900	27,900	27,900
COOLING								
BTU/H	12,800	16,500	19,500	24,400	12,800	16,500	19,500	24,400
EER	10.8	9.6	9.0	9.0	10.8	9.6	9.0	9.0
REF.	410A	410A	410A	410A	410A	410A	410A	410A
WEIGHT (lb)	328	349	349	349	328	349	349	349

HEATING	PSC040A012A	PSC040A018A	PSC040A024A	PSC040A030A	PSC050A012A	PSC050A018A	PSC050A024A	PSC050A030A
Thermal Efficiency	90%	90%	90%	90%	90%	90%	90%	90%
AFUE	91.7%	91.7%	91.7%	91.7%	90.6%	90.6%	90.6%	90.6%
Input BTU/H	40,000	40,000	40,000	40,000	50,000	50,000	50,000	50,000
Output BTU/H (Thermal Efficiency)	36,000	36,000	36,000	36,000	45,000	45,000	45,000	45,000
Output BTU/H (AFUE)	36,680	36,680	36,680	36,680	45,300	45,300	45,300	45,300
COOLING								
BTU/H	12,800	16,500	19,500	24,400	12,800	16,500	19,500	24,400
EER	10.8	9.6	9.0	9.0	10.8	9.6	9.0	9.0
REF.	410A	410A	410A	410A	410A	410A	410A	410A
WEIGHT (lb)	328	349	349	349	328	349	349	349

AIR FLOW

----- CFM AT EXTERNAL STATIC PRESSURE, INCHES WATER COLUMN --													
MODEL	HEATING	SETTING	Speed Tap#	0.1	0.2	0.3	0.4	0.5	0.6	0.7	0.8	0.9	1.0
CCGM015A	15 kBTU/H	Factory	5	439	388	333	294	240	193	-	-	-	-
		High	4	569	529	494	470	415	368	346	306	273	-
CCGM030A	30 kBTU/H	Factory	4	569	529	494	470	415	368	346	306	273	-
		High	3	771	744	729	704	693	663	644	610	566	556
CCGM040A	40 kBTU/H	Factory	3	771	744	729	704	693	663	644	610	566	556
		High	2	924	908	886	868	839	804	757	696	617	-
CCGM050A	50 kBTU/H	Factory	2	924	908	886	868	839	804	757	696	617	-
		High	1	1010	971	938	906	870	824	773	713	617	-
MODEL	COOLING	SETTING											
CACM012A	1.0 TON	Factory	5	439	388	333	294	240	193	-	-	-	-
		High	4	569	529	494	470	415	368	346	306	273	-
CACM018A	1.5 TON	Factory	3	771	744	729	704	693	663	644	610	566	566
		High	2	924	908	886	868	839	804	757	696	617	-
CACM024A	2.0 TON	Factory	3	771	744	729	704	693	663	644	610	566	566
		High	2	924	908	886	868	839	804	757	696	617	-
CACM030A	2.5 TON	Factory	2	1010	971	938	906	870	824	773	713	617	-

ELECTRICAL

Description	1.0 TON	1.5 TON	2.0 TON	2.5 TON
Compressor Type	Rotary	Scroll	Scroll	Scroll
Rated Amps	5.5	9	13.5	12.8
LRA	26	48	58.3	64
MCA	10.7	15.1	20.7	20.3
Max Fuse/Breaker (A)	15	20	30	30
Indoor Fan FLA / HP / RPM	2.8 / 1/3 / 1050	2.8 / 1/3 / 1050	2.8 / 1/3 / 1050	2.8 / 1/3 / 1050
Condenser Fan FLA / HP / RPM	1.0 / 1/6 / 1075	1.0 / 1/6 / 1075	1.0 / 1/6 / 1075	1.5 / 1/4 / 1075
Combustion Fan FLA	1.25	1.25	1.25	1.25

GAS CONTROLS AND ADDITIONAL DATA		
IGNITION SYSTEM	SPARK IGNITION	
GAS CONNECTION	1/2" NPT	
CONDENSATE HOSE SIZE (Supplied)	1/2" ID and 5/8" ID	3/4" ID

*All specifications and designs can change without notice to allow for on-going improvements. Images may not be exactly as shown. Consult with your owner's manual for current information. Check all local and national building codes and gas regulations. Napoleon® is a registered trade mark of Wolf Steel Ltd.

Wolf Steel Ltd., 24 Napoleon Rd., Barrie, ON L4M 0G8 Canada • phone 866-820-8686 • fax 705-725-1150 • www.napoleonheatingandcooling.com
W415-1318 / A / 02.05.16

WALL SLEEVE DIMENSIONS

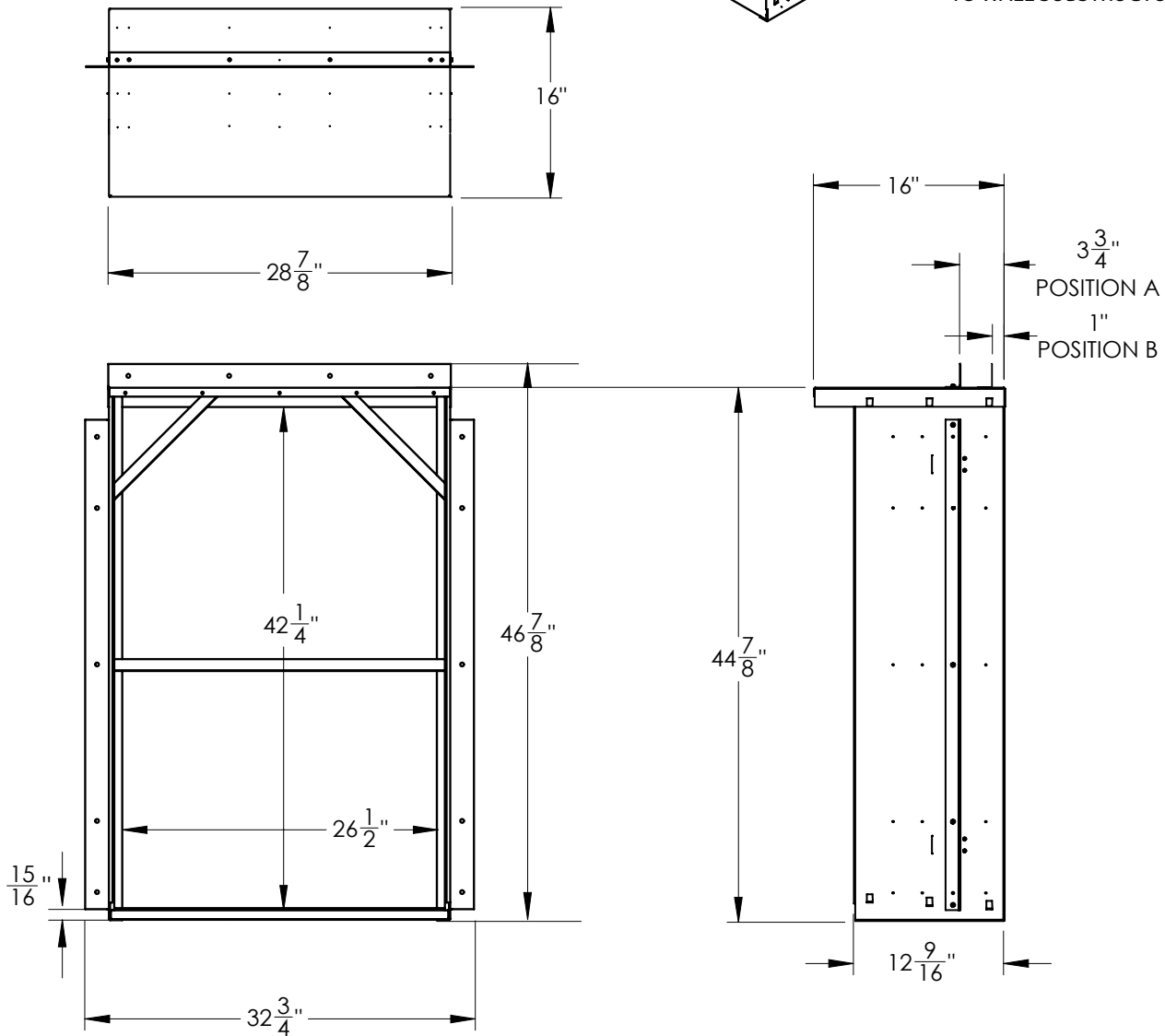
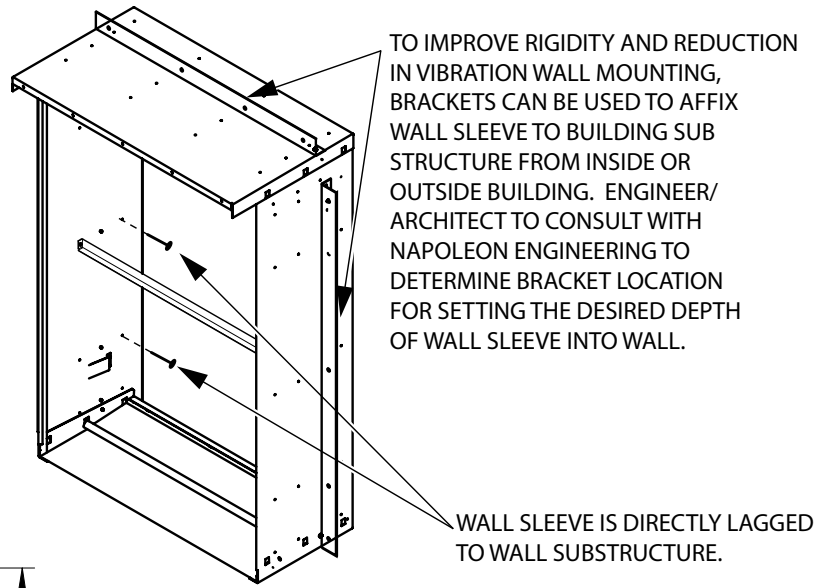

ENCLOSURE FOR CONDO PACK

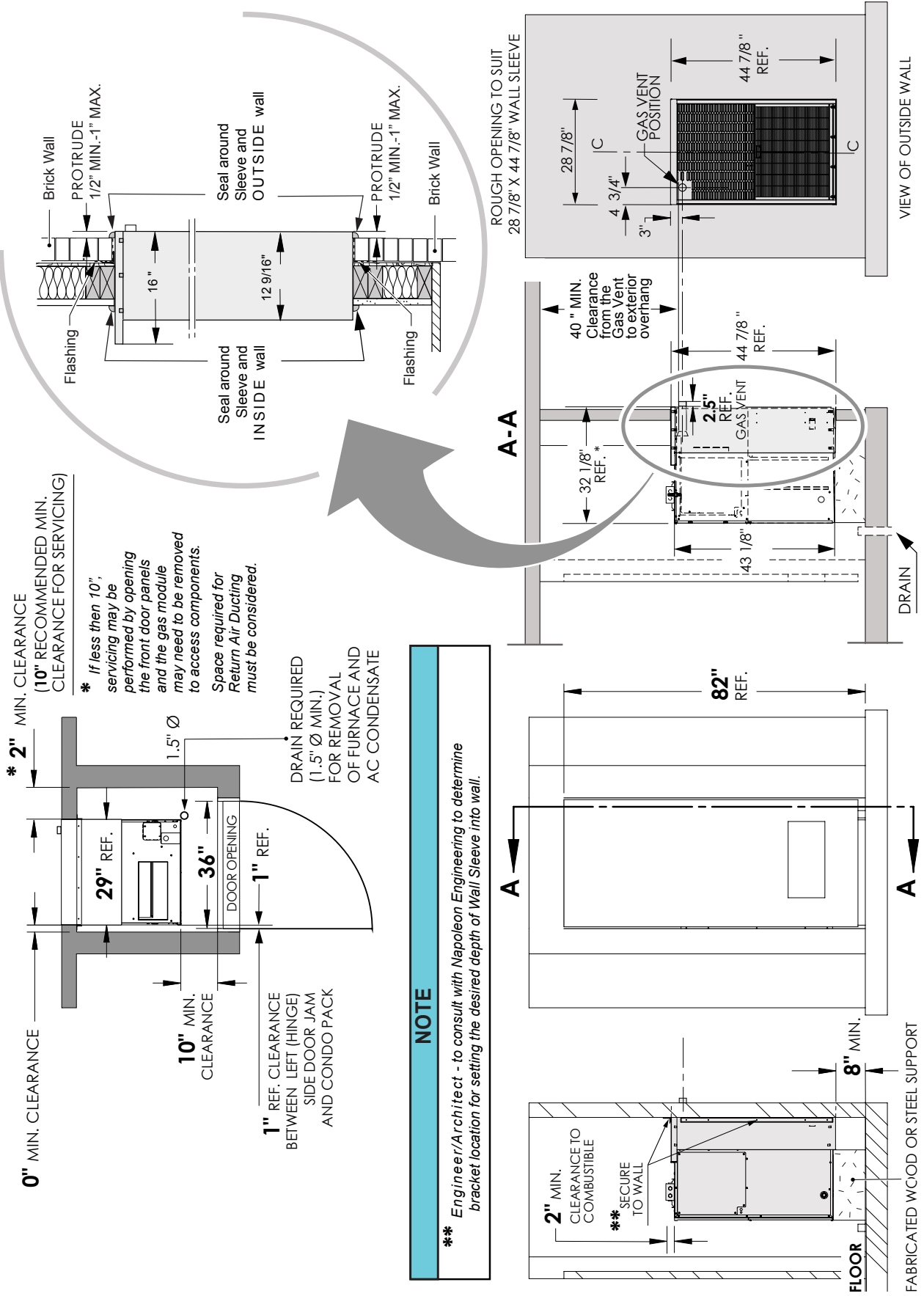

CONDO PACK SHOWN IN WALL SLEEVE

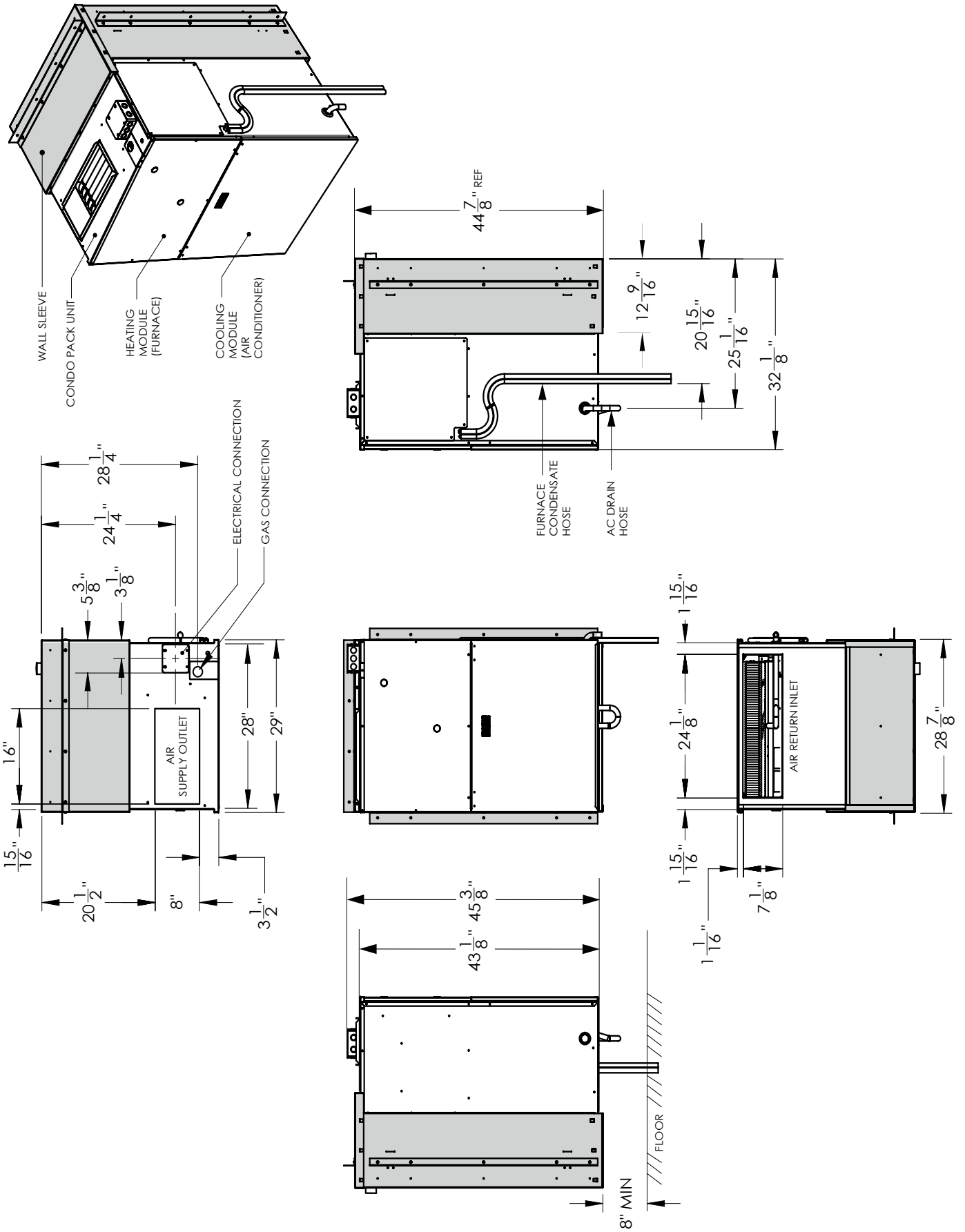



WOLF STEEL LTD.

24 Napoleon Road, Barrie, Ontario, Canada L4M 0G8

PHONE: 866-820-8686 • FAX: 705-725-1150

Website: www.napoleonheatingandcooling.com

General: hvac@napoleonproducts.com

Technical inquiries: hvacsupport@napoleonproducts.com



Intertek
9700539

