

This Owner's Manual is provided and hosted by [Appliance Factory Parts](#).



# GENERAL 2414-FC Owner's Manual

[Shop genuine replacement parts for GENERAL 2414-FC](#)



[Find Your GENERAL Air Cleaner Parts - Select From 69 Models](#)

----- Manual continues below -----



# Second Wind Air Purifier 2414-PREMIUM Installation Manual

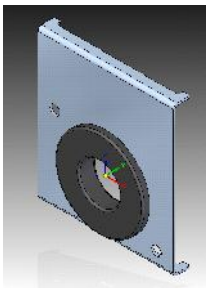
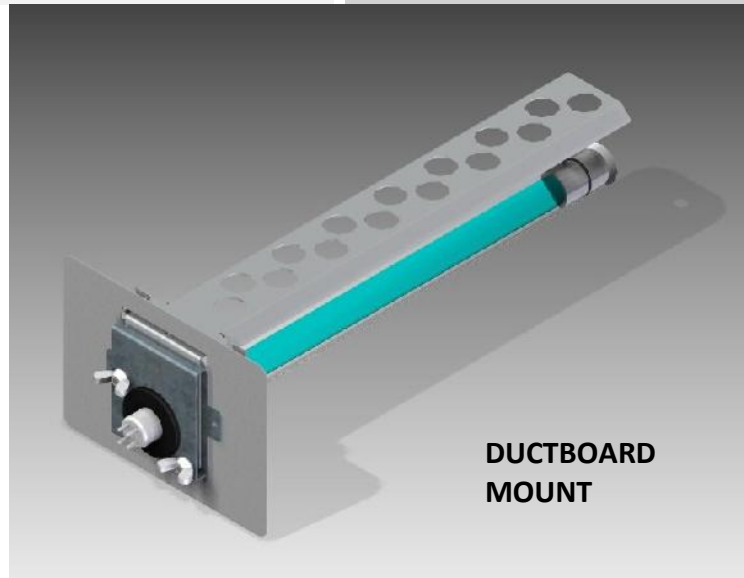
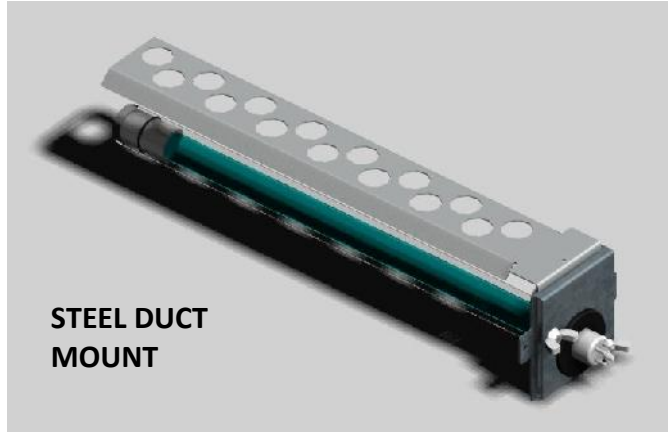
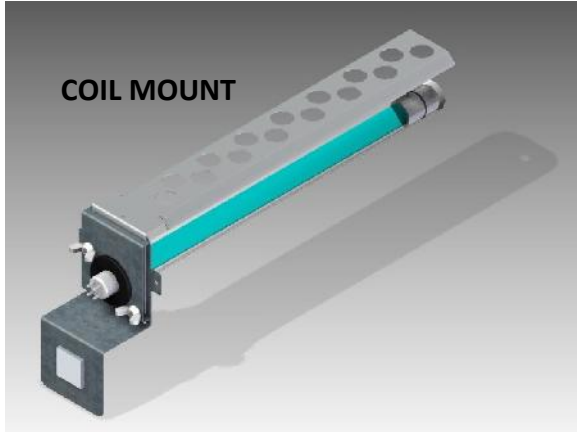

CLAMP PLATE

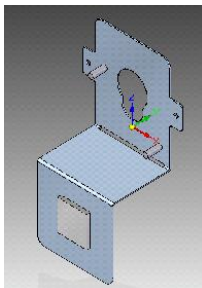

Z-BRACKET

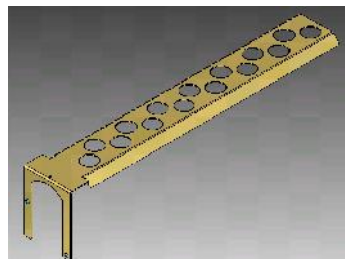

PCO BRACKET

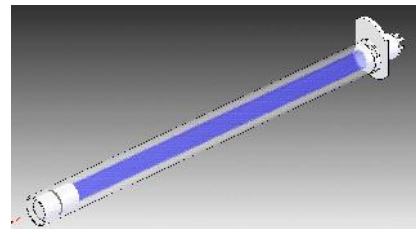

SHIELDED LAMP ASSEMBLY

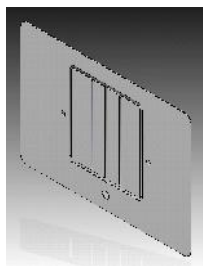

DUCTBOARD  
PLATE

**ALSO INCLUDED**

- BALLAST
- TECH MANUAL

• **HARDWARE KIT**

- INSTALLATION GLOVES

• **SERVICE LABEL**

**WARNING: FAILURE TO FOLLOW THESE RULES MAY RESULT IN SERIOUS PERSONAL INJURY**

- 1 Read these instructions carefully; failure to follow them could damage the product and cause a hazardous situation.
- 2 Installer must be a trained, experienced service technician
- 3 UV Light Hazard. Harmful to bare skin and eyes. UV radiation can cause temporary or permanent loss of vision. Never look at lamps while illuminated. To reduce the risk of exposure to UV radiation, take UV-radiation protective measures for personnel during servicing.
- 4 This fixture is designed for use with germicidal UV-C lamps and must be installed in compliance with competent technical directions so that user's eyes and bare skin will not be subjected to injurious rays.
- 5 UV Light Hazard. To prevent exposure to ultraviolet light, be sure the ultraviolet air treatment system is disconnected before servicing any part of the HVAC system or removing any access panel or the equivalent.
- 6 There shall not be any openings in the duct that would emit light.
- 7 There shall not be any duct supply or return air openings or any other openings that are in direct line-of-sight of the UV bulb.
- 8 Check damaged parts: Before further use of the unit, any damaged part should be carefully checked to ensure that the unit will operate properly. Any part that is damaged should be properly repaired or replaced.

**CAUTION: Disconnect power before starting installation or maintenance.**

- 1 Personal Injury Hazard. Power supply can cause electrical shock. Disconnect power supply before servicing or beginning installation.
- 2 Risk of exposure to excessive ultraviolet (UV) radiation—Do not operate without complete lamp enclosure in place or if sight lens is damaged.
- 3 Equipment Damage Hazard. Ultraviolet light can cause color shift or surface degradation and sometimes structural degradation of non-metallic components. Select mounting location that prevents exposure to plastic flexible duct components, polyurethane foam insulation material, rubber hoses, wire insulations, etc. If mounting options are limited, items above should be protected with ultraviolet resistant materials such as aluminum foil, aluminum duct tape, or metallic shields.
- 4 Electrical shock hazard from 24 volt or 120/277 VAC may cause serious injury or death.
- 5 Follow Proper Disposal Techniques for UV lamps (pg.3)
- 6 Wear protective gloves and safety glasses when handling lamp. To prevent injury, unplug lamp connector and allow to cool for 10 minutes before servicing.

**RECOMMENDED TOOLS**

- Electric Drill
- Screwdriver/Nut driver
- Tin Snips
- Eye Protection
- Ductboard Knife
- Permanent Marker
- Tape measure
- Aluminum tape and sealant
- Multimeter

**PRE-ASSEMBLY INSTRUCTIONS—OVER THE COIL INSTALLATION**

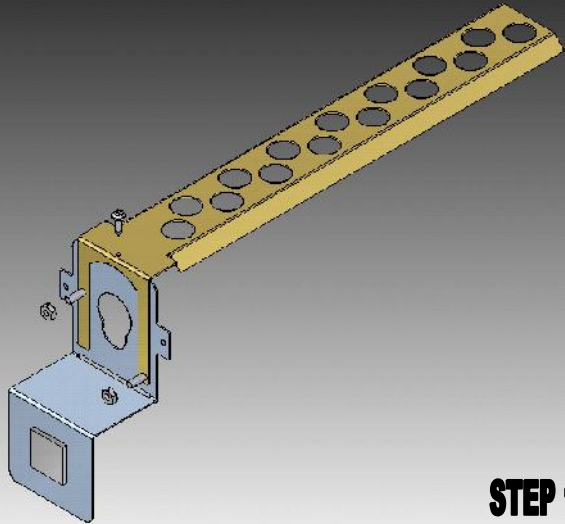

**STEP 1**

**STEP 1**

- INSTALL PCO BRACKET ON Z-BRACKET PEM STUDS
- SECURE WITH HEX NUTS
- INSTALL SELF TAP SCREW IN TOP OF PCO BRACKET

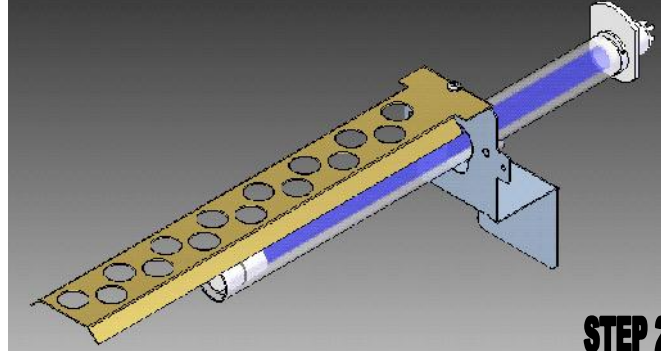

**STEP 2**

**STEP 2**

- PUT RUBBER GLOVES ON HANDS
- REMOVE LAMP ASSEMBLY FROM PACKAGING
- CAREFULLY INSERT LAMP ASSEMBLY INTO Z-BRACKET 'FIGURE 8' CUT-OUT IN ORIENTATION SHOWN

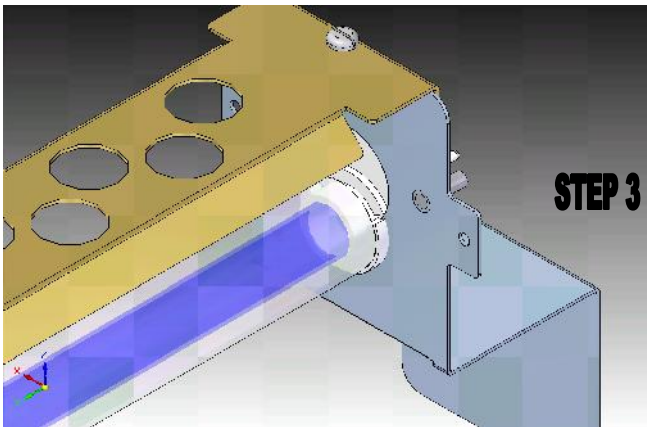

**STEP 3**

**STEP 3**

- LOWER LAMP ASSEMBLY INTO BOTTOM OF 'FIGURE-8' CUTOUT TO SECURE

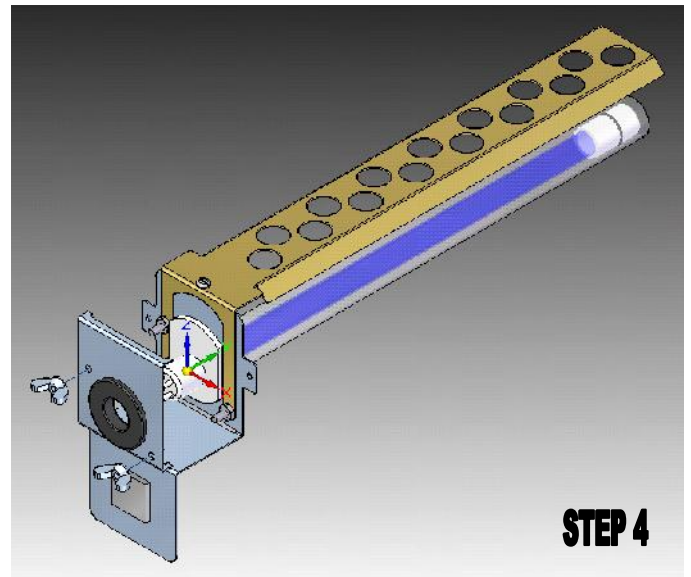

**STEP 4**

**STEP 4**

- INSTALL CLAMP PLATE ON Z-BRACKET PEM STUDS
- THREAD PLASTIC WING NUTS ONTO PEM STUDS AND TIGHTEN BY HAND

**ADDITIONAL INSTRUCTIONS FOR SHEET METAL DUCT MOUNT & DUCTBOARD MOUNTING**

**DUCT CUTOUT**  
 $\varnothing$  2.00 OR  
 2.5" W X 2.5" H

**SEAL CUTOUTS**  
 W/ ALUMINUM  
 TAPE AFTER  
 INSTALLATION

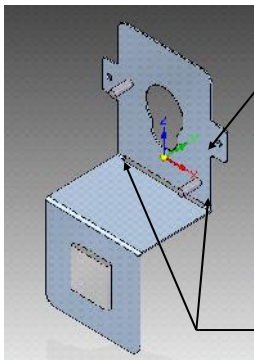

ANCHOR MOUNTS  
 TO DUCT

CUT TABS  
 ON EDGE

E-Z BENDS TO CUSTOM  
 FORM FIT DUCTBOARD  
 INSTALLATIONS

LED LENS  
 INSTALLATION  
 HOLE

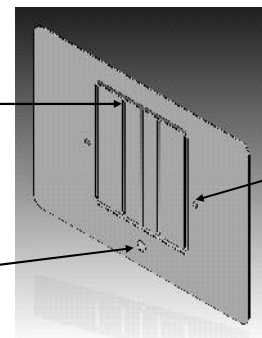

**DUCTBOARD  
 CUTOUT**  
 2.5" W X 3.5" H

INSTALL  
 Z-BRACKET TO  
 PLATE WITH  
 SHEET METAL  
 SCREWS AT  
 THESE HOLES

## INSTALLATION:

Prime location for installation of this device is on the supply side duct just above the condensing coil (aka A-coil, slab coil, etc), but it can be installed on the return side if necessary. See Figures below.

1. Follow Pre-Assembly instructions on page 3
2. Disconnect air handler from supply power.
3. Products shall be mounted only on to metal components of air ducts or air handlers (AHU). If installing on fiberglass ductboard, the supplied adaptor plate must be used.
4. Drilling is not required for mounting over or around coil exterior. Before installation under A-coil make sure before drilling into equipment that there is nothing in the way that would be damaged. Z –bracket to be clipped at EZ bend to enable mount of lamp under A-coil
5. The lamp should be installed a minimum of 2-3 inches, maximum 36 inches away from the coil or pan surface.
6. When looking for a mounting location try to install the unit away from non UV resistant plastics, rubber, and other non metallic materials. Shield these components using sheet metal, aluminum tape, or metal conduit.
7. The PCO Bracket should be positioned so that the air flows past the UVC light first then through the PCO Bracket.
8. Ballast is included with a magnet for installation, but ballast case **MUST BE POSITIVELY GROUNDED** for proper safety requirements per manufacturer’s schematic on ballast. Install ballast and assemble 4 pin connector to lamp base.
9. Use Ø1/4” drill to cut a hole in sheetmetal near install location. Insert supplied LED lens to provide visibility of lamp operation. DUCTBOARD INSTALLATION - LED lens hole is included in ductboard plate, therefore drilling is not required for this step
10. Connect ballast to 24V power supply per ballast manufacturer’s schematic (on ballast case).
11. Replace protective covers previously removed and re-connect to supply power.

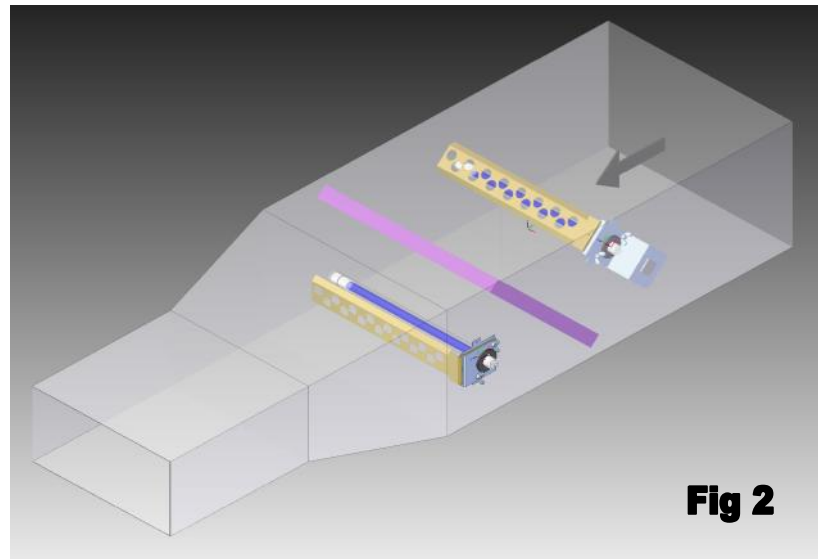
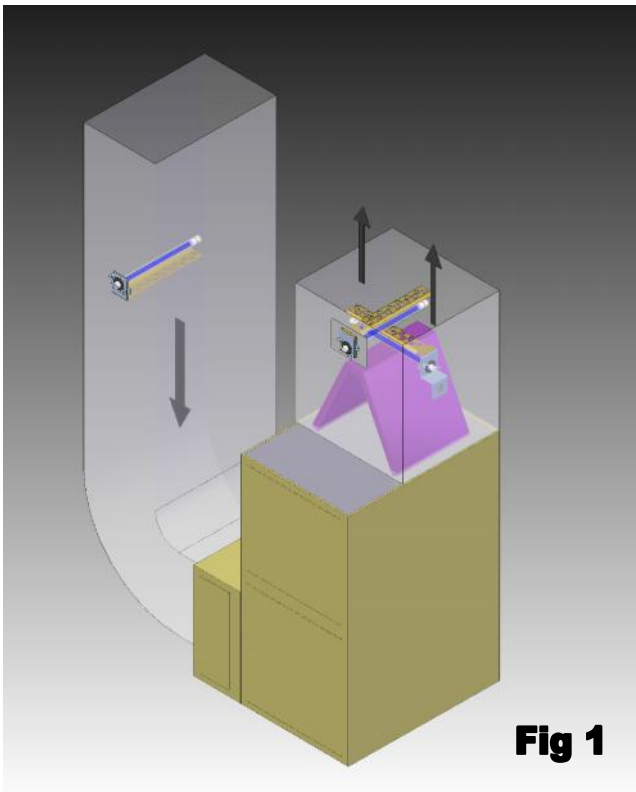

**AIRFLOW DEPICTED BY ARROWS**

**TYPICAL INSTALL LOCATIONS**

**LAMP REPLACEMENT**

The Second Wind Ultraviolet Germicidal 24 Volt Lamp is designed for 14000-16,000 hours of continuous operation. After 16000 hours (approx 22 months) intensity of the lamp inside the duct diminishes and should be replaced. Even if lamp is still illuminated, replacement of the lamp is recommended by a qualified HVAC Service Technician.

1. Disconnect electrical service and turn unit off.
2. Remove Z-bracket from mount location and disconnect lamp connector from lamp base **OR** remove lamp connector from lamp base on external mount units.
3. Remove plastic wing nuts from clamp plate with grommet and remove old lamp **CAUTION: old lamp may still be hot!**
4. Replace the old lamp with the new lamp, making sure the new lamp is clean and properly seats in bottom of figure-8 cutout. If the new lamp is dirty or has fingerprints on it remove with an alcohol wipe.
6. Place clamp plate lamp bracket over new lamp base and secure with plastic wing nuts.
7. Attach lamp connector to the lamp base. Return Z-bracket assembly to original install location
8. Turn on electrical service and unit.
9. If lamp does not immediately illuminate, turn off electrical service and unit. Reverse pin contacts in connector by rotating connector 180 degrees

REPLACEMENT	PART#	CHANGE CYCLE
LAMP	102-959	EVERY 2 YEARS
BALLAST	102-932	AS REQ'D

**LAMP DISPOSAL**

UV lamps contain mercury like other household lamps and must be disposed of properly. **State requirements and recycling opportunities vary, go to [www.lamprecycle.org](http://www.lamprecycle.org) for State Regulations & Contacts.** Please contact your county waste collection department for proper disposal details.

**USE GLOVES AND EYE PROTECTION**

If a lamp is broken, **do not use a vacuum cleaner to pick up the waste** . Instead, sweep up the waste into a plastic bag and seal. Contact your county waste collection department for proper disposal details.

## TROUBLESHOOTING

If the unit does not work, check the following:

**Electrical Supply/Wiring**—Verify that the electrical service is operating correctly.

**Ballast**—If lamp still is not illuminating check the wiring to the ballast. If the ballast is wired properly and the lamp still does not illuminate, replace the ballast. With a fully electronic ballast there is no resistance testing.

**Transformer**—If a transformer is employed to provide power to the unit (not provided by Second Wind), it should be tested in accordance with instructions provided with unit when installed.

**Lamp**—Verify that the lamp is not broken and is properly seated in the lamp connector. To check this, follow steps in the 'Lamp Replacement' section with one exception: you should not remove and replace the lamp. If the lamp is broken read the 'Lamp Disposal' section of this manual.



**ATTENTION INSTALLERS AND HOMEOWNERS**  
**YOUR SECOND WIND PRODUCT MUST BE REGISTERED WITH SECOND WIND TO QUALIFY FOR WARRANTY CLAIMS - SEE CONTAINER OR CALL 1-800-387-4565 FOR ASSISTANCE**

**SECOND WIND AIR PURIFIER WARRANTY**

The Second Wind 2414-PREMIUM that is attached to your Heating, Ventilation and Air Conditioning System (HVAC) has the following warranty, applicable in U.S.A. and Canada

**ONE (1) YEAR WARRANTY COVERAGE LAMPS**

The lamps are warranted by Second Wind for a period of one (1) year from the date of the original installation, when installed and operated in accordance with Second Wind recommendations. If during this period a lamp fails, Second Wind will provide a free replacement.

**FIVE (5) YEAR LIMITED WARRANTY**

Second Wind Air Purifier warrants this product, excluding lamps and ballast to be free from defects in the workmanship or materials, under normal use and service, for a period of five (5) years from the date of original installation, when installed and operated in accordance with Second Wind recommendations. If during this period a covered component fails, Second Wind will repair or replace the part.

**LIFETIME BALLAST WARRANTY**

The ballast is warranted by Second Wind Air Purifier for the lifetime of this product, when installed and operated in accordance with Second Wind Air Purifier recommendations. If during its lifecycle, the ballast fails, Second Wind will provide a free replacement after failure is returned for evaluation.

**SHIPPING, REPAIRS AND ALL OTHER COSTS OF WARRANTY SERVICE**

End user must pay shipping charges and all other costs of warranty service. Second Wind will not pay labor involved in diagnostic calls or in removing, servicing, or replacing parts. All repairs of covered components must be made with authorized service parts. Labor charges resulting from diagnostic calls or service are not covered by this warranty.

**CARE OF EQUIPMENT**

Your new Second Wind Purifier must be properly installed, operated and maintained in accordance with the unit installation, operation, and maintenance instructions provided with each unit. Failure to provide maintenance per Second Wind instructions will void warranty.

**WARRANTY LIMITATIONS**

This warranty will be voided if the covered equipment (only Second Wind replacement parts or units are warranted) is removed from the original installation site. This warranty does not cover damage or defect resulting from:

- 1 Accident, or neglect or unreasonable use or operation of the equipment, including operation of electrical equipment at voltages other than the range specified on the unit name plate.
- 2 Modification, change or alteration of the equipment, except as directed by Second Wind The furnishings of replacement parts under terms of this warranty will apply to the original warranty period and will not extend the warranty.

Second Wind makes no express warranties other than the warranty specified above. All implied warranties, including the implied warranty of merchantability and fitness for a particular purpose, are limited to the duration of the warranty specified above. Liability for incidental and consequential damages is excluded and is not covered by this warranty. Some States do not allow limitations on the duration of an implied warranty or the exclusion or limitation of incidental or consequential damages, so the limitations or exclusions may not apply to you.

This warranty gives you specific legal rights, and you may also have other rights which vary from state to state. Second Wind shall not be liable for any default or delay in performance under this warranty caused by any contingency beyond their control.

**WARRANTY PROCEDURE**

All Second Wind Air Purification systems that are attached to your Heating, Ventilation and Air Conditioning System (HVAC) have a limited unit warranty. To receive warranty consideration, the following must be provided.

- 1 Be prepared to furnish the following information:
  - a- Complete model number and serial number
  - b- Proof of installation date if warranty claim is made by other than a qualified service dealer who maintains records of your installation date and service history.
  - c- An accurate description of the problem.
  - d- Date of failure.
- 2 Call the installing dealer that you purchased your Second Wind device from.
- 3 If the installing dealer is unable to provide warranty parts, contact:

Second Wind Air Purifiers Inc,  
255 Great Arrow Avenue, Unit 217  
Buffalo, NY 14207

Phone: 1-800-387-4565

Fax: 716-875-5751

Email: [service@secondwindairpurifier.com](mailto:service@secondwindairpurifier.com)