

This Owner's Manual is provided and hosted by [Appliance Factory Parts](#).



George Foreman GHFD6800B Owner's Manual

[Shop genuine replacement parts for George Foreman
GHFD6800B](#)



[Find Your George Foreman Other Parts - Select From 6 Models](#)

----- Manual continues below -----

GEORGE FOREMAN®



TWIST 'N CRISP PREMIUM AIR FRYER 3 LITER CAPACITY

USE AND CARE MANUAL

GHFD6810B

GHFD6800B

GHFD6820G

GHFD6830G

GHFD6840G



www.georgeforemancooking.com

IMPORTANT SAFEGUARDS.

When using electrical appliances, basic safety precautions should always be followed to reduce the risk of fire, electric shock, and/or injury, including the following:

- Read all instructions before using.
- Do not touch hot surfaces. Use handles, knobs, or pot holders.
- To protect against electrical shock do not immerse the appliance, cord, or plugs in water or other liquids. Do not rinse or let any liquids enter the appliance. Removable parts can be immersed in water.
- Close supervision is necessary when any appliance is used by or near children.
- Only operate the appliance on a flat, even and stable surface.
- Always operate the air fryer with the removable non-stick bowl in place.
- Do not cover the air inlet and the air outlet openings while the appliance is operating.
- Do not fill the pan with oil as this may cause a fire hazard.
- Unplug from outlet and allow to cool before cleaning or when not in use.
- Allow to cool before putting on or taking off parts.
- Do not operate any appliance with a damaged cord or plug, or after the appliance malfunctions or has been damaged in any manner. Contact the consumer support number listed in this manual.
- The use of accessory attachments not recommended by the appliance manufacturer may cause injuries.
- Do not use outdoors.
- Do not plug in the appliance or operate the control panel with wet hands.
- Do not let cord hang over edge of the table or counter, or touch hot surfaces.
- Do not place on or near a hot gas or electric burner, or in a heated oven.
- Extreme caution must be used when moving an appliance containing hot oil or other hot liquids.
- To disconnect, cancel any running program by pressing the power button (⏻) and wait for the fan to turn off. Then unplug from wall outlet.
- Do not use appliance for other than intended use.
- Do not operate appliance unattended.
- Use extreme caution when removing accessories holding hot food, or disposing of hot grease.
- Do not clean with metal scouring pads. Pieces can break off the pad and touch electrical parts, creating risk of electric shock.
- Oversize foods and metal utensils must not be inserted into the machine, as they may create a fire or risk of electric shock.
- A fire may occur if the appliance is covered or touching flammable materials including curtains, draperies, walls and the like, when in operation. Do not store any item on top of or touching the unit when in operation. Leave at least 4 inches (10 cm) free space on the back and sides of the appliance.
- Do not store any material, other than the manufacturer's recommended accessories, in this appliance when not in use.
- Do not place any of the following materials in the appliance: paper, cardboard, plastic, and the like.
- Do not cover any part of this appliance with metal foil. This will cause overheating of the appliance.
- During hot air frying, hot steam is released through the air outlet

openings. Keep hands and face at a safe distance from the steam and from the air outlet openings. Also, be careful of hot steam and air when you remove the accessories and food from the appliance.

- If you see dark smoke coming out of the appliance, immediately cancel the program by pressing the power button (⏻) and unplug the appliance. Wait for the smoke emissions to stop before you remove the accessories and food from the appliance.
- Do not leave the appliance unattended when in operation. Food ignition may occur. If this happens, immediately cancel the program by pressing the power button (⏻) and unplug the unit but DO NOT open it. To reduce the risk of fire, keep oven interior completely clean and free

of food residues, oil, grease and any other combustible materials.

- Condensation may form at the bottom of the appliance during the cooking process. Only operate on surfaces that are water resistant.”
- This appliance is not intended for use by persons (including children) with reduced physical, sensory or mental capabilities, or lack of experience and knowledge, unless they have been given supervision or instruction concerning use of the appliance by a person responsible for their safety.
- Children should be supervised to ensure that they do not play with the appliance.
- The appliance is not intended to be operated by means of an external timer or separate remote-control system.

SAVE THESE INSTRUCTIONS.

This product is for household use only.

POLARIZED PLUG

This appliance has a polarized plug (one blade is wider than the other). To reduce the risk of electric shock, this plug is intended to fit into a polarized outlet only one way. If the plug does not fit fully into the outlet, reverse the plug. If it still does not fit, contact a qualified electrician. Do not attempt to modify the plug in any way.

TAMPER-RESISTANT SCREW

Warning: This appliance is equipped with a tamper-resistant screw to prevent removal of the outer cover. To reduce the risk of fire or electric shock, do not attempt to remove the outer cover. There are no user-serviceable parts inside. Repair should be done only by authorized service personnel.

ELECTRICAL CORD

- 1) A short power-supply cord is provided to reduce the risks resulting from becoming entangled in or tripping over a longer cord.
- 2) Extension cords are available and may be used if care is exercised in their use.
- 3) If an extension cord is used:
 - a) The marked electrical rating of the extension cord should be at least as great as the electrical rating of the appliance;
 - b) If the appliance is of the grounded type, the extension cord should be a grounding-type 3-wire cord; and
 - c) The cord should be arranged so that it will not drape over the counter top or tabletop where it can be pulled on by children or tripped over.

Note: If the power cord is damaged, please contact the warranty department listed in these instructions.

GETTING TO KNOW YOUR AIR FRYER

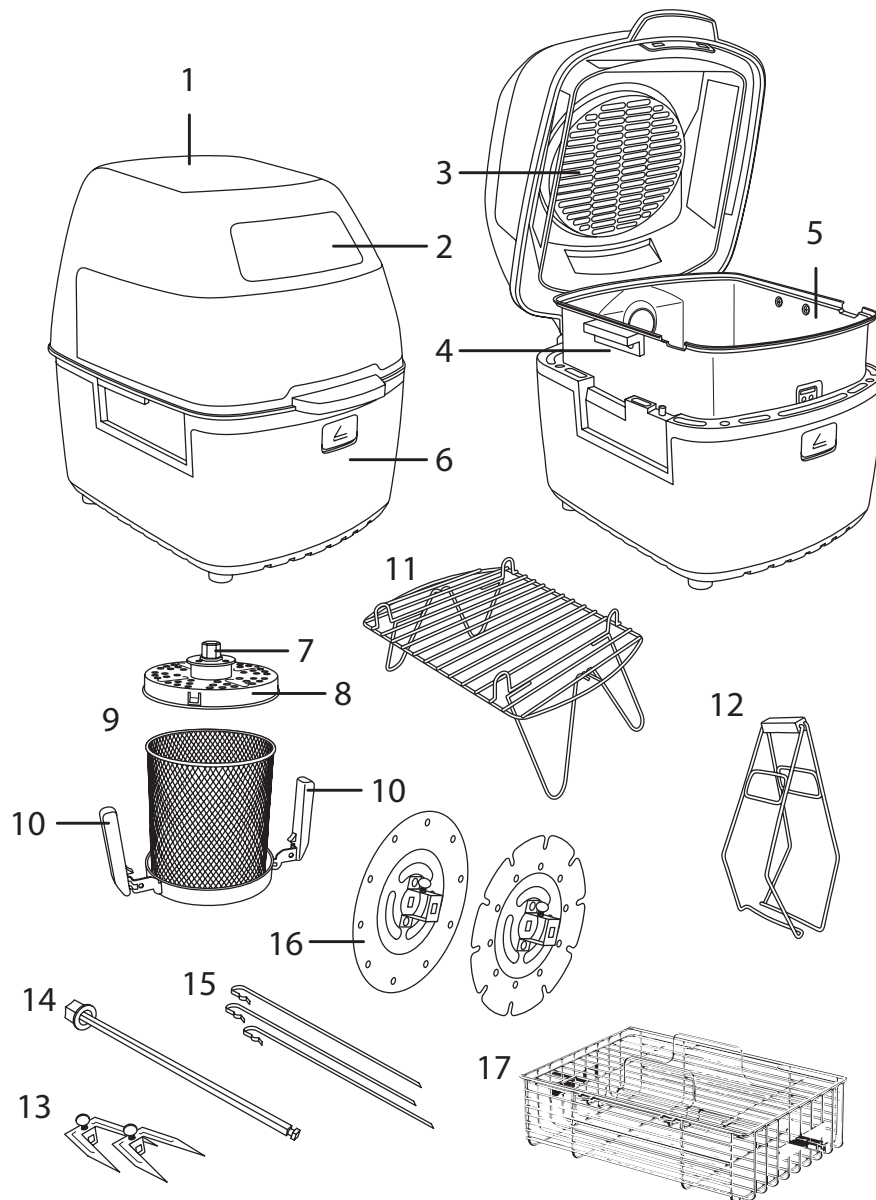

- | | |
|--|---|
| 1. Lid | 10. Cool touch Drum handles |
| 2. Display/touch controls | †11. Baking rack (Part# GHFD68-04) |
| 3. Heating element | †12. Tongs (Part# GHFD68-05) |
| 4. Bowl handles | †13. Rotisserie forks (Part# GHFD68-06) |
| 5. Removable non-stick bowl
(Part# GHFD68-01) | †14. Spindle (Part# GHFD68-07) |
| 6. Lid release button | †15. Skewers (x10) ((1pc) Part# GHFD68-08) |
| 7. Drive shaft | †16. Kebab holder plates (Part# GHFD68-09) |
| † 8. Drum lid (Part# GHFD68-02) | †17. Sandwich basket (Part# GHFD68-10) |
| † 9. Drum (Part# GHFD68-03) | Note: † indicates consumer replaceable/
removable parts |

HOW TO USE

This product is for household use only.

GETTING STARTED

- Remove all packing material, any stickers, and the plastic band around the power plug.
- Remove and save literature.
- Please visit www.prodprotect.com/georgeforeman to register your warranty.

BEFORE USING FOR THE FIRST TIME





- Hand wash the removable parts. Rinse then dry thoroughly.
- The new heating element may smoke a little during the first use as it burns off residual oil from the manufacturing process. This may cause small amounts of smoke or odor but it's normal and nothing to worry about. Ensure the room is well ventilated.

DISPLAY

During use, the display alternates between showing the current temperature and the default program time for the currently selected program. If a program is already running, the display will show the remaining program run time. When the temperature is displayed, the temperature button (🌡️) will light up. When the time is displayed, the time button (⌚) will light up.

PROGRAM GUIDE

You can change the default program temperature and program run time.

Program	Default Settings		Adjustable Range	
	Temp. °F	Minutes	Temp. °F	Minutes
Air Fry 	425°F	30	300 - 425°F	1 - 60
Roast/Bake 	350°F	30	200 - 425°F	1 - 60
Grill 	375°F	15	200 - 425°F	1 - 60
Rotisserie 	375°F	30	250 - 425°F	1 - 60

- To select a program, press the relevant button shown above.
- To change the temperature, first tap the temperature button (🌡️) then use the up (▲) and down (▼) arrows to select the desired temperature.
- To change the program run time, first tap the time button (⌚) then use the up (▲) and down (▼) arrows to select the desired time.
- If required, you can change the time and temperature settings using the same method while the program is running.

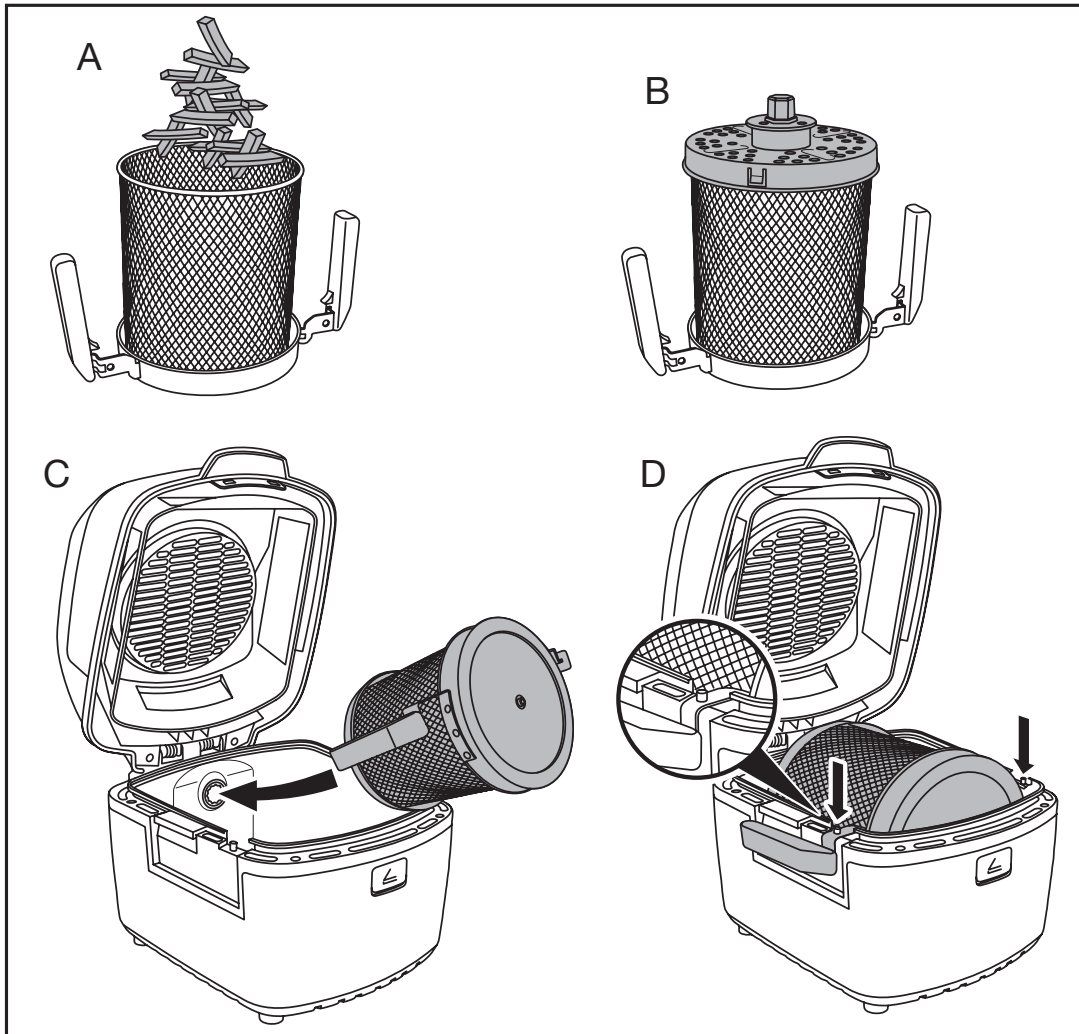

AIR FRYING

1. Unplug your air fryer.
2. Place the items to be fried into the drum. Don't overfill the drum. Allow enough space for air to circulate and the ingredients to move freely (fig A).
3. Fit the lid securely onto the drum (fig. B).
4. Insert the drive shaft into the opening in the bowl (fig. C).
5. Lower the drum down until the two holes in the handles fit over the two pins in the body of the fryer (fig. D). The lid won't close unless the pins pass through the holes in the handle.
6. Plug in your air fryer. The unit will beep and the display will light up briefly.
7. Tap the power button (⏻).
8. The display will light up showing the available programs.
9. Tap the air fry button (🍷) to select the air fry program.
10. The display will alternate between showing the default air fry

temperature and the program run time (see DISPLAY). You can change either of these settings (see PROGRAM GUIDE).

11. Change the settings as desired or accept the defaults. Tap the power button (⏻) to start the program.
12. Once the program has finished, the display will go out (except the power button) and the fan will operate for 20 seconds. After 20 seconds, your air fryer will beep 5 times and then switch off.

REMOVING THE DRUM

1. Open the lid. Beware of any escaping steam and hot air.
2. Use the two cool touch handles to remove the drum. We recommend using oven gloves because the drum and surrounding areas will be HOT.
3. Press the drum away from you (towards the rear of the unit) then lift the end of the drum that is nearest to you slightly upwards until it clears the rim of the bowl.
4. Lift the drum clear of the bowl and place it down onto a heat resistant surface.
5. Using oven gloves, carefully remove the drum lid by pressing the triangular release tab then pulling the black cap straight away from the drum. (fig. E) Tip out the contents.

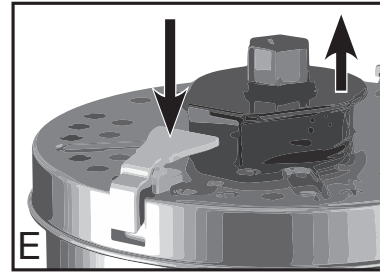

COLLAPSIBLE BAKING RACK

Before use, unfold and secure the legs of the rack as shown (fig. F). The supplied rack can be placed in the high position (fig. G) moving the food nearer to the heating element, or the low position (fig. H) moving the food further from the heating element. The legs of the rack can be folded for storage.

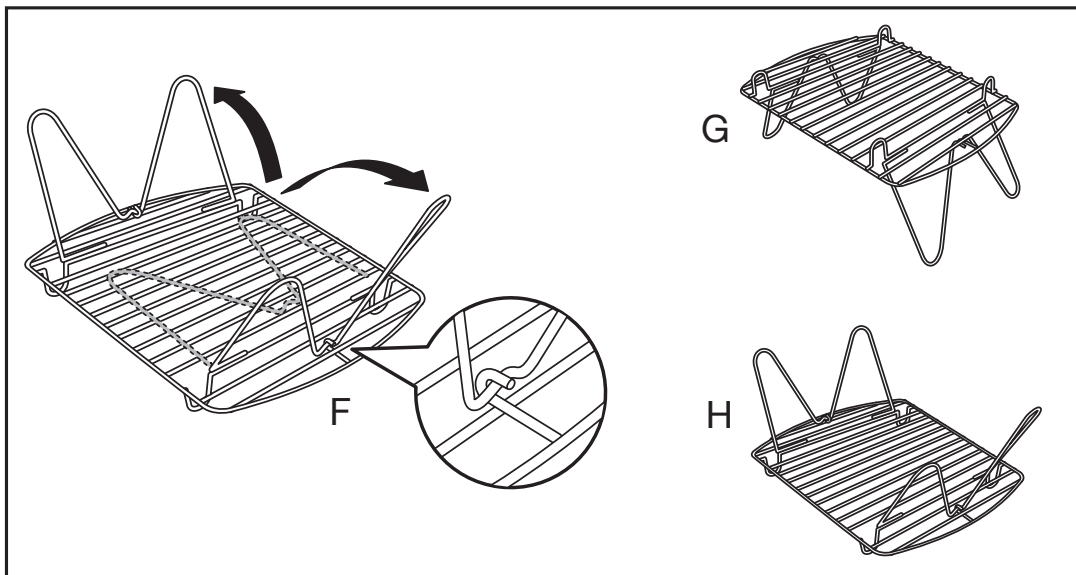

GRILLING

The grilling function is perfect for grilling, crisping or browning foods. Use as you would a conventional grill by bringing the food close to the heat using the rack.

1. Unplug your air fryer.
2. Place the rack in the bowl. Use it in the high position.
3. Plug in your air fryer. The unit will beep and the display will light up briefly.
4. Tap the power button (⏻).
5. The display will light up showing the available programs.
6. Tap the grill button (🔥) to select the grill program.
7. The display will alternate between showing the default grill temperature and the program run time (see DISPLAY). You can change either of these settings (see PROGRAM GUIDE).
8. Change the settings as desired or accept the defaults.
9. Tap the power button (⏻) to start the program.
10. Once the program has finished, the display will go out (except the power button) and the fan will operate for 20 seconds. After 20 seconds, your air fryer will beep 5 times and then switch off.
11. Open the lid. Beware of any escaping steam and hot air.
12. You can use the tongs to carefully remove the rack. We recommend you wear oven gloves.
 - The program can be paused at any time by opening the lid. Close the lid to resume the program.
 - To stop the program, press the power button (⏻). The program will stop and the fan will continue to run for 20 seconds. Any program settings will be lost.

ROASTING/BAKING

1. Unplug your air fryer.
2. Place the rack in the bowl. Use it in the low position. Food can also be baked directly in the bowl (e.g. cakes).
3. The food can be placed directly onto the rack or into a suitably sized oven-proof container.
4. Plug in your air fryer. The unit will beep and the display will light up briefly.
5. Tap the power button (⏻).
6. The display will light up showing the available programs.
7. Tap the roast/bake button (🍲) to select the roast/bake program.

8. The display will alternate between showing the default roasting/baking temperature and the program run time (see DISPLAY). You can change either of these settings (see PROGRAM GUIDE).
9. Change the settings as desired or accept the defaults.
10. Tap the power button (⏻) to start the program.
11. Once the program has finished, the display will go out (except the power button) and the fan will operate for 20 seconds. After 20 seconds, your air fryer will beep 5 times and then switch off.
12. Open the lid. Beware of any escaping steam and hot air.
13. You can use the tongs to carefully remove the rack. We recommend you wear oven gloves.
 - The program can be paused at any time by opening the lid. Close the lid to resume the program.
 - To stop the program, press the power button (⏻). The program will stop and the fan will continue to run for 20 seconds. Any program settings will be lost.

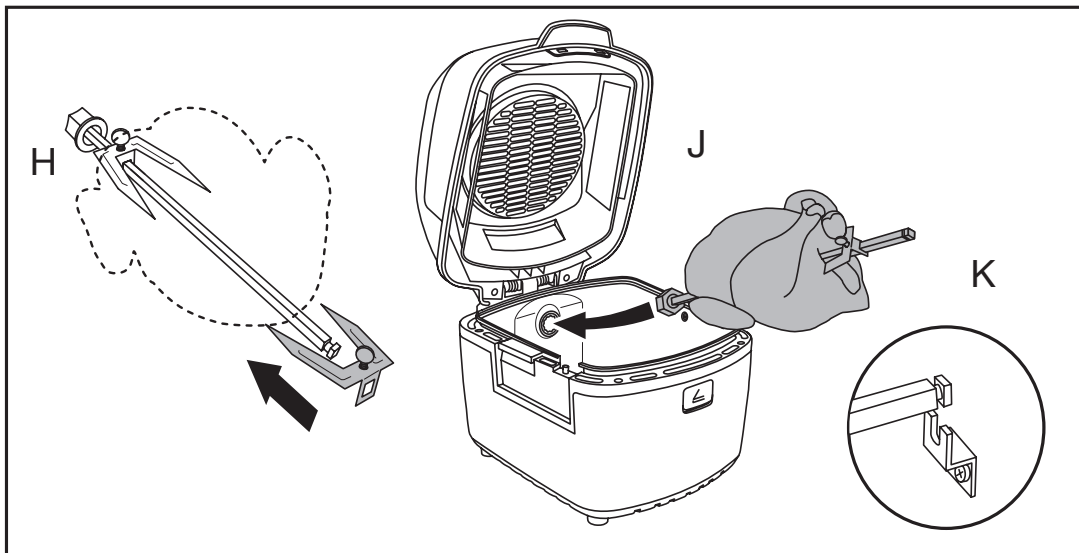

ROTISSERIE ATTACHMENT

The rotisserie attachment slowly turns the food under the heating element to give even cooking perfect for larger joints of meat and whole chickens.

1. Slide one of the rotisserie forks onto the spindle and tighten the screw. Skewer the meat onto the spindle then slide on the other fork as shown (fig. H). Tighten the screw on the fork to hold the meat.
2. Insert the drive shaft end of the spindle into the opening in the bowl (fig. J).
3. Lower the other end of the spindle onto the support bracket inside the bowl (fig. K).

4. Plug in your air fryer. The unit will beep and the display will light up briefly.
5. Tap the power button (⏻).
6. The display will light up showing the available programs.
7. Tap the rotisserie button (🍴) to select the rotisserie program.
8. The display will alternate between showing the default grill temperature and the program run time (see DISPLAY). You can change either of these settings (see PROGRAM GUIDE).
9. Change the settings as desired or accept the defaults.
10. Tap the power button (⏻) to start the program.
11. Once the program has finished, the display will go out (except the power button) and the fan will operate for 20 seconds. After 20 seconds, your air fryer will beep 5 times and then switch off.
12. Open the lid. Beware of any escaping steam and hot air.
13. You can use the tongs to carefully remove the food. We recommend you wear oven gloves.
 - The program can be paused at any time by opening the lid. Close the lid to resume the program.
 - To stop the program, press the power button (⏻). The program will stop and the fan will continue to run for 20 seconds. Any program settings will be lost.

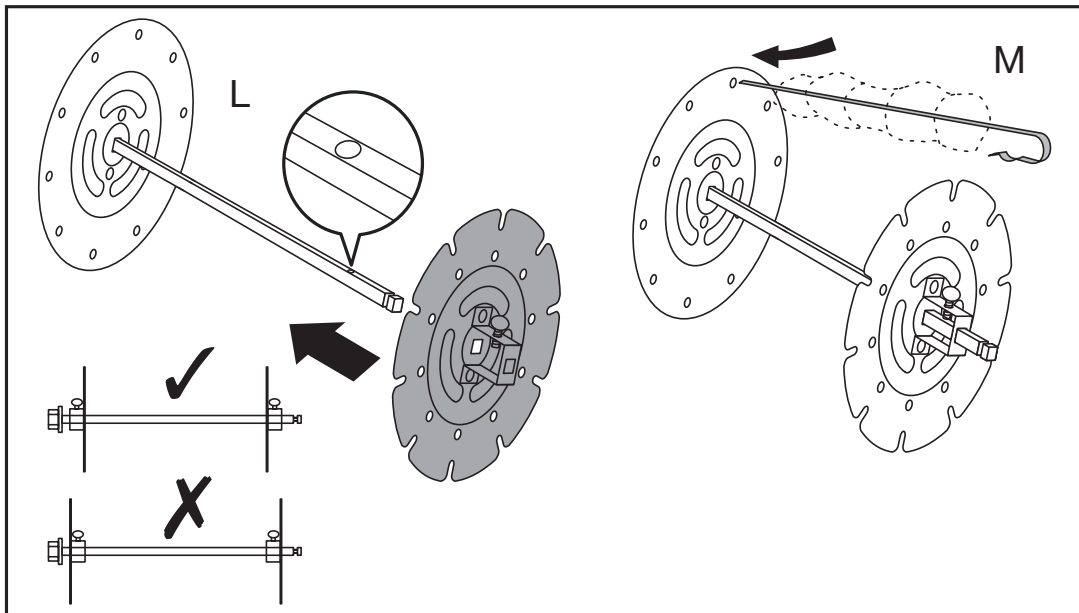

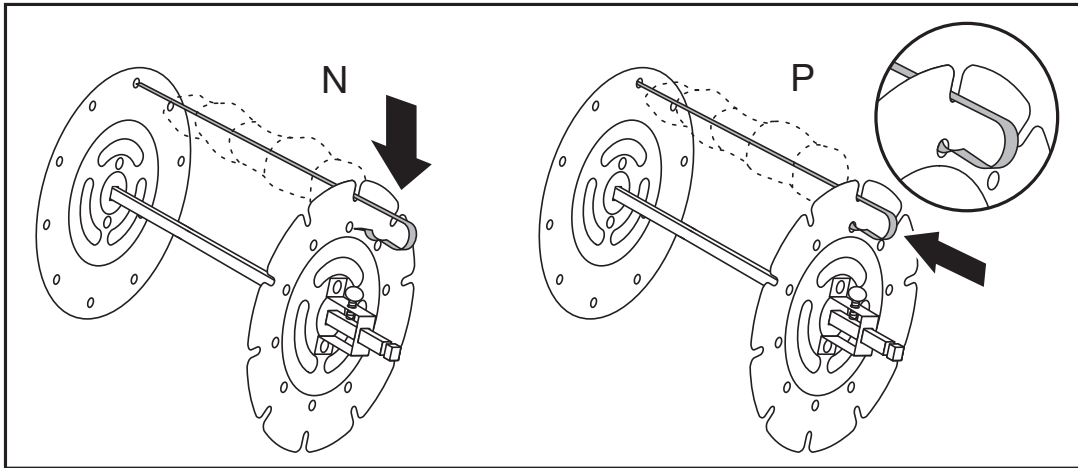

KEBAB ATTACHMENT

The kebab attachment is ideal for cooking kebabs etc. It gently rotates the food under the heating element for even cooking. The attachment can hold 10 skewers.

1. Slide the circular kebab holder plate onto the spindle. Orient this plate so that the part with the screw in it is at the same end as the black drive coupling. Slide the plate which has the slots in the rim onto the spindle with the screw facing outwards away from the other plate. There are two depressions on the face of the spindle. When securing the plates, make sure that the screws go into the depressions in the spindle before tightening (fig. L).
2. Place the food onto the skewers. Fit the end of the skewer into a hole in the plate (fig. M).
3. Fit the other end into the slot opposite the hole (fig. N).
4. Push the skewer forward until the curved end of the skewer clips into the hole below the slot (fig. P).
5. When all the skewers have been fitted, fit the kebab attachment into the bowl in the same way as the rotisserie attachment.
6. Operate your air fryer in the same way as when using the rotisserie attachment (See ROTISSERIE ATTACHMENT).

HINTS AND TIPS

- Don't put food that has a coating such as breadcrumbs into the drum or sandwich basket because the rotating/tumbling action will shake the coating from the food during cooking.
- Don't overfill the drum or sandwich basket because this can restrict hot air flow which can alter the cooking time and affect cooking quality.

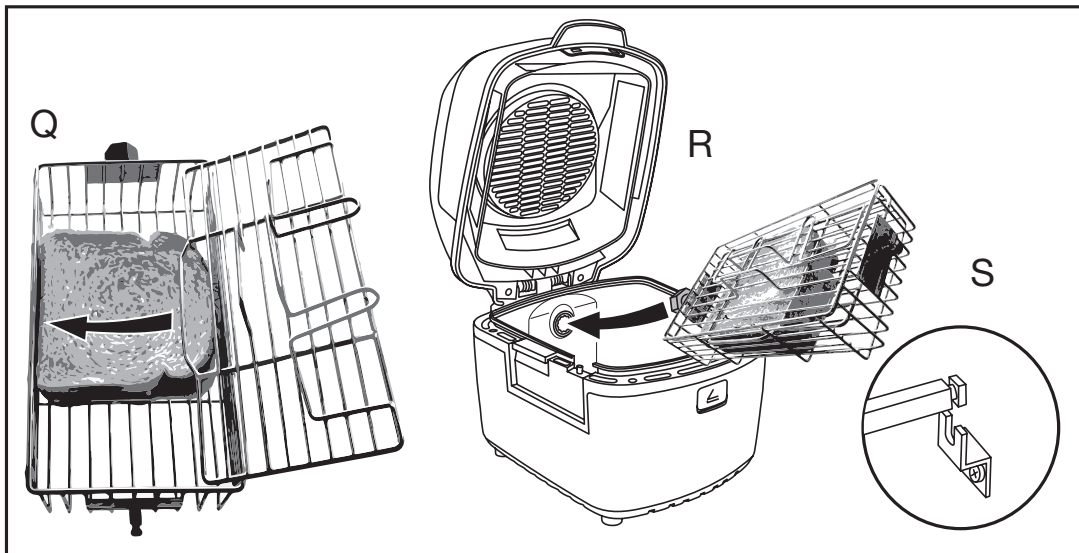

SANDWICH BASKET

The sandwich basket holds and rotates food that shouldn't be jostled, such as paninis or chicken wings.

1. Place the food in the basket. The sandwich basket lid can be adjusted to hold food as thin as 1/4" and thicker: up to 1 3/4". Put the larger tab of the lid into the basket between the basket rungs at the level that would best hold the food, as shown (fig. Q). Squeeze together the two handles on the lid to retract the two smaller tabs and lower the second side to the same level as the first side, locking the lid.
2. Insert the drive shaft end of the basket into the opening in the bowl (fig. R)
3. Lower the basket spindle end onto the support bracket inside the bowl (fig. S).
4. Operate your air fryer in the same way as when using the rotisserie attachment (See ROTISSERIE ATTACHMENT).

CARE AND MAINTENANCE

1. Unplug the appliance and let it cool down.
2. The bowl can be lifted out of the main body for cleaning.
3. Wipe the inner and outer surfaces of the appliance with a damp cloth.
4. Hand wash the removable parts, rinse, and dry.
5. When refitting the bowl, make sure that you press it all the way down into the body of the appliance.

You may wash these parts in a dishwasher: 5. Bowl, 11. Baking rack
12. Tongs, 13. Rotisserie forks, 14. Spindle, 15. Skewers, 16. Kebab holder plates 17. Sandwich basket.

If you use a dishwasher, the harsh environment inside the dishwasher will affect the surface finishes. The damage should be cosmetic only, and should not affect the operation of the appliance.

WARRANTY AND CUSTOMER SERVICE INFORMATION

For support or any questions regarding your appliance, call the appropriate 800 number listed within this section. Please DO NOT return the product to the place of purchase. Also, please DO NOT mail product back to manufacturer, nor bring it to a service center. You may also want to consult our Product Protection Center at www.prodprotect.com/georgeforeman.

Three-Year Limited Warranty

(Applies only in the United States and Canada)

What does my warranty cover?

- Your warranty covers any defect in material or workmanship provided; however, the liability of Spectrum Brands Inc. will not exceed the purchase price of product.

How long is the warranty period?

- Your warranty extends three years from the date of original purchase with proof of purchase.

What support does my warranty provide?

- Your warranty provides you with a reasonably similar replacement product that is either new or factory refurbished.

How do you get support?

- Save your receipt as proof of date of sale.
- Visit the online service website at www.prodprotect.com/georgeforeman, or call toll-free 1-800-947-3745, for general warranty service.
- If you need parts or accessories, please call 1-800-738-0245.

What does my warranty not cover?

- Damage from commercial use
- Damage from misuse, abuse or neglect
- Products that have been modified in any way
- Products used or serviced outside the country of purchase
- Glass parts and other accessory items that are packed with the unit
- Shipping and handling costs associated with the replacement of the unit
- Consequential or incidental damages (Please note, however, that some states do not allow the exclusion or limitation of consequential or incidental damages, so this limitation may not apply to you.)

How does state law affect my warranty?

- This warranty gives you specific legal rights. You may also have other rights that vary from state to state or province to province.

COOKING GUIDE

The following table gives approximate cooking times for common food items.

Food	Program	Accessory	Quantity	Approx. Time (min)
Frozen French fries	Air Fry	Drum	4 cups	35-45
Homemade potato chips	Air Fry	Drum	2 large potatoes	35-45
Chicken wings	Air Fry	Drum	1.5 lbs.	25-30
Chicken breast	Bake	Rack, high	1 lb. (2 breasts)	25-30
Fresh chicken strips	Bake	Rack, low	1 lb.	12-15
Frozen chicken nuggets	Bake	Rack, low	12-14 nuggets	12-14
Whole chicken	Rotisserie	Rotisserie	3.5-5 lb	50-60
Fresh burgers	Grill	Rack, high	1 lb.	10-14
Frozen burgers	Grill	Rack, high	2 burgers	15-17
Pork chops	Bake	Rack, high	1 lb.	12-16
Brats	Grill	Rack, high	5 brats	17-19
Bacon	Bake	Rack, low	4 strips	10-12
Sweet potato fries	Air Fry	Drum	2 med. potatoes	45-50
Frozen fish sticks	Bake	Rack, low	10-12 fish sticks	12-14
Salmon	Bake	Rack, high	2 (5 oz.) fillets	12-14
Roasted cauliflower	Air Fry	Drum	5-6 cups	10-15
Roasted Brussels sprouts	Air Fry	Drum	1 lb.	15-18
Roasted broccoli	Air Fry	Drum	5-6 cups	28-30
Mushrooms	Air Fry	Drum	16 oz.	12-16
Baked potato	Air Fry	Rack, low	4 large baking potatoes	50-60
Pizza	Bake	Rack, low		15-17
Kebab	Rotisserie	Skewers		10-12

Cook poultry, pork, burgers, etc., until the juices run clear. Cook fish, shrimp, etc., until the flesh is opaque throughout.

	Temp. °F	Notes
	425°F	
	425°F	Cut into 1/2" thick slices. Rinse twice in cold water, drain and dry with paper. Toss in 2 Tbsp. oil. Season with salt.
	425°F	
	400°F	Season and bake until internal temp reaches 165°F.
	400°F	Bake until internal temp reaches 165°F.
	400°F	Turn half way through cooking.
	375°F – 425°F	See recipe for further instructions.
	375°F	Form into 4 (1/4 lb.) patties. Turn half way through cooking.
	425°F	Turn half way through cooking.
	400°F	Turn half way through cooking
	375°F	Turn half way through cooking.
	425°F	
	400°F	Peeled. Cut into 1/4" thick slices. Toss in 2 Tbsp. olive oil and season.
	400°F	Turn half way through cooking.
	400°F	
	425°F	Cut into florets.
	425°F	Cut in half, remove outer leaves. Toss in 2 Tbsp. oil. Season with salt and pepper.
	425°F	Cut into florets.
	375°F	Toss in 1 Tbsp. olive oil. Season with salt and pepper.
	425°F	Rub with oil and season. Wrap in aluminum foil. Turn 1/2 way through.
	400°F	Small, frozen pizza. Remove all packaging.
	400°F	Cooking time depends on size of meat.

1230 W 120 V ~ 60 Hz

USA/Canada 1-800-947-3745
Accessories/Parts 1-800-738-0245
Register your product at www.prodprotect.com/georgeforeman

Made and Printed in China.

® Registered Trademark of Spectrum Brands, Inc.

© 2018 Spectrum Brands, Inc.
Middleton, WI 53562

T22-5004132-A
21799