

This Owner's Manual is provided and hosted by [Appliance Factory Parts](http://www.appliancefactoryparts.com).



MAJESTIC FI36M Owner's Manual

[Shop genuine replacement parts for MAJESTIC FI36M](#)

Log Set Assembly

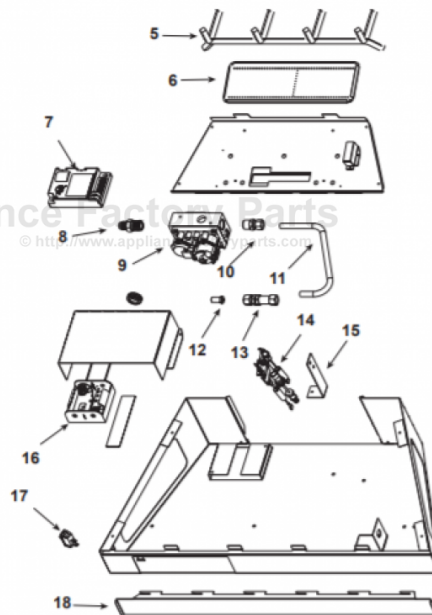

[Find Your MAJESTIC Fireplace Parts - Select From 585 Models](#)

----- Manual continues below -----

heatilator[®]

The first name in fireplaces

GAS-FIRED



Heatilator, a brand of Hearth & Home Technologies
7571 215th Street West, Lakeville, MN 55044
www.heatilator.com

INSTALLATION & OPERATING INSTRUCTIONS

IMPERIAL GAS LOGS

Fi36S Fi36SL Fi36M Fi36ML
Fi42S Fi42SL Fi42M Fi42ML

FOR RESIDENTIAL USE



WARNING: If the information in this manual is not followed exactly, a fire or explosion may result causing property damage, personal injury or loss of life.

- Do not store or use gasoline or other flammable vapors and liquids in the vicinity of this or any other appliance.
- What to do if you smell gas
 - Do not try to light any appliance.
 - Do not touch any electrical switch; do not use any phone in your building.
 - Immediately call your gas supplier from a neighbor's phone. Follow the gas supplier's instructions.
 - If you cannot reach your gas supplier, call the fire department.
- Installation and service must be performed by a qualified installer, service agency or the gas supplier.

WARNING!

Improper installation, adjustment, alteration, service or maintenance can cause injury or property damage. Refer to this manual. For assistance or additional information, consult a qualified installer, service agency or the gas supplier.

PLEASE RETAIN THIS MANUAL FOR FUTURE REFERENCE

Installation and service must be performed by a qualified installer, service agency or the gas supplier.

Table of Contents

A. Listings and Code Approvals.....3
 B. Description of the Imperial Gas Log Set.....3
 C. Important Information5
 D. Step-by-Step Installation6
 E. Operating Instructions for the "M" Series10
 F. Operating Instructions for the "S" Series11
 G. Glass Doors.....12
 H. Cleaning12
 I. Inspecting the Venting System.....12
 J. Important Safeguards.....13
 K. Servicing.....13
 L. Owner Registration/Warranty13
 M. Replacement Parts.....13
 N. Troubleshooting - "M" Series20
 O. Troubleshooting - "S" Series21
 P. Accessory Parts (For "M" Series Only).....22
 Warranty23

Note: An arrow (➡) found in the text signifies change in content.

WARNING!

This appliance is tested and listed for use only with the optional accessories listed in these instructions. Use of optional accessories not specifically tested for this appliance could void the warranty and/or result in a safety hazard.

Safety Precautions

1. Please read these installation instructions completely before beginning installation procedures. Failure to follow them could cause an appliance malfunction resulting in serious injury and/or property damage.
2. Always check your local building codes prior to installation. The installation must comply with all local, regional, state and national codes and regulations.
3. **NEVER** leave children unattended when there is a fire burning in the fireplace.
4. This Gas Log Set appliance is factory built to burn natural or propane gas. A gas conversion kit (to convert from natural gas to propane, or propane to natural gas) is available for the Imperial Series.
5. The flue damper must be open at all times when the appliance is in use.
6. While servicing this log set, always shut off any electricity or gas to the appliance. This will prevent possible electrical shock or burns. Also, make sure the fireplace is completely cooled before servicing.
7. Solid fuels cannot be burned in a fireplace where the decorative gas appliance is installed.
8. In order to install the Imperial Gas Log Set in the state of Massachusetts, the Commonwealth of Massachusetts requires the existing fireplace damper be removed.

The first name in fireplaces

A. Listings and Code Approvals

The Imperial Series Gas Log Set has been tested and listed in the U.S. in accordance with **ANSI Z21.60-1996** (Gas Log Set). In Canada the Imperial Series Gas Log Set has been tested and approved in accordance with **CGA 2.26-M96**. It has been listed by Underwriters Laboratories Inc. for installation and operation in the United States and Canada as described in these Installation and Operating Instructions. All components are UL, AGA, CGA or CSA safety certified.

Check with your local building code agency prior to installing this appliance to ensure compliance with local codes, including the need for permits and follow-up inspections. In the absence of local codes, comply with the **National Fuel Gas Code, ANSI Z223.1-Latest Edition** in the U.S.; in Canada, the **CAN/CGA B149 Installation Codes**. If any assistance is required during installation, please contact your dealer for more information or visit: www.hpba.org/staysafe.

HEATILATOR® is a registered trademark of Hearth & Home Technologies Inc.

WARNING!

This Heatilator appliance and its components are designed to be installed and operated as a system. Any alteration to or substitution for items in this system, unless allowed by these installation instructions, will void the Underwriters Laboratories listing and may void the product warranty. It may also create a hazardous installation. Read through these instructions thoroughly before starting your installation and follow them carefully throughout your project.

WARNING!

Do not use this appliance if any part has been under water. Immediately call a qualified service technician to inspect the appliance and to replace any part of the control system and any gas control which has been under water.

B. Description of the Imperial Gas Log Set

The HEATILATOR® Imperial Gas Log Set consists of the following:

1. Burner/Hearth Assembly
2. Grate Assembly
3. Four Fiber Logs

Optional components include:

RC-BATT-HTL Remote Control (M-Series only)

Imperial Series Nomenclature

| Fi42ML | Logset Order Code Number |
|-----------|---------------------------|
| Fi | Imperial Series Log Set |
| 36 | 36" Log Set |
| 42 | 42" Log Set |
| M | Intermittent Pilot |
| S | Safety Pilot Manual Valve |
| No Suffix | Natural Gas |
| L | Propane Gas |

Tools and building supplies normally required for installation:

Pliers
Phillips screwdriver
Tape measure
Crescent wrenches
Non-corrosive leak-check solution

Note: The illustrations and diagrams used throughout these installation instructions are not drawn to scale.

These gas log sets are available with different valve systems. The Fi36S, Fi36SL, Fi42S and Fi42SL sets use a separate regulator and valve system, and the Fi36M, Fi36ML, Fi42M and Fi42ML sets use a combination control with an intermittent pilot. Both valve systems are available in natural or propane gas. Only the "M" Series can be used with an optional remote control (RC-BATT-HTL).

Conversion kits to convert from natural gas to propane or from propane to natural gas are available.

- The conversion kits for all "M" series log sets are:
 - **DCKP** to convert from natural gas to propane
 - **DCKN** to convert from propane to natural gas.
- The conversion kits for all "S" series log sets are:
 - **CKMP** to convert from natural to propane gas
 - **CKMN** to convert from propane to natural gas.

These HEATILATOR® gas log sets and components have been tested and will operate safely when installed in accordance with this installation manual. This decorative appliance is a highly engineered system. Unless you use HEATILATOR® components which have been designed for the system, you may create a fire hazard.

| Model No. | BTU/Hr. Input | Orifice |
|-----------|---------------|---------|
| Fi36M | 60,000 | .152 |
| Fi36ML | | .093 |
| Fi36S | | .169 |
| Fi36SL | | .093 |
| Fi42M | 80,000 | .182 |
| Fi42ML | | .110 |
| Fi42S | | .228 |
| Fi42SL | | .110 |

| Gas Pressure | |
|--------------------------------|----------------------------------|
| Inlet gas supply pressure (NG) | 4.5 (min) - 7.0 (max) in. w.c. |
| Optimal manifold pressure (NG) | 3.5 in. w.c. |
| Inlet gas supply pressure (LP) | 11.0 (min) - 14.0 (max) in. w.c. |
| Optimum manifold pressure (LP) | 10 in. w.c. |

 **WARNING:** This product and the fuels used to operate this product (liquid propane or natural gas), and the products of combustion of such fuels, can expose you to chemicals including benzene, which is known to the State of California to cause cancer and reproductive harm. For more information go to: www.P65Warnings.ca.gov.

C. Important Information

Installer: Please leave these instructions with the owner.

Owner: Please retain these instructions for future reference.

Important: Read these instructions carefully before making installation.

- This appliance must be installed only in a solid-fuel burning (woodburning) fireplace with a working flue and constructed of noncombustible materials.
- The appliance area must be kept clear and free from combustible materials, gasoline and other flammable vapors and liquids.
- A fireplace screen must be in place when the log set is burning and, unless other provisions for combustion air are provided, the screen shall have an opening(s) for introduction of combustion air.
- Installation and the provisions for combustion and ventilation air must conform with the latest edition of the **National Fuel Gas Code ANSI Z223.1** or in Canada, the current **CAN/CGA-B149.1 and B149.2**.
- Inlet and outlet taps are provided on the gas control (M Series) for a test gauge connection. Replace the plug after the test.
- The appliance and its manual shutoff valve must be disconnected from the gas supply piping system during any pressure testing of that system at test pressures in excess of 1/2 PSIG.
- The appliance must be isolated from the gas supply piping system by closing its individual manual shutoff valve during any pressure testing of the gas supply pipe system at test pressure equal to or less than 1/2 PSIG.
- The minimum size fireplace in which the log set can be installed and the minimum permanent free opening that must be provided by either the fireplace chimney or chimney damper to vent the flue gases must be in accordance with the tables in Figure 1.
- Any chimney damper must be fixed so that the minimum permanent vent opening will be maintained at all times (by screw, bolt at damper edge, or hole in damper.)
- Solid fuel shall not be burned in a fireplace where a decorative gas appliance is installed.

1. High Altitude Installation

For U.S. installation, appliances are tested and approved for elevations from 0-2000 feet. When installing this Imperial Gas Log Set at an elevation above 2000 feet, National Fuel Gas Codes require a decrease of the input rating by changing the existing burner orifice to a smaller size. Input should be reduced 4% for each 1000 feet above sea level. Check with the local gas utility for proper orifice size identification. The current orifice is available from your Heatilator distributor.

For Canada, appliances are certified for elevations from 0-4500 feet. When installing this Imperial Gas Log Set at an elevation between 0-4500 feet in Canada, the input rating does not need to be reduced. When installing this log set at an elevation above 4500 feet in Canada, check with local authorities.

2. Minimum Dimensions

| Minimum Firebox Dimensions | | | | Minimum Permanent Free Opening | | |
|----------------------------|--------|--------|---------------|--------------------------------|-----------|-----------|
| Set Size | Depth | Height | Front Opening | Chimney Ht. (ft) | 36 in. | 42 in. |
| 36 in. | 13 in. | 16 in. | 30 in. | 10 ft | 40 sq in. | 40 sq in. |
| 42 in. | 13 in. | 16 in. | 34 in. | | | |

Figure 1

The first name in fireplaces

D. Step-by-Step Installation

1. Unpack the Log Set

Carefully remove all parts from the shipping container. Your set includes four fiber logs, a burner assembly, the grate assembly, fire embers, lava rock, damper stop, and 10" flex connector.

2. Install the Damper Stop

To install the damper stop: Open the damper to the fully open position and secure it open with the stop as shown in Figure 2.

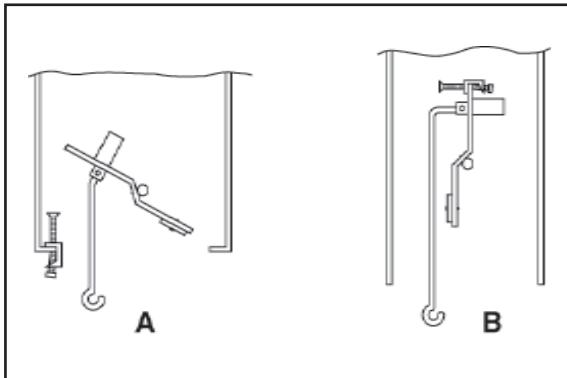

Figure 2 - Damper Operation

If the damper stop doesn't fit your application, use a permanent means that will keep the damper open at least to the minimum vent opening. See Figure 1.

3. Position the Log Set in the Fireplace

The burner assembly should be located as far back as possible and centered left to right in the combustion chamber of the vented fireplace.

4. Connect the Gas Line

The appliance is provided with a stainless steel flexible connector and a listed (and Commonwealth of Massachusetts approved) T-handle manual shutoff valve.

- a. Remove the four screws that secure the burner assembly to the top pan. See Figure 3.



Figure 3 - Burner Assembly

- b. Remove the four screws that secure the top pan to the base of the appliance. See Figure 4.



Figure 4 - Top Pan

- c. Set the burner assembly and top pan aside.
- d. The gas line connection for the Imperial Series Gas Log Set may be plumbed from either the right or left side of the appliance.

Note: This appliance must be installed with a manual shutoff valve (not supplied) located no more than six feet from the appliance.

- e. The 1/2" iron pipe incoming gas line should be piped into the valve compartment from either the right or left side and connected to the brass flare connector and the 10" stainless steel flex line (supplied). See Figure 5.

Optional: Seal around the gas line to prevent cold air leakage.



Figure 5 - Gas Line Connection

Note: Have the gas supply line installed in accordance with building codes by a qualified installer approved and/or licensed as required by the locality. In the Commonwealth of Massachusetts, installation must be performed by a licensed plumber or gas fitter.

- f. Bleed the gas line to extract any air that may have been trapped inside the pipe. All connections must be tightened and checked for leaks with a commercially available, non-corrosive leak check solution. Be sure to rinse off the solution when done leak testing. **DO NOT USE AN OPEN FLAME.** Turn off the gas after the leak test.
- g. Reassemble the top pan with the four screws removed earlier, and the burner assembly with the four screws removed earlier.

Note: Be sure when reassembling the burner assembly that the burner neck is properly positioned on the orifice.



Figure 7 - Rock Wool Placement

5. Grate Assembly

The grate assembly should be positioned on top of the top pan and the burner assemblies, centered from left to right and pulled forward as far as possible. See Figure 6.



Figure 6 - Placing the Grate Assembly

6. Place the Rock Wool, Fire Glow, Lava Rock and Vermiculite

- a. Rock Wool
Place approximately 1/2" diameter pieces of rock wool on the top of the burner covering the front 2/3 of the burner. Do not cover the rear row of burner ports. The rock wool should also be placed to the sides of the burner on the top pan and under the front bar of the grate assembly to hide the burner. See Figure 7.
- b. Fire Glow (Fire 98)
A flame colorant material that also adds to the realism of the gas appliance flame. After placing the rock wool, sprinkle some of the Fire Glow on the top of the burner assembly and the rock wool.

c. Lava Rock

Place on the hearth refractory of the fireplace, all around the log set. See Figure 8.



Figure 8 - Lava Rock

- d. Vermiculite
When placing the vermiculite, sprinkle it evenly over the area covered by the lava rock.
- e. It is not necessary to use the entire bag of the rock wool, the Fire Glow, the lava rock or the vermiculite. Save the remaining portions for later use.

The first name in fireplaces

7. Place the Logs

a. Rear Log

The rear log is supplied with locating slots in the base of the log. Locate the rear log over the locating tabs at the rear of the top pan. See Figure 9.



Figure 9 - Rear Log Placement

c. Top Right Log

The top right log is supplied with locating slots in the base of the log. Locate the log over the two locating pins found in the rear log and the front log. See Figure 11.



Figure 11 - Top Right Log

b. Front Log

The front log is supplied with notches in the base of the log to locate the log on the grate. Line up the notches in the log with the grate bars and pull the log forward until it comes into contact with the upright portion of the grate bars. See Figure 10.



Figure 10 - Placing the Front Log

d. Top Left Log

The top left log is supplied with a locating tab that fits into a notch on the top of the front log. See Figure 12.



Figure 12 - Top Left Log

8. Intermittent Pilot Ignition

- a. Appliance Requirements: This appliance does not require 110VAC supply for operation.
- 1) A wiring diagram is shown in Figure 13. A battery pack is supplied with the appliance. This appliance requires the use of two D-cell batteries (not supplied with the appliance) for operation.
 - 2) In the event of a power outage, the appliance will continue to operate if batteries are installed in the battery pack.

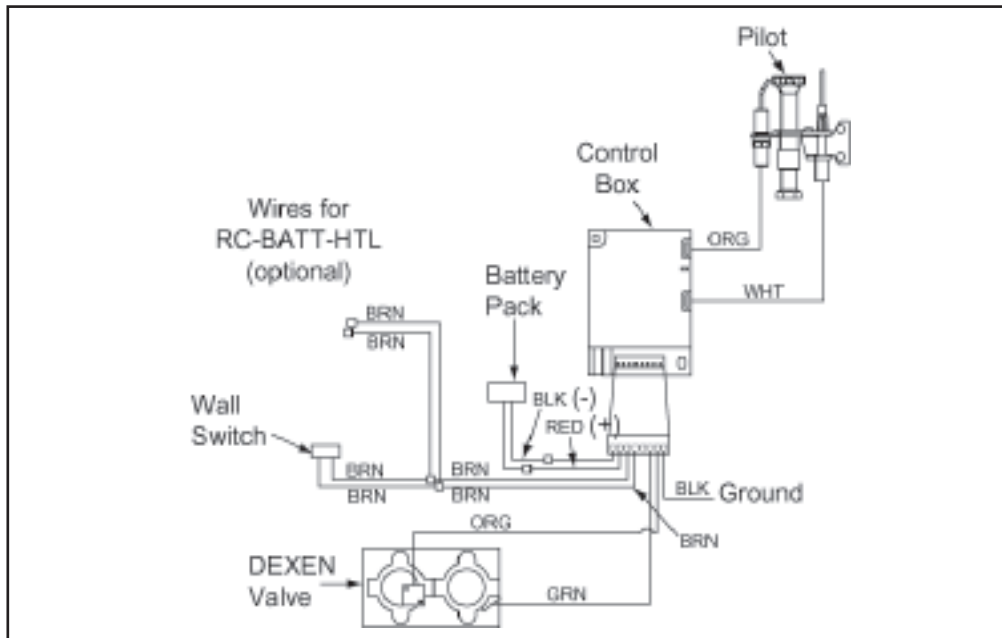

Figure 13 - "M" Series Intermittent Pilot Wiring Diagram

b. Battery Replacement

- 1) Access Cover - Remove the access cover by locating the two hand tabs on either side of the access cover. Slide the access cover to the right approximately 1" to disengage it from the base. See Figure 14.
- 2) Battery Pack - Locate the battery pack and slide it forward out of the base. See Figure 15. Replace batteries and reinstall the battery pack into the base. The battery pack is held in place by a magnet located on the base pan.



Figure 14 - Access Cover Removal



Figure 15 - Battery Replacement

The first name in fireplaces

E. Operating Instructions for the “M” Series

FOR YOUR SAFETY READ BEFORE LIGHTING

WARNING: If you do not follow these instructions exactly, a fire or explosion may result causing property damage, personal injury or loss of life.

A. This appliance has an intermittent pilot. When lighting the pilot, follow these instructions exactly.

B. BEFORE LIGHTING smell all around the appliance area for gas. Be sure to smell next to the floor because some gas is heavier than air and will settle to the floor.

WHAT TO DO IF YOU SMELL GAS

- Do not try to light any appliance.
- Do not touch any electric switch; do not use any phone in your building.
- Immediately call your gas supplier from a neighbor’s phone. Follow the gas supplier’s instructions.
- If you cannot reach your gas supplier, call the fire department.

C. Do not use this appliance if any part has been under water. Immediately call a qualified service technician to inspect the appliance and to replace any part of the control system and any gas control which has been under water.

Due to high surface temperatures, keep children, clothing and furniture away.
Keep burner and control compartment clean. See installation and operating instructions accompanying the appliance.

FOR YOUR SAFETY: Do not store or use gasoline or other flammable vapors and liquids in the vicinity of this or any other appliance.

LIGHTING INSTRUCTIONS

1. STOP! Read the safety instruction label.
2. Turn wall switch to the "OFF" position.
3. Wait five minutes to clear out any gas. If you smell gas, STOP! Follow "B" on the safety information label. If you don't smell gas, go to next step.
4. Locate pilot assembly inside unit.
5. To light pilot and main burner, turn wall switch to "ON". Do not light by hand.
6. If appliance will not operate, follow the instructions "TO TURN OFF GAS TO APPLIANCE" and call your service technician or gas supplier.

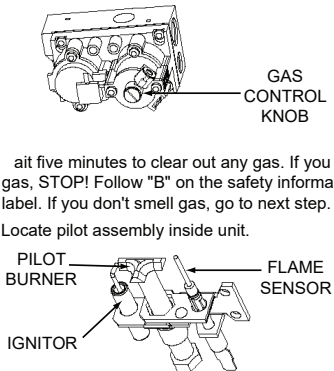

WARNING: This product and the fuels used to operate this product (liquid propane or natural gas), and the products of combustion of such fuels, can expose you to chemicals including benzene, which is known to the State of California to cause cancer and reproductive harm. For more information go to: www.P65Warnings.ca.gov.

TO TURN OFF GAS APPLIANCE

1. Turn on/off switch to "OFF".

34006

F. Operating Instructions for the "S" Series

FOR YOUR SAFETY READ BEFORE LIGHTING

WARNING: If you do not follow these instructions exactly, a fire or explosion may result causing property damage, personal injury or loss of life.

- A. This appliance has a pilot which must be lit by hand. When lighting the pilot, follow these instructions exactly.
- B. BEFORE LIGHTING smell all around the appliance area for gas. Be sure to smell next to the floor because some gas is heavier than air and will settle to the floor.
WHAT TO DO IF YOU SMELL GAS
 - Do not try to light any appliance.
 - Do not touch any electric switch; do not use any phone in your building.
 - Immediately call your gas supplier?from a neighbor's phone. Follow the gas supplier's instructions.
 - If you cannot reach your gas supplier, call the fire department.
- C. Use only your hand to push in or turn the gas control knob. Never use tools. If the knob will not push in or turn by hand, don't try to repair it, call a qualified service technician. Force or attempted repair may result in a fire or explosion.
- D. Do not use this appliance if any part has been under water. Immediately call a qualified service technician to inspect the appliance and to replace any part of the control system and any gas control which has been under water.

Due to high surface temperatures, keep children, clothing and furniture away.

Keep burner and control compartment clean. See installation and operating instructions accompanying the appliance.

FOR YOUR SAFETY: Do not store or use gasoline or other flammable vapors and liquids in the vicinity of this or any other appliance.

LIGHTING INSTRUCTIONS

1. STOP! Read the safety instruction label.
2. Turn gas control clockwise to "OFF".

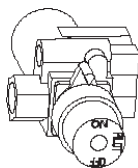

3. Wait five minutes to clear out any gas. If you smell gas, STOP! Follow "B" on the safety information label. If you don't smell gas, go to next step.
4. Find pilot--follow metal tube from gas control. The pilot is behind the burner pan.

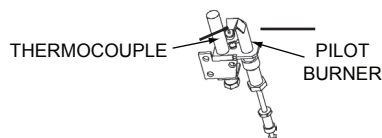

5. Turn knob on control counterclockwise to "PILOT".
6. Push in the knob all the way and hold in. Immediately light the pilot with the use of a paper match and lighter rod. Continue to hold the control knob in for about one minute after the pilot is lit. Release button and it will pop back up. Pilot should remain lit. If it goes out, repeat steps 3 through 7.
If button does not pop up when released, stop and immediately call your service technician or gas supplier. If the pilot will not stay lit after several tries, turn the gas control knob to "OFF" and call your service technician or gas supplier.
7. Turn gas control knob counterclockwise to "ON". Knob can be turned to "ON" only if the control knob is popped out.

TO TURN OFF GAS APPLIANCE

1. Turn gas control clockwise to "OFF". Do not force.

34008

The first name in fireplaces

G. Glass Doors

If your fireplace is equipped with a glass door, the glass doors should be in the full open position when the appliance is operating. Operating the fireplace with the glass doors closed will block the radiant heat output of the fireplace and may cause incomplete combustion of the natural or propane gas fuel.

IMPORTANT! Always ensure that the wire fireplace screen is closed when the fireplace is operating.

H. Cleaning

Your gas logs require little care. Keep the burner assembly, logs and burner area surrounding the logs clean by vacuuming or brushing with a dry paint brush at least twice a year.

CAUTION:
The logs can get very hot. Handle only when they are cool.

CAUTION:
After burning, the log becomes fragile, so take care in handling.

- Always turn off the gas to the pilot before cleaning. For relighting, refer to lighting instructions located on pages 10 and 11.
- Always keep the appliance clear and free from combustible materials, gasoline, and other flammable vapors and liquids.
- Never obstruct the flow of combustion and ventilation air. Keep the front of the appliance clear of all obstacles and materials.
- Leave clearance of at least 36" from the front of the fireplace.
- The air shutter should not be blocked.

I. Inspecting the Venting System

The fireplace venting system is designed and constructed to develop a positive flow adequate to remove flue gases to the outside atmosphere. See vented fireplace installation instructions.

1. A spillage test must be made before the installed appliance is left with the consumer.

- a. Close all doors and windows in the home.
- b. Light the log set.
- c. After three minutes, test with a smoke match, smoke candle, stick incense, or cigarette 1" below the top of the opening (lintel) moving across the full width. See Figure 16. If spillage (smoke drawn into the room) occurs, it will most likely be near the top, outside corners.



Figure 16 - Checking for Spillage

2. Possible Cures

- a. The damper needs to be opened further.
- b. The fireplace opening needs to be reduced by adding a drop panel across the top under the lintel.
- c. The air supply from outdoors needs to be increased. Open the outside air kit if the fireplace is so equipped, or crack open a door or window.
- d. If necessary, seek expert advice. Do not operate this appliance.

3. Cleaning

Periodic examination and cleaning of the venting system of the solid-fuel burning fireplace should be done before initial use and at least annually by a qualified agency.

J. Important Safeguards

1. Other Fuels

- a. Although your gas log set is very realistic in appearance, it is not a real woodburning fire and must not be used for burning any fuel other than natural or propane gas.
- b. To avoid irreparable damage to the appliance and/or personal injury, wood, matches, paper, garbage or any other material must not be placed or thrown on top of the logs.

2. Fireplace Safety

- a. To avoid personal injury, do not touch hot surfaces when the appliance is operating.
- b. Always ensure that the fireplace screen is closed when the appliance is operating.
- c. Close supervision is necessary when the appliance is being used near children.

K. Servicing

- Repair and replacement work should be done by a qualified service technician.
- Always shut off the gas supply and make sure the appliance is cool before beginning any service operation.
- Always check for gas leaks after servicing.
- Always check for proper venting.

L. Owner Registration/Warranty

Please complete and return your owner registration card to ensure proper warranty coverage. If you wish to communicate with the factory, write to Heatilator Technical Services Dept., Hearth & Home Technologies Inc., 1915 W. Saunders Street, Mt. Pleasant, Iowa 52641

M. Replacement Parts

Parts lists with exploded views follow. Always include correct name, part number and model number of the appliance when ordering replacement parts. Contact your local dealer to order parts.

The first name in fireplaces

Log Set Assembly

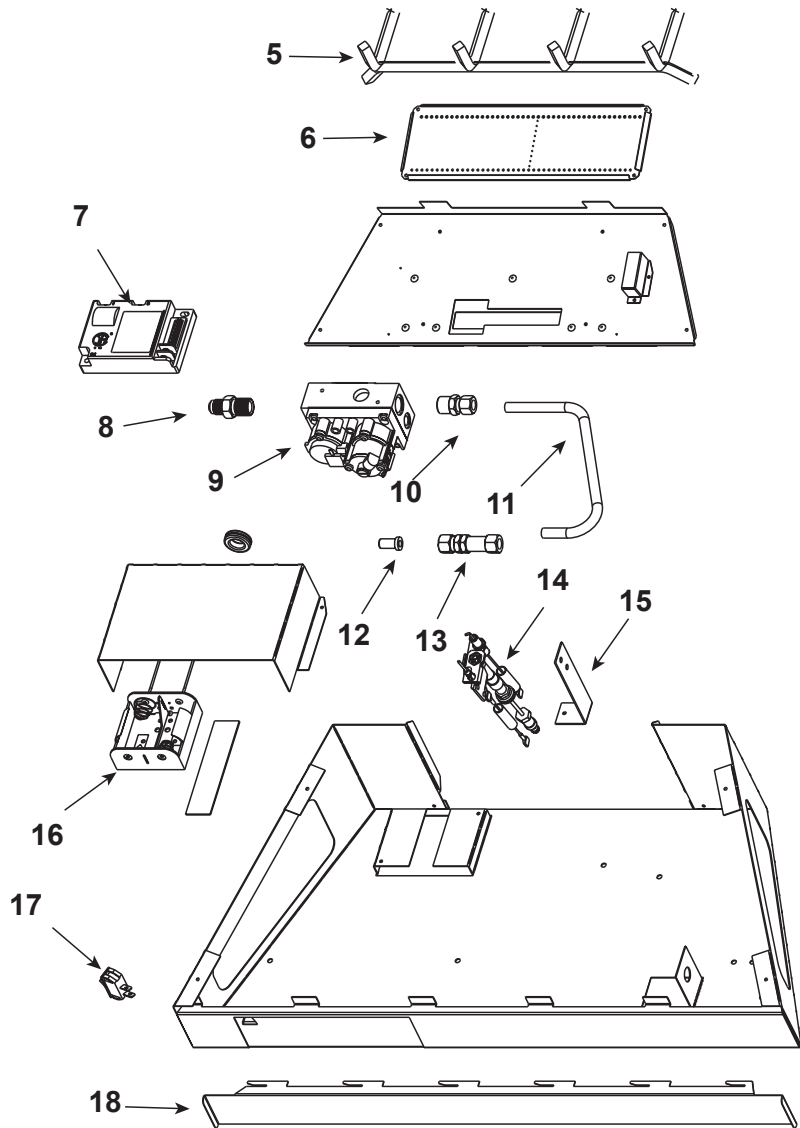
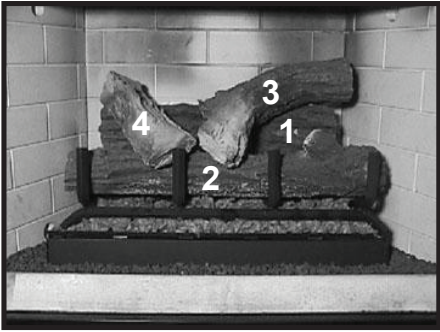

Part number list on following page.

02/21

IMPORTANT: THIS IS DATED INFORMATION. Parts must be ordered from a dealer or distributor. **Hearth and Home Technologies does not sell directly to consumers.** Provide model number and serial number when requesting service parts from your dealer or distributor.



**Stocked
at Depot**

| ITEM | DESCRIPTION | COMMENTS | PART NUMBER | |
|------|--------------------------------|---------------------------------|-------------|---|
| 1 | Back Log | Pre 5/15/16 must order all logs | SRV32233 | |
| 2 | Front Log | | SRV32234 | |
| 3 | Top Right Log | | SRV33732 | |
| 4 | Top Left Log | | SRV33733 | |
| 5 | Grate Assembly | | 33743 | |
| 6 | Burner Assembly | | 33725 | Y |
| 7 | Control Module | | SRV593-595 | Y |
| 8 | Brass Connector | Pkg of 5 | 303-315/5 | Y |
| 9 | Valve NG | | SRV593-500 | Y |
| | Valve LP | | SRV593-501 | Y |
| 10 | Brass Male Connector | | 13425 | |
| 11 | Gas Tube | | 33729 | |
| 12 | Orifice NG (.152) | | 32229 | Y |
| | Orifice LP (.093) | | SRV16752 | Y |
| 13 | Bulkhead | | SRV13405 | |
| 14 | Pilot Assembly NG | | SRV4021-730 | Y |
| | Pilot Assembly LP | | SRV4021-731 | Y |
| 15 | Pilot Bracket | | 33375 | |
| 16 | Battery Pack | | SRV593-594 | Y |
| 17 | ON/OFF Rocker Switch | | SRV060-511 | |
| 18 | Access Cover | | 32238 | |
| | Damper Stop Assembly | | 14354 | Y |
| | Flex Gas Line | | SRV4121-006 | Y |
| | Dexen Wire Harness | | SRV593-590 | Y |
| | Wool, Rock, Vermiculite | | 34010 | |
| | Lava Rock (2lb. Bag) | | 4021-296 | |
| | Mineral Wool | | SRV14333 | |
| | Vermiculite | | 28746 | |
| | "Z" Bracket | | 32228 | |
| | Wire Harness | Qty 2 req | 33995 | |
| | Conversion Kit NG | | DCKN | Y |
| | Conversion Kit LP | | DCKP | Y |
| | Pilot Orifice NG, .021 | | SRV446-505 | Y |
| | Pilot Orifice LP, .011 | | SRV446-517 | Y |
| | Regulator NG | | SRVNGK-DXF | Y |
| | Regulator LP | | SRVLPK-DXF | Y |
| | Installation Manual | | 33734 | |

Log Set Assembly

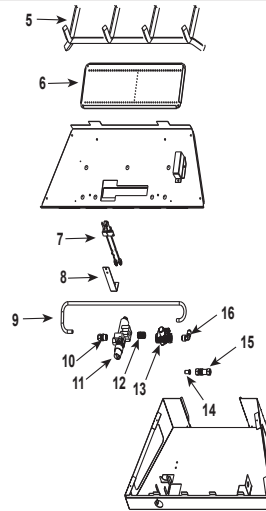
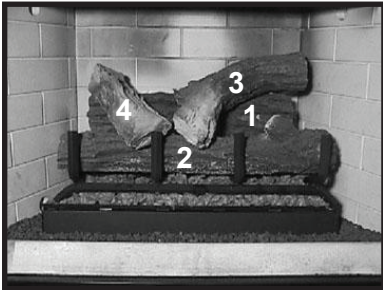

IMPORTANT: THIS IS DATED INFORMATION. Parts must be ordered from a dealer or distributor. **Hearth and Home Technologies does not sell directly to consumers.** Provide model number and serial number when requesting service parts from your dealer or distributor.



Stocked at Depot

| ITEM | DESCRIPTION | COMMENTS | PART NUMBER | |
|------|------------------------------------|---------------------|-------------|---|
| 1 | Back Log | | SRV32233 | |
| 2 | Front Log | | SRV32234 | |
| 3 | Top Right Log | | SRV33732 | |
| 4 | Top Left Log | | SRV33733 | |
| 5 | Grate Assembly | | 33743 | |
| 6 | Burner Assembly | | 33725 | Y |
| 7 | Pilot Assembly NG | No longer available | 33993 | |
| | Pilot Assembly LP | No longer available | 33994 | |
| 8 | Pilot Bracket | No longer available | 33735 | |
| 9 | Gas Tube | No longer available | 33989 | |
| 10 | Brass Male Connector | | 13425 | |
| 11 | Valve | No longer available | 33992 | |
| 12 | Pipe Nipple | No longer available | SRV4021-041 | |
| 13 | Regulator | No longer available | 34028 | |
| 14 | Orifice NG (.169) | No longer available | 18742 | |
| | Orifice LP (.093) | | SRV16752 | Y |
| 15 | Brass Bulkhead | | SRV13405 | Y |
| 16 | Brass Connector - 90 degree - Flex | | SRV4021-045 | |
| | Brass Connector | Pkg of 5 | 303-315/5 | Y |
| | Damper Stop Assembly | | 14354 | Y |
| | 10 in. Flexline | | SRV302-320 | Y |
| | Wool, Rock, Vermiculite | | 34010 | |
| | Lava Rock (2lb. Bag) | | 4021-296 | |
| | Mineral Wool | | SRV14333 | |
| | Vermiculite | | 28746 | |
| | Conversion Kit NG | No longer available | CKMN | |
| | Conversion Kit LP | No longer available | CKMP | |

Log Set Assembly

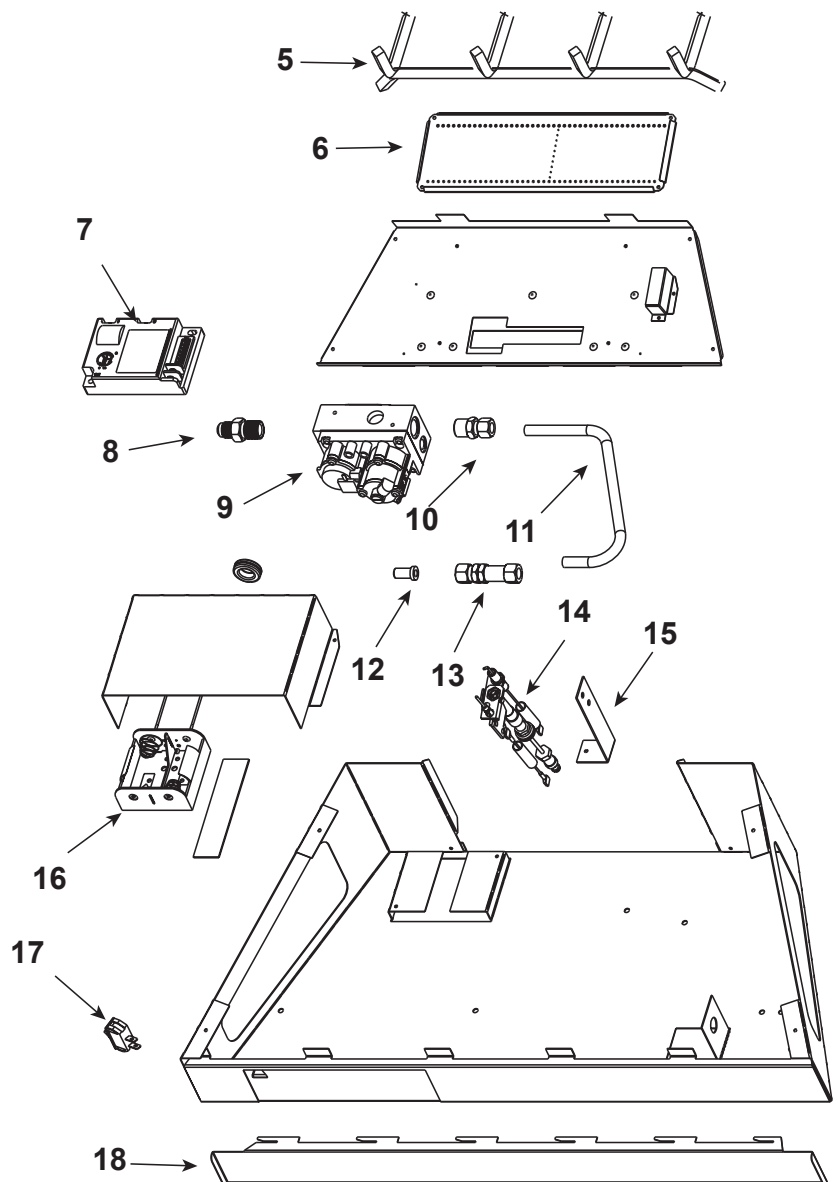
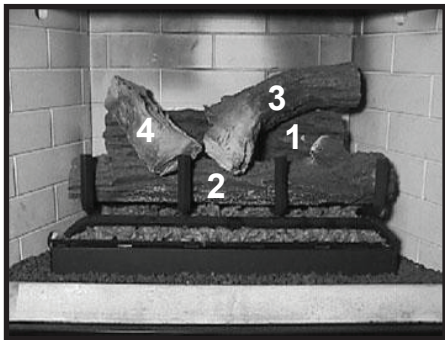

Part number list on following page.

02/21

IMPORTANT: THIS IS DATED INFORMATION. When requesting service or replacement parts for your appliance please provide model number and serial number. All parts listed in this manual may be ordered from an authorized dealer.



**Stocked
at Depot**

| ITEM | DESCRIPTION | COMMENTS | PART NUMBER | |
|------|--------------------------------|------------------------------------|-------------|---|
| 1 | Back Log | Pre 5/15/16 must order all logs | SRV32233 | |
| 2 | Front Log | | SRV32234 | |
| 3 | Top Right Log | | SRV33732 | |
| 4 | Top Left Log | | SRV33733 | |
| 5 | Grate Assembly | | 33743 | |
| 6 | Burner Assembly | | 33725 | Y |
| 7 | Control Module | | SRV593-595 | Y |
| 8 | Brass Connector | Pkg of 5 | 303-315/5 | Y |
| 9 | Valve NG | | SRV593-500 | Y |
| | Valve LP | | SRV593-501 | Y |
| 10 | Brass Male Connector | | 13425 | |
| 11 | Gas Tube | | 33729 | |
| 12 | Orifice NG (.182) | | 32230 | |
| | Orifice LP (.110) | | SRV17235 | Y |
| 13 | Bulkhead | | SRV13405 | |
| 14 | Pilot Assembly NG | | SRV4021-730 | Y |
| | Pilot Assembly LP | | SRV4021-731 | Y |
| 15 | Pilot Bracket | | 33375 | |
| 16 | Battery Pack | | SRV593-594 | Y |
| 17 | ON/OFF Rocker Switch | | SRV060-511 | Y |
| 18 | Access Cover | | 32238 | |
| | Damper Stop Assembly | | 14354 | Y |
| | Flex Gas Line | | SRV4121-006 | Y |
| | Dexen Wire Harness | | SRV593-590 | Y |
| | Wool, Rock, Vermiculite | | 34010 | |
| | Lava Rock (2lb. Bag) | | 4021-296 | |
| | Mineral Wool | | SRV14333 | |
| | Vermiculite | | 28746 | |
| | "Z" Bracket | | 32228 | |
| | Wire Harness | Qty 2 req | 33995 | |
| | Conversion Kit NG | | DCKN | Y |
| | Conversion Kit LP | | DCKP | Y |
| | Pilot Orifice NG, .021 | | SRV446-505 | Y |
| | Pilot Orifice LP, .011 | | SRV446-517 | Y |
| | Regulator NG | | SRVNGK-DXF | Y |
| | Regulator LP | | SRVLPK-DXF | Y |
| | Installation Manual | | 33734 | |

Log Set Assembly

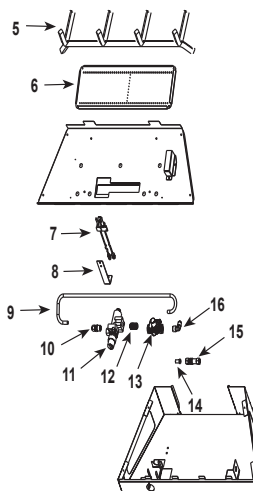

IMPORTANT: THIS IS DATED INFORMATION. Parts must be ordered from a dealer or distributor. **Hearth and Home Technologies does not sell directly to consumers.** Provide model number and serial number when requesting service parts from your dealer or distributor.



Stocked at Depot

| ITEM | DESCRIPTION | COMMENTS | PART NUMBER | |
|------|------------------------------------|---------------------|-------------|---|
| 1 | Back Log | | SRV32233 | |
| 2 | Front Log | | SRV32234 | |
| 3 | Top Right Log | | SRV33732 | |
| 4 | Top Left Log | | SRV33733 | |
| 5 | Grate Assembly | | 33743 | |
| 6 | Burner Assembly | | 33725 | Y |
| 7 | Pilot Assembly NG | No longer available | 33993 | |
| | Pilot Assembly LP | No longer available | 33994 | |
| 8 | Pilot Bracket | No longer available | 33735 | |
| 9 | Gas Tube | No longer available | 33989 | |
| 10 | Brass Male Connector | | 13425 | |
| 11 | Valve | No longer available | 33992 | |
| 12 | Pipe Nipple | No longer available | SRV4021-041 | |
| 13 | Regulator | No longer available | 34028 | |
| 14 | Orifice NG (.228) | No longer available | 33736 | |
| | Orifice LP (.110) | | SRV17235 | Y |
| 15 | Brass Bulkhead | | SRV13405 | Y |
| 16 | Brass Connector - 90 degree - Flex | | SRV4021-045 | |
| | Brass Connector | Pkg of 5 | 303-315/5 | Y |
| | Damper Stop Assembly | | 14354 | Y |
| | 10 in. Flexline | | SRV302-320 | Y |
| | Wool, Rock, Vermiculite | | 34010 | |
| | Lava Rock (2lb. Bag) | | 4021-296 | |
| | Mineral Wool | | SRV14333 | |
| | Vermiculite | | 28746 | |
| | Conversion Kit NG | No longer available | CKMN | |
| | Conversion Kit LP | No longer available | CKMP | |

N. Troubleshooting - "M" Series

With proper installation and maintenance, your new decorative gas appliance should provide years of trouble-free service. If you do experience a problem, refer to the troubleshooting guide below. This guide will assist you or a qualified service technician in the diagnosis of problems and the corrective action to be taken.

| Symptoms | Possible Causes | Corrective Action |
|---|--|---|
| 1 Pilot sparks, but will not light after repeated attempts. | a. Main gas shutoff valve closed. | Make sure that the shutoff valve located on the incoming gas line is open. |
| | b. Air in the gas line. | Bleed air out of the gas line. Retest for gas leaks after bleeding. |
| | c. Pilot orifice is plugged, not allowing gas to flow. | This repair requires tools and some degree of experience. Call a qualified service technician. |
| | d. Misaligned electrode. | Check spark gap; spark should be extending approximately 1/8" to the pilot hood. Adjust gap to give proper spark. Remove hands from electrode before attempting to spark. |
| | e. No gas supply to the appliance. | Check plumbing to ensure the appliance has been hooked up to the gas supply line. The propane tank is empty. |
| | f. Ground wire loose. | Check that the black ground wire from the ignition control box is securely attached to the ground. |
| | g. Weak batteries. | Replace with two new "D" sized batteries. |
| 2 Pilot lights, but will not stay lit. | a. Weak pilot flame. | Pilot flame must engulf the flame sensor. Clean and/or adjust pilot for maximum flame impingement on flame sensor. |
| | b. Loose wire connection | Check for loose wires from the pilot to the ignition control box. |
| | c. Faulty flame sensor. | Check the wire connection into the ignition control box. If the connection is correct, replace sensor. |
| 3 Pilot does not spark at all. | a. Loose wire connection. | Check for loose wires from On/Off switch to ignition control and remote control. |
| | b. Remote control. | Make sure the switch located on the front of the remote control is set to the "Remote" setting. |
| | c. Weak batteries. | Replace with two new "D" sized batteries. |

The first name in fireplaces

O. TROUBLESHOOTING - "S" SERIES

| Symptoms | Possible Causes | Corrective Action |
|--|---|---|
| 1 Match will not light pilot. | a. Main gas shutoff valve closed. | Make sure that the shutoff valve located on the incoming gas line is open. |
| | b. Air in the gas line. | Light a match. Turn valve knob to "PILOT" position and depress. Keep match near pilot burner until it lights. |
| | c. Valve knob is in "OFF" position | Turn valve knob to "PILOT" position and depress. Keep match near pilot burner until it lights. |
| | d. Pilot orifice is plugged, not allowing gas to flow | This repair requires tools and some degree of experience. Call a qualified service technician. |
| | e. No gas supply to the appliance. | Check the plumbing to ensure the appliance has been hooked up to the gas supply line. |
| 2 Pilot lights, but will not stay lit after carefully following lighting instructions. | a. Thermocouple too tight or too loose. | Thermocouple must be attached to the valve finger-tight, plus a 1/8 turn with a wrench. |
| | b. Weak pilot flame. | Pilot flame must engulf the thermocouple. Clean and/or adjust pilot for maximum flame impingement on the thermocouple. |
| | c. Defective thermocouple. | Check the thermocouple with a millivolt meter as follows: Disconnect the thermocouple from the valve and connect the red lead of the meter to the silver end of the thermocouple. Now connect the black lead of the meter to the copper tubing of the thermocouple. Light the pilot and keep the knob depressed while taking readings. The meter readings should be greater than 14 mV. If not, replace thermocouple. |
| 3 Pilot "ON". No gas to main burner, valve knob "ON". | a. A blockage is preventing gas flow. | Inspect the burner orifice for obstruction. Call a qualified service technician. |
| | b. Defective valve. | Replace gas valve. Call a qualified service technician. |

The first name in fireplaces

P. Accessory Parts (For “M” Series Only)

The following accessory parts can be obtained from your dealer. The wireless remote control switch is supplied with installation instructions packaged with them. Should you need additional information please contact your dealer for more information or visit: www.hpba.org/staysafe.

Remote Control

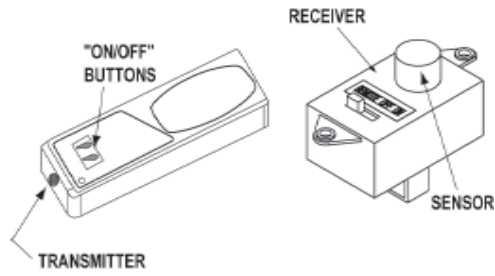

RC-BATT-HTL

The first name in fireplaces

Hearth & Home Technologies LLC
LIMITED LIFETIME WARRANTY

Hearth & Home Technologies LLC (“HHT”) extends the following warranty for HHT gas, wood, pellet and electric hearth appliances (each a “Product” and collectively, the “Product(s)”) and certain component parts set forth in the table below (“Component Part(s)”) that are purchased from a HHT authorized dealer or distributor.

WARRANTY COVERAGE:

HHT warrants that the Products and their Component Parts will be free from defects in materials and workmanship for the applicable period of Warranty coverage set forth in the table below (“Warranty Period”). If a Product or Component Parts are found to be defective in materials or workmanship during the applicable Warranty Period, HHT will, at its option, repair the applicable Component Part(s), replace the applicable Component Part(s), or refund the purchase price of the applicable Product(s). The maximum amount recoverable under this Warranty is limited to the purchase price of the Product. This Warranty is transferable from the original purchaser to subsequent owners, but the Warranty Period will not be extended in duration or expanded in coverage for any such transfer. This Warranty is subject to conditions, exclusions, and limitations as described below.

WARRANTY PERIOD:

Warranty coverage begins at the date of installation. In the case of new home constructions, Warranty coverage begins on the date of first occupancy of the dwelling or six months after the sale of the Product(s) by an independent, authorized HHT dealer or distributor, whichever occurs earlier. However, the Warranty coverage shall commence no later than 24 months following the date of Product shipment from HHT, regardless of the installation or occupancy date.

The term “Lifetime” in the table below is defined as: 20 years from the beginning date of warranty coverage for gas appliances, and 10 years from the beginning date of warranty coverage for wood and pellet appliances. These time periods reflect the minimum expected useful lives of the designated Component Parts under normal operating conditions.

| Warranty Period | | HHT Manufactured Appliances and Venting | | | | | |
|------------------|---------|---|--------|------|----------|---------|---|
| Component Parts | Labor | Gas | Pellet | Wood | Electric | Venting | Component Parts Covered by this Warranty |
| 1 Year | | X | X | X | | X | All parts including handles, external enameled components and other material except as covered by Warranty Conditions, Warranty Exclusions, and Warranty Limitations listed |
| 2 Years | | | | | X | | All parts except as covered by Warranty Conditions, Warranty Exclusions, and Warranty Limitations listed |
| 2 years | | | X | X | | | Igniters, Auger Motors, Electronic Components, and Glass |
| | | X | | | | | Electrical components limited to modules, remotes/wall switches, valves, pilots, blowers, junction boxes, wire harnesses, transformers and lights (excluding light bulbs) |
| | | X | | X | | | Molded Refractory Panels, Glass Liners |
| 3 years | | | X | | | | Firepots, burnpots, mechanical feeders/auger assemblies |
| 5 years | 1 year | X | | | | | Vent Free Burners, Vent Free Logs |
| | | | X | X | | | Castings, Medallions and Baffles |
| 6 years | 3 years | | | X | | | Catalysts |
| 7 years | 3 years | | X | X | | | Manifold tubes, HHT Chimney and Terminations |
| 10 years | 1 year | X | | | | | Burners, logs and refractory |
| Limited Lifetime | 3 years | X | X | X | | | Firebox and heat exchanger, FlexBurn® System (engine, inner cover, access cover and fireback) |
| 1 Year | None | X | X | X | X | X | All purchased replacement parts |

WARRANTY CONDITIONS:

- Because HHT cannot control the quality of any Products sold by unauthorized sellers, this Warranty only covers Products that are purchased through an HHT authorized dealer or distributor unless otherwise prohibited by law; a list of HHT authorized dealers is available on the HHT branded websites.
- This Warranty is only valid while the applicable Product remains at the site of original installation.
- This Warranty is only valid in the country in which the HHT authorized dealer or distributor that sold the applicable Product is authorized to sell applicable Product.
- Contact your installing distributor or dealer for Warranty service. If the installing dealer or distributor is unable to provide necessary parts, contact the nearest HHT authorized dealer or supplier. Additional service fees may apply if you are seeking Warranty service from a dealer other than the dealer from whom you originally purchased the applicable Product.
- No HHT consumer should bear cost of warranty service or costs incurred while servicing warranty claims (i.e., travel, gas, or mileage) when the service is performed within the terms of this Warranty. Check with your dealer or distributor in advance for any costs to you when arranging a warranty call. Travel and shipping charges for parts are not covered by this Warranty.

WARRANTY EXCLUSIONS:

This Warranty does not cover the following:

- Changes in surface finishes as a result of normal use. As a heating appliance, some changes in color of interior and exterior surface finishes may occur. This is not a flaw and is not covered under the Warranty.
- Damage to printed, plated, or enameled surfaces caused by fingerprints, accidents, misuse, scratches, melted items or other external sources and residues left on the plated surfaces from the use of abrasive cleaners or polishes.
- Repair or replacement of parts that are subject to normal wear and tear during the Warranty Period are not covered. These parts include: paint, wood and pellet gaskets, firebricks, grates, flame guides, batteries and the discoloration of glass.
- Minor expansion, contraction, or movement of certain parts causing noise. These conditions are normal and complaints related to this noise are not covered by this Warranty.
- Damages resulting from: (1) failure to install, operate, or maintain the applicable Product in accordance with the installation instructions, operating instructions, and listing agent identification label furnished with the applicable Product; (2) failure to install the applicable Product in accordance with local building codes; (3) shipping or improper handling; (4) improper operation, abuse, misuse, continued operation with damaged, corroded or failed components, accident, or improperly/incorrectly performed repairs; (5) environmental conditions, inadequate ventilation, negative pressure, or drafting caused by tightly sealed constructions, insufficient make-up air supply, or handling devices such as exhaust fans or forced air furnaces or other such causes; (6) use of fuels other than those specified in the operation instructions; (7) installation or use of components not supplied with the applicable Product or any other components not expressly authorized and approved by HHT; (8) modification of the appliance not expressly authorized and approved by HHT in writing; and/or (9) interruptions or fluctuations of electrical power supply to the applicable Product.
- Non-HHT venting components, hearth connections or other accessories used in conjunction with the applicable Product.
- Any part of a pre-existing fireplace system in which an insert or a decorative gas applicable Product is installed.
- HHT's obligation under this Warranty does not extend to the Product's capability to heat the desired space. Information is provided to assist the consumer and the dealer in selecting the proper Product for the application. Consideration must be given to the Product location and configuration, environmental conditions, insulation and air tightness of the structure.

This warranty is void if:

- The applicable Product has been over-fired, operated in atmospheres contaminated by chlorine, fluorine, or other damaging chemicals. Over-firing can be identified by, but not limited to, warped plates or tubes, deformation/warping of interior cast iron structure or components, rust colored cast iron, bubbling, cracking and discoloration of steel or enamel finishes.
- The applicable Product is subjected to prolonged periods of dampness or condensation.
- There is any damage to the applicable Product due to water or weather damage which is the result of, but not limited to, improper chimney or venting installation.

LIMITATIONS OF REMEDIES AND LIABILITY:

- **EXCEPT TO THE EXTENT PROVIDED BY LAW, HHT MAKES NO EXPRESS WARRANTIES OTHER THAN THE WARRANTY SPECIFIED HEREIN. The owner's exclusive remedy and HHT's sole obligation under this Warranty or in contract, tort or otherwise, shall be limited to replacement of the Component Part(s), repair of the Component Part(s), or refund of the original purchase price of the applicable Product(s), as specified above; provided, however, that (i) if HHT is unable to provide replacement of the Component Part(s) and repair of the Component Part(s) is not commercially practicable or cannot be timely made, or (ii) the customer is willing to accept a refund of the purchase price of the applicable Product(s), HHT may discharge all such obligations by refunding the purchase price of the applicable Product. In no event will HHT be liable for any incidental or consequential damages caused by defects in the applicable Product. Some States do not allow the exclusion or limitation of incidental or consequential damages, so the above limitation or exclusion may not apply to you. This Warranty gives you specific legal rights and you may also have other rights which vary from State to State. THE DURATION OF ANY IMPLIED WARRANTY IS LIMITED TO DURATION OF THE EXPRESSED WARRANTY SPECIFIED ABOVE FOR THE APPLICABLE PRODUCT. Some States do not allow limitations on how long an implied warranty lasts, so the above limitation may not apply to you.**