

## Spare Parts Catalogue

ASKO Washing Machines \ ASKO 6000 Series  
Type: WM70.1  
Model: W6424 US white

Prod. No: 107642400  
March 15th 2012

**ASKO Appliances Inc.**

4001 E Plano Parkway #1004001 E Plano Parkway #100  
Plano, Texas 75074

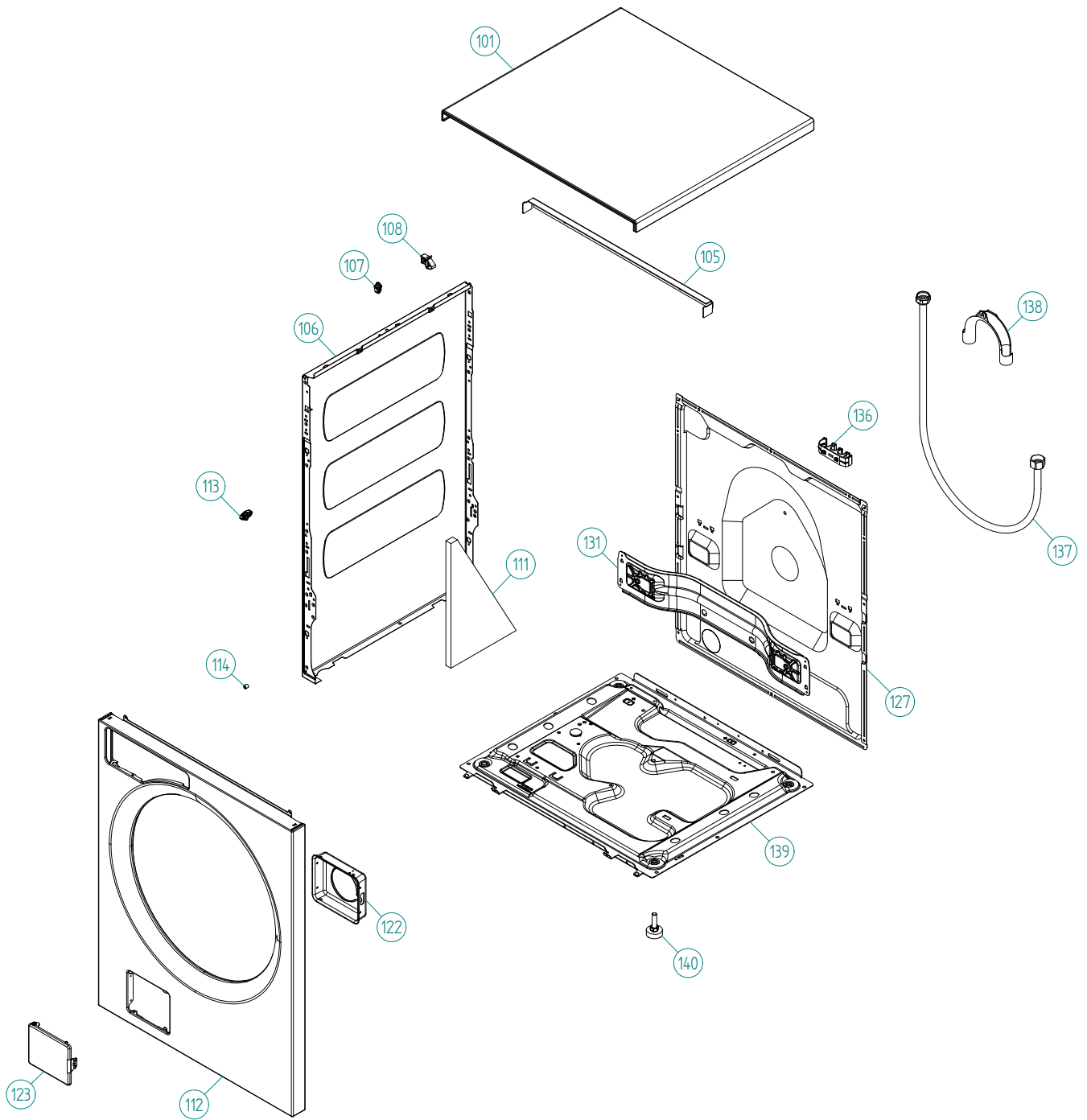

## Outer Casing

### ASKO, W6424 US - white (WM70.1)

Pos	Spare part No.	Description	Qty	Comment
101	8061817-0	Top Cover Wht WMD	1 Pc's	
101-a	8902362	Screw 20 Torx Self Tapping	3 Pc's	
101-b	8901413	Lock Washer laundry tops	2 Pc's	
105	8064198	Support Beam	1 Pc's	
105-a	8064255	Sponge Rubber Strip 2X8 L=272	1 Pc's	
106	8801496-0	KIT SIDE PLATE WASHER WHITE	1 Pc's	
106	8801174-0	Side Panel Washer 600s	2 Pc's	
107	8061763	Clip Front Plate 600700s	2 Pc's	
108	8061916	CABLE HOLDER WMD20	2 Pc's	
111	8064017	Insulation	1 Pc's	
112	8080117-0	FRONT WITHOUT DOOR COMPL.	1 Pc's	
112-a	8902362	Screw 20 Torx Self Tapping	2 Pc's	
112-b	8900327	Screw 20 Torx Self Tapping	2 Pc's	
113	8080197	PLASTIC BRACKET FRONT PLATE	2 Pc's	
114	8064222	Guide Front Plate	2 Pc's	
114-a	8900327	Screw 20 Torx Self Tapping	2 Pc's	
122	8061785	PUMP GUARD WM20	1 Pc's	
123	8061657-0	Door Out Pup W600s	1 Pc's	
127	8801466	REAR PANEL WM20/60/70	1 Pc's	
127-b	8902362	Screw 20 Torx Self Tapping	11 Pc's	
131	8088291	BEAM TRANSPORT BRACE WM70	1 Pc's	
131-a	8902362	SCREW RTK ST 4,2X9,5 FZB WAX.	4 Pc's	
133	8090105	TRANSPORTATION INSERT	3 Pc's	
134	8088277	SCREW M10X65 TT FZB	3 Pc's	
136	8065773	HOSE FRAME REAR COVER WM	2 Pc's	
137	8056950	Fill Hose Pex WM	1 Pc's	
138	8088270	HOSE HOLDER SIDEPLATE	2 Pc's	
138	8050805	GOOSE NECK for DRAIN HOSE	1 Pc's	
138-a	8002263	Cable Strip	1 Pc's	
139	8061618	BASE PAN WMD20	1 Pc's	
140	8059334	Leveling Leg Comp WMD 20	4 Pc's	

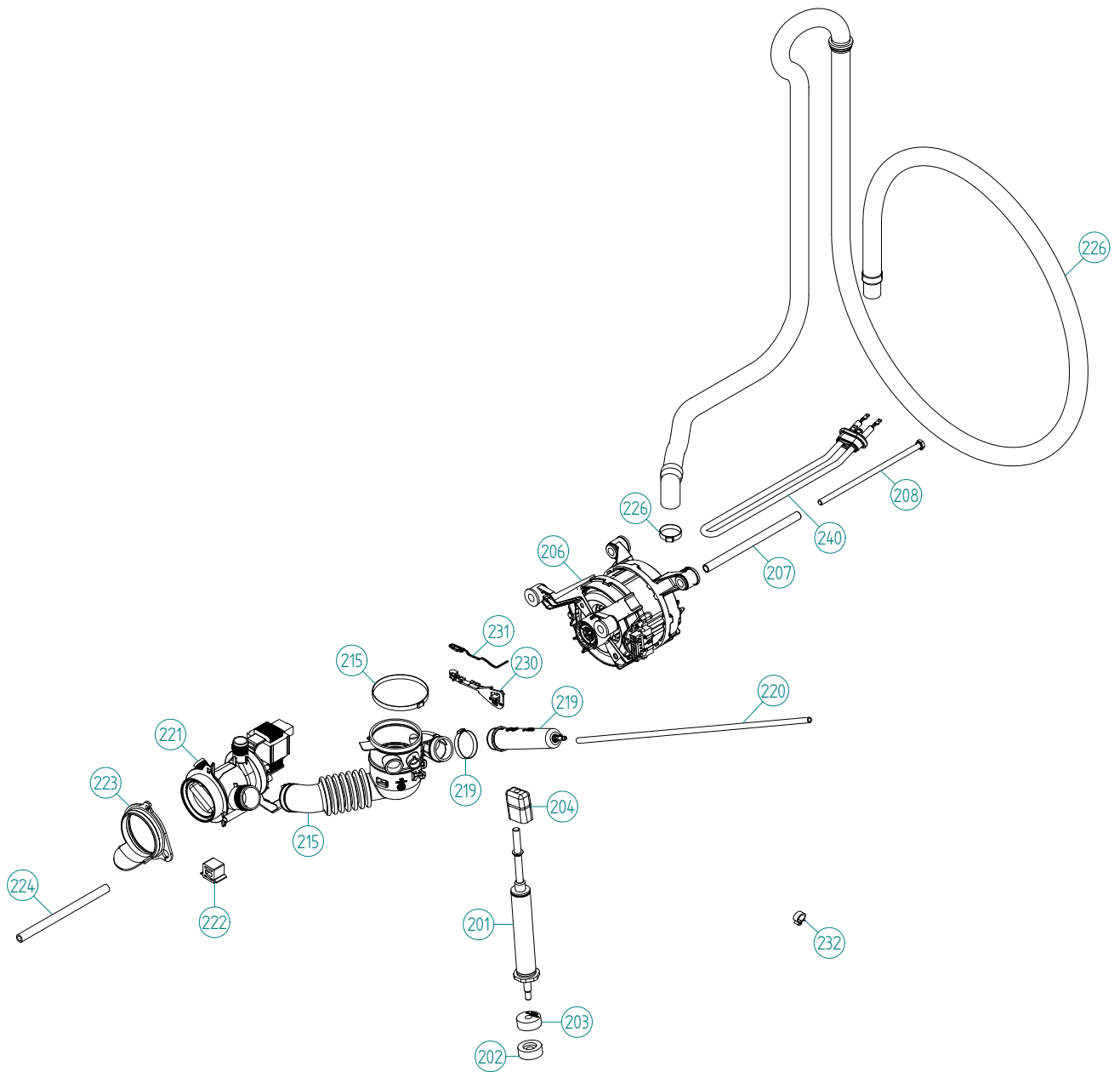

## Lower session

### ASKO, W6424 US - white (WM70.1)

Pos	Spare part No.	Description	Qty	Comment
201	8801454	SPRINGLEG KIT WM70	1 Pc's	
202	8088443	RUBBER BUFFER SPRING LEG FEMA.	4 Pc's	
203	8088444	RUBBER BUFFER SPRING LEG MALE	4 Pc's	
204	8088445	RUBBER DAMPER SPRINGLEG	4 Pc's	
206	8088099	MOTOR 60HZ UL4	1 Pc's	
207	8058261	Spacer Tube Motor 05 WM	2 Pc's	
208	8063591	Screw	2 Pc's	
215	8061681	Bellows Hose Outlet Pump	1 Pc's	
215-a	8063262	HOSE CLIP 80.0-708	1 Pc's	
215-b	8056471	Hose Clips	1 Pc's	
215-c	8084609	HOSE CLIP 39.6	1 Pc's	
215-c	8084609	HOSE CLIP 38,1	1 Pc's	
219	8061924	Pressure Chamber	1 Pc's	
219-c	8084609	HOSE CLIP 39.6	1 Pc's	
220	8082882	RUBBER HOSE 4,3X7,3X610	1 Pc's	
221	8801264	Drain Pump w/clamps	1 Pc's	
221-a	8801186	Seal Pump Insert	1 Pc's	
221-b	8801297	Pump insert	1 Pc's	
222	8061649	Rubber Buffer Drain Pump WM20	2 Pc's	
223	8061796	Rubber Ring Drain Pump WM20	1 Pc's	
224	8061725	Drain Hose WM20	1 Pc's	
224-a	8052731	HOSE CLIP 14,8	1 Pc's	
226	8061998	Outlet Hose WM20	1 Pc's	
226-a	8056491	HOSE CLIP 30.1-708	1 Pc's	
230	8801474	HOLDER THERMISTOR	1 Pc's	
230	8801474	THERMISTOR COMPL. W. HOLDER	1 Pc's	
231	8801474	THERMISTOR COMPL. W. HOLDER	1 Pc's	
231	8076102	THERMISTOR Repl.by 8801474	1 Pc's	
232	8061976	Cable Holder W600	2 Pc's	
240	8061706	HEATING ELEMENT 2000W 230V UL4	1 Pc's	

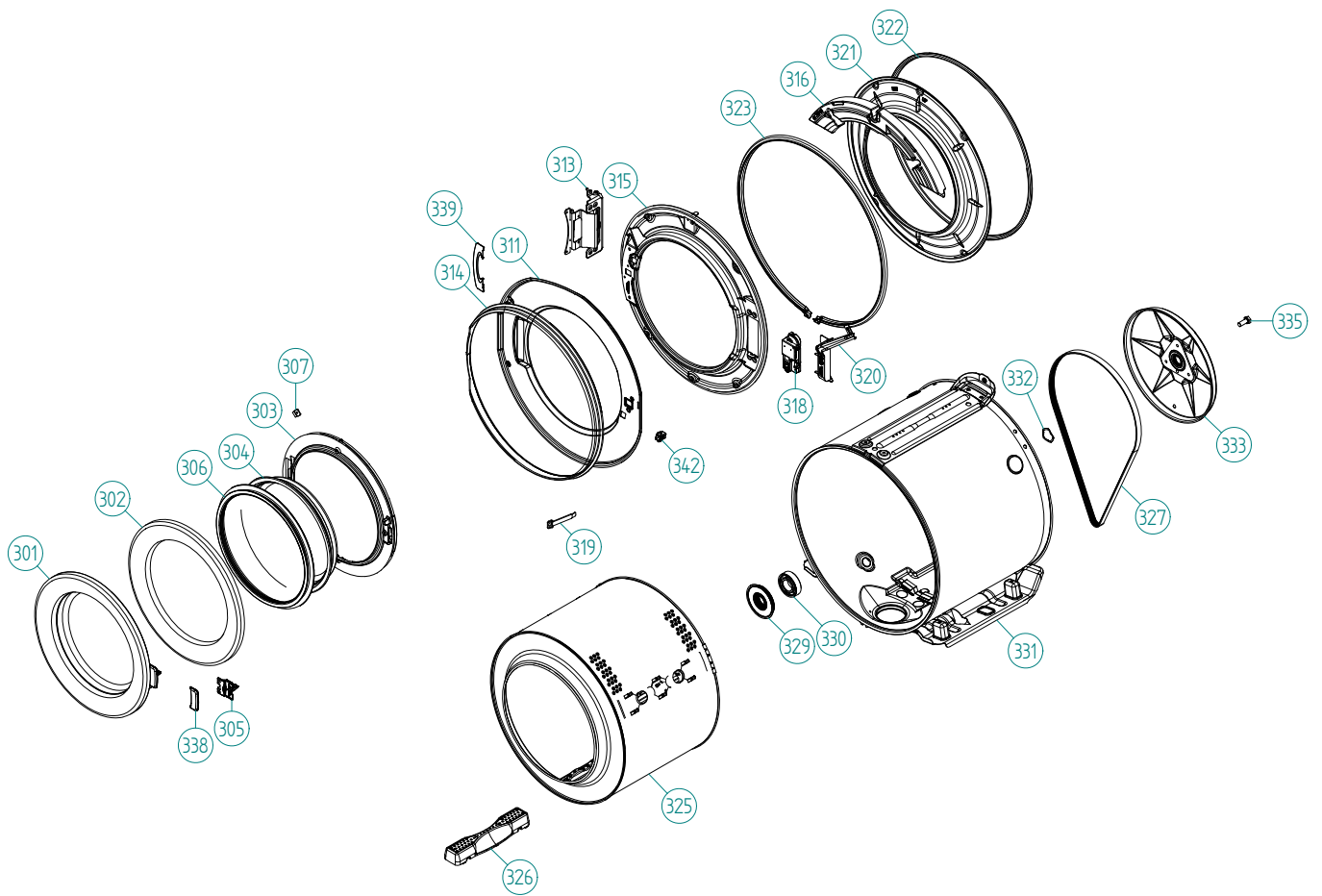

## Cylinder and related parts

ASKO, W6424 US - white (WM70.1)

Pos	Spare part No.	Description	Qty	Comment
301	8081875-85	FRONT DOOR COMPL.	1 Pc's	
302	8076548-85	FRAME FRONTDOOR OUTER PART UL4	1 Pc's	
303	8076547-49	FRAME FRONT DOOR INNER PART	1 Pc's	
304	8061685	Front Glass	1 Pc's	
305	8078973	LOCK HOOK UL4	1 Pc's	
306	8081128	SEALING FRONT DOOR WM60 UL4	1 Pc's	
307	8801321	KIT SECURING PLATE FRONT GLASS	1 Pc's	
311	8076560-0	COVER PLATE OUTER WHITE	1 Pc's	
313	8079471	HINGE COMPL.	1 Pc's	
313-a	8079877	SCREW MFT 8.8 M5X10 FZB	4 Pc's	
313-b	8901097	Screw Terminal	2 Pc's	
314	8076561-49	GAP SEALING	1 Pc's	
315	8081693	COVER PLATE INNER WM70	1 Pc's	
316	8076563	Balance Weight 5.1 KG	2 Pc's	
316-a	8901135	SCREW	4 Pc's	
318	8079873	DOOR LOCK	1 Pc's	
318-a	8902087	Screw Plastic Housing 20 Torx	2 Pc's	
319	8076566	EMERGENCY OPENER DOOR LOCK	1 Pc's	
320	8079959-UL	DOOR LOCK COVER	1 Pc's	
321	8081689	FRONT GABLE CONTAINER WM70	1 Pc's	
322	8081696	SEALING STRIP FRONT GABLE WM70	1 Pc's	
323	8081695-P	TENSIONRING WM70	1 Pc's	
325	8081676-P	DRUM Repl.by 8092250-P WM70	1 Pc's	
325	8092250-P	DRUM D480 COMPL. WM70	1 Pc's	
326	8090348	DRUM PADDLE WM70	3 Pc's	
326	8081678	DRUM PADDLE WM70	3 Pc's	
327	8081649	DRIVE BELT J5 1225	1 Pc's	
329	8801276	Kit Sealing Cassette	1 Pc's	
330	8056314	Bearing Comp WM Rear Panel	2 Pc's	
331	8801455	CONTAINER COMPL. WM70 1 EL.	1 Pc's	
332	8056810	Wave Washer WM	1 Pc's	
333	8056376	Pulley for Drum WM	1 Pc's	
335	8901052	Screw	1 Pc's	
338	8078975-85	COVER LOCK HOOK	1 Pc's	
339	8079283-0	HINGE COVER	1 Pc's	
342	8089887	GUIDE-2 GLASS DOOR	1 Pc's	

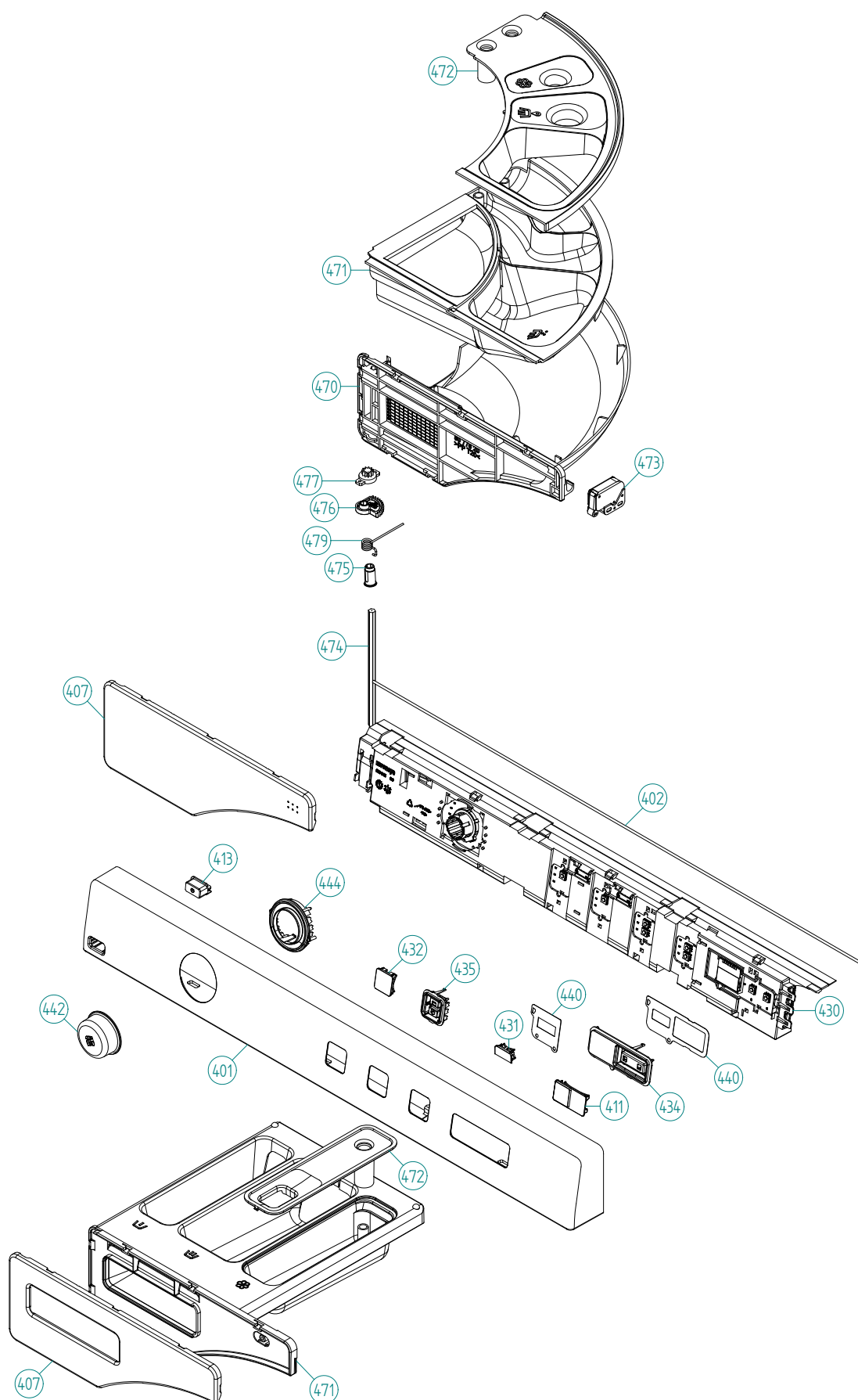



## Control Panel

### ASKO, W6424 US - white (WM70.1)

Pos	Spare part No.	Description	Qty	Comment
401	8088876-0-UL	PANEL ASKO W6424 US	1 Pc's	
402	8079749	Rubber Seal-Cntrl Panel to Brd	1 Pc's	
407	8076072-0	LID DETERGENT DISPENSER	1 Pc's	
407	8081672-0	LID DETERGENT DISP. W. HOLE	1 Pc's	
411	8083799-0	PUSHBUT. START/STOP PRINTED WM	1 Pc's	
413	8081710-0	PUSHBU. MAINSWITCH WMD60.2 UL4	1 Pc's	
430	8088614	CONTROL UNIT WM70.1 B (DISP.)	1 Pc's	
431	8083234-0	PUSHBUTT. OPTION 2 WMD60.1 UL4	2 Pc's	
432	8083233-0	PUSHBUTTON OPTION 1 WMD60.1	2 Pc's	
434	8083238	LENS START STOP DISP. WMD60.1	1 Pc's	
435	8083241	LENS OPTION WMD60.1	3 Pc's	
440	8088564	DECOR PLATE WMD60.1	1 Pc's	
442	8801433-0	KNOB COMPL. WMD60.1 WHITE	1 Pc's	
444	8083482	LENS JOGDIAL WMD60.1	1 Pc's	
460	8076204	CABLE SET MOTOR WM UL4	1 Pc's	
470	8077620	HOLDER DETERGENT COMPARTMENT	1 Pc's	
471	8077619	DETERGENT COMPARTMENT	1 Pc's	
471	8081664	DETERGENT COMPARTMENT	1 Pc's	
472	8081665	SIPHON Liq Softner Pull Compartment	1 Pc's	
472	8077142	SIPHON Liq DET Swing Compartment	1 Pc's	
473	8078925	PUSH LOCKING	1 Pc's	
474	8077621	SHAFT DETERGENT COMPARTMENT	1 Pc's	
475	8076159	BUSHING DETERGENT COMPARTMENT	3 Pc's	
476	8076189	GEAR RING DETERGENT CONTAINER	1 Pc's	
477	8078924	DAMPER DETERGENT COMPARTMENT	1 Pc's	
479	8077622	TORSION SPRING	1 Pc's	

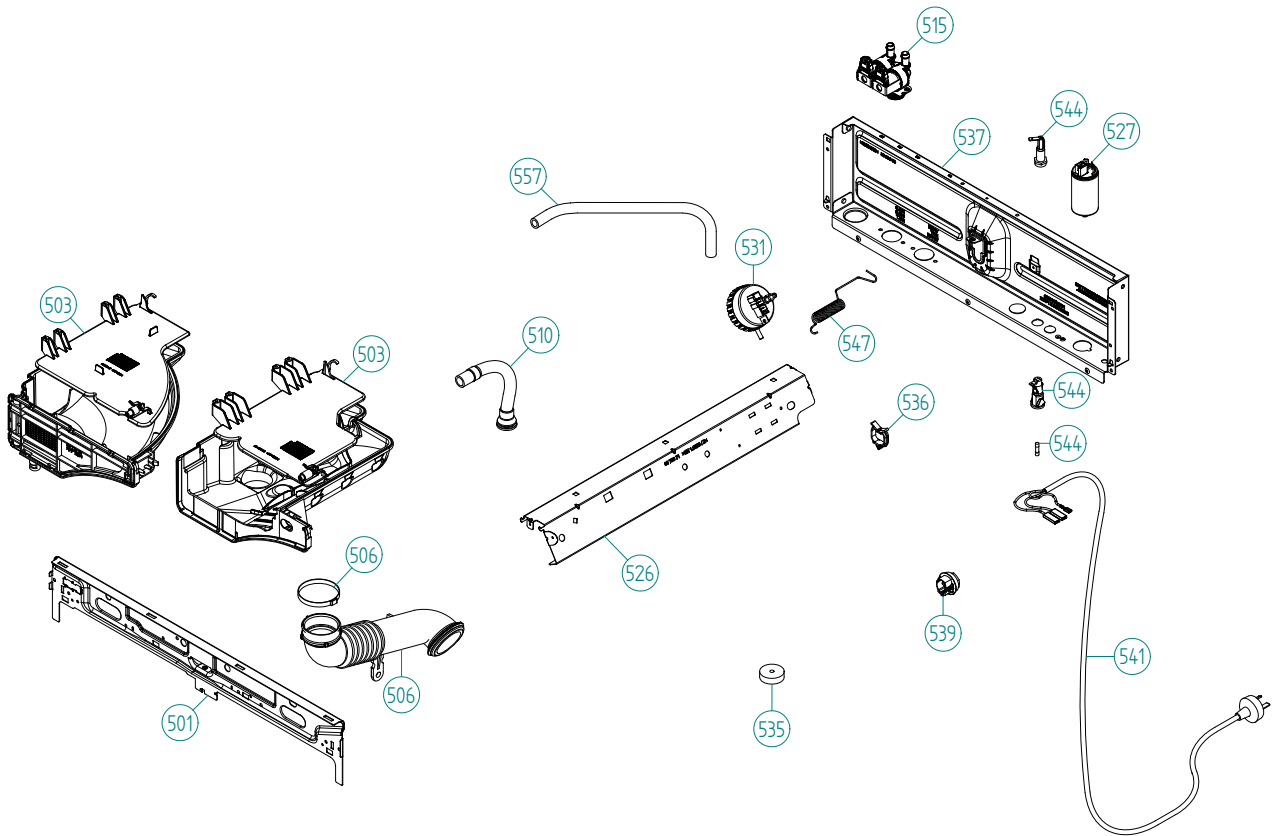

## Upper session

### ASKO, W6424 US - white (WM70.1)

Pos	Spare part No.	Description	Qty	Comment
501	8076029	FRONTBEAM	1 Pc's	
501-a	8902362	Screw 20 Torx Self Tapping	2 Pc's	
501-b	8901413	Lock Washer laundry tops	2 Pc's	
503	8081808	DETERGENT COMP. COMPL. UL4	1 Pc's	
503	8081666	DETERGENT COMP. COMPL. UL4	1 Pc's	
503-a	8901970	Screw	1 Pc's	
503-b	8902072	SCREW PT KB40X10 WN1442 GALV	1 Pc's	
506	8064692	BELLOW HOSE INLET UL4	1 Pc's	
506	8081670	BELLOW HOSE INLET WM60 UL4	1 Pc's	
506-a	8063607	HOSE CLIP 57,5	1 Pc's	
510	8061736	Ventilation Hose WM20	1 Pc's	
510-a	8052730	HOSE CLIP 21,0	1 Pc's	
515	8083880	INLET VALVE 2-WAY	1 Pc's	
515-a	8901097	Screw Terminal	2 Pc's	
526	8078971	UNIT FOR ELECTR. COMP.	1 Pc's	
527	8076202	EMC-FILTER WITH INDUCTOR	1 Pc's	
527-a	8901155	Nut	1 Pc's	
527-b	8901419	Lock Washer	1 Pc's	
529	8079716	CABLE SET N AP LL WM UL4	1 Pc's	
529	8079717	CABLE SET EL WM UL4	1 Pc's	
529	8082568	CABLE SET P WM UL4	1 Pc's	
529	8084487	GROUND CABLE WM UL4	1 Pc's	
529	8084188	CABLE SET IV WM60.1 UL4	1 Pc's	
531	8089765	LEVEL SWITCH WM70.1	1 Pc's	
535	8061997	Ground Level Switch Hose WM20	2 Pc's	
536	8061975	Cable Holder	1 Pc's	
537	8089748	CROSS BEAM	1 Pc's	
537-a	8900327	Screw 20 Torx Self Tapping	5 Pc's	
539	8006948	Grommet	1 Pc's	
541	8064210	PWR Cord w/flat pin sleeves	1 Pc's	
544	8801354	FUSE HOLDER GREY 15A US/CA	2 Pc's	
544-a	8801354	BK/MDA15 Fuse All laundry	2 Pc's	
544-b	8801354	Hub Fuse Holder	2 Pc's	
544-c	8801354	Fuse Holder Laundry	2 Pc's	
547	8089723	BALANCING SPRING	2 Pc's	
557	8058502	RUBBER HOSE 10X15X360 UL1	2 Pc's	

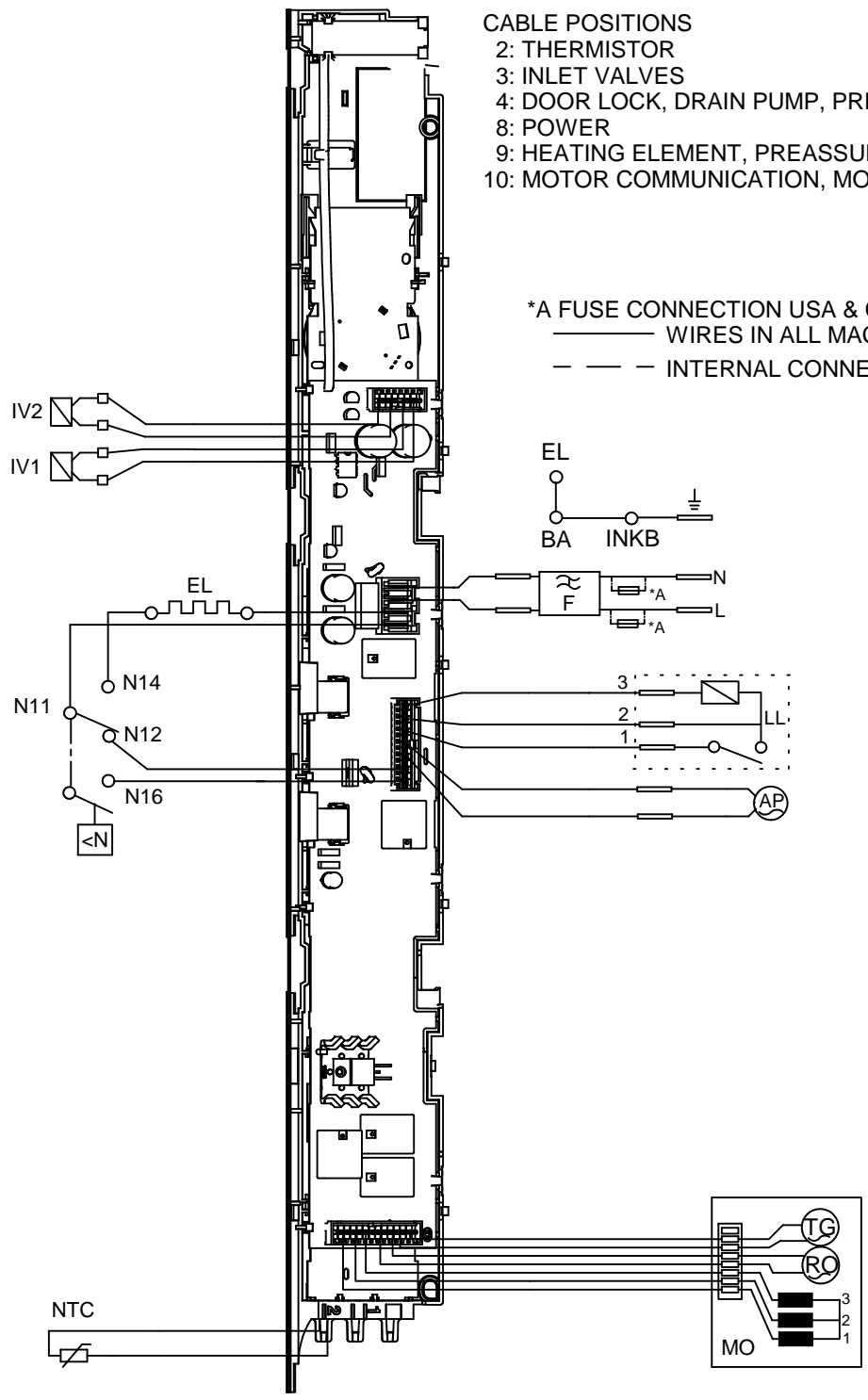

- CABLE POSITIONS**  
 2: THERMISTOR  
 3: INLET VALVES  
 4: DOOR LOCK, DRAIN PUMP, PREASSURE SWITCH  
 8: POWER  
 9: HEATING ELEMENT, PREASSURE SWITCH  
 10: MOTOR COMMUNICATION, MOTOR POWER

\*A FUSE CONNECTION USA & CANADA  
 ——— WIRES IN ALL MACHINES  
 - - - INTERNAL CONNECTION

RESISTANCES AT ROOM TEMPERATURE (CA. 20°C/68°F)  
 VALUES WITHIN +/-10% ARE REGARDED AS NORMAL COMPONENT

F: RADIO INTERFERENCE SUPPRESSION FILTER	680K Ohm	
EL: HEATING ELEMENT	25 Ohm	
AP: DRAIN PUMP 50 Hz	144 Ohm	
AP: DRAIN PUMP 60 Hz	76 Ohm	
LL: DOOR LOCK, 1-2	122 Ohm	
NTC: THERMISTOR	6.1 - 3.8 K Ohm	
IV 1: INLET VALVE 1	3.7 K Ohm	
IV 2: INLET VALVE 2	3.7 K Ohm	
MO: MOTOR, 1-3	3,7±7% Ohm	
	1-2	3,6±7% Ohm
	2-3	3,6±7% Ohm

- MCU: MOTOR CONTROL UNIT  
 N: PRESSURE SWITCH  
 TS: PRESSURE SENSOR  
 TG: TACHO GENERATOR  
 BA: CONTAINER  
 INKB: INCOMING GROUND



**TOTAL RESET**

- TURN OFF POWER (S1)
- WAIT FOR AT LEAST 5 SEC
- HOLD DOOR OPENING (S11)
- TURN ON POWER (S1)

**SERVICE MENU**

- TURN OFF POWER (S1)
- WAIT FOR AT LEAST 5 SEC
- HOLD START/STOP (S10)
- TURN ON POWER (S1)
- PRESS START/STOP (S10) 5 TIMES TO ENTER SERVICE MENU

- PRESS DOOR OPENING (S11) TO CHANGE MENU STEP
- ROTATE DIAL TO CHANGE IN STEP
- PRESSING START/STOP (S10) STORES AND EXITS SERVICE MENU

2010-10-27

CIRCUIT DIAGRAM WM70.1

80 886 21-02

This document must not be copied without our written permission, and the contents thereof must not be imparted to a third party nor be used for any unauthorized purpose. Contravention will be prosecuted. Asko Appliances AB