

Spare Parts Catalogue

ASKO Washing Machines \ ASKO 600 Series
Type: WM44US
Model: W620 US white

Prod. No: 10762010
January 16th 2013

ASKO Appliances Inc.

4001 E Plano Parkway #1004001 E Plano Parkway #100
Plano, Texas 75074

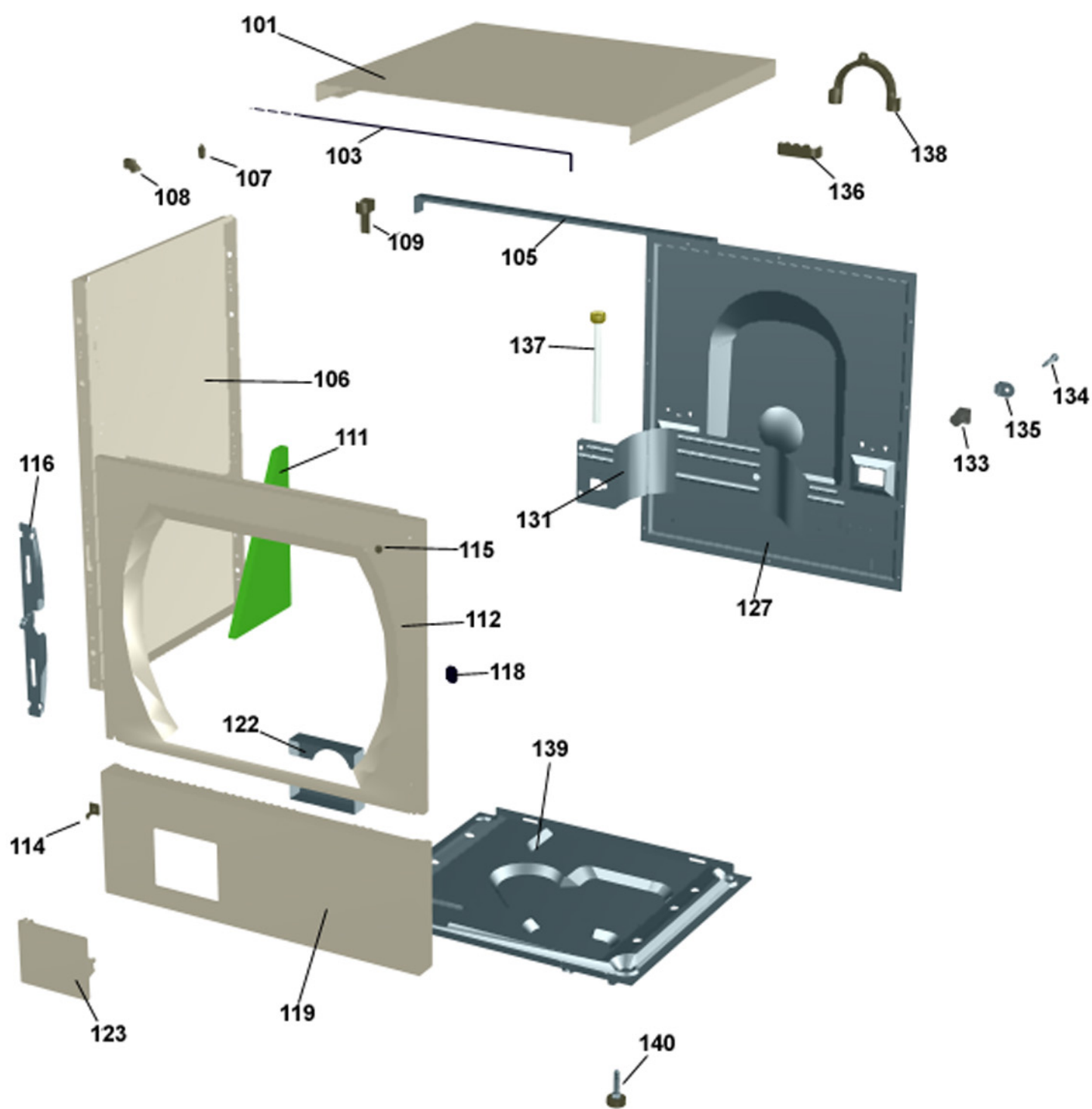

Outer casing

ASKO, W620 US - white (WM44US)

Pos	Spare part No.	Description	Qty	Comment
101	8061817-0	Top Cover Wht WMD	1 Pc's	
101-a	8902362	Screw 20 Torx Self Tapping	3 Pc's	
101-b	8901413	Lock Washer laundry tops	2 Pc's	
103	8064062	Top Cover Strip	1 Pc's	
105	8064198	Support Beam	1 Pc's	
106	8801174-0	Side Panel Washer 600s	1 Pc's	
107	8061763	Clip Front Plate 600700s	2 Pc's	
108	8061916	CABLE HOLDER WMD20	3 Pc's	
109	8061713	HOLDER HOSE/SIDE PLATE WMD20	2 Pc's	
111	8064017	Insulation	1 Pc's	
112	8061732-0	FRONT PLATE WHITE	1 Pc's	
112-a	8900327	Screw 20 Torx Self Tapping	4 Pc's	
112-b	8901413	Lock Washer laundry tops	2 Pc's	
114	8064177	Hook Lower Pane	2 Pc's	
114-a	8902362	Screw 20 Torx Self Tapping	2 Pc's	
115	8061741	RUBBER BUFFER FRONT DOOR	2 Pc's	
116	8061744	HINGE BEARING	2 Pc's	
116-a	8901097	Screw Terminal	6 Pc's	
118	8061745	RUBBER BUFFER HINGE	2 Pc's	
119	8064294-0	Lower Cover Must order 2 8	1 Pc's	
119-a	8900327	Screw 20 Torx Self Tapping	2 Pc's	
119-b	8901413	Lock Washer laundry tops	2 Pc's	
122	8061785	PUMP GUARD WM20	1 Pc's	
123	8061657-0	Door Out Pup W600s	1 Pc's	
127	8801466	REAR PANEL WM20/60/70	1 Pc's	
127-b	8902362	Screw 20 Torx Self Tapping	11 Pc's	
131	8061693	Cross Beam Rear 600	1 Pc's	
131-a	8902362	Screw 20 Torx Self Tapping	4 Pc's	
131-b	8901413	Lock Washer laundry tops	1 Pc's	
133	8064206-UL	GrommetShipping Support 600s	3 Pc's	
134	8901037	Screw bufo	3 Pc's	
135	8061767	Locking Clip Shipping 600s	3 Pc's	
136	8065773	HOSE FRAME REAR COVER WM	2 Pc's	
137	8056950	Fill Hose Pex WM	1 Pc's	
138	8050805	GOOSE NECK for DRAIN HOSE	1 Pc's	
138-a	8002263	Cable Strip	1 Pc's	
139	8061618	BASE PAN WMD20	1 Pc's	
140	8059334	Leveling Leg Comp WMD 20	4 Pc's	

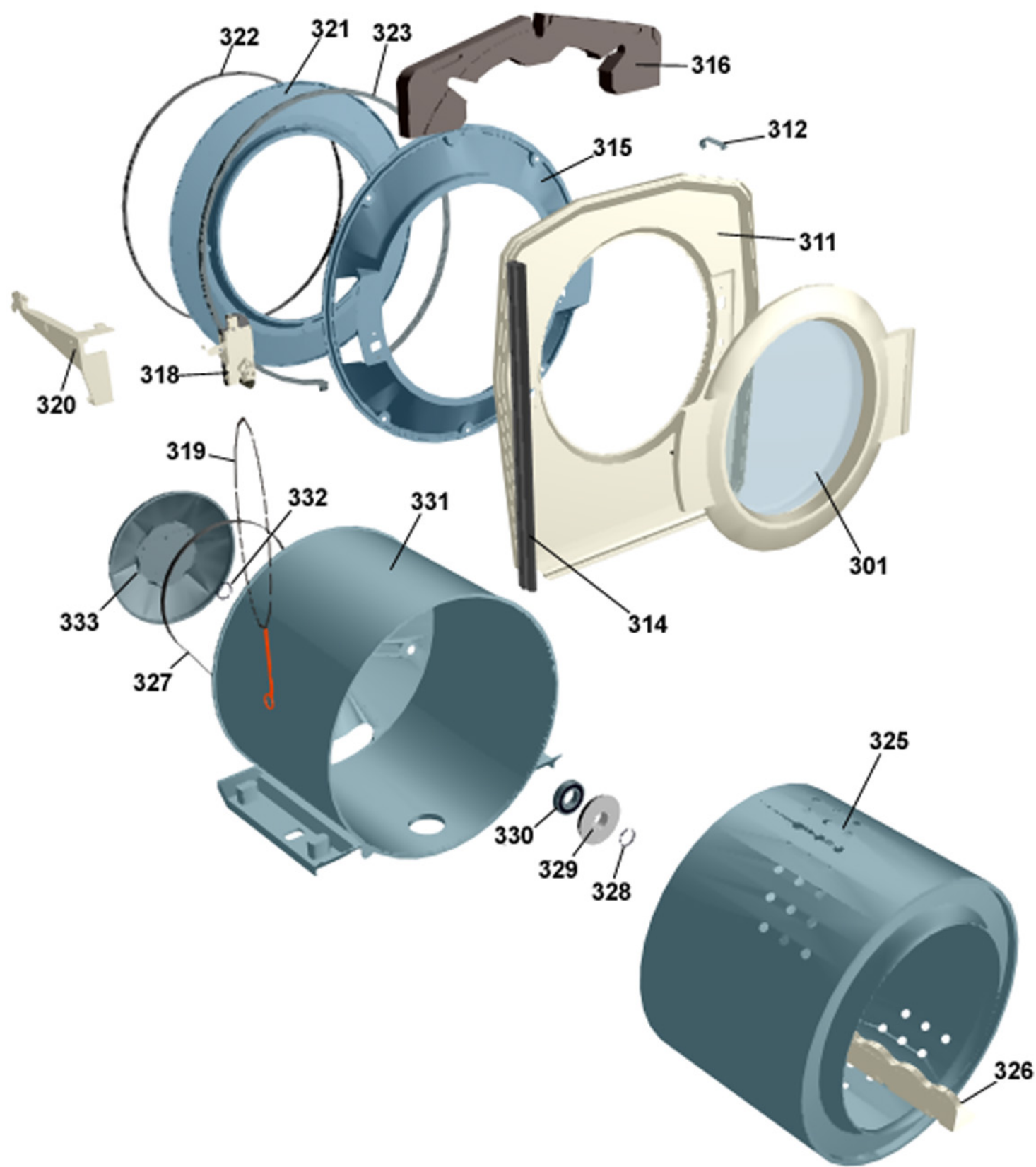

Cylinder and related parts

ASKO, W620 US - white (WM44US)

Pos	Spare part No.	Description	Qty	Comment
301	8064906-0	Front Door Compl Wht WM20/21	1 Pc's	
302	8061651-0	Front Door Outer Frame	1 Pc's	
303	8061652-0	Front Door Frame Inner	1 Pc's	
304	8061685	Included with POS 301	1 Pc's	
305	8061798	Lock Hook Door 600s	1 Pc's	
306	8064025	Seal front door WM20/21	1 Pc's	
307	8801321	Securing Plate	4 Pc's	
308	8061686-0	Hinge Front Door White	1 Pc's	
308-a	8901969	SCREW MRT-TT 5x12 FZB T20	2 Pc's	
309	8061687	Shaft for Hinge WM 20	1 Pc's	
311	8061671-0	Cover Plate Outer White	1 Pc's	
312	8061879	Tension Spring	4 Pc's	
314	8061616	Gap Sealing Side WM 20	2 Pc's	
315	8061670	COVER PLATE INNER	1 Pc's	
316	8061678	NLA-Damper Weight	2 Pc's	
316-a	8901135	SCREW	3 Pc's	
318	8061679	Door Lock Comp W600s	1 Pc's	
318-a	8902087	Screw Plastic Housing 20 Torx	2 Pc's	
319	8801305	EMERGENCY OPENING COMPL.	1 Pc's	
320	8061680	CONTACT GUARD DOOR LOCK	1 Pc's	
321	8065043	Front Panel Tub	1 Pc's	
322	8061889	Seal Strip Tub 600s	1 Pc's	
323	8061669	TENSION RING WM20	1 Pc's	
325	8801277	NLA-Cylinder w/Sealing Kit	1 Pc's	
326	8061604	Drum Paddle	3 Pc's	
327	8061682	Drive Belt W600 Series	1 Pc's	
328	8058497	ORing 600s Drum Shaft WM	1 Pc's	
329	8801276	Kit Sealing Cassette	1 Pc's	
330	8056314	Bearing Comp WM Rear Panel	2 Pc's	
331	8801259	CONTAINER COMPL.WM20 CAST IRON	1 Pc's	
332	8056810	Wave Washer WM	1 Pc's	
333	8056376	Pulley for Drum WM	1 Pc's	
334	8057209	WASHER 42X10X5	1 Pc's	
335	8901052	Screw	1 Pc's	

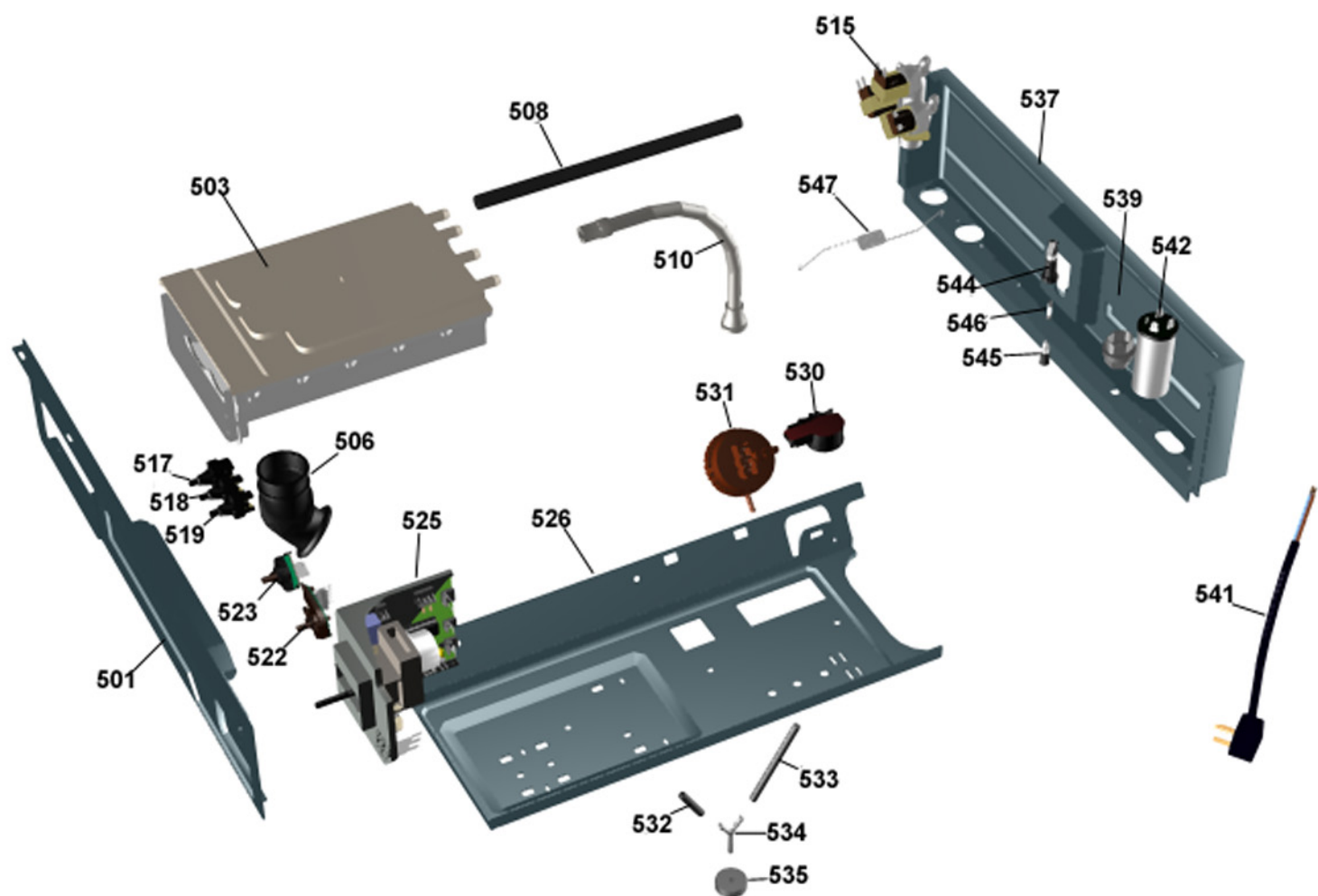

Upper session

ASKO, W620 US - white (WM44US)

Pos	Spare part No.	Description	Qty	Comment
501	8061690	Front Beam 600/700 Series	1 Pc's	
501-a	8902362	Screw 20 Torx Self Tapping	2 Pc's	
501-b	8901413	Lock Washer laundry tops	2 Pc's	
501-c	8902087	Screw Plastic Housing 20 Torx	2 Pc's	
503	8061661	Container Det Disp 600s	1 Pc's	
503-a	8901970	Screw	2 Pc's	
503-b	8902072	SCREW PT KB40X10 WN1442 GALV	1 Pc's	
503-c	8056656	Cable Tie	3 Pc's	
506	8061628	BELLOWS HOSE INLET WM20	1 Pc's	
506	8064692	BELLOW HOSE INLET UL4	1 Pc's	
506-a	8063607	HOSE CLIP 57,5	1 Pc's	
508	8061702	Rubber Hose	3 Pc's	
510	8061736	Ventilation Hose WM20	1 Pc's	
510-a	8052730	HOSE CLIP 21,0	1 Pc's	
515	8061757	Fill Valve 3way 600	1 Pc's	
515-a	8901097	Screw Terminal	2 Pc's	
517	8061875	Switch ON/OFF WM20	1 Pc's	
518	8063719	Push Button SW 1 CLOS MOM UL4	1 Pc's	
519	8063717	Push Button Switch 1 Closing	3 Pc's	
522	8061665	Temp Switch W600 620	1 Pc's	
523	8061728	Rotary Selector WM20	1 Pc's	
525	8064200	Timer FHP WM600/620	1 Pc's	
526	8061692	Bracket Elec Comp WM 20	1 Pc's	
526-a	8902362	Screw 20 Torx Self Tapping	2 Pc's	
526-b	8900327	Screw 20 Torx Self Tapping	1 Pc's	
529	8086800-1	Basic Harness WM4433	1 Pc's	
530	8061664	Level Sensor WM	1 Pc's	
531	8064275	Level Switch WM21 UL4	1 Pc's	
532	8003641	Rubber Hose	1 Pc's	
533	7382985	Rubber Hose	1 Pc's	
534	8051843	Y Pipe Water Level SW WM	1 Pc's	
535	8061997	Ground Level Switch Hose WM20	2 Pc's	
536	8061975	Cable Holder	2 Pc's	
537	8061694	CROSS BEAM Repl.by 8801477	1 Pc's	
537-a	8900327	Screw 20 Torx Self Tapping	4 Pc's	
539	8006948	Grommet	1 Pc's	
541	8064210	PWR Cord w/flat pin sleeves	1 Pc's	
542	8058558	RFI 05/06 WM	1 Pc's	
542-a	8901155	Nut	1 Pc's	
542-b	8901419	Lock Washer	1 Pc's	
544	8801354	Fuse Holder Assembly	2 Pc's	For units produced before wk 34 2002
545	8801354	Fuse Holder Assembly	2 Pc's	For units produced before wk 34 2002
546	8058140	Fuse	1 Pc's	
547	8061923	Balancing Spring WM 20	2 Pc's	

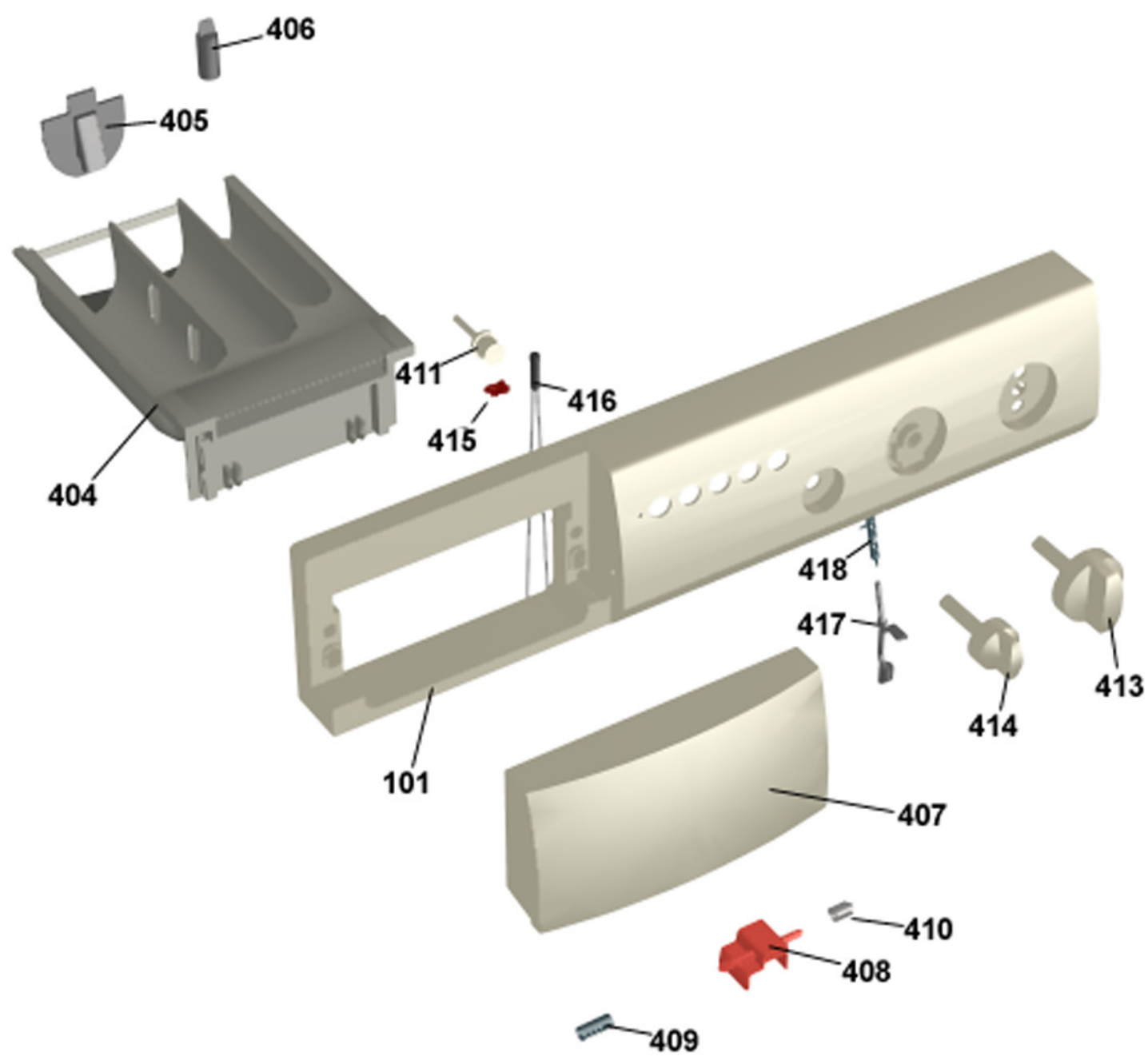

Control panel

ASKO, W620 US - white (WM44US)

Pos	Spare part No.	Description	Qty	Comment
401	8063839-0-UL	Panel w/Handle W620	1 Pc's	
401-a	8901591	Clip/Panel 600700s	4 Pc's	
403	8063366-49	Plate Prog Info WM33/44	1 Pc's	
403	8063374-49	Plate Prog Info WM33/44	1 Pc's	
403	8063382-49	PLATE PROGINFO WM33/44 US	1 Pc's	
404	8061630	Detergent Comp WM20	1 Pc's	
405	8061633	Siphon Divider Liq Det 600s	1 Pc's	
406	8061634	Siphon Fabric softener WM20	1 Pc's	
408	8061621-34	Safety Catch Det Com W600s	1 Pc's	
409	8061622	Spring Safety Catch WM20	1 Pc's	
410	8064010	Spacing sleeve	1 Pc's	
411	8061711-0	Push Buttons TNM33/44/11/22	5 Pc's	
413	8061892-0	Knob Temp/Timer w/clips WMD20	2 Pc's	
414	8061775-0	Knob Spin Speed W/Clips WM 20	1 Pc's	
415	8061822	Decor Lens	1 Pc's	
416	8060478	Ind Lamp 600s WM	1 Pc's	
417	8061709-0	Safety Catch Temp	1 Pc's	
418	8063974	Torsion Spring Safety Catch	1 Pc's	
490	8063858	INSTR GENERAL WM20 US/CA	1 Pc's	

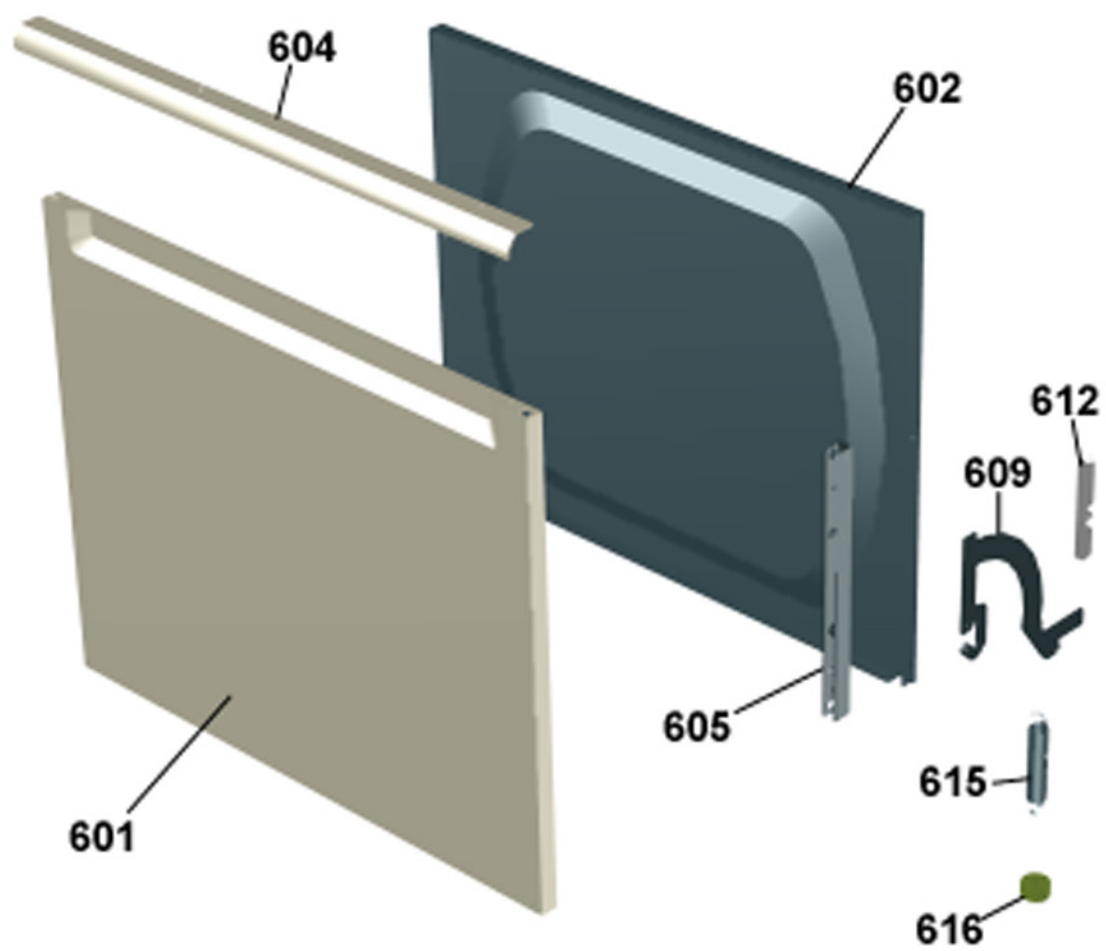

Outer door

ASKO, W620 US - white (WM44US)

Pos	Spare part No.	Description	Qty	Comment
601	8061733-0	Outer Door WMD20	1 Pc's	
602	8061734	Door Inner Part WM 20	1 Pc's	
604	8061656-0	Handle Front Door WM 20 WHT	1 Pc's	
606	8061764	Reinforcement Hinge WM 20	1 Pc's	
606-a	8901969	SCREW MRT-TT 5x12 FZB T20	4 Pc's	
606-b	8901097	Screw Terminal	4 Pc's	
609	8061906	Hinge Electric WM 20	2 Pc's	
609-a	8901192	Locking Nut WM 03/05	2 Pc's	
609-b	8901004	Screw	2 Pc's	
609-c	7382628	Nylon Washer	2 Pc's	
612	8061777-0	Guide Hinge WM 20 White	2 Pc's	
615	8061742	Tension Spring Hinge WM 20	1 Pc's	
616	8061909	Glide Sleeve Tension Spring	1 Pc's	

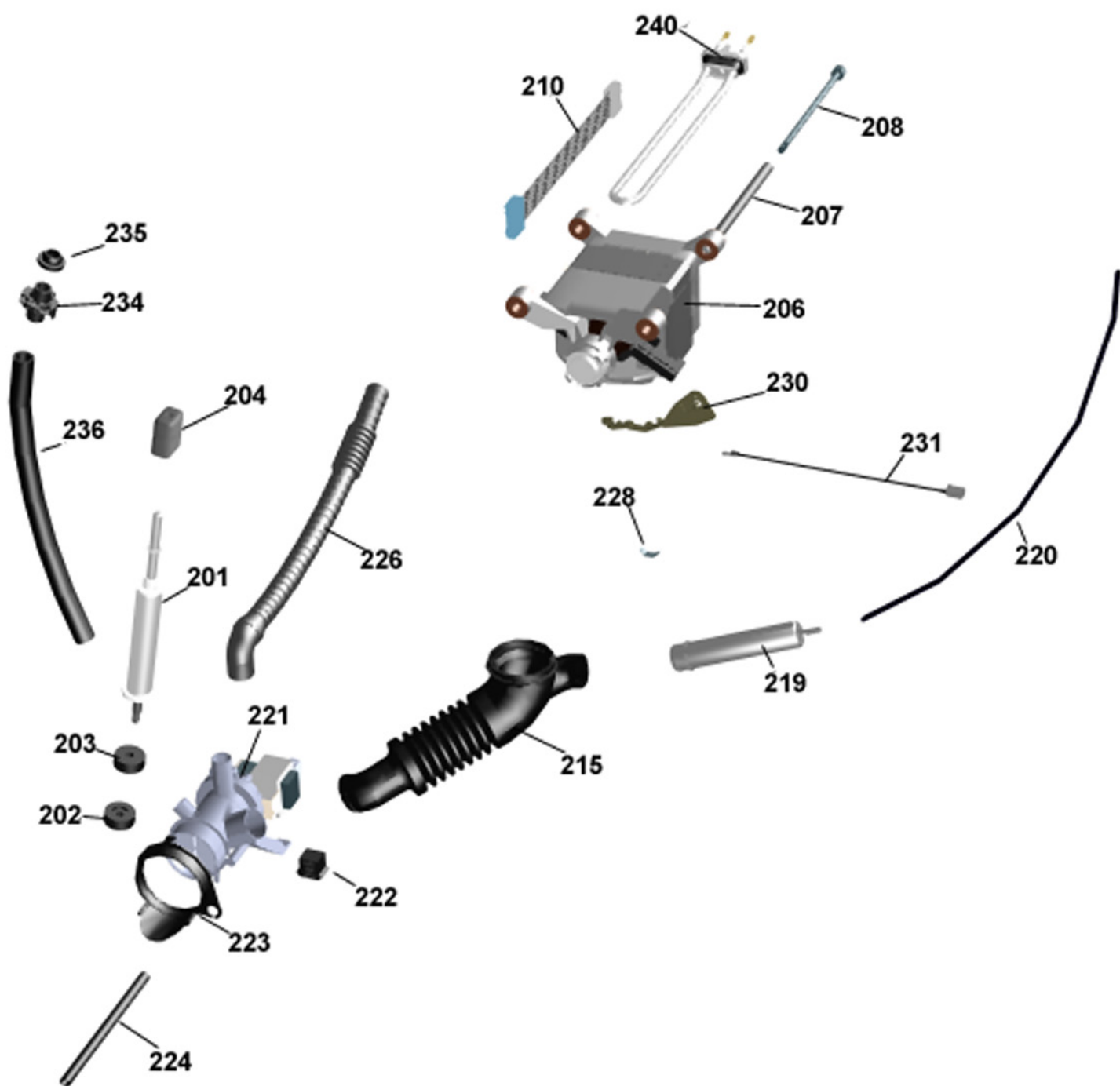

Lower session

ASKO, W620 US - white (WM44US)

Pos	Spare part No.	Description	Qty	Comment
201	8801171	Spring Leg Kit W600s-Set of 4	1 Pc's	
202	8055796	RUBBER BUFFER SPRING LEG	4 Pc's	
203	8055797	RUBBER BUFFER SPRING LEG	4 Pc's	
204	8061668	Rubber Damper Spring Leg	4 Pc's	
206	8063733	Motor FHP WM33/44	1 Pc's	
206-a	8901155	Nut	2 Pc's	
206-b	8901337	Washer	1 Pc's	
207	8058261	Spacer Tube Motor 05 WM	2 Pc's	
208	8063591	Screw	2 Pc's	
210	8086801	Cable Set WM44/33	1 Pc's	
215	8801516	Bellows Hose Outlet Pump w/Clamps	1 Pc's	
215-a	8063262	HOSE CLIP 80.0-708	1 Pc's	
215-b	8056471	Hose Clips	1 Pc's	
215-c	8084609	HOSE CLIP 39.6	1 Pc's	
219	8061924	Pressure Chamber	1 Pc's	
219-c	8084609	HOSE CLIP 39.6	1 Pc's	
220	7382670	Rubber Hose	1 Pc's	
221	8801264	Drain Pump w/clamps	1 Pc's	
221-a	8801186	Seal Pump Insert	1 Pc's	
221-b	8801297	Pump insert	1 Pc's	
222	8061649	Rubber Buffer Drain Pump WM20	2 Pc's	
223	8061796	Rubber Ring Drain Pump WM20	1 Pc's	
224	8061725	Drain Hose WM20	1 Pc's	
224-a	8052731	HOSE CLIP 14,8	1 Pc's	
226	8061998	Outlet Hose WM20	1 Pc's	
226-a	8056491	HOSE CLIP 30.1-708	1 Pc's	
228	33700183	Terminal	1 Pc's	
228-a	8901097	Screw Terminal	1 Pc's	
228-b	8901413	Lock Washer laundry tops	1 Pc's	
230	8061738	Thermistor Holder WM20	1 Pc's	
231	8061663	Thermistor W600's	1 Pc's	
232	8061976	Cable Holder W600	2 Pc's	
234	8061674	Recirculation Stub	1 Pc's	
235	8061673	Grommet Recirculation Stub	1 Pc's	
236	8063721	Hose recirculation WM20	1 Pc's	
236-a	8054196	Clamp	2 Pc's	
240	8061706	HEATING ELEMENT 2000W 230V UL4	1 Pc's	

KOMPLETTSCHEMA 80 617 12

SUUWm2011_Tryckunderlag/Kopplingschema/8061751_KWM33_44/061751_KWM33_44-05.dft, ssov, 2000-10-13 14:28:00

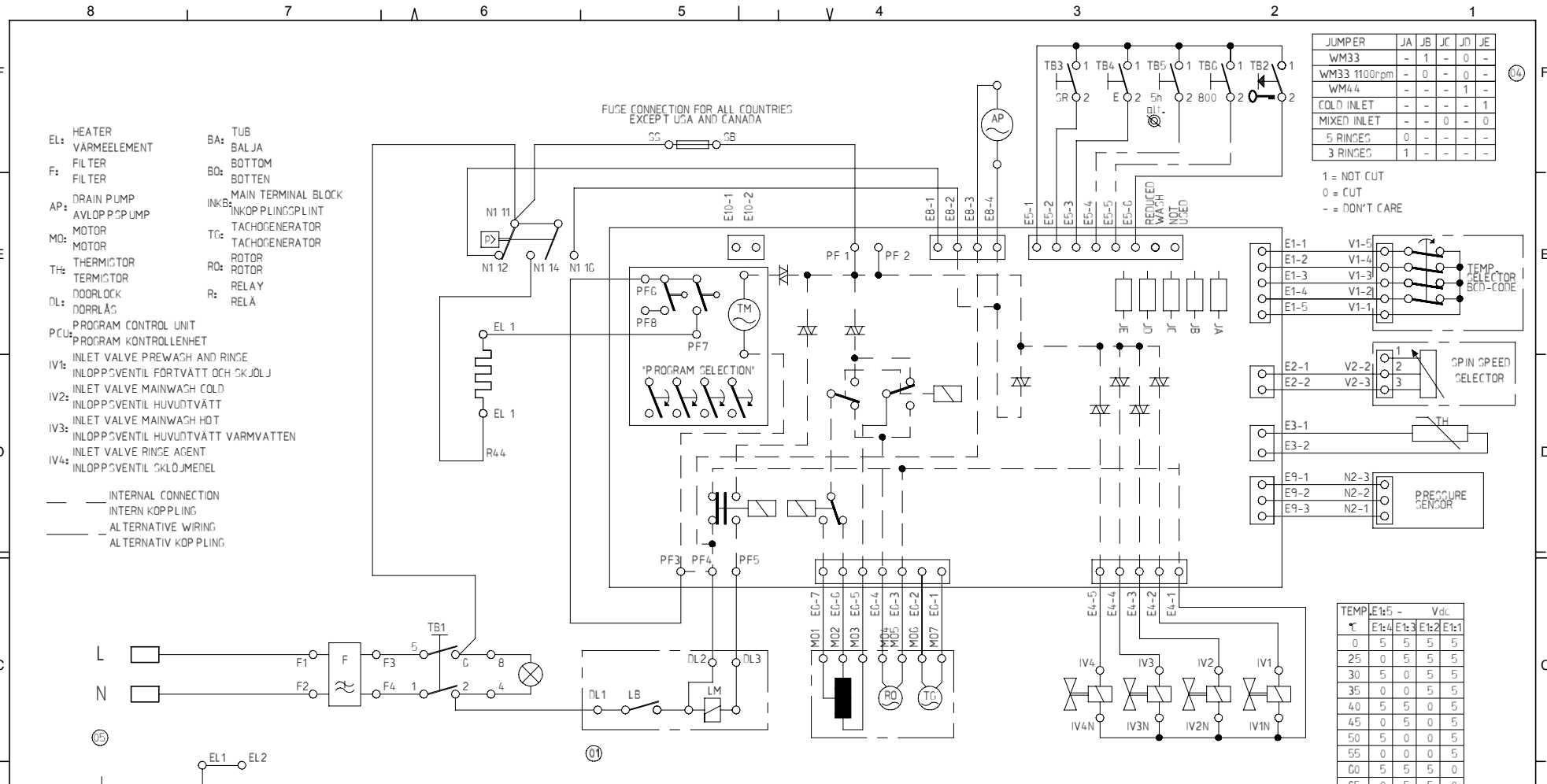

- EL: HEATER
VARMEELEMENT
- F: FILTER
FILTER
- AP: DRAIN PUMP
AVLOPPSPUMP
- M0: MOTOR
MOTOR
- TH: THERMISTOR
TERMISTOR
- DL: DOORLOCK
DÖRRÄS
- PCU: PROGRAM CONTROL UNIT
PROGRAM KONTROLLENHET
- IV1: INLET VALVE PREWASH AND RINSE
INLOPPSVENTIL FÖRTVÄTT OCH SKJÖLJ
- IV2: INLET VALVE MAINWASH COLD
INLOPPSVENTIL HUVUDTVÄTT
- IV3: INLET VALVE MAINWASH HOT
INLOPPSVENTIL HUVUDTVÄTT VARMVATTEN
- IV4: INLET VALVE RINSE AGENT
INLOPPSVENTIL SKJÖLJMEDEL
- BA: TUB
BALJA
- BO: BOTTOM
BOTTEN
- INKB: MAIN TERMINAL BLOCK
INKOPPLINGPLINT
- TC: TACHOGENERATOR
TACHOGENERATOR
- RO: ROTOR
RÖTOR
- R: RELAY
RELA
- INTERNAL CONNECTION
INTERN KOPPLING
- ALTERNATIVE WIRING
ALTERNATIV KOPPLING

JUMPER	JA	JB	JC	JN	JE
WM33	-	1	-	0	-
WM33 1100rpm	-	0	-	0	-
WM44	-	-	-	1	-
COLD INLET	-	-	-	-	1
MIXED INLET	-	-	0	-	0
5 RINGES	0	-	-	-	-
3 RINGES	1	-	-	-	-

1 = NOT CUT
0 = CUT
- = DON'T CARE

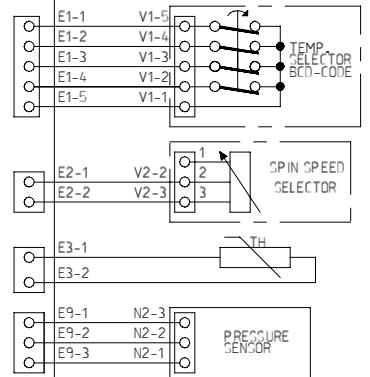

TEMP	E1:5	E1:4	E1:3	E1:2	E1:1
0	5	5	5	5	5
25	0	5	5	5	5
30	5	0	5	5	5
35	0	0	5	5	5
40	5	5	0	5	5
45	0	5	0	5	5
50	5	0	0	5	5
55	0	0	0	5	5
60	5	5	5	0	5
65	0	5	5	0	5
70	5	0	5	0	5
75	0	0	5	0	5
80	5	5	0	0	5
85	0	5	0	0	5
90	5	0	0	0	5
95	0	0	0	0	5

- E2:1 - E2:2 0 V (1200 RPM) - 4,5 Vdc (NO SPIN + NO DRAIN)
- E3:1 - E3:2 5 Vdc (THERMISTOR DISCONNECTED)
- E5:1 - E5:2 5 Vdc SWITCH OPEN 0 V SWITCH CLOSED
- E5:1 - E5:3 5 Vdc SWITCH OPEN 0 V SWITCH CLOSED
- E5:1 - E5:4 5 Vdc SWITCH OPEN 0 V SWITCH CLOSED
- E5:1 - E5:5 5 Vdc SWITCH OPEN 0 V SWITCH CLOSED
- E5:1 - E5:6 5 Vdc SWITCH OPEN 0 V SWITCH CLOSED
- E8:3 - E8:4 230 Vdc DRAIN PUMP ON
- E9:1 - E9:3 5 Vdc
- E9:1 - E9:2 0,5 Vdc AT ZERO WATER PRESSURE
- E4:1 - E4:2 230 Vdc IV1 ON
- E4:1 - E4:3 230 Vdc IV2 ON
- E4:1 - E4:4 230 Vdc IV3 ON
- E4:1 - E4:5 230 Vdc IV4 ON

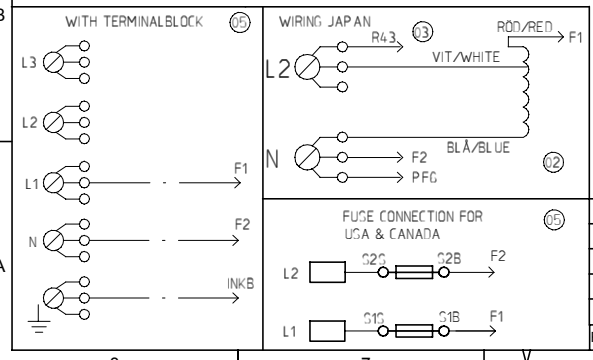

Rev ind	Revision	Appd	Year	Week
05	Drawing modified	SS	00	41
04	WM33 1100rpm added	PS	00	05
03	F43 changed to R43	PS	99	41
02	Wiring Japan added	PS	99	26
01	Doorlock number changed	PS	99	20

Pos.	Qty	Part No.	Name of item	Material
Material		Dens.Kg/dm3	Dimensions, Type, etc.	
Scale		Gen.tolerance		Description(ENG)
Designed by		Gen.tol.Angle		CIRCUIT DIAGRAM WM 33/44
Released by		Iss by Dept	Year	Week
		UT	98	07
		Description(SE)		KOPPLINGSSCHEMA WM 33/44
ASKO CYLINDA				80 617 51 05
Rev Ind	Replace	Project		8061751 rev.04

This document must not be copied without our written permission, and the contents may not be used for any unauthorized purpose. Askö Cylinda AB