



## Spare Parts Catalogue

ASKO Washing Machines \ ASKO Prof Series  
Type: WM70.C  
Model: WMC 64 P US Stainless

Prod. No: 107604901

February 4th 2013

**ASKO Appliances Inc.**

4001 E Plano Parkway #1004001 E Plano Parkway #100  
Plano, Texas 75074

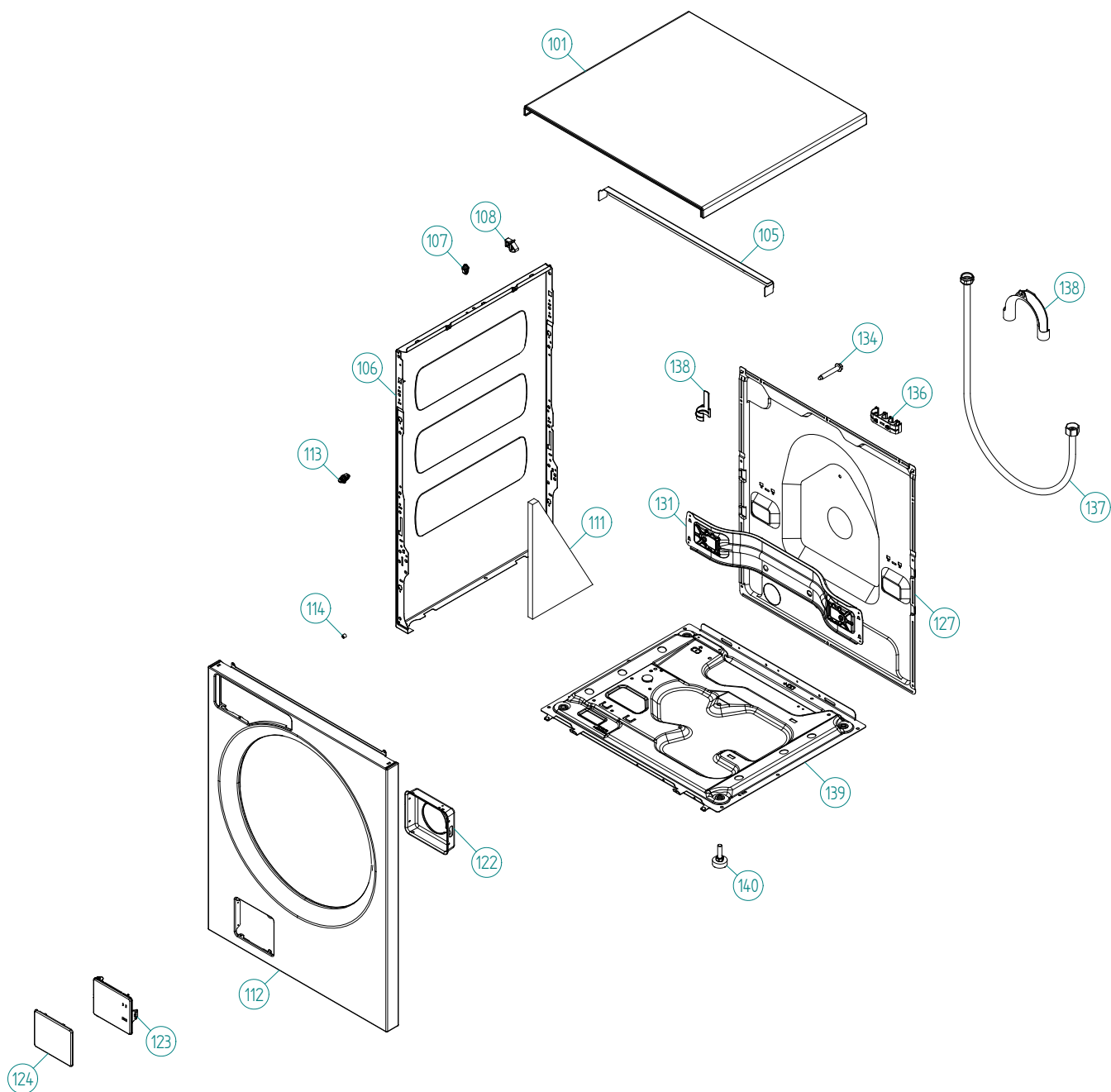

## Outer Casing

### ASKO, WMC 64 P US - Stainless (WM70.C)

Pos	Spare part No.	Description	Qty	Comment
101	8061817-91	TOP COVER FPR	1 Pc's	
101-a	8902362	Screw 20 Torx Self Tapping	3 Pc's	
101-b	8901413	Lock Washer laundry tops	2 Pc's	
105	8064198	Support Beam	1 Pc's	
105-a	8064255	Sponge Rubber Strip 2X8 L=272	1 Pc's	
106	8801496-81	KIT SIDE PLATE WASHER MET.GREY	1 Pc's	
106	8801174-81	Side WM50 titanium	2 Pc's	
107	8061763	Clip Front Plate 600700s	2 Pc's	
108	8061916	CABLE HOLDER WMD20	1 Pc's	
111	8064017	Insulation	1 Pc's	
112	8080117-91	FRONT WITHOUT DOOR COMPL.	1 Pc's	
113	8080197	PLASTIC BRACKET FRONT PLATE	2 Pc's	
114	8064222	Guide Front Plate	2 Pc's	
114-a	8900327	Screw 20 Torx Self Tapping	2 Pc's	
122	8061785	PUMP GUARD WM20	1 Pc's	
123	8076076-49	CARRIER LID DRAINAGE PUMP	1 Pc's	
124	8076071-91	LID DRAIN PUMP	1 Pc's	
127	8801466	REAR PANEL WM20/60/70	1 Pc's	
127-b	8902362	Screw 20 Torx Self Tapping	11 Pc's	
131	8088291	BEAM TRANSPORT BRACE WM70	1 Pc's	
134	8088277	SCREW M10X65 TT FZB	3 Pc's	
136	8065773	HOSE FRAME REAR COVER WM	2 Pc's	
137	8056950	Fill Hose Pex WM	2 Pc's	
138	8050805	GOOSE NECK for DRAIN HOSE	1 Pc's	
138	8088270	HOSE HOLDER SIDEPLATE	2 Pc's	
138-a	8002263	Cable Strip	1 Pc's	
139	8061618	BASE PAN WMD20	1 Pc's	
140	8059334	Leveling Leg Comp WMD 20	4 Pc's	

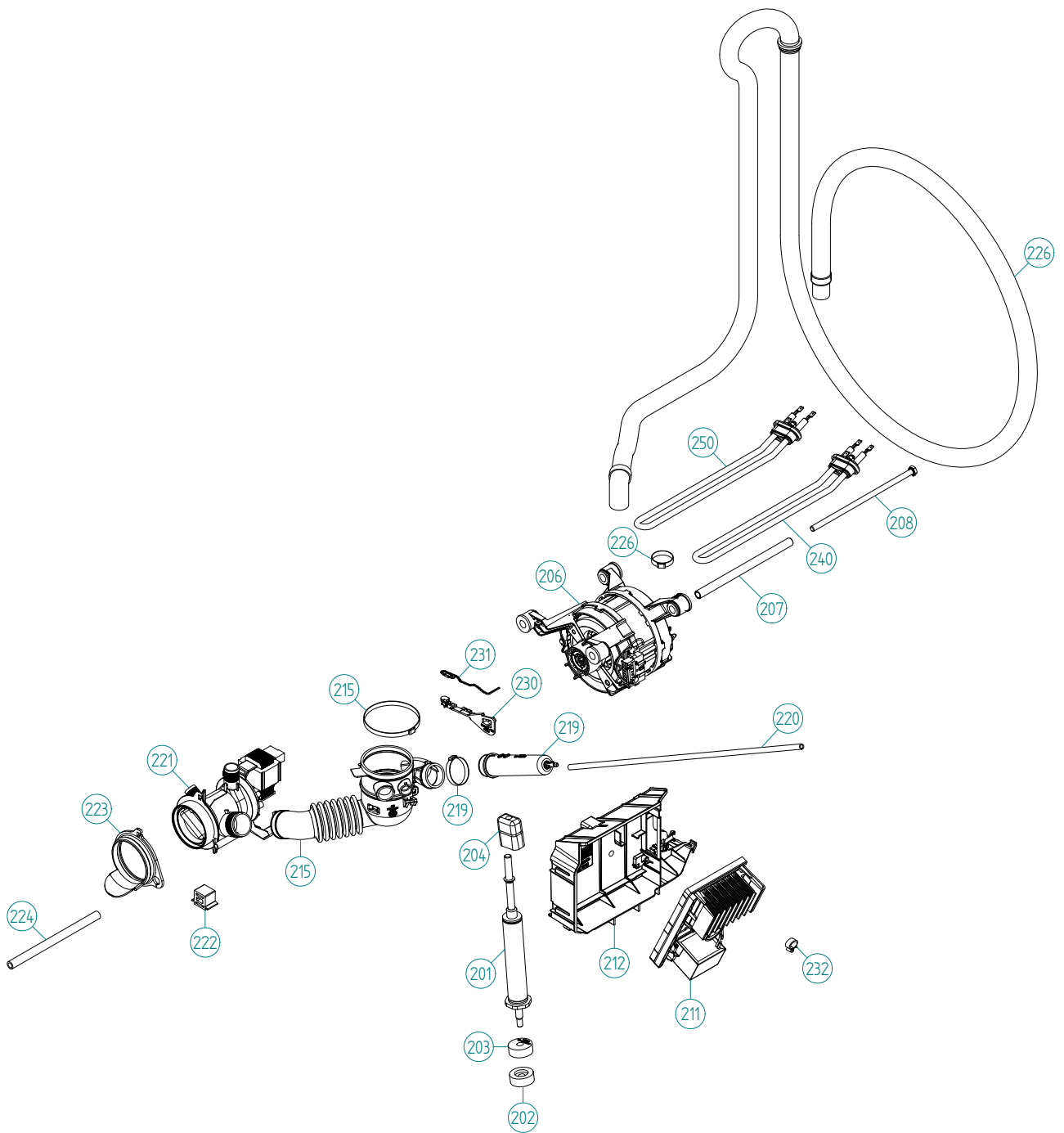

**Lower session****ASKO, WMC 64 P US - Stainless (WM70.C)**

<b>Pos</b>	<b>Spare part No.</b>	<b>Description</b>	<b>Qty</b>	<b>Comment</b>
201	8801454	SPRINGLEG KIT WM70	1 Pc's	
202	8088443	RUBBER BUFFER SPRING LEG FEMA.	4 Pc's	
203	8088444	RUBBER BUFFER SPRING LEG MALE	4 Pc's	
204	8088445	RUBBER DAMPER SPRINGLEG	4 Pc's	
206	8088644	MOTOR CIM WM70	1 Pc's	
207	8058261	Spacer Tube Motor 05 WM	2 Pc's	
208	8063591	Screw	2 Pc's	
211	8089672	MOTOR CONTROL UNIT CIM-A	1 Pc's	
211-a	8901097	Screw Terminal	1 Pc's	
211-b	8901322	Washer	1 Pc's	
212	8083420	HOLDER CONTROL UNIT(MOTOR) UL4	1 Pc's	
215	8801516	Bellows Hose Outlet Pump w/Clamps	1 Pc's	
215-a	8063262	HOSE CLIP 80.0-708	1 Pc's	
215-b	8056471	Hose Clips	1 Pc's	
215-c	8084609	HOSE CLIP 39.6	1 Pc's	
215-c	8084609	HOSE CLIP 38,1	1 Pc's	
219	8061924	Pressure Chamber	1 Pc's	
219-c	8084609	HOSE CLIP 39.6	1 Pc's	
220	8080831	RUBBER HOSE 4,3X7,3X527	1 Pc's	
221	8801264	Drain Pump w/clamps	1 Pc's	
221-a	8801186	Seal Pump Insert	1 Pc's	
221-b	8801297	Pump insert	1 Pc's	
222	8061649	Rubber Buffer Drain Pump WM20	2 Pc's	
223	8061796	Rubber Ring Drain Pump WM20	1 Pc's	
224	8061725	Drain Hose WM20	1 Pc's	
224-a	8052731	HOSE CLIP 14,8	1 Pc's	
226	8061998	Outlet Hose WM20	1 Pc's	
226-a	8056491	HOSE CLIP 30.1-708	1 Pc's	
231	8801474	THERMISTOR COMPL. W. HOLDER	1 Pc's	
232	8061976	Cable Holder W600	2 Pc's	
240	8061703	Heating Element Commercial	1 Pc's	
250	8061704	Heating Element Commercial R	1 Pc's	

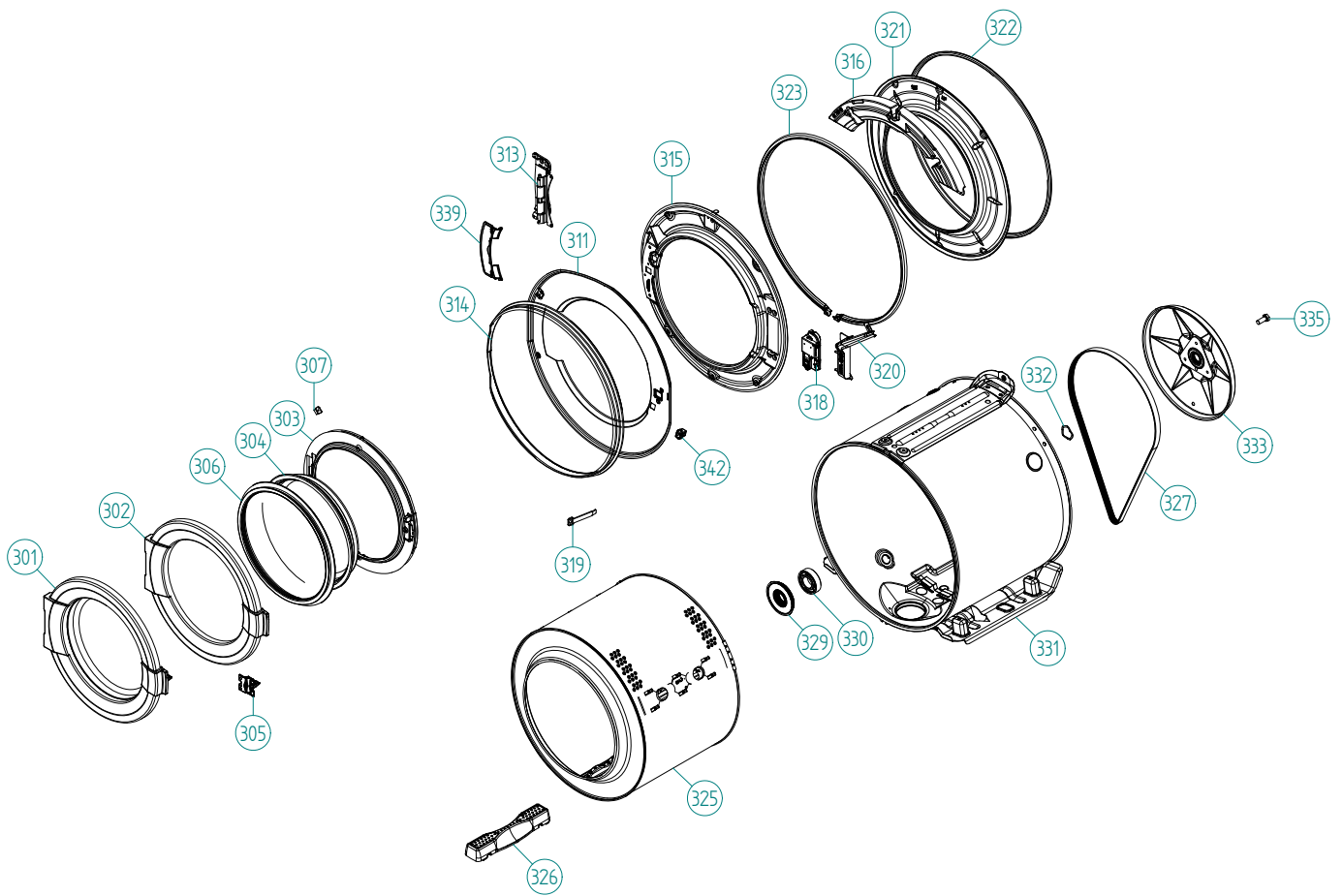

## Cylinder and related parts

### ASKO, WMC 64 P US - Stainless (WM70.C)

Pos	Spare part No.	Description	Qty	Comment
301	8082933-81	FRONT DOOR COMPL WM60	1 Pc's	
302	8082933-81	FRAME FRONT DOOR OUTER PART	1 Pc's	
303	8082933-81	FRAME FRONT DOOR INNER PART	1 Pc's	
304	8061685	Included with POS 301	1 Pc's	
305	8078973	LOCK HOOK UL4	1 Pc's	
306	8081128	SEALING FRONT DOOR WM60 UL4	1 Pc's	
307	8801321	KIT SECURING PLATE FRONT GLASS	1 Pc's	
311	8082563-29	COVER PLATE OUTER WM60.C	1 Pc's	
313	8082561	HINGE WM60.C COMPL.	1 Pc's	
313-a	8901097	Screw Terminal	2 Pc's	
314	8076561-81	GAP SEALING	1 Pc's	
315	8081693	COVER PLATE INNER WM70	1 Pc's	
316	8076563	Balance Weight 5.1 KG	2 Pc's	
316-a	8901135	SCREW	4 Pc's	
318	8079873	DOOR LOCK	1 Pc's	
318-a	8902087	Screw Plastic Housing 20 Torx	2 Pc's	
319	8076566	EMERGENCY OPENER DOOR LOCK	1 Pc's	
320	8079959-UL	DOOR LOCK COVER	1 Pc's	
321	8081689	FRONT GABLE CONTAINER WM70	1 Pc's	
322	8081696	SEALING STRIP FRONT GABLE WM70	1 Pc's	
323	8081695-P	TENSIONRING WM70	1 Pc's	
325	8092250-P	DRUM D480 COMPL. WM70	1 Pc's	
325	8081676-P	DRUM Repl.by 8092250-P WM70	1 Pc's	
326	8081678	DRUM PADDLE WM70	3 Pc's	
326	8090348	DRUM PADDLE WM70	3 Pc's	
327	8081649	DRIVE BELT J5 1225	1 Pc's	
329	8801276	Kit Sealing Cassette	1 Pc's	
330	8056314	Bearing Comp WM Rear Panel	2 Pc's	
331	8801456	CONTAINER COMPL. WM70 2 EL.	1 Pc's	
332	8056810	Wave Washer WM	1 Pc's	
333	8056376	Pulley for Drum WM	1 Pc's	
335	8901052	Screw	1 Pc's	
339	8083250-33	COVER HINGE WM60.C	1 Pc's	
342	8089887	GUIDE-2 GLASS DOOR	1 Pc's	

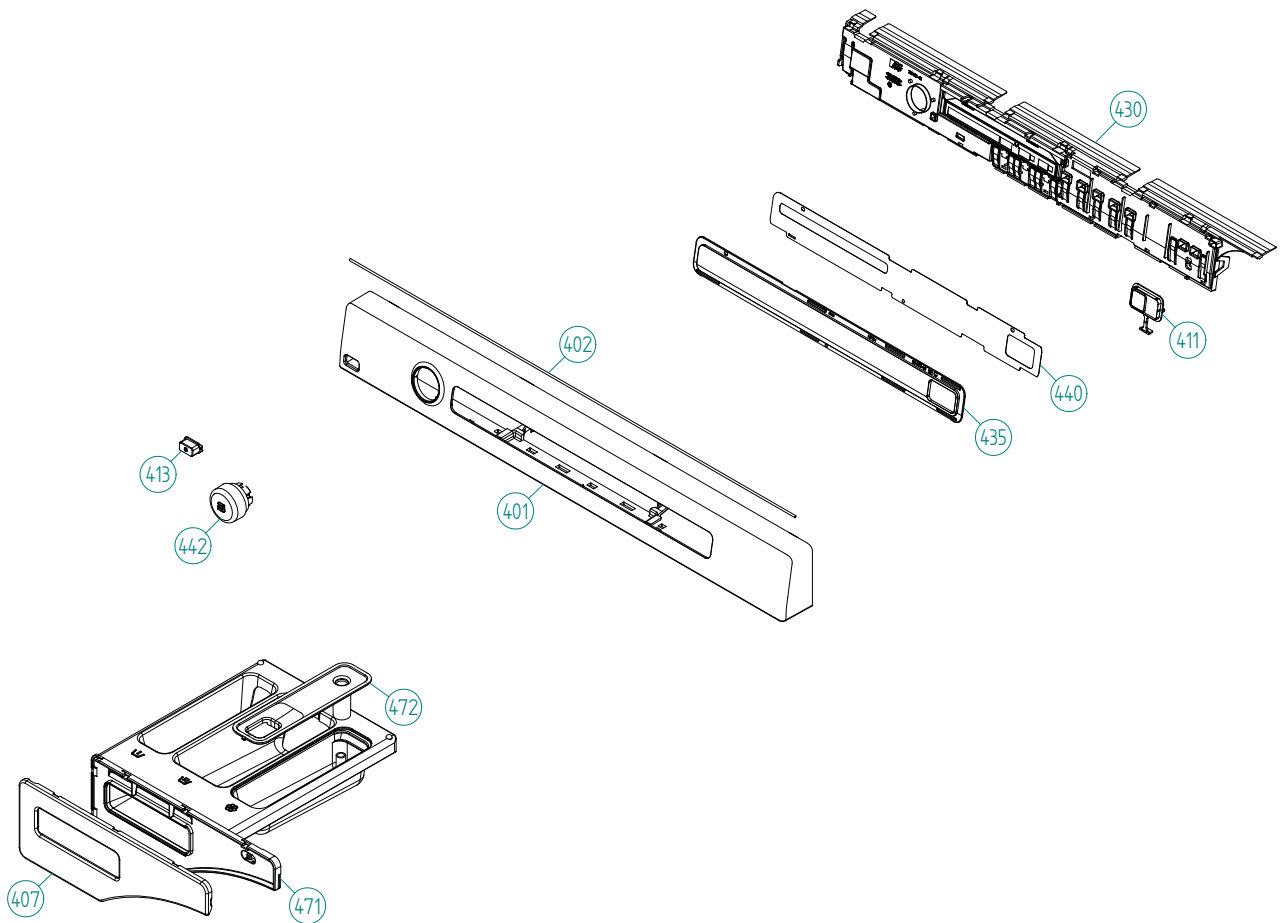



## Control Panel

### ASKO, WMC 64 P US - Stainless (WM70.C)

Pos	Spare part No.	Description	Qty	Comment
401	8089020-69-UL	PANEL ASKO PROFESSIONAL	1 Pc's	
402	8079749	Rubber Seal-Cntrl Panel to Brd	1 Pc's	
407	8081672-91	LID DETERGENT DISP. W. HOLE	1 Pc's	
411	8081748-69	PUSHBUT. START/STOP PRINTED WM	1 Pc's	
413	8081710-69	PUSHBU. MAINSWITCH WMD60.2 UL4	1 Pc's	
430	8088612	Control Unit WM70.C	1 Pc's	
435	8083316	LENS 0-OPTIONS WMD60.2	1 Pc's	
440	8083375-81	DECOR PLATE 0-OPTIONS WMD60.C	1 Pc's	
442	8081595-69-UL	KNOB ASKO WMD60.2 UL4	1 Pc's	
468	8076209	NLA-GROUND CHAIN WM UL4	1 Pc's	
469	8086440	CABLE SET COIN BOX	1 Pc's	
469	8083064	CABLE SET COIN OP. WMD60.C	1 Pc's	
471	8081664	Det Drawer WM Pull out	1 Pc's	
472	8081665	SIPHON Liq Softner Pull Compartment	1 Pc's	
490	8089867	INSTRUCT. WMC64P ENGLISH US/CA	1 Pc's	
490	8089868	INSTRUCT. WMC64P FRENCH US/CA	1 Pc's	

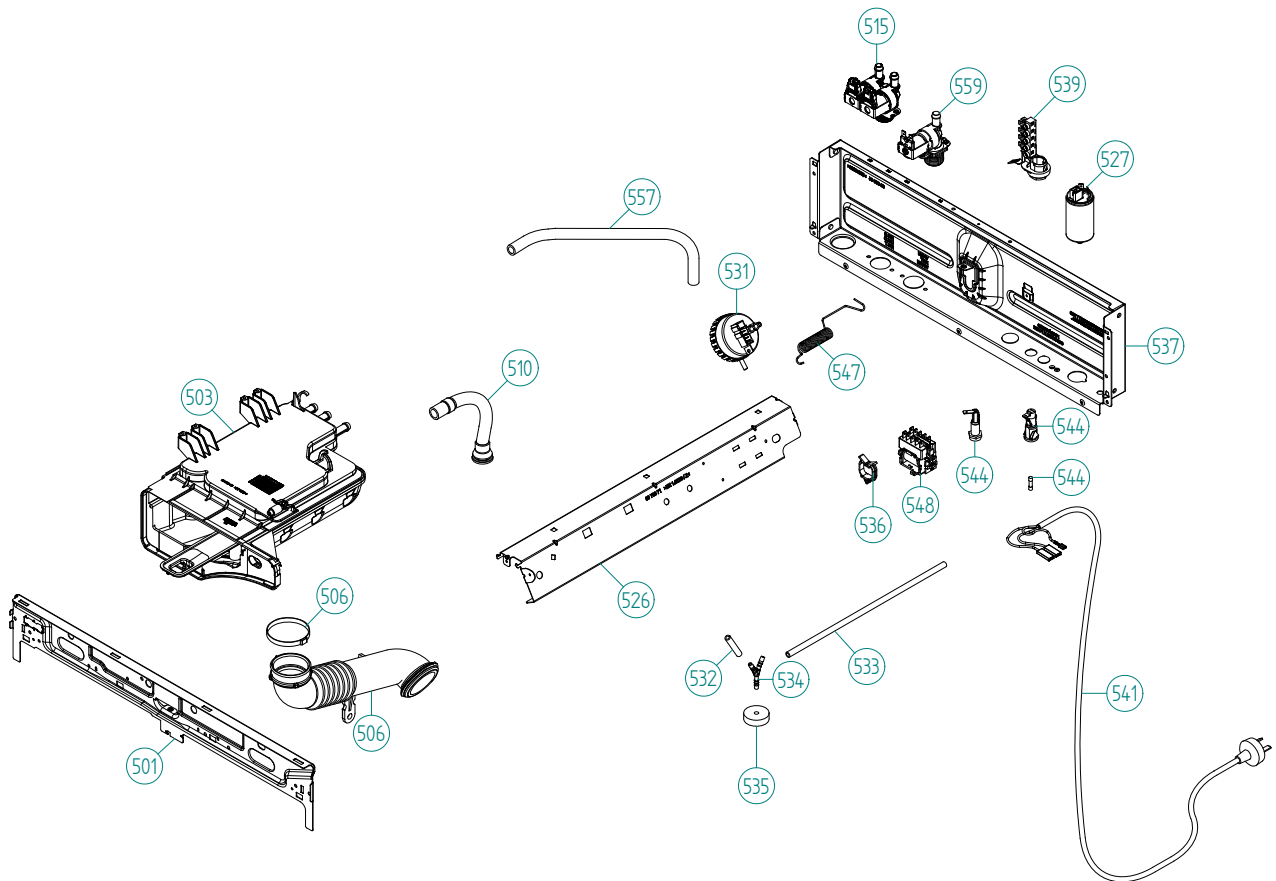

## Upper session

### ASKO, WMC 64 P US - Stainless (WM70.C)

Pos	Spare part No.	Description	Qty	Comment
501	8076029	FRONTBEAM	1 Pc's	
501-a	8902362	Screw 20 Torx Self Tapping	2 Pc's	
501-b	8901413	Lock Washer laundry tops	2 Pc's	
503	8081666	Det Comp Compl WM Pull out	1 Pc's	
503-a	8901970	Screw	1 Pc's	
503-b	8902072	SCREW PT KB40X10 WN1442 GALV	1 Pc's	
506	8064692	BELLOW HOSE INLET UL4	1 Pc's	
506-a	8063607	HOSE CLIP 57,5	1 Pc's	
510	8061736	Ventilation Hose WM20	1 Pc's	
510-a	8052730	HOSE CLIP 21,0	1 Pc's	
515	8083880	INLET VALVE 2-WAY	1 Pc's	
515-a	8901097	Screw Terminal	2 Pc's	
526	8078971	UNIT FOR ELECTR. COMP.	1 Pc's	
527	8076202	EMC-FILTER WITH INDUCTOR	1 Pc's	
527-a	8901155	Nut	1 Pc's	
527-b	8901419	Lock Washer	1 Pc's	
529	8079710	CABLE SET IV WM UL4	1 Pc's	
529	8079716	CABLE SET N AP LL WM UL4	1 Pc's	
529	8079714	CABLE SET MC C CIM-A W UL4	1 Pc's	
529	8082568	CABLE SET P WM UL4	1 Pc's	
529	8082569	CABLE SET MC P WM UL4	1 Pc's	
529	8083063	CABLE SET IV3 WM60.C UL4	1 Pc's	
529	8083057	CABLE SET EL WM60.C UL4	1 Pc's	
529	8089033	CABLE SET MOTOR A WM UL4	1 Pc's	
531	8089766	LEVEL SWITCH WM70	1 Pc's	
532	8080832	RUBBER HOSE 4,3X7,3X72	1 Pc's	
533	8080617	RUBBER HOSE 4,3X7,3X260	1 Pc's	
534	8051843	Y Pipe Water Level SW WM	1 Pc's	
535	8061997	Ground Level Switch Hose WM20	2 Pc's	
536	8061975	Cable Holder	1 Pc's	
537	8089748	CROSS BEAM	1 Pc's	
537-a	8900327	Screw 20 Torx Self Tapping	5 Pc's	
539	8061660	Terminal Block 5Pole	1 Pc's	
539-a	8901097	Screw Terminal	1 Pc's	
541	8064210	PWR Cord w/flat pin sleeves	1 Pc's	
544	8065573	FUSE HOLDER GREY 15A US/CA	2 Pc's	
544-a	8058140	BK/MDA15 Fuse All laundry	2 Pc's	
544-b	8801354	Fuse Holder Assembly	2 Pc's	For units produced before wk 34 2002
544-c	8801354	Fuse Holder Assembly	2 Pc's	For units produced before wk 34 2002
547	8095135	BALANCING SPRING	1 Pc's	
547	8089723	BALANCING SPRING	2 Pc's	
548	8064179	Relay 10 terminals WM	1 Pc's	
557	8058502	RUBBER HOSE 10X15X360 UL1	1 Pc's	
559	8083315	INLET VALVE 1-WAY	1 Pc's	

——— WIRES IN ALL MACHINES  
 - - - WIRES IN SOME MACHINES  
 - - - INTERNAL CONNECTION

**CABLE POSITIONS**  
 1: MOTOR COMMUNICATION  
 2: THERMISTOR  
 3: INLET VALVES  
 4: DOOR LOCK, DRAIN PUMP, PREASSURE SWITCH  
 6: COMMUNICATION INTERFACE  
 7: COIN COLLECTOR  
 8: POWER  
 9: HEATING ELEMENT, PREASSURE SWITCH  
 10: MOTOR POWER

**RESISTANCES AT ROOM TEMPERATURE (CA. 20°C/68°F)**  
 VALUES WITHIN +/-10% ARE REGARDED AS NORMAL COMPONENT

F: RADIO INTERFERENCE SUPPRESSION FILTER	680K Ohm
EL: HEATING ELEMENT	25 Ohm
AP: DRAIN PUMP 50 Hz	144 Ohm
AP: DRAIN PUMP 60 Hz	76 Ohm
AV: DRAIN VALVE	110/134 Ohm
LL: DOOR LOCK, 1-2	122 Ohm
NTC: THERMISTOR	6.1 - 3.8 K Ohm
IV 1: INLET VALVE 1	3.7 K Ohm
IV 2: INLET VALVE 2	3.7 K Ohm
IV3: INLET VLAVE 3	3.5 K Ohm
MO: MOTOR, 1-3	4,3±7% Ohm
1-2	4,3±7% Ohm
2-3	4,3±7% Ohm

**MCU: MOTOR CONTROL UNIT**  
 N: PRESSURE SWITCH  
 TS: PRESSURE SENSOR  
 TG: TACHO GENERATOR  
 BA: CONTAINER  
 INKB: INCOMING GROUND  
 CI: COMMUNICATIONS INTERFACE

**USER SETTINGS MENU**  
 TURN OFF POWER (S1)  
 WAIT FOR AT LEAST 5 SEC  
 HOLD S5  
 TURN ON POWER (S1)  
 PRESS S5 5 TIMES TO ENTER MENU

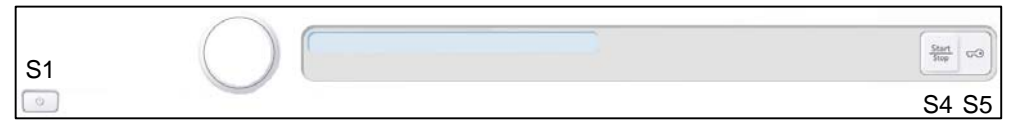
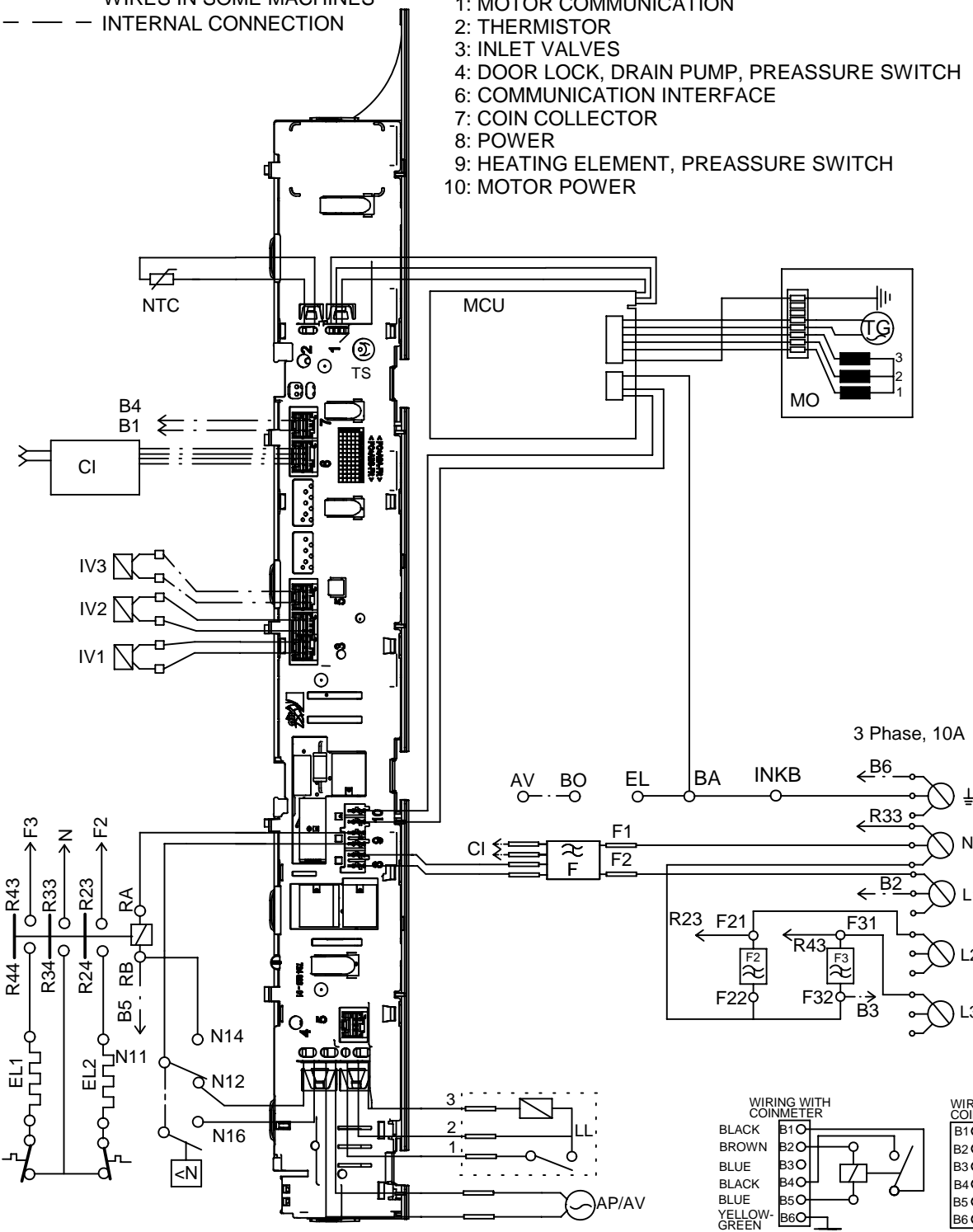

**SERVICE MENU**  
 TURN OFF POWER (S1)  
 WAIT FOR AT LEAST 5 SEC  
 HOLD S4  
 TURN ON POWER (S1)  
 PRESS S4 5 TIMES TO ENTER SERVICE MENU

PRESS DOOR OPENING (S5) TO CHANGE MENU STEP  
 ROTATE DIAL TO CHANGE IN STEP  
 PRESSING START/STOP (S4) STORES AND EXITS SERVICE MENU

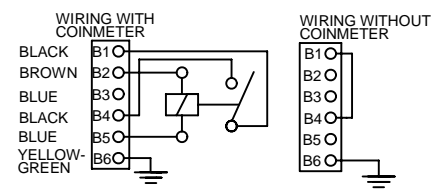
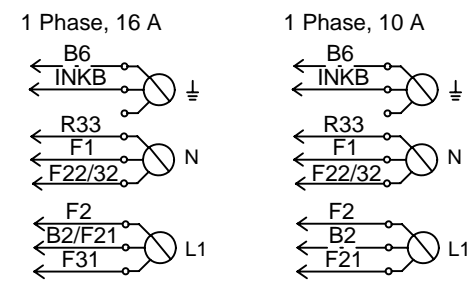

2009-12-17

CIRCUIT DIAGRAM WM70.C  
**80 886 19 - 00**

This document must not be copied without our written permission, and the contents thereof must not be imparted to a third party nor be used for any unauthorized purpose. Contravention will be prosecuted. Asko Appliance AB