



## Spare Parts Catalogue

Washing machines \ 6000 Series  
Type: WM50US  
Model: W6441 US Titanium

Prod. No: 107644116  
November 16th 2004

**AM Appliances Group**

P.O. Box 851805 • Richardson • TX 75085-1805  
789 N. Grove Road • Suite 103 • Richardson • TX 75081

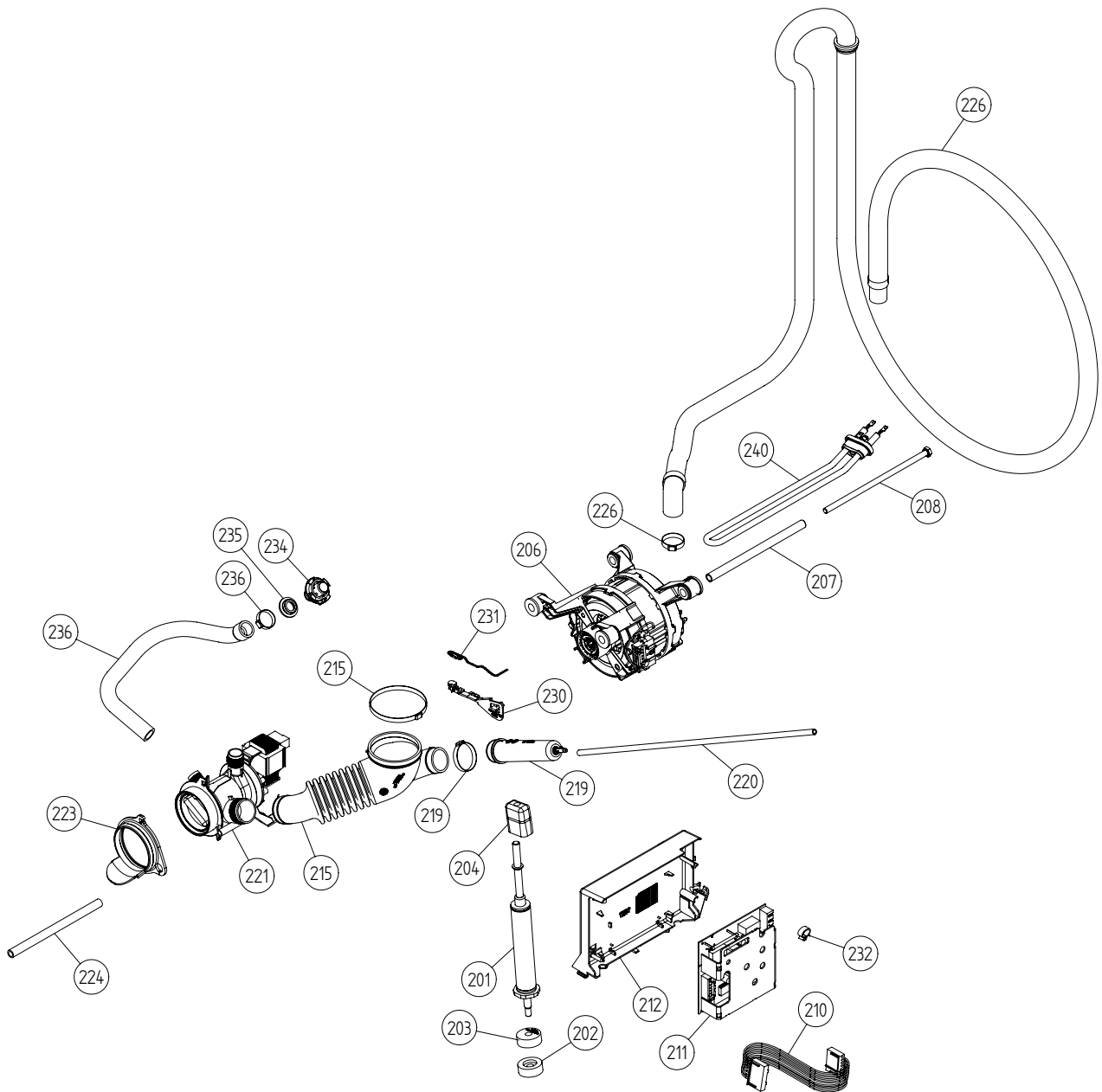

## Lower session

### ASKO, W6441 US - Titanium (WM50US)

Pos	Spare part No.	Description	Qty	Comment
201	8801171	SPRING LEG KIT WM20	1 Pcs	
202	8055796	RUBBER BUFFER SPRING LEG	4 Pcs	
203	8055797	RUBBER BUFFER SPRING LEG	4 Pcs	
204	8061668	RUBBER DAMPER SPRINGLEG	4 Pcs	
206	8063734	MOTOR FHP 50/60HZ WM55/66 UL4	1 Pcs	
206-a	8901155	NUT M6M8 BH8 GALV	2 Pcs	
206-b	8901337	WASHER BRB 84X16 HB 200 GALV	1 Pcs	
206-c	8801195	BRUSH WITH SWITCH-OFF FHP	1 Pcs	
207	8058261	SPACTUBE MOTOR SUSP 12X191	2 Pcs	
208	8063591	SCREW 88 M8x205 FZB	2 Pcs	
210	8086404	CABLE SET ST2-MO WM66/55	1 Pcs	
211	8061399	CONTROL UNIT MOTOR CHOPPERUL4	1 Pcs	
212	8061918	HOLDER MOTOR CONTROLLER WM20	1 Pcs	
212-a	8901097	SCREW MRT-TT 4X12 FZB T20	1 Pcs	
212-b	8901322	WASHER SRB 43X12X1 GALV	1 Pcs	
215	8061681	BELLOWS HOSE OUTLET PUMP UL4	1 Pcs	
215-a	8063262	HOSE CLIP 800-708	1 Pcs	
215-b	8056471	HOSE CLIP	1 Pcs	
215-c	8052083	HOSE CLIP RFZ 396-706R	1 Pcs	
219	8061924	PRESSURE CHAMBER WM20 UL4	1 Pcs	
219-c	8052083	HOSE CLIP RFZ 396-706R	1 Pcs	
220	7382670	RUBBER HOSE 5X8X550	1 Pcs	
221	8801167	DRAIN PUMP SYNCHANCOMPL60HZ	1 Pcs	
222	8061649	RUBBER BUFFERDRAIN PUMP WM20	2 Pcs	
223	8061796	RUBBER RING DRAINPUMP WM20	1 Pcs	
224	8061725	DRAIN HOSE 180mm WM20	1 Pcs	
224-a	8052731	HOSE CLIP OETIKER 148-706R	1 Pcs	
226	8061998	OUTLET HOSE WM20 UL4	1 Pcs	
226-a	8056491	HOSE CLIP 301-708	1 Pcs	
230	8061738	HOLDER THERMISTOR WM20	1 Pcs	
231	8061663	THERMISTOR (E30) UL4	1 Pcs	
232	8061976	CABLE HOLDER SMALL	2 Pcs	
234	8061674	RECIRKULATION STUB	1 Pcs	
235	8061673	GROMMET RECIRK STUB	1 Pcs	
236	8063721	HOSE RECIRKULATION WM20	1 Pcs	
236-a	8054196	HOSE CLIP FZB 228-256	2 Pcs	
240	8061706	HEATING ELEMENT 2000W 230V UL4	1 Pcs	

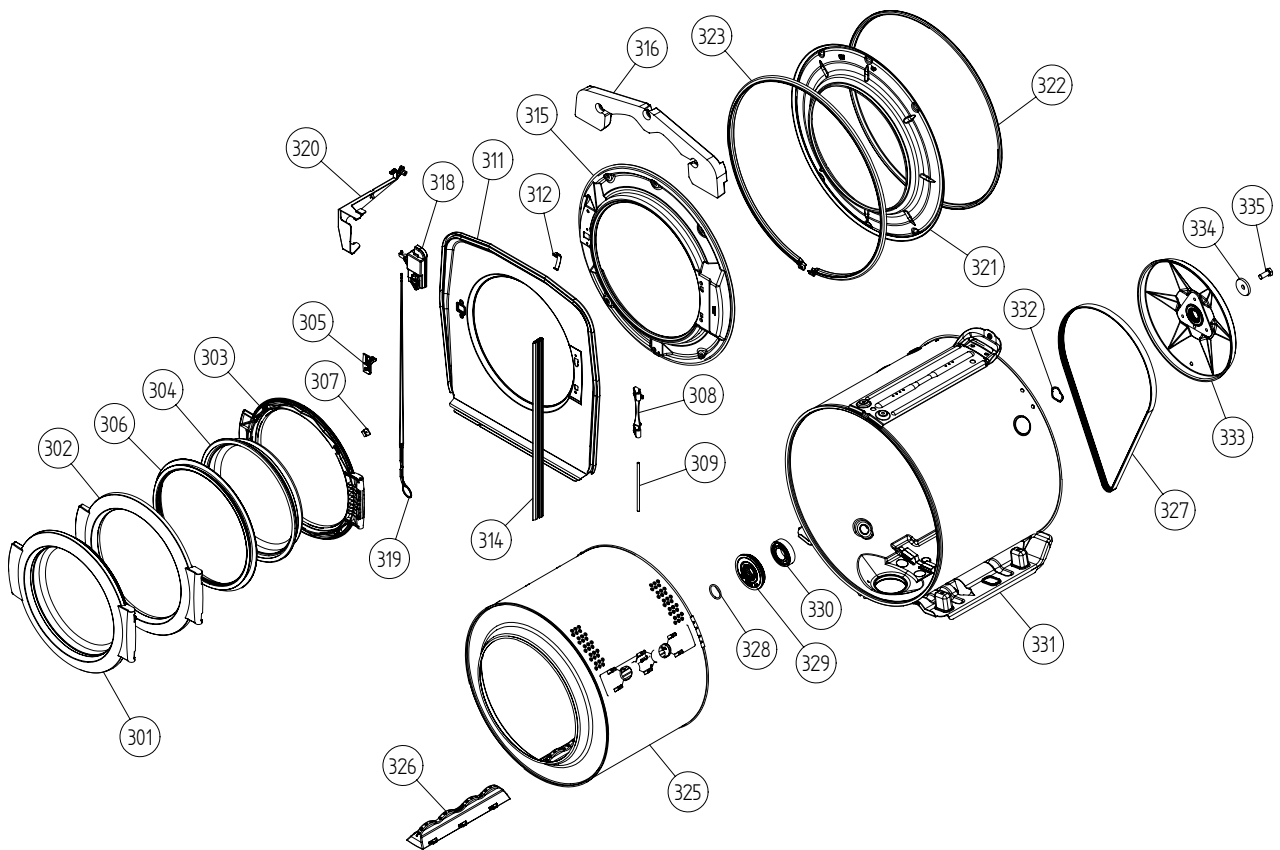

## Cylinder and related parts

### ASKO, W6441 US - Titanium (WM50US)

Pos	Spare part No.	Description	Qty	Comment
301	8064906-42	FRONT DOOR CPLVELOUR/GREY UL4	1 Pcs	
302	8061651-96	FRAME FRONT DOOR OUTER VELOUR	1 Pcs	
303	8061652-42	FRAME FRONT DOOR INNER WM20	1 Pcs	
304	8061685	FRONT GLASS D306x42mm WM20	1 Pcs	
305	8061798	LOCK HOOK WM20	1 Pcs	
306	8064025	SEALING FRONT DOOR	1 Pcs	
307	8061624	SECURING PLATE FRONTGLAS	4 Pcs	
308	8061686-42	HINGE FRONT DOOR GREY WM20	1 Pcs	
308-a	8901969	SCREW MRT-TT 5x12 FZB T20	2 Pcs	
309	8061687	SHAFT FOR HINGE WM20	1 Pcs	
311	8061671-81	COVER PLATE OUTER GREYMET	1 Pcs	
312	8061879	TENSIONSPRING COVERPLATE OUTER	4 Pcs	
314	8061616	GAPSEALING SIDE WM20	2 Pcs	
315	8061670	COVER PLATE INNER	1 Pcs	
316	8061678	DAMPER WEIGHT	2 Pcs	
316-a	8901135	SCREW M6SF-TT 8X25 FZB	4 Pcs	
318	8061679	DOOR LOCK WM20 UL4	1 Pcs	
318-a	8902087	SCREW PTK 40X14 WN1452 FZB T20	2 Pcs	
319	8061780	EMERGENCY OPENING COMPL WM20	1 Pcs	
320	8061680-UL	CONTACT GUARD DOOR LOCK UL4	1 Pcs	
321	8061677	FRONT PANEL TUB WM20	1 Pcs	
321	8065043	FRONT PANEL TUB/2 WM20	1 Pcs	
322	8061889	SEALING STRIP FRONT PANEL(TUB)	1 Pcs	
323	8061669	TENSION RING WM20	1 Pcs	
325	8061600	CYLINDER COMPL WM20	1 Pcs	
326	8061604	DRUM PADDLE WM20	3 Pcs	
327	8061682	DRIVE BELT 5EPJ 1209	1 Pcs	
328	8058497	O-RING 262X3 NBR70	1 Pcs	
329	8801211	V-RING CASSETTE COMPL WO-RING	1 Pcs	
330	8056314	BALL BEARING 6206 2RS MTSRL	2 Pcs	
331	8801165	CONTAINER CPLW BEARING HOUSE	1 Pcs	
332	8056810	SCALE WASHER 37x305x05	1 Pcs	
333	8056376	PULLEY COMPL D292	1 Pcs	
334	8057209	WASHER 42X10X4	1 Pcs	
335	8901052	SCREW BUFO 88 10X25 GALV	1 Pcs	

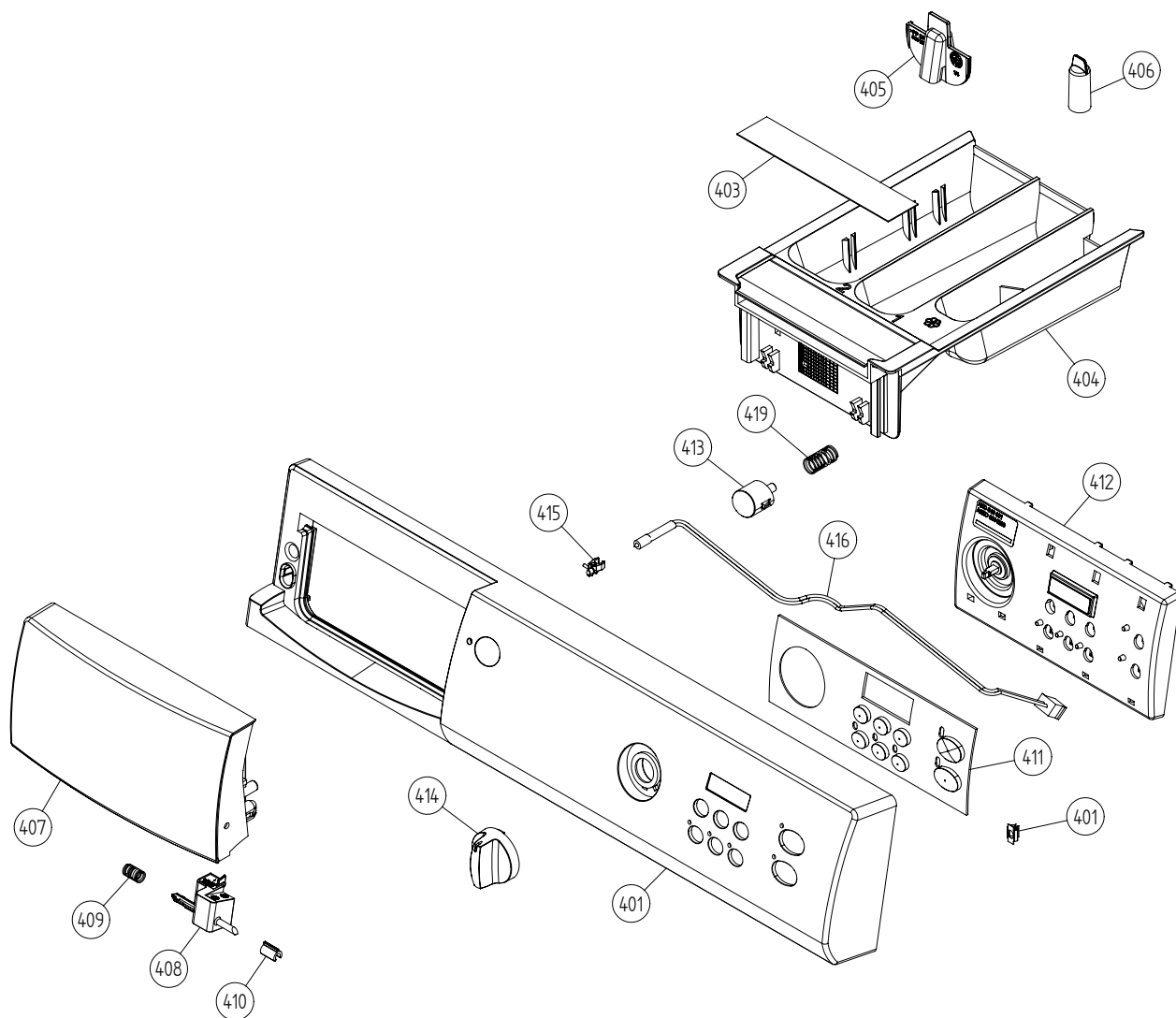

## Control panel

### ASKO, W6441 US - Titanium (WM50US)

Pos	Spare part No.	Description	Qty	Comment
401	8076553-81-UL	PANEL W.HANDLE W6441 ASKO US	1 Pcs	
401	8076191-81-UL	PANEL WHANDLE W6441 ASKO US	1 Pcs	
401-a	8901591	BINDING CLIP SCO 5740	4 Pcs	
403	8076556-49	PLATE PROG.INFO WASHERS US/CA	1 Pcs	
403	8076660-49	PLATE PROG.INFO WM F. US FR/ES	1 Pcs	
403	8063402-49	PLATE PROGINFO 33/44/50 FR/ES	1 Pcs	
404	8061630	DETERGENT COMP WM20	1 Pcs	
405	8061633	DIVIDER DETERGENT COMP	1 Pcs	
406	8061634	SIPHON WM20	1 Pcs	
407	8061846-81-UL	HANDLE PANEL MECH WMD20	0 Pcs	
408	8061621-34	SAFETY CATCH HANDLE RED	1 Pcs	
409	8061622	SPRING SAFETY CATCH HANDLE	1 Pcs	
410	8064010	SPACING SLEEVE SAFETY CATCH	1 Pcs	
411	8065515-81	PUSHBUTTONS WITH PRINT WM50	1 Pcs	
412	8064260	DISPLAY UNIT WM50TD30/40 UL4	1 Pcs	
413	8061902-81	PUSH BUTTON MAINSWITCH WMD20	1 Pcs	
414	8064390-81	KNOB WM50TD30/40 WITH PRINT	1 Pcs	
415	8061822	DECOR LENS	1 Pcs	
416	8064068	INDICATION LAMP WM55/66 UL	1 Pcs	
419	8061857	SPRING MAIN SWITCH WMD20	1 Pcs	
490	8076667	INSTRUCT. WM21 ENGLISH US/CA	1 Pcs	
490	8065659	INSTRUCT WM21 ENGLISH US/CA	1 Pcs	
490	8065660	INSTRUCTIONS WM21 FRENCH US/CA	1 Pcs	
490	8065661	INSTRUCT WM21 SPANISH US/CA	1 Pcs	
490	8065677	INSTRUCTIONS W6441 ASKO US GB	1 Pcs	
490	8065678	INSTRUCTIONS W6441 ASKO US FR	1 Pcs	
490	8065679	INSTRUCTIONS W6441 ASKO US ES	1 Pcs	
490	8076668	INSTRUCTIONS WM21 FRENCH US/CA	1 Pcs	
490	8076669	INSTRUCT. WM21 SPANISH US/CA	1 Pcs	

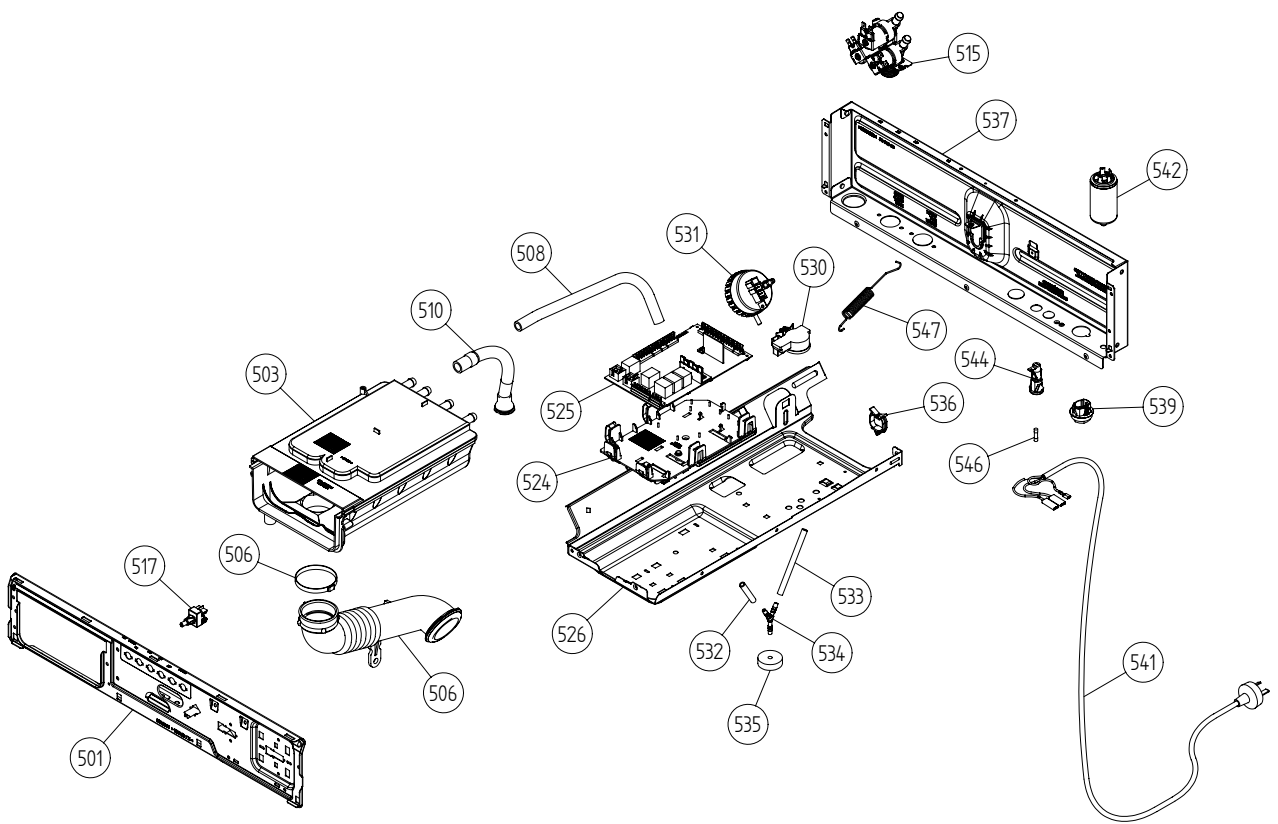



## Upper session

### ASKO, W6441 US - Titanium (WM50US)

Pos	Spare part No.	Description	Qty	Comment
501	8061690	BEAM FRONT WMD20	1 Pcs	
501-a	8900338	SCREW RTK ST 42X95 FZB T20	2 Pcs	
501-b	8901413	LOCK WASHER AZ 43 GALV	2 Pcs	
501-c	8902087	SCREW PTK 40X14 WN1452 FZB T20	2 Pcs	
503	8061661	CONTAINER DETERGENT COMP	1 Pcs	
503-a	8901970	SCREW PTK 40X12 A2 WN1452 T20	2 Pcs	
503-b	8902072	SCREW PT KB40X10 WN1442 GALV	1 Pcs	
503-c	8056656	CABLE STRIP	3 Pcs	
506	8064692	BELLOW HOSE INLET LONG UL4	1 Pcs	
506	8061628	BELLOWS HOSE INLET WM20	1 Pcs	
506-a	8063607	HOSE CLIP 575-708	1 Pcs	
508	8061702	RUBBER HOSE 10x15x300	3 Pcs	
510	8061736	VENTILATION HOSE WM20 UL4	1 Pcs	
510-a	8052730	HOSE CLIP OETIKER 210-706R	1 Pcs	
515	8061757	INLET VALVE 3-WAY WM20	1 Pcs	
515-a	8901097	SCREW MRT-TT 4X12 FZB T20	2 Pcs	
517	8061875	PUSHBUTTONSW 2-POLE CLOS	1 Pcs	
524	8061921	HOLDER PROGCONTROLLER WMD20	1 Pcs	
525	8076640	CONTROL UNIT WM50/55 UL4	1 Pcs	
526	8061692	BRACKET FOR ELECCOMP WM20	1 Pcs	
526-a	8900338	SCREW RTK ST 42X95 FZB T20	2 Pcs	
526-b	8900327	SCREW RTS ST 42X13 FZB T20	1 Pcs	
529	8086447	Add Harness WM66/55	1 Pcs	
530	8061664	PRESSURE SENSOR TYPE 1166 UL4	1 Pcs	
531	8064275	LEVEL SWITCH WM21 UL4	1 Pcs	
532	8003641	RUBBER HOSE 5X8X45	1 Pcs	
533	7382985	RUBBER HOSE 5X8X100	1 Pcs	
534	8051843	Y-PIPE 05	1 Pcs	
535	8061997	GUARD LEVELSWITCH HOSE WM20	2 Pcs	
536	8061975	CABLE HOLDER BIG	1 Pcs	
537	8061694	CROSS BEAM	1 Pcs	
537-a	8900327	SCREW RTS ST 42X13 FZB T20	4 Pcs	
539	8006948	GROMMET Z13	1 Pcs	
541	8064210	CORDSET W FLAT PIN SLEEVES US	1 Pcs	
542	8058558	RADIOINTERFSUPP FILTER	1 Pcs	
542-a	8901168	NUT Replby 8901155	1 Pcs	
542-b	8901419	LOCK WASHER AZ 84 GALV	1 Pcs	
544	8065573	FUSE HOLDER GREY 15A US/CA	2 Pcs	
544-a	8058140	FUSE 15AT 63X32	2 Pcs	
544-b	8055725	FUSE HOLDER INSERT STI	2 Pcs	
544-c	8054613	FUSE HOLDER HTB38	2 Pcs	
547	8061923	BALANCING SPRING WM20	2 Pcs	

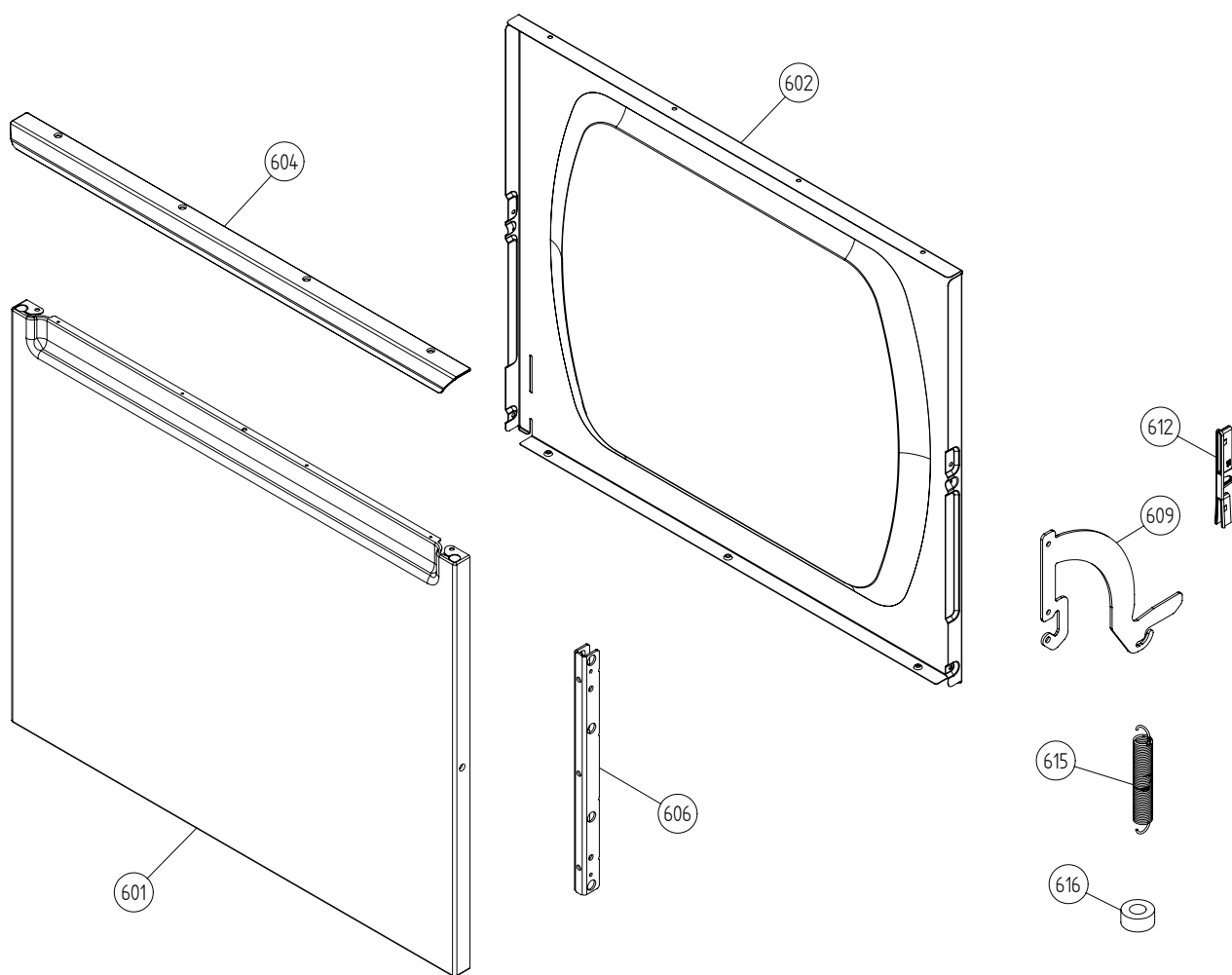

## Outer door

### ASKO, W6441 US - Titanium (WM50US)

Pos	Spare part No.	Description	Qty	Comment
601	8061733-81	DOOR OUTER PART GREYMET WMD20	1 Pcs	
602	8061734	DOOR INNER PART CROMED WM20	1 Pcs	
604	8061656-81	HANDLE FRONT DOOR GREYMET	1 Pcs	
606	8061764	REINFORCEMENT HINGE WM20	1 Pcs	
606-a	8901969	SCREW MRT-TT 5x12 FZB T20	4 Pcs	
606-b	8901097	SCREW MRT-TT 4X12 FZB T20	4 Pcs	
609	8061906	HINGE ELECTRIC GALVANIZ WM20	2 Pcs	
609-a	8901192	NUT LOCKING 6 BH8 GALV	2 Pcs	
609-b	8901004	SCREW BUFO 88 6X16 GALV	2 Pcs	
609-c	7382628	WASHER NYLON 62X14X1	2 Pcs	
612	8061777-81	GUIDE HINGE GREY	2 Pcs	
615	8061742	EXTENSION SPRING HINGE WM20	1 Pcs	
616	8061909	GLIDESLEEVE TENSIONSPRING WM20	1 Pcs	

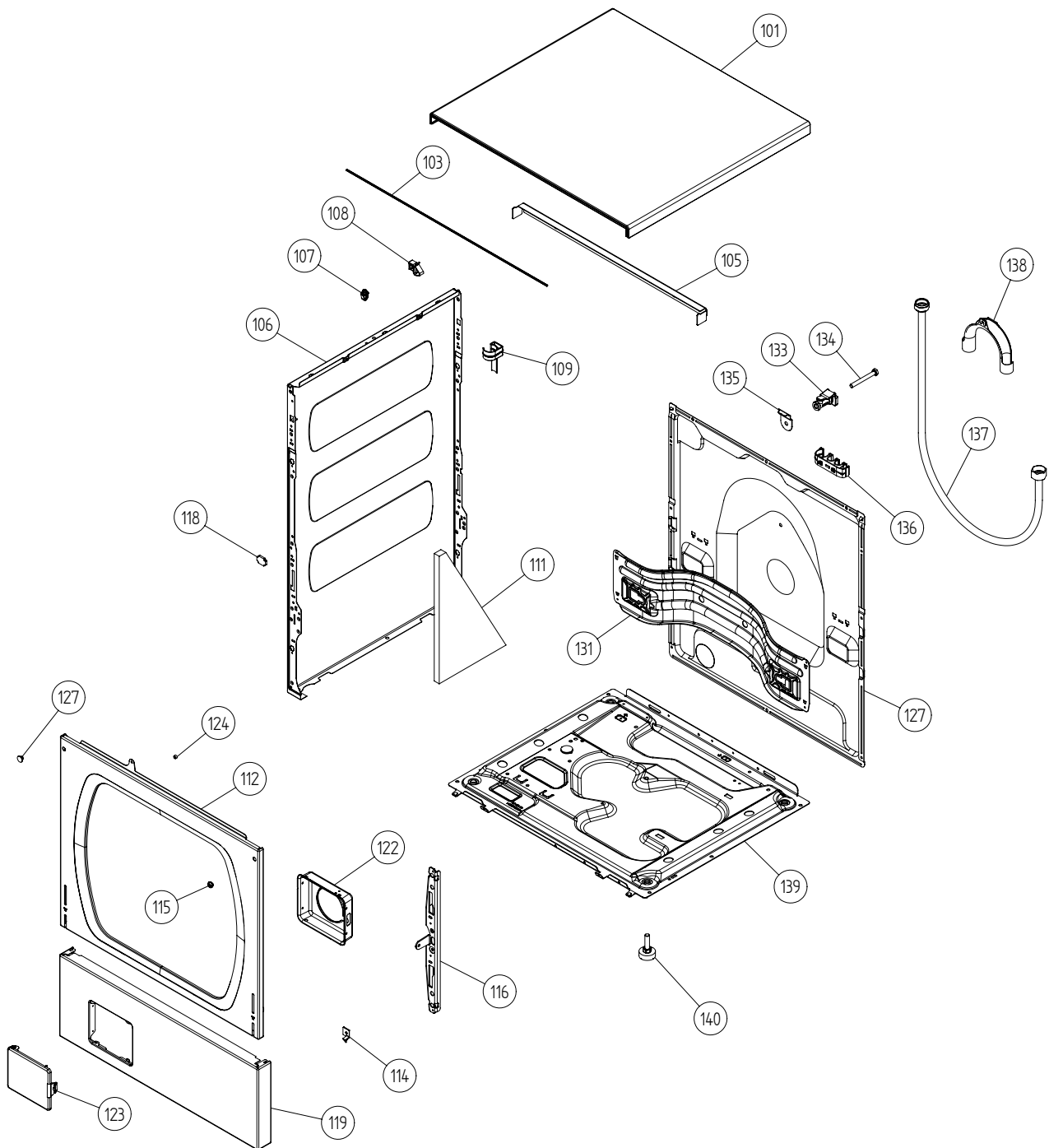

## Outer casing

### ASKO, W6441 US - Titanium (WM50US)

Pos	Spare part No.	Description	Qty	Comment
101	8061817-81	TOP COVER GREY METALLIC	1 Pcs	
101-a	8900338	SCREW RTK ST 42X95 FZB T20	3 Pcs	
101-b	8901413	LOCK WASHER AZ 43 GALV	2 Pcs	
103	8064062	STRIP TOP COVER WMD20 UL4	1 Pcs	
105	8064198	SUPPORT BEAM TOP COVER	1 Pcs	
106	8801174-81	SIDE PLATE COMPL WM20	2 Pcs	
107	8061763	GUIDE FRONT PLATE/TOP COVER	2 Pcs	
108	8061916	CABLE HOLDER WMD20 UL4	3 Pcs	
109	8061713	HOLDER HOSE SIDE PLATE UL4	2 Pcs	
111	8064017	SOUND DEADSHEET OUTLET HOSE	1 Pcs	
112	8061732-81	FRONT PLATE GREY METALLIC	1 Pcs	
112-a	8900327	SCREW RTS ST 42X13 FZB T20	4 Pcs	
112-b	8901413	LOCK WASHER AZ 43 GALV	2 Pcs	
114	8064177	HOOK LOWER PANEL UL4	2 Pcs	
114-a	8900338	SCREW RTK ST 42X95 FZB T20	2 Pcs	
115	8061741	RUBBER BUFFER FRONT DOOR WM20	2 Pcs	
116	8061744	HINGE BEARING	2 Pcs	
116-a	8901097	SCREW MRT-TT 4X12 FZB T20	6 Pcs	
118	8061745	RUBBER BUFFER HINGE WM20	2 Pcs	
119	8064294-81	LOWER COVER COMPL GREY MET	1 Pcs	
119-a	8900327	SCREW RTS ST 42X13 FZB T20	2 Pcs	
119-b	8901413	LOCK WASHER AZ 43 GALV	2 Pcs	
122	8061785	PUMP GUARD WM20	1 Pcs	
123	8061657-81	DOOR OUTLET PUMP GREY METALLIC	1 Pcs	
127	8061737	REAR PANEL WM20	1 Pcs	
127-a	8061959	PLUG HUMIDITY SENSOR/REAR PAN	1 Pcs	
127-b	8900338	SCREW RTK ST 42X95 FZB T20	11 Pcs	
131	8061693	TRANSPORT BEAM	1 Pcs	
131-a	8900338	SCREW RTK ST 42X95 FZB T20	4 Pcs	
131-b	8901413	LOCK WASHER AZ 43 GALV	1 Pcs	
133	8064206-UL	TRANSPORT SLEEVE COMPL WHUL4	3 Pcs	
134	8901940	SCREW M6S M8X70 FZB WGUIDE	3 Pcs	
134	8901037	SCREW BUFO 88 8X70 GALV	3 Pcs	
135	8061767	LOCKINGWASHER CROSSBAR WM20	3 Pcs	
136	8065773	HOLDER FRAME REAR COVER	2 Pcs	Bild saknas
137	8056950	CONNECPIPE W-1500-15-3/4-3/4	1 Pcs	
138	8050805	HOLDER HOSE UL4	1 Pcs	
138-a	8002263	CABLE STRIP 200 MM	1 Pcs	
139	8061618	BOTTOM WMD20	1 Pcs	
140	8059334	RUBBER FOOT D35xM10 INC NUT	4 Pcs	

KOMPLETTSCHEMA WM50: 80 643 93

SU:WM50#2011\_Tryckunderlag\Kopplingschema\8064394\_KWM50-01.dft, sssv, 6/11/01 9:27:06 AM

This document must not be copied without our written permission, and the contents may not be used for any unauthorized purpose. Askö Cylinda AB

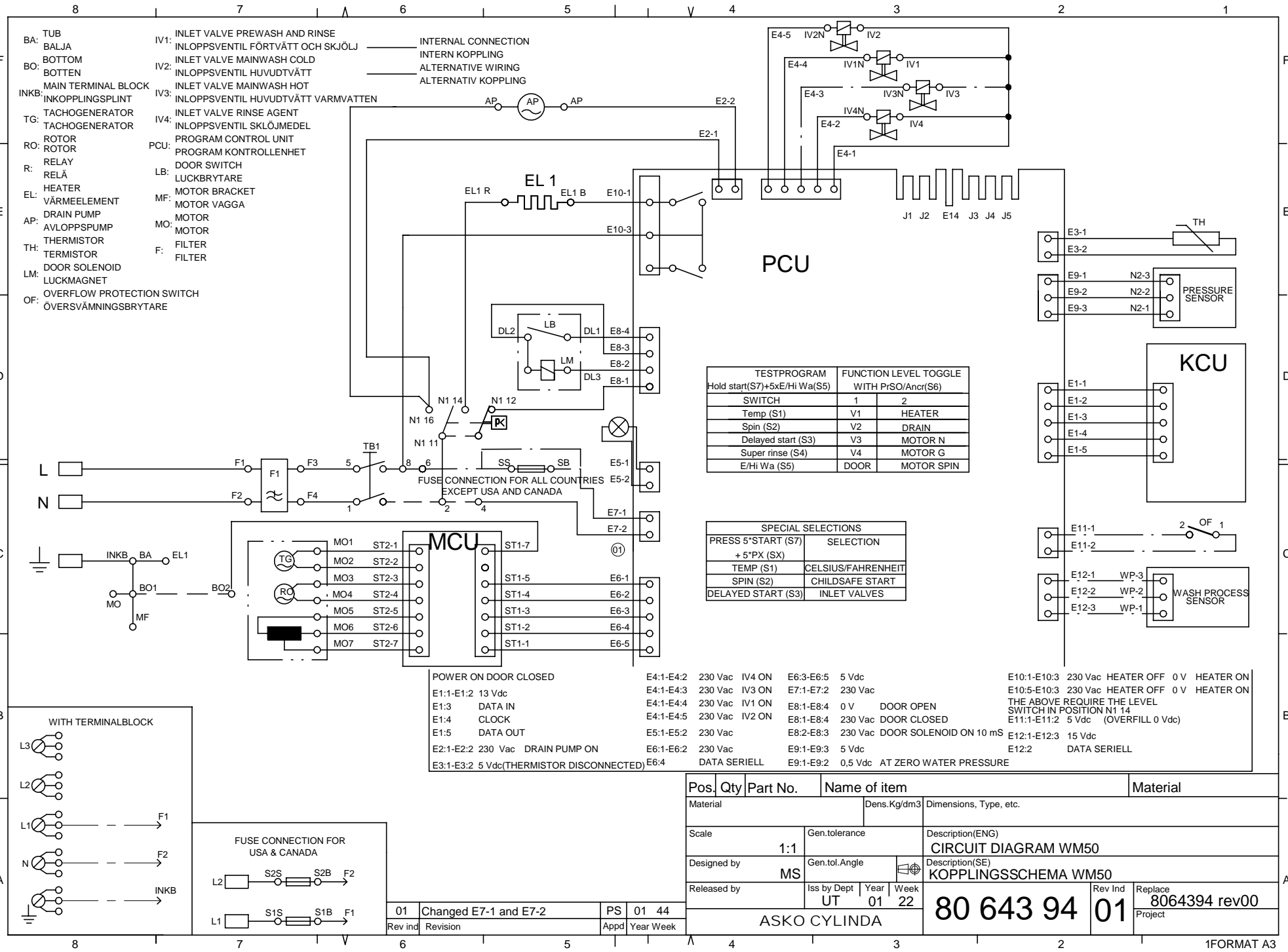

- BA: TUB
- BO: BOTTOM
- INKB: MAIN TERMINAL BLOCK
- TG: TACHOGENERATOR
- RO: ROTOR
- R: RELAY
- EL: HEATER
- AP: DRAIN PUMP
- AVLOPPSPUMP
- TH: THERMISTOR
- LM: DOOR SOLENOID
- OF: OVERFLOW PROTECTION SWITCH
- IV1: INLET VALVE PREWASH AND RINSE
- IV2: INLET VALVE MAINWASH COLD
- IV3: INLET VALVE MAINWASH HOT
- IV4: INLET VALVE RINSE AGENT
- PCU: PROGRAM CONTROL UNIT
- LB: DOOR SWITCH
- MF: MOTOR VAGGA
- MO: MOTOR
- F: FILTER

- INTERNAL CONNECTION
- INTERN KOPPLING
- ALTERNATIVE WIRING
- ALTERNATIV KOPPLING

TESTPROGRAM	FUNCTION LEVEL TOGGLE	
Hold start (S7)+5x E/Hi Wa (S5)	WITH PrSO/Ancr (S6)	
SWITCH	1	2
Temp (S1)	V1	HEATER
Spin (S2)	V2	DRAIN
Delayed start (S3)	V3	MOTOR N
Super rinse (S4)	V4	MOTOR G
E/Hi Wa (S5)	DOOR	MOTOR SPIN

SPECIAL SELECTIONS	
PRESS 5*START (S7) + 5*PX (Sx)	SELECTION
TEMP (S1)	CELSIUS/FAHRENHEIT
SPIN (S2)	CHILDSAFE START
DELAYED START (S3)	INLET VALVES

POWER ON DOOR CLOSED								
E1:1-E1:2	13 Vdc	E4:1-E4:2	230 Vac	IV4 ON	E6:3-E6:5	5 Vdc		
E1:3	DATA IN	E4:1-E4:3	230 Vac	IV3 ON	E7:1-E7:2	230 Vac		
E1:4	CLOCK	E4:1-E4:4	230 Vac	IV1 ON	E8:1-E8:4	0 V DOOR OPEN		
E1:5	DATA OUT	E4:1-E4:5	230 Vac	IV2 ON	E8:1-E8:4	230 Vac DOOR CLOSED		
E2:1-E2:2	230 Vac DRAIN PUMP ON	E5:1-E5:2	230 Vac	E8:2-E8:3	230 Vac	DOOR SOLENOID ON 10 mS		
E3:1-E3:2	5 Vdc (THERMISTOR DISCONNECTED)	E6:1-E6:2	230 Vac	E9:1-E9:3	5 Vdc	E12:1-E12:3	15 Vdc	
		E7:1-E7:2	230 Vac	E9:1-E9:2	0,5 Vdc	AT ZERO WATER PRESSURE		
							E10:1-E10:3	230 Vac HEATER OFF 0 V HEATER ON
							E10:5-E10:3	230 Vac HEATER OFF 0 V HEATER ON

Pos.	Qty	Part No.	Name of item	Material
Material		Dens.Kg/dm3		Dimensions, Type, etc.
Scale		Gen.tolerance		Description(ENG)
1:1				CIRCUIT DIAGRAM WM50
Designed by		Gen.tol.Angle		Description(SE)
MS				KOPPLINGSSCHEMA WM50
Released by		Iss by	Dept	Year
		UT	01	22
		Week		
		22		
ASKO CYLINDA				Rev Ind
80 643 94				01
Replace				8064394 rev00
Project				

Rev ind	Revision	Appd	Year	Week
01	Changed E7-1 and E7-2	PS	01	44

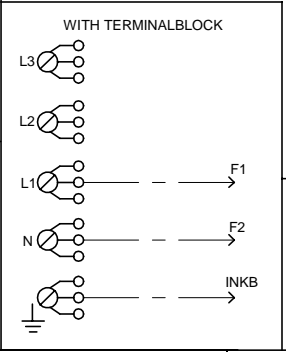
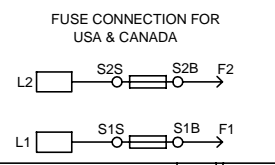

# 5 RINSES

NUMBER	PROGRAM	TEMPERATUR (MIN / MAX)	SPIN SPEED	PRE WASH	MAIN WASH (MIN / MAX)	SPIN	RINSE 1	RINSE 2	RINSE 3	SPIN	RINSE 4	RINSE 5	SPIN (max)	LOAD SIZE
		°C	rpm	min.	min.	min.	min.	min.	min.	min.	min.	min.	min.	
1	HEAVY	0-95	MAX	10	59-105	4	7,5	5	5	4	5	5	12	● 1/1
2	NORMAL	0-95	MAX		20-105	4	7,5	5	5	4	5	5	12	● 1/1
3	LIGHT	0-95	MAX		20-60	4	7,5	5	5	4	5	5	12	● 1/1
4	SYNTHETIC	0-95	800		35-80		7,5				5	5	4	● 1/2
5	QUICK	0-95	MAX		19-55		3,5				5	5	12	● 1/2
6	SUPER QUICK	0-95	MAX		19-55		3,5					5	12	● 1/2
7	WOOL	0-40	800		9-20		7,5	5				5	4	● 1/3
8	HANDWASH	0-40	800		9-20		7,5	5				5	4	● 1/3
9	RINSE		MAX									5	12	● 1/1
10	SPIN		MAX										12	
11	DRAIN												1	

- Normal action:** Clockwise 12 seconds on 3 seconds off, counterclockwise 12 seconds on 3 seconds off, 49 rpm.
- Normal "fill" action:** Clockwise 9 seconds on 6 seconds off, counterclockwise 9 seconds on 6 seconds off, 40 rpm.  
(First 14 min of main wash)
- Super gentle action:** Clockwise 3 seconds on 57 seconds off, counterclockwise 3 seconds on 57 seconds off, 49 rpm.  
(Wool program)
- Slow super gentle action:** Clockwise 3 seconds on 57 seconds off, counterclockwise 3 seconds on 57 seconds off, 40 rpm.  
(Handwash program)
- Gentle action:** Clockwise 3 seconds on 27 seconds off, counterclockwise 3 seconds on 27 seconds off, 49 rpm.  
(Rinses in wool and handwash programs)
- Spin sequence:** Normal action clockwise and counterclockwise followed by a clockwise peak to 500 rpm, normal action clockwise and counterclockwise followed by a clockwise spin with selected spin speed. Time dep. on selected speed.

**Options: (all options are not available, in all programs)**

- Rinses:** With J3 not cut, 3 rinses will be executed. Spin between all rinses  
With J3 cut, 5 rinses will be executed.  
If super rinse is selected the machine will add two rinses.
- Presoak:** With J2 not cut, 120 min adds before main wash.  
(WM 50)
- Anticrease:** With J2 cut, 120 min adds after last spin.  
(WM 50)
- Economy:** With J1 not cut, adds 22 min to the main wash.  
(WM 50)
- High water level:** With J1 cut, more water adds to the main wash and the rinses.  
(WM 50)
- Rinse Process Sensor (RPS):** Adjusts the rinse cycle.  
(WM 66A)
- Delayed start:** 1-24 h

Sequence	Inlet valve
Pre-wash	1
Main wash	2 (3)
Rinse	1
Final rinse	1+4

All main washes starts with 4 sek on inlet valve 1

Pos.	Qty	Part No.	Name of item	Material
Material		Dens.Kg/dm3	Dimensions, Type, etc.	
Scale		Gen.tolerance		Description(ENG)
Designed by		Gen.tol.Angle		Function diagram WM 50/55A/66A
Released by		Iss by	Dept	Description(SE)
		UT	Year	Funktionsdigram WM 50/55A/66A
			01	
			Week	
			02	
ASKO CYLINDA				80 643 95
				00
				Rev Ind
				Replace
				Project
Rev ind		Revision		Appd
				Year Week

This document must not be copied without our written permission, and the contents may not be used for any unauthorized purpose. Askö Cylinda AB

S:\U\Wm2011\_Tryckunderlag\Kopplingschema\8064395 Funktionsdiagram WM50\_55\_66\8064395 Funktionsdiagram WM50\_55A\_66A.dff\_sosv , 2001-01-11 12:11:24

8      7      6      5      4      3      2      1

8      7      6      5      4      3      2      1