

This Owner's Manual is provided and hosted by [Appliance Factory Parts](#).



FANTECH FTC99210 Owner's Manual

[Shop genuine replacement parts for FANTECH
FTC99210](#)



[Find Your FANTECH Fan Parts - Select From 108 Models](#)

----- Manual continues below -----

SHR 450

Commercial Heat Recovery Ventilators

Product #: 99210



The SHR 450 Commercial Heat Recovery Ventilation system (HRV) complements today's tight buildings. Fantech Heat Recovery Ventilators (HRV) are designed to supply air into a building while exhausting an equal amount of contaminated air to the outside. The aluminum heat exchanger core transfers sensible energy between air streams resulting in tempering of the supply air and reduced loads on the HVAC system.

Feature

- Push-pull configuration
- Removable screw terminal for easy connection
- Dual service doors & reversible electrical box
- External three position switch (Low/Standby/High)
- Weighs 146 lbs (66Kg)

Applications

- Class Room
- Offices
- Retail Shops
- Clinics
- Hair Salon
- Animal Shelters
- Bars & Restaurants
- Larger Homes

Specifications

- Voltage/Phase – 120/1
- Power rated – 470 W
- Amp – 3.92 A
- Average airflow – 465 cfm (219 L/s)
@ 0.4" P_s (100Pa)

Port configuration

The unit has access doors on the front and back. Also, the main control panel may be moved from front to back allowing for ducting layout.

Warranty

Limited lifetime on aluminum core, 3 years on motors, and 3 years on parts.

Fans

Two (2) factory balanced fans with backward curved blades. Motors come with permanently lubricated sealed ball bearings and (TOP) thermal overload protected.

Heat recovery core

Fantech manufactures this fixed plate cross-flow heat exchanger using new 1100 alloy aluminum. Heat exchanger is engineered with a turbulence inducing geometry in order to maximize heat transfer while allowing an effective evacuation of condensate. The plates are hemmed and sealed to ensure no cross-contamination of airstreams. The aluminum core had a plastic handle for easy removal. Core dimensions are 11.4" x 11.4" (290x 290 mm) with a 11.4" (290 mm) depth.

Defrost

A preset frost control sequence is initiated if the outdoor temperature falls below the set point of 23°F (-5°C). During the initial stage, the supply blower shuts down & the exhaust blower switches into high speed to eliminate frost build-up in the core. The unit then returns to normal operation for the final stage of the frost control sequence at which time the sequence is repeated if the outdoor air temperatures is still below the set point.

Serviceability

Cores, filters and drain pan can be accessed easily from both sides of the HRV from hinged access panels. Cores conveniently slide out with only 15" (380 mm) clearance. Blowers can be accessed from both side of the HRV from fastened access panels. Blowers are easily removed by taking off the access panel and sliding the motor plates out of the HRV. A quick connect allows for fast inspection of blowers.

Case

22 gauge galvanized steel. Baked powder coated paint.

Insulation

Insulated with 1 in. (25 mm) fiberglass with FSK facing for condensation control.

Filters

The exhaust and fresh air streams are protected by MERV1 washable filters constructed to meet UL 900. Optional MERV6 filters are direct replacement to the MERV1. Use of MERV6 filters will add an additional system pressure of 0.52 in.wg (130 Pa) at 450 cfm (212 l/s). Additional MERV Rated filters available upon request.

Controls

External three (3) position (Low/Stand By/High) rocker switch that will offer continuous ventilation. In addition Fantech offers a variety of external controls.

Mounting

Unit may be suspended by using threaded rod, not supplied, or placed on a platform. Unit shall be adaptable for easy service of electrical components.



fantech[®]
a systemair company

Dimensions & airflow

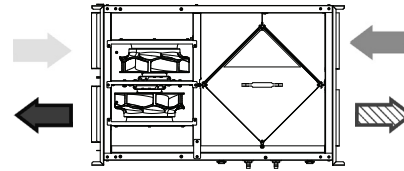
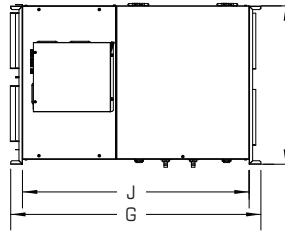
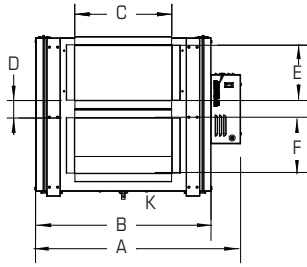

- Fresh air to inside
- Fresh air from outside
- Stale air from inside
- Stale air to outside

Model	A		B		C		D		E		F		G		I		J		K	
	in	mm	in	mm	in	mm	in	mm	in	mm	in	mm	in	mm	in	mm	in	mm	in	mm
SHR 450	29 1/2	747	25 1/8	639	14	355	2 1/2	64	8	203	8	203	35 15/16	911	22 11/16	577	32 1/2	826	1 1/2	13

Ventilation Performance

in. wg. (Pa)	0.2 (50)	0.4 (100)	0.6 (150)	0.8 (200)	1.0 (250)	1.2 (300)	1.4 (350)	1.6 (400)
	cfm (L/s)	cfm (L/s)	cfm (L/s)	cfm (L/s)	cfm (L/s)	cfm (L/s)	cfm (L/s)	cfm (L/s)
Supply High	518 (244)	465 (219)	412 (194)	358 (169)	303 (143)	248 (117)	192 (91)	135 (68)
Supply Med	406 (192)	339 (160)	265 (125)	184 (87)	-	-	-	-
Supply Low	295 (139)	210 (99)	100 (47)	-	-	-	-	-

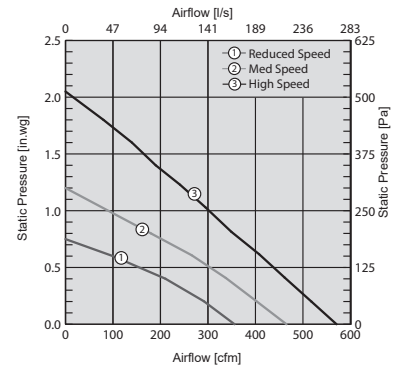

Energy performance

	Supply temperature		Net airflow		Net Effectiveness	
	°F	°C	cfm	L/s	Sensible %	Total %
Heating	35	1.7	300	142	62	41
	35	1.7	225	106	64	42
Cooling	95	35	300	142	50	19
	95	35	225	106	51	19

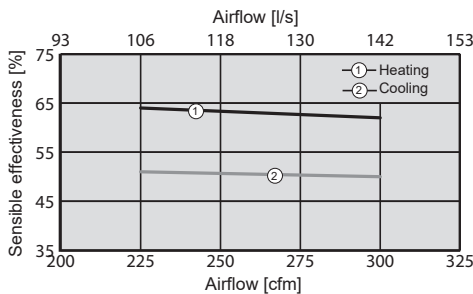

Port configuration

Standard Configuration as shipped from factory

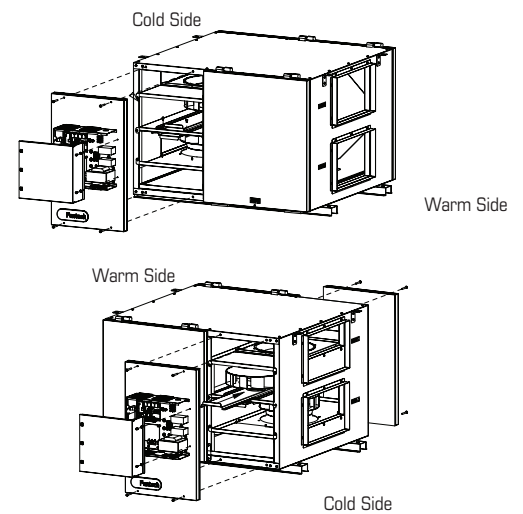

Requirements and standards

- Complies with the UL 1812 requirements regulating the construction and installation of Heat Recovery Ventilators
- Complies with the CSA C22.2 no. 113 Standard applicable to ventilators
- Technical data was obtained from published results of test relating to AHRI 1060 Standards

Contacts

Submitted by: _____	Date: _____
Quantity: _____	Model: _____
Project #: _____	
Comments: _____	
Location: _____	
Architect: _____	
Engineer: _____	Contractor: _____

Distributed by:

United States 10048 Industrial Blvd. • Lenexa, KS 66215 • 1.800.747.1762 • www.fantech.net

Canada 50 Kanalfakt Way • Bouctouche, NB E4S 3M5 • 1.800.565.3548 • www.fantech.net

Fantech, reserves the right to modify, at any time and without notice, any or all of its products' features, designs, components and specifications to maintain their technological leadership position.

