

Model No. GBC1849W-U (ASDA Spec Code: 16B.02.18.027)

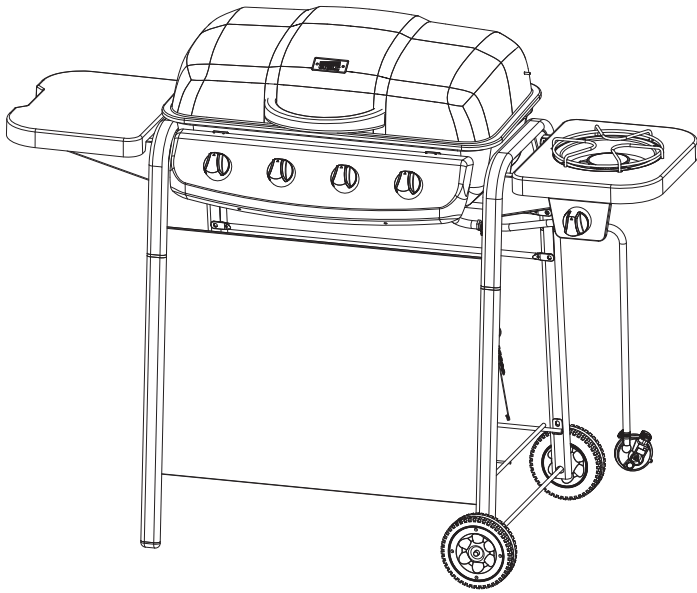

Table of Contents

Important Safeguards	Page 2
Specifications	5
Expanded View & Hardware	6 & 7
Assembly Instructions	8
Installing Gas Cylinder	12
Gas Regulator	12 & 13
Operating Instructions	14
Cleaning and Care	17
Refund Information	18
Customer Services Information	18
Contact Us	18
Troubleshooting	19

This instruction booklet contains important safety information. Please read and keep for future reference.

If you sell or give this product to someone else, make sure this manual accompanies this product.

If you need help, have missing or damaged parts, or have any questions, please call us toll free at 0800-9520101 or e-mail us at asdSERVICE@revoace.com.

This grill is supplied with a 27 mm clip on propane regulator suitable for use with propane patio gas cylinders.



WARNING



FOR YOUR SAFETY:

1. Do NOT store or use gasoline or other flammable liquids or vapors in the vicinity of this or any other appliance.
2. When cooking with oil/grease, do NOT allow the oil/grease to exceed 350°F (176.5°C). Do NOT store or use extra cooking oil in the vicinity of this or any other appliance.



DANGER



If you smell gas -

1. Shut off gas to appliance.
2. Extinguish any open flame.
3. Open lid.
4. If odor continues, keep away from the appliance and immediately call your gas supplier or your fire department.



CAUTION



FOR YOUR SAFETY:

Do not use spirit, petrol or comparable fluids for lighting or re-lighting!

Read the following instructions carefully and be sure your barbecue is properly installed, assembled and cared for. Failure to follow these instructions may result in serious bodily injury and/or property damage.



DANGER



FOR YOUR SAFETY:

**For Outdoor Use Only (Outside any enclosure).
Never operate this appliance unattended.
Keep children and pets away.**



ATTENTION



This barbecue will become very hot, do not move it during operation.

Important Safeguards Warning



- ▲ Use outdoor only.
- ▲ Read the instructions before using the appliance.
- ▲ **WARNING:** Accessible parts may be very hot. Keep young children away.
- ▲ This appliance must be kept away from flammable materials during use.
- ▲ Do not move the appliance during use.
- ▲ Turn off the gas supply at the gas cylinder after use.
- ▲ Do not modify the appliance.
- ▲ Gas cylinder can't be used or stored underneath the fire bowl or in the grill cabinet
- ▲ This grill is for outdoor use only, and should not be used in a building, garage or any other enclosed area.
- ▲ Do NOT operate, light or use this appliance within 3.05 m of walls, structures or buildings.
- ▲ It is important that there are no overhead obstructions and that there is a minimum distance of 1 m from the side or rear of the appliance. It is important that the ventilation openings of the appliance are not obstructed. The barbecue must be used on a level, stable surface. The appliance should be protected from direct draughts and shall be positioned or protected against direct penetration by any trickling water (e.g. rain).
- ▲ For residential use only. This grill is NOT for commercial use.
- ▲ This grill is NOT intended for and should never be used as a heater. TOXIC fumes can accumulate and cause asphyxiation.
- ▲ Do NOT use grill for indoor cooking. TOXIC carbon monoxide fumes can accumulate and cause asphyxiation.
- ▲ The grill, from the factory, is for use with liquid propane (LP) gas only. The conversion to or attempted use of natural gas in this LP gas grill is dangerous, may cause bodily harm and will void your warranty.
- ▲ Never use charcoal, lighter fluid, lava rocks, gasoline, kerosene or alcohol in the "gas" side of the grill.
- ▲ Apartment/Flat Dwellers: Check with management to learn the requirements and fire codes for using a LP gas grill in your apartment complex. If allowed, use outside on the ground floor with a 3.05 m clearance from any structure. Do NOT use on or under balconies.
- ▲ The conversion to or attempted use of natural gas is dangerous.
- ▲ The gas cylinder, regulator and hose must be C E approved.
- ▲ Regulator and hose:
 - a. These items are supplied with the barbecue, but replacements are available from your equipment retailer or an authorized LPG gas stockist. Use only regulators and hose approved for Gas at the above pressures. The life expectancy of the regulator is estimated as 10 years. It is recommended that the regulator is changed within 10 years of the date of manufacture.
 - b. The use of the wrong regulator or hose is unsafe; always check that you have the correct items before operating the barbecue.
 - c. The hose used conforms to the relevant standards for the country of use. The length of the hose must be 1.5 meters (maximum). Worn or damaged hose must be replaced. Ensure that the hose is not obstructed, kinked, or in contact with any part of the barbecue other than at its connection.
- ▲ This appliance is only suitable for use with low-pressure butane or propane gas or LPG mixtures, fitted with the appropriate low-pressure regulator via a flexible hose. This barbecue is supplied with a 27mm propane regulator which operates at 37 mbar. If you wish to use butane use a suitable 28-30 mbar butane regulator certified to BS EN 16129. Please consult your LPG dealer for information regarding a suitable regulator for the gas cylinder.
- ▲ Gas Cylinder:
 - a. The gas cylinder should not be dropped or handled roughly! If the appliance is not in use, the cylinder must be disconnected. Replace the protective cap on the cylinder after disconnecting the cylinder from the appliance.
 - b. Cylinders must be stored outdoors in an upright position and out of the reach of children. The cylinder must never be stored where temperatures can reach over 50°. Do not store the cylinder near flames, pilot lights or other sources of ignition. DO NOT SMOKE.
- ▲ Your barbecue can be used on gas cylinders between 11 kg and 15kg. Your barbecue will perform better if propane or LPG mixtures are used.
- ▲ The position of the connection flexible tube so as



Important Safeguards Warning



- ▲ to ensure that it is not subjected to twisting.
- ▲ Never use a gas cylinder with a damaged body, valve, collar or footing.
- ▲ Dented or rusted gas cylinders may be hazardous and should be checked by your gas supplier prior to use.
- ▲ The LP gas cylinder should not be dropped or handled roughly.
- ▲ Do NOT insert any tool or foreign object into the valve outlet or safety relief valve. You may damage the valve and cause a leak. Leaking propane may result in an explosion, fire, severe personal injury or death.
- ▲ Do NOT block holes in sides or back of grill.
- ▲ Never keep a gas cylinder in a hot car or trunk. Heat will cause the gas pressure to increase, which may open the relief valve and allow gas to escape.
- ▲ If grill is not in use, the gas must be turned off at the supply cylinder and disconnected.
- ▲ Do NOT store a spare gas cylinder under or near this appliance.
- ▲ Never attempt to attach this grill to the self-contained gas system of a camper trailer, motor home or house.
- ▲ Your grill has been checked at all factory connections for leaks. Recheck all connections as described in the "Operating Instructions" section, as shipping can loosen connections.
- ▲ Check for leaks even if your unit was assembled for you by someone else.
- ▲ Do NOT operate if a gas leak is present. Gas leaks may cause a fire or explosion.
- ▲ You must follow all instructions in "Checking for Leaks" section before operating. To prevent fire or explosion hazard when testing for a leak:
 - a. Always perform a leak test before lighting the grill and each time the cylinder is connected for use.
 - b. No smoking. Do NOT use or permit sources of ignition in the area while conducting a leak test.
 - c. Conduct the leak test outdoors in a well-ventilated area.
 - d. Do NOT use matches, lighters, or a flame to check for leaks.
 - e. The use of alcohol, prescription or non-prescription drugs may impair the consumer's ability to properly assemble or safely operate the appliance.
- f. Strong odors, colds, sinus congestion, etc. may prevent the detection of propane. Use caution and common sense when testing for leaks.
- g. Do NOT use grill until any and all leaks are corrected. If you are unable to stop a leak, disconnect the LP gas supply. Call a gas appliance serviceman or your local LP gas supplier.
- ▲ This grill is designed to operate at an inlet pressure of: 11 inches water column.
- ▲ Do NOT store or use gasoline or other flammable liquids or vapors within 7.62 m of this appliance.
- ▲ Do NOT use in an explosive atmosphere. Keep grill area clear and free from combustible materials, gasoline and other flammable vapors and liquids.
- ▲ Minimum clearance from sides and back of unit to combustible construction is 91.4 cm. Do NOT use this appliance under any type of overhang or roof.
- ▲ It is essential to keep the grill's valve compartment, burners and circulating air passages clean.
- ▲ Inspect grill before each use.
- ▲ Do NOT alter grill in any manner. Any alteration will void your warranty.
- ▲ Parts sealed by the manufacturer or his agent must not be altered by the user. No modifications should be made to any part of this barbecue and repairs and maintenance should only be carried out by a CORGI / Gas Safe registered service engineer.
- ▲ Do NOT use the grill unless it is COMPLETELY assembled and all parts are securely fastened and tightened.
- ▲ Do NOT build this model of grill in any built-in or slide-in construction. Ignoring this warning could cause a fire or an explosion that can damage property and cause serious bodily injury or death.
- ▲ This grill should be thoroughly cleaned and inspected on a regular basis.
- ▲ Clean and inspect the hose before each use of the appliance. If there is evidence of abrasion, wear, cuts or leaks, the hose must be replaced prior to operation.
- ▲ Use only the regulator and hose assembly provided.
- ▲ The parts contained in the package have been sealed by the manufacturer must not be altered in any way.

Important Safeguards Warning

- ⚠ Do NOT operate this appliance without reading “Operating Instructions” in this manual.
- ⚠ Do NOT touch metal parts of grill until they have completely cooled to avoid burns, unless you are wearing protective gear (pot holders, gloves, BBQ mitts, etc.).
- ⚠ Do NOT install or use in or on boats or recreational vehicles.
- ⚠ When cooking, fire extinguishing materials should be readily accessible. In the event of an oil/grease fire, do NOT attempt to extinguish with water. Use type BC dry chemical fire extinguisher or smother with dirt, sand or baking soda.
- ⚠ Do NOT use grill in high winds.
- ⚠ Never lean over the grill when lighting.
- ⚠ Do NOT leave a lit grill unattended. Keep children and pets away from grill at all times.
- ⚠ Do NOT leave grill unattended while preheating or burning off food residue on high. If grill has not been cleaned, a grease fire can occur that may damage the product.
- ⚠ Never light the appliance with the HOOD in the closed position.
- ⚠ Do NOT place empty cooking vessels on the appliance while in operation.
- ⚠ Use caution when placing anything on the grill while the appliance is in operation.
- ⚠ Do NOT attempt to move grill when in use. Allow the grill to cool before moving or storing.
- ⚠ Gas cylinder must be properly disconnected and removed prior to moving this grill.
- ⚠ Storage of grill indoors is permissible only if the cylinder is disconnected, removed from the grill and properly stored outdoors.
- ⚠ Always open grill lid carefully and slowly as heat and steam trapped within grill can cause severe burns.
- ⚠ Do NOT attempt to disconnect the gas regulator from the cylinder or any gas fitting while the grill is in use.
- ⚠ Always place your grill on a hard, non-combustible, level surface. An asphalt or blacktop surface may not be acceptable for this purpose.
- ⚠ Move gas hoses as far away as possible from hot surfaces and dripping hot grease.
- ⚠ Keep all electrical cords away from a hot grill.
- ⚠ After a period of storage and/or nonuse, check for leaks, burner obstructions and inspect for any abrasion, wear or cuts to the hose.
- ⚠ Failure to open lid while igniting the grill’s burners, or not waiting 5 minutes to allow the gas to clear if the grill does not light, may result in an explosive flare-up.
- ⚠ Never operate grill without its heat plates installed.
- ⚠ Always use a meat thermometer to ensure food is cooked to a safe temperature.
- ⚠ Use protective gloves when assembling this product.
- ⚠ Do NOT force parts together as this can result in personal injury or damage to the product.
- ⚠ Never cover entire cooking area with aluminum foil.
- ⚠ Death, serious injury or damage to property may occur if the above is not followed exactly.

Specifications

Approvals	CE 0359-17 Pin: 0359CR01461
-----------	--------------------------------

Barbecue

Appliance Category	I ₃₊
Weight	21 kg / 46.3 lbs
Dimensions (L x W x H)	138.6cm x 61cm x 106.4cm
Grilling surface (L x W)	68.0cm x 33.2cm
Load weight	Max. 6 kg.
Side shelf	Max. 6 kg.
Side burner table	Max. 6 kg.

Gas System

Heat quantity	Main burner	10.55 kW (36,000 BTU)
	Side burner	2.93 kW (10,000 BTU)
Mass flow rate		13.48 kW (978 g/h)
Gas type	Butane	Propane
Pressure regulator		Preset and CE – approved pressure regulator
	Flow rate	Max. 1.5 kg/h
	Operating pressure	28-30 mbar Butane / 37 mbar Propane
Gas cylinder		Standard gas cylinder with a fill weight of 11 or 15 kg
Gas hose		CE approved hose (Max 1.5 m)
Ignition type		Integrated ignition
Flame regulation		Infinitely adjustable 1 - max.
Nozzle diameter		0.80mm main / 0.84mm side

Expanded View

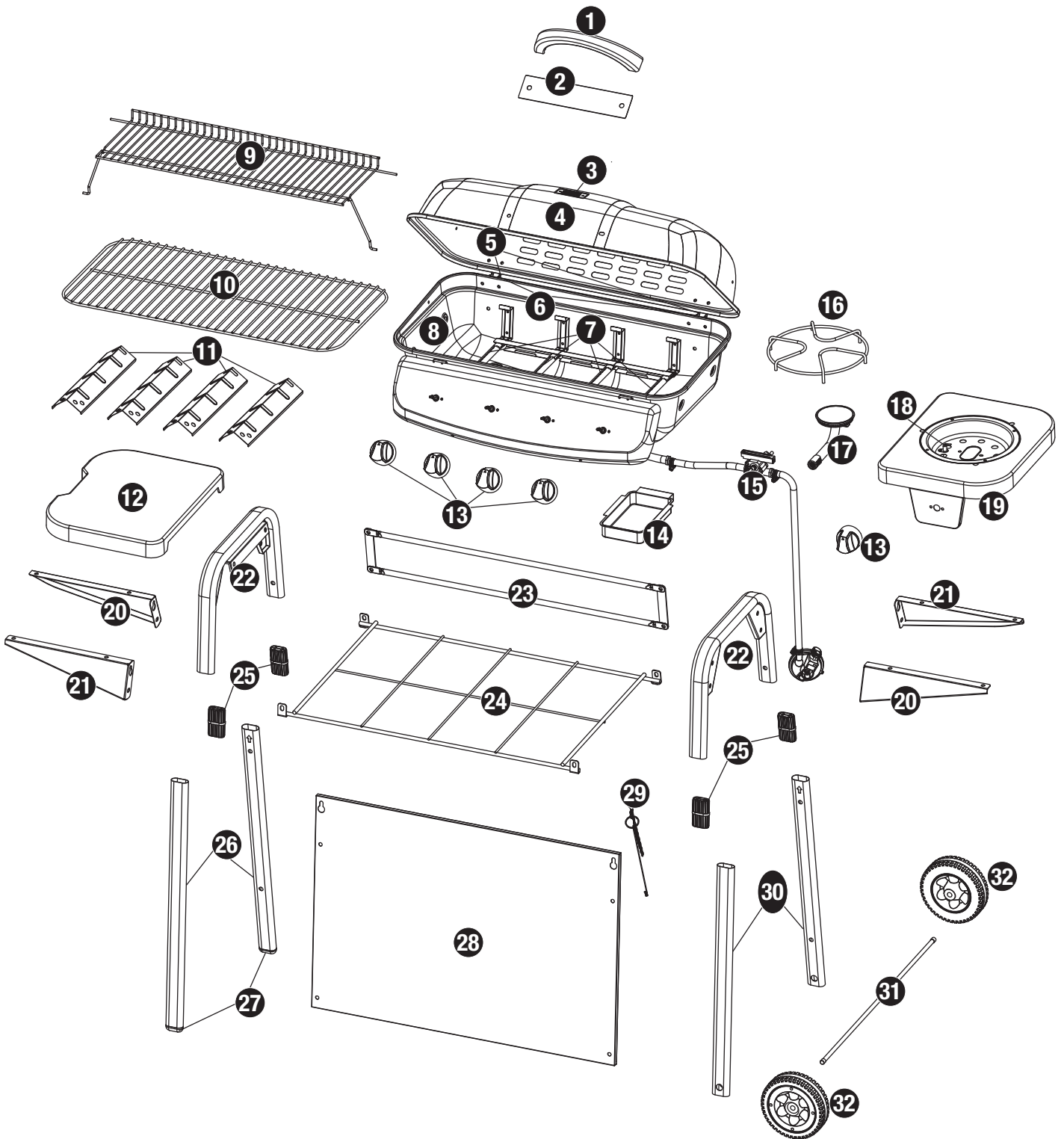

Parts List

1	Lid Handle	G1849-010	18	Side Burner Electrode*	B0406-000
2	Handle Shield	G1849-020	19	Right Side Shelf	G1849-080
3	Brand Plate*	B0109-LBA	20	Shelf Support B (2)	G1849-090
4	Lid*	G1849-070	21	Shelf Support A (2)	G1849-100
5	Top Hinge(2)*	G1849-050	22	Upper Cart Frame (2)	G1849-110
6	Bottom Hinge(2)*	G1716-030	23	Rear Cart Frame	G1849-120
7	Burner (4)*	G1849-040	24	Bottom Grid	G1849-130
8	Grill Body Assembly*	G1849-050	25	Leg Connector	G1849-140
9	Warming Rack	G1846-060	26	Left Leg (4)	G1849-150
10	Cooking Grid	G1846-070	27	Foot (2)*	G1849-160
11	Heat Plate (4)	G1716-080	28	Front Panel	G1849-170
12	Left Side Shelf	G1849-060	29	Light Hook	B0223-D00
13	Control Knob (5)	G1703-210	30	Right Leg (2)	G1849-180
14	Grease Cup	B0219-H00	31	Axis	G1849-190
15	Regulator/Hose Assembly*	B0308-D20	32	Wheel (2)	B0302-E11
16	Side Burner Grid	B0404-C00			
17	Side Burner	G1849-070			

* Pre-assembled

Hardware

A	Screw	M4x10 Nickel Plated Phillips Truss Head	4 pcs
B	Screw	M6x15 Nickel Plated Phillips Truss Head	32 pcs
C	Nut	M10 Steel	2 pcs
D	Wing Nut	M6 Nickel Plated	2 pcs
E	Washer	ø6.4 Aluminum	4 pcs
F	Lock Washer	ø22 Nickel Plated	2 pcs
G	Lock Washer	ø6 Nickel Plated	2 pcs

Tools Required for Assembly (Included)

#2 Phillips Head Screwdriver 1 pc

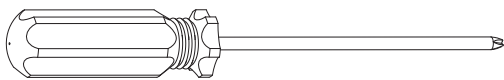

M10 Wrench 2 pcs



Assembly Instructions

1 DO NOT RETURN TO PLACE OF PURCHASE

Assembly Tips:

1. Select an area where you will assemble this product. To protect components, choose a smooth surface that's free of cracks or openings.
2. Spread out all parts.
3. Tighten all hardware connections by hand first. Then, before completing each step, go back and fully tighten all hardware. Be careful not to over-tighten. That could damage surfaces or strip threads.
4. For best results, complete each step in the order presented.

To complete assembly you will need:

- (1) Leak detection solution (instructions on how to make the solution are included in the "Operating Instructions" section of this manual) (not included).
- (1) precision-filled gas cylinder between 11kg and 15kg. Your barbecue will perform better if propane or LPG mixtures are used. (not included).

Typical assembly is approximately one hour.

2 Attach Upper Cart Frames, Leg Connectors and Legs

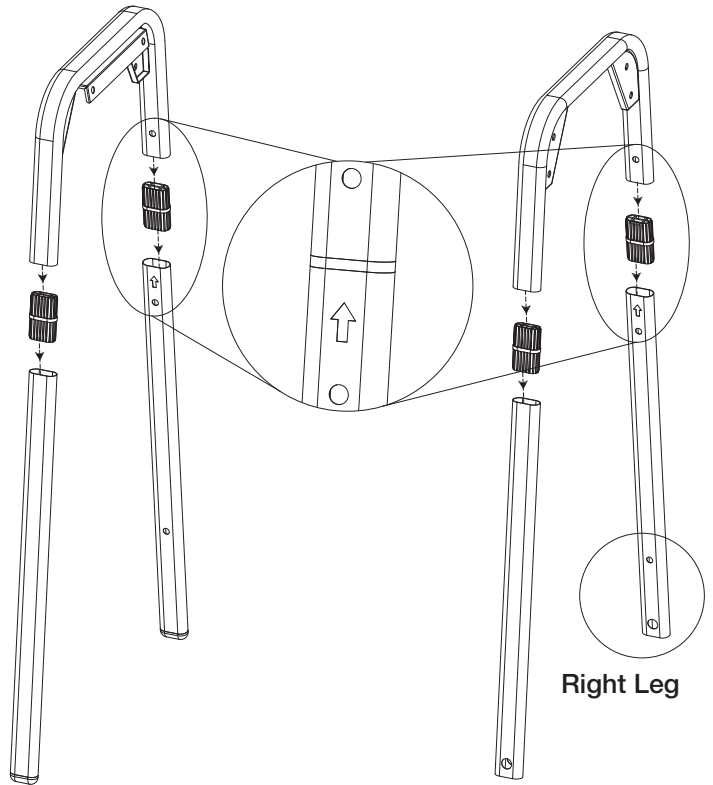

3 Attach Right Cart Frame

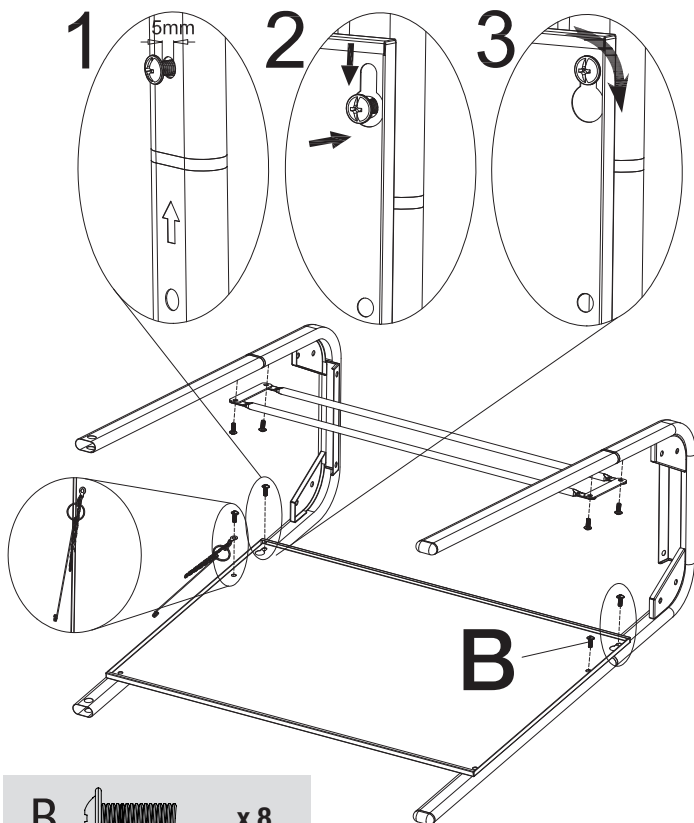

4 Attach Bottom Grid

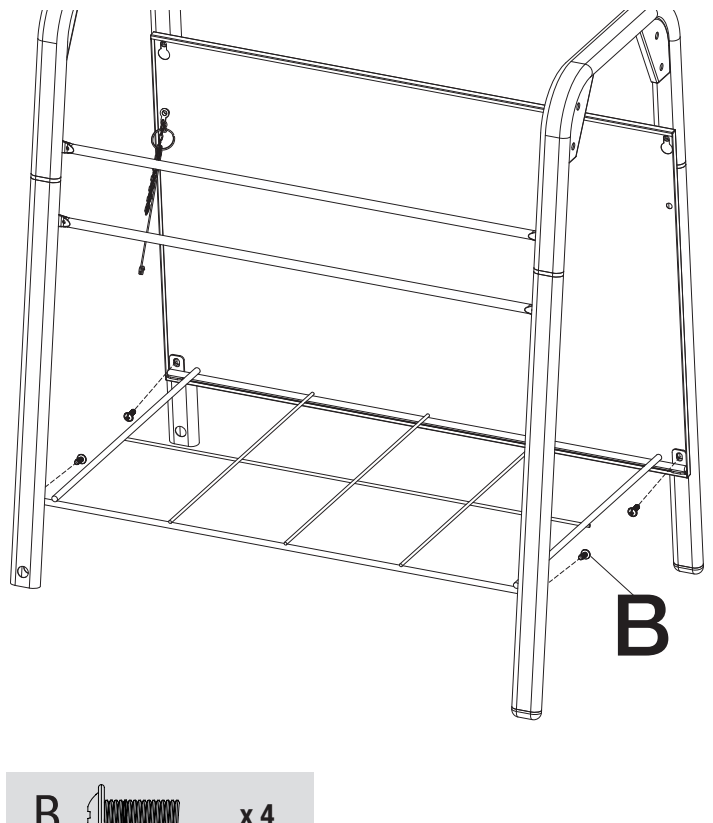

5 Attach Axis and Wheels

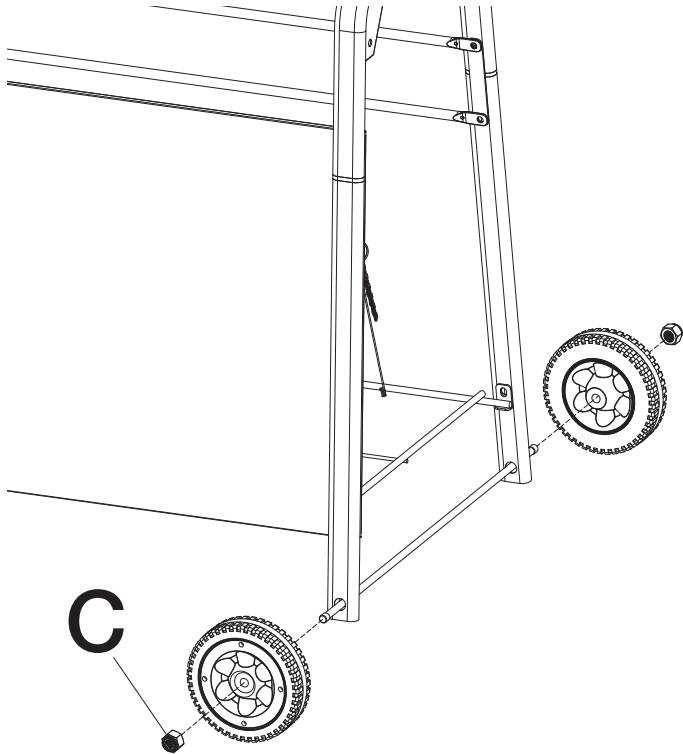

6 Attach Lid and Grill Body Assembly

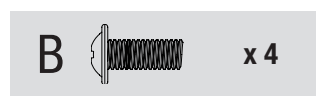
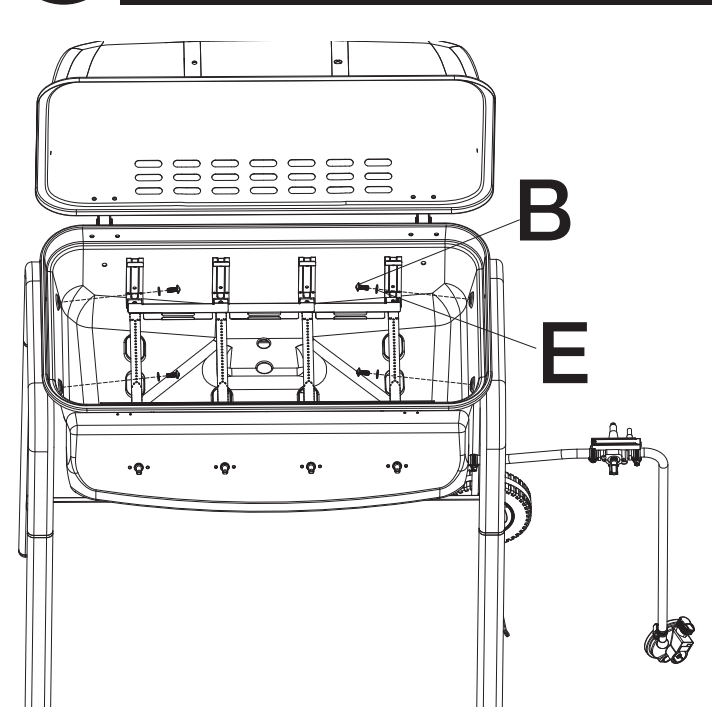

7 Attach Axle, Wheels and Control Knobs

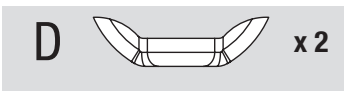
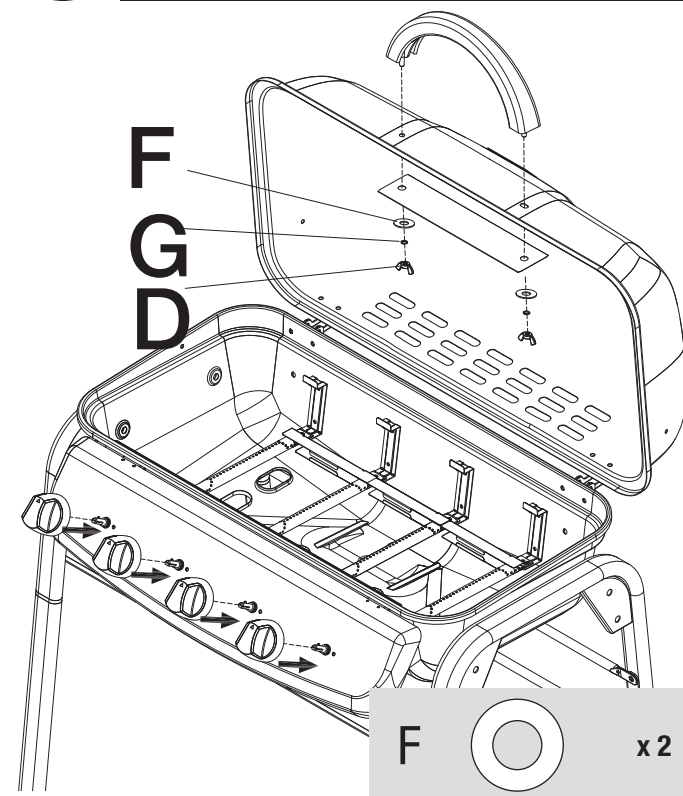

8 Attach Shelf Support A&B

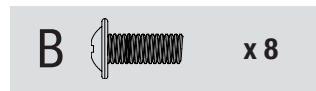
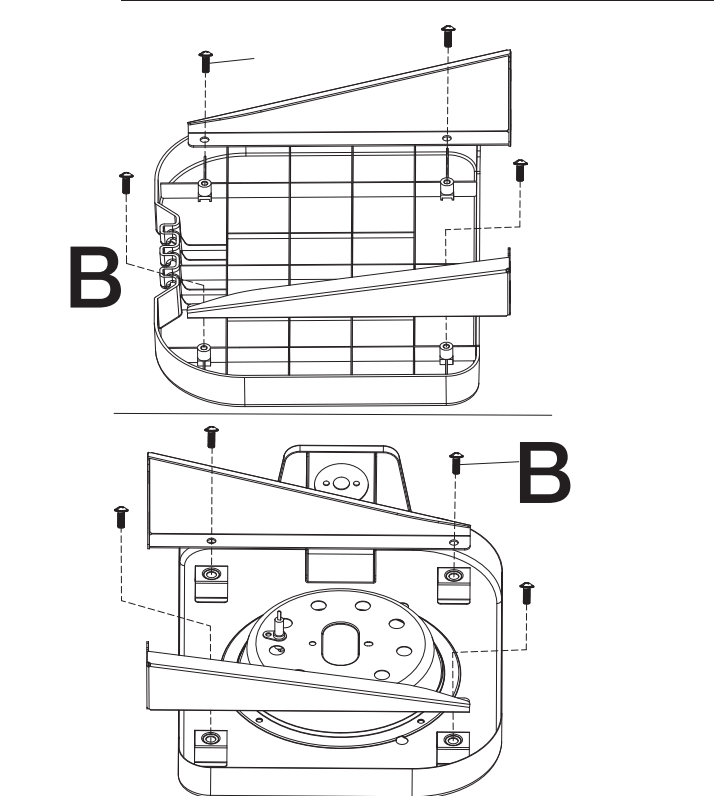

9 Attach Left Side Shelf

Note: Leave 5 mm of bolt threads exposed.

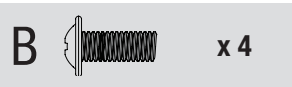
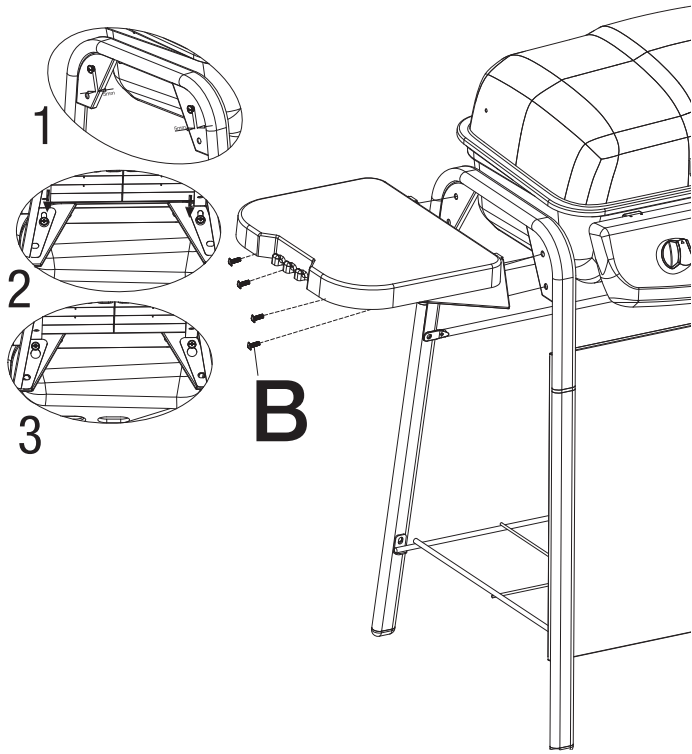

10 Attach Right Side Shelf

Note: Leave 5 mm of bolt threads exposed.

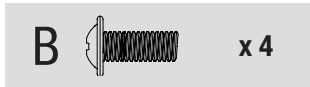
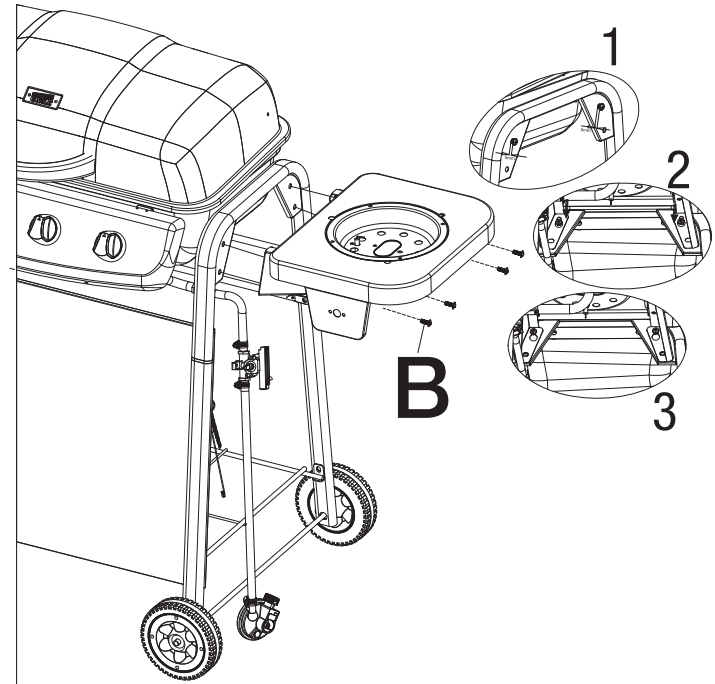

11 Attach Regulator/Hose Assembly

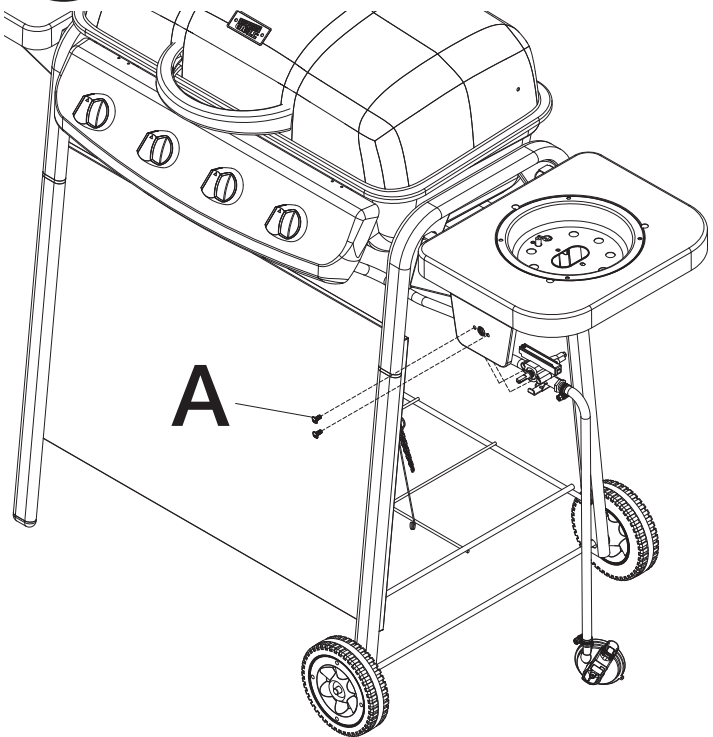

12 Attach Side Burner, Side Burner Grid and Side Control Knob

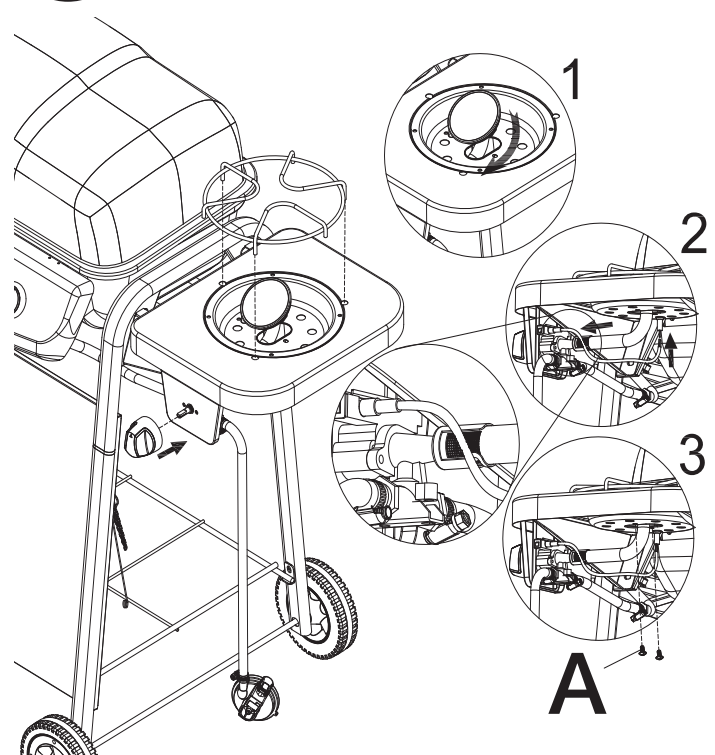

13

Insert Heat Plate and Cooking Grid

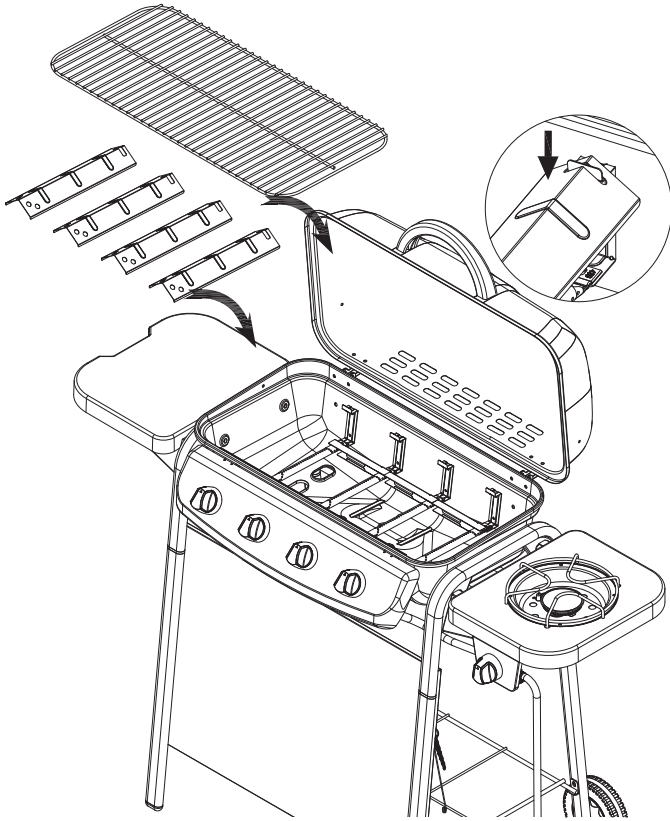

14

Insert Warming Rack

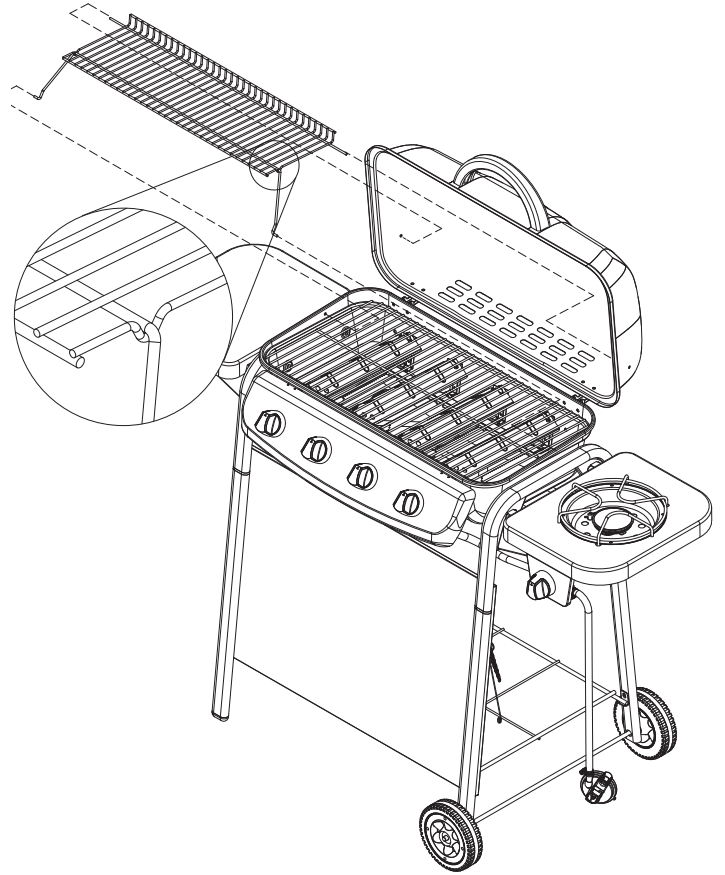

Installing LP Gas Cylinder

To operate you will need a precision-filled gas cylinder between 11kg and 15kg. Your barbecue is supplied with a regulator and hose suitable for use with a propane patio gas cylinder with a 27mm connection.

Place Gas Cylinder

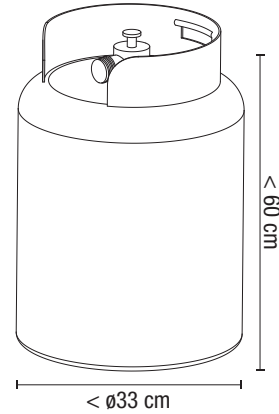
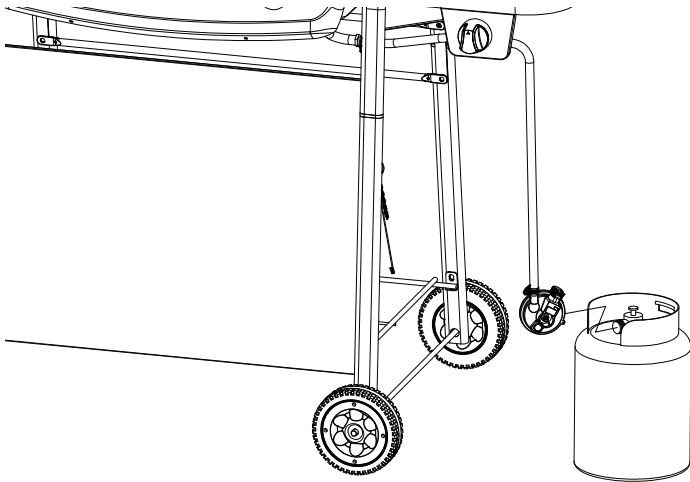

Gas Regulator

Read thoroughly before use.

Figure A

Figure B

Gas Regulator Parts

- | | |
|---|--------------------------------|
| 1 | Regulator Identification Label |
| 2 | Regulator Assembly |
| 3 | Regulation Rubber Hose |
| 4 | Hose Clamp |
| 5 | Regulator Valve Handle |

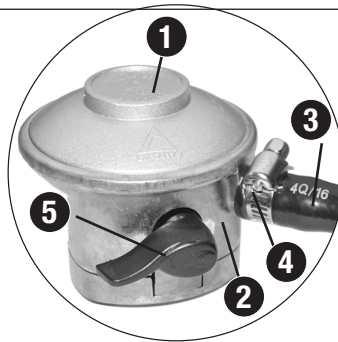

Figure C

Connecting and Operating Conditions

The regulator supplied is a 27mm "Snap on compact" propane regulator operating at 37 mbar pressure.

The "Snap on compact" is a regulator designed to supply gas to a consuming appliance at a pressure and capacity as indicated on the regulator identification label.

The "Snap on compact" can be fitted to any cylinders equipped with automatic valves having a diameter as indicated on the regulator.

- ▲ **CAUTION: The gas cylinder must always be used in the upright position.**
- ▲ **CAUTION: Whenever used outdoors, the "snap on compact" should be protected against rain.**
- ▲ **CAUTION: Never use a flame to look for leaks, do it using a soap solution.**
- ▲ **CAUTION: In case of any difficulties or problems, close the gas supply immediately and contact your dealer.**
- ▲ **CAUTION: Never move or displace the gas cylinder when it is on.**
- ▲ **CAUTION: Gas cylinder must be properly disconnected and removed prior to moving this grill.**
- ▲ **CAUTION: Never attempt to disconnect regulator when the regulator valve is not in the "OFF" position.**
- ▲ **CAUTION: If you are unable to turn the regulator handle to the "ON" position, your regulator is not properly connected. Do not force the handle to open. Remove the regulator and repeat "Connect Gas Cylinder" section.**



Figure D



Gas Regulator (continued)

Fitting the Hose

Before connecting the “Snap on compact” to a cylinder valve:

1. Connect regulation rubber hose to the barbed stem on the regulator.
Tip: Lubricate the barbed stem with water to help connect the regulator hose to the regulator.
2. Use a hose clamp to secure the regulation rubber hose to the regulator.

Connect Gas Cylinder

1. Make sure control knobs are ● (OFF) position (Figure 3).
2. The regulator rubber hose and regulator are properly and securely connected.
3. The regulator valve handle is in the “OFF” position. (Figure C).
4. Remove the seal cap from the automatic valve on the gas cylinder.
5. Place regulator onto the automatic valve on the gas cylinder. Push down firmly and vertically. (Figure B)
6. You should hear a “click” sound when the regulator is securely latched.

▲ CAUTION: Never attempt to connect regulator when the regulator valve is not in the “OFF” position.

Figure E



Operating Regulator

1. To turn regulator ON, turn the regulator valve handle clockwise into the the “ON” position. (Figure D)
2. To turn regulator OFF, turn the regulator valve handle counterclockwise into the the “OFF” position. (Figure C)

Disconnecting Gas Cylinder

1. Make sure control knobs are ● (OFF) position (Figure 3).
2. Turn the regulator valve handle to the “OFF” position (Figure C).
3. Push down the regulator valve handle firmly, then pull the regulator clamp and regulator upwards (Figure E).

Operation of Excess Flow Check Device

The regulator can be fitted with a safety device designed to automatically limit the gas escape in case of gas leak, which prevents the gas from reaching the grill. The marking “excess flow” on the regulator identification label means that the regulator is provided with this option.

The “excess flow device” is likely to activate under the following condition.

- Normal operating conditions.
Consumption of the gas fired appliance is higher than the regulator flow capacity. In such case, you should contact your installer.
- In case of pipe being torn off, proceed as follows:
 1. Disconnect the regulator per the “Disconnect Gas Cylinder” section.
 2. Re-fit the hose correctly.
 3. Connect the regulator per the “Connect Gas Cylinder” section.
 4. Turn the regulator valve to the “ON” position.
 5. Wait a few seconds (20 seconds) before restarting the system.

▲ CAUTION: If you are unable to turn the regulator handle to the “ON” position, your regulator is not properly connected. Do not force the handle to open. Remove the regulator and repeat “Connect Gas Cylinder” section.

▲ WARNING: The regulator is NEVER to be left on the cylinder without its being connected to the grill, as the tear-off proof safety is not designed to ensure the operation of the cylinder valve.

To guarantee a proper operation of the excess flow device, the pipe that supplies gas to the consuming appliance shall be no more than 2 meters in length.

Operating Instructions

Checking for Leaks

Burner Connections

1. Make sure the regulator hose and valve connections are securely fastened to the burner and the tank.
2. Visually check the connection between the burner/venturi tube and orifice.
3. Make sure the burner/venturi tube fits over the orifice.

⚠ WARNING: Failure to inspect this connection or follow these instructions could cause a fire or an explosion which can cause death, serious bodily injury or damage to property.

4. Please refer to diagram for proper installation (Figures 1, 2 and 4).
5. If the burner/venturi tube does not rest flush to the orifice, as shown, please contact 0800 9520101 for assistance.

Tank/Gas Line Connection

1. Make 2-3 oz. of leak detection solution by mixing one part liquid dishwashing soap with three parts water.
2. Make sure control knobs are in the ● (OFF) position (Figure 3).
3. Connect gas tank per “Installing Gas Cylinder” section.
4. To turn regulator ON, turn the regulator valve counterclockwise into the the “ON” position. (Figure D)
5. Spoon several drops of solution, or use a squirt bottle, at all “X” locations (Figures 1, 2 and 4).
 - a. If any bubbles appear, turn the regulator valve clockwise into the the “OFF” position. (Figure C).
 - b. If you continue to see bubbles after several attempts, turn gas cylinder valve to “OFF” and disconnect gas cylinder, per “Disconnect Gas Cylinder” section. Contact 0800 9520101 for assistance.
 - c. If no bubbles appear after one minute, turn gas cylinder valve to “CLOSED,” wipe away solution and proceed.

Figure 1: Main Burners

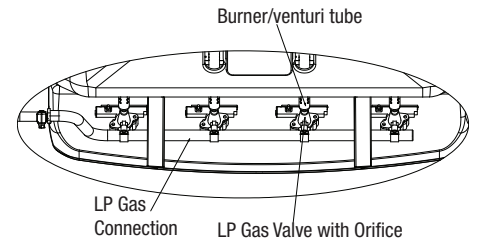

Figure 2: Side Burner

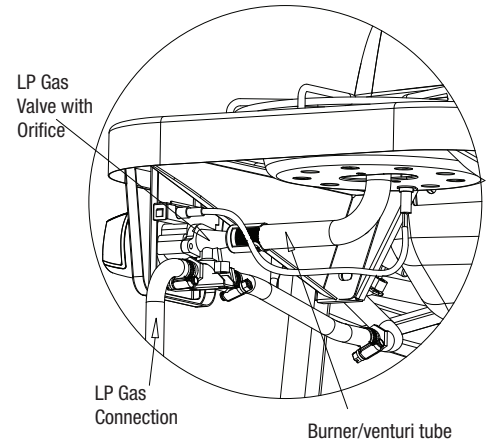

Figure 3

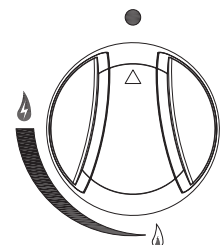

Figure 4

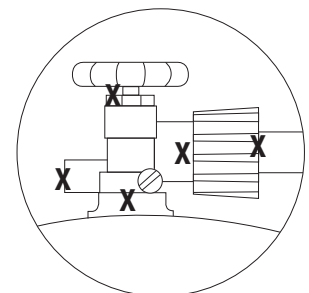
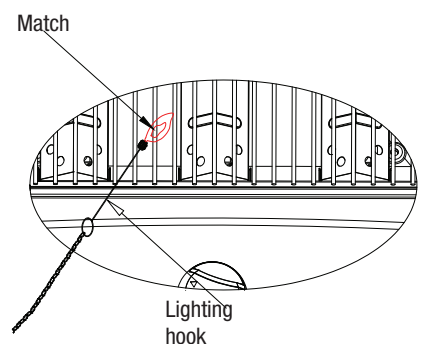

Figure 5



Operating Main Burners

First Use

1. Make sure all labels, packaging and protective films have been removed from the grill.
2. Remove manufacturing oils before cooking on this grill for the first time by operating the grill for at least 15 minutes on 🔥 (HIGH) with the lid closed. This will “heat clean” the internal parts and dissipate odors.

Lighting

- ⚠ CAUTION: Keep outdoor gas cooking appliance area clear and free from combustible materials, gasoline and other flammable vapors and liquids.**
- ⚠ CAUTION: Do NOT obstruct the flow of combustion and ventilation air.**
- ⚠ CAUTION: Check and clean burner/venturi tubes for insects and insect nests. A clogged tube can lead to a fire.**
- ⚠ CAUTION: Attempting to light the burner with the lid closed may cause an explosion.**

1. Open lid.
2. Check for obstructions of airflow to the burners. Spiders, insects and webs can clog the burner/venturi tube. A clogged burner tube can lead to a fire.
3. All control knobs must be in the ● (OFF) position (Figure 3).
4. Connect gas cylinder per “Installing Gas cylinder” section.
5. To turn regulator ON, turn the regulator valve counterclockwise into the the “ON” position. (Figure D).
6. Push and turn any control knob to 🔥 (HIGH). The burner should light. If it does not, repeat up to three times.

Operating Instructions (continued)

7. If ignition does not occur in 5 seconds, turn burner control knob ● (OFF), wait 5 minutes, and repeat lighting procedure.
8. If igniter does not light burner, use a lit match secured with the lighting rod (included with grill) to light burners. Access the burners through the cooking grid and heat plates. Position lit match near side of burner (Figure 5).

Important: Always use the lighting rod (included) when lighting burners with a match.

9. After lighting, observe the burner flame. Make sure all burner ports are lit and flame height matches illustration (Figure 6).

Note: Each burner lights independently - repeat steps 5-9 for the other burners.

Figure 6

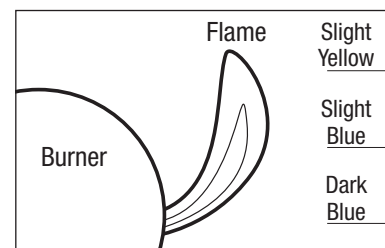

⚠ CAUTION: If you are unable to turn the regulator handle to the “ON” position, your regulator is not properly connected. Do not force the handle to open. Remove the regulator and repeat “Connect Gas Cylinder” section

⚠ CAUTION: If burner flame goes out during operation, immediately turn the control knobs to the ● (OFF) position, Gas cylinder valve “OFF” and open lid to let the gas clear for 5 minutes before re-lighting.

Turning Off

1. Turn gas cylinder valve to “CLOSED.”
2. Turn all control knobs clockwise to the ● (OFF) position. Note: A “poof” sound is normal as the last of the LP gas is burned.
3. Disconnect gas cylinder per “Disconnecting Gas Cylinder” section.

Controlling Flare-ups

1. If a grease fire develops, turn control knobs to the ● (OFF) position and Gas cylinder valve “CLOSED.” Do NOT use water on a grease fire. This can cause the grease to splatter and could result in serious burns, bodily harm or other damage.
2. Do NOT leave grill unattended while preheating or burning off food residue on 🔥 (HIGH). If grill has not been cleaned, a grease fire can occur.

Flare-ups are a part of cooking meats on a grill and add to the unique flavor of grilling.

Excessive flare-ups can over-cook your food and be dangerous.

Important: Excessive flare-ups result from the build-up of grease in the bottom of your grill.

If a grease fire occurs, close the lid **AND** turn the control knob(s) to ● (OFF) until the grease burns out. Be careful when opening the lid as sudden flare-ups may occur.

If excessive flare-ups occur, **do NOT** pour water onto the flames.

Minimize Flare-ups:

1. Trim excess fat from meats prior to cooking.
2. Cook high fat content meats on 🔥 (LOW) setting or indirectly.
3. Ensure that your grill is on a hard, level, non-combustible surface and the grease is allowed to drain into grease receptacle.

Operating Side Burner

Note: Side burner can be used while main burners are operating.
Never use side burner as a grill.

⚠ CAUTION: Maximum weight for side burner and side shelf is 15 kgs.

⚠ CAUTION: Using pots larger than 6 quarts or 240 mm diameter in capacity could exceed weight limit of the side burner shelf, resulting in failure of grill cart components.

⚠ CAUTION: Do NOT lean on the side burner shelf.

⚠ CAUTION: Attempting to light the burner with the lid closed may cause an explosion.

⚠ WARNING: When cooking, fire extinguishing materials should be readily accessible. In the event of an oil/grease fire, use type BC dry chemical fire extinguisher or smother with dirt, sand or baking soda. Do NOT attempt to extinguish with water.

Operating Instructions (continued)

Lighting

1. Open lid.
2. Check for obstructions of airflow to the burners. Spiders, insects and webs can clog the burner/venturi tube. A clogged burner tube can lead to a fire.
3. Control knob must be in the ● (OFF) position (Figure 3).
4. Connect gas cylinder per “Installing Gas cylinder” section.
5. To turn regulator ON, turn the regulator valve handle clockwise into the “ON” position. (Figure D)
6. Push and turn control knob to 🔥 (HIGH). The burner should light. If not, repeat up to three times.
7. If ignition does not occur in 5 seconds, turn burner control knob ● (OFF), wait 5 minutes and repeat lighting procedure.
8. If igniter does not light burner, use a lit match secured with the lighting rod (included with grill) to light burners. Position the lit match near side of the burner (Figure 7).

Important: Always use the lighting rod (included) when lighting burner with a match.

9. After lighting, observe the burner flame. Make sure all burner ports are lit and flame height matches illustration (Figure 6).

⚠ CAUTION: If burner flame goes out during operation, immediately turn the control knob to the ● (OFF) position and Gas cylinder valve “OFF” and open lid to let the gas clear for 5 minutes before re-lighting.

⚠ CAUTION: Putting out grease fires by only closing the lid is not possible.

⚠ CAUTION: If burner flame goes out during operation, immediately turn the control knob to the ● (OFF) position and Gas cylinder valve “OFF” and open lid to let the gas clear for 5 minutes before re-lighting.

Turning Off

1. Turn gas cylinder valve to “OFF.”
2. Turn control knob clockwise to the ● (OFF) position. Note: A “poof” sound is normal as the last of the LP gas is burned.
3. Disconnect gas cylinder per “Disconnecting Gas Cylinder” section.

Cooking

1. Open lid and ignite the side burner per “Lighting” instructions.
2. Adjust control knob to desired flame height.
3. Place pan on center of grid.
4. Cook and adjust temperature as needed.
5. Turn grill off per “Turning Off” instructions.

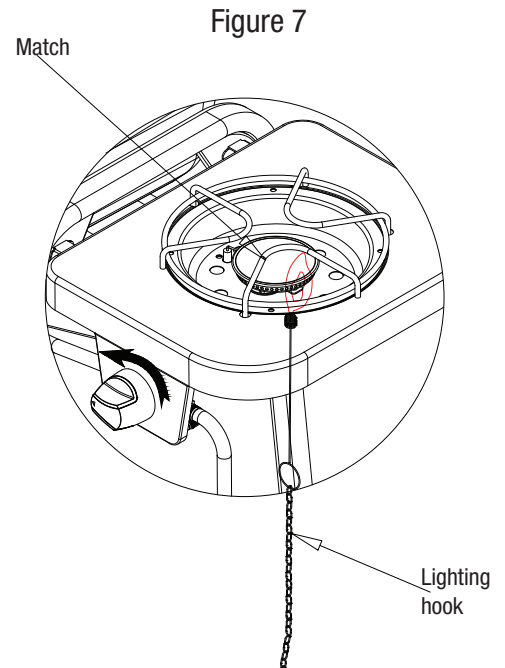

Cleaning and Care

- ⚠ **CAUTION:** All cleaning and maintenance should be done when grill is cool and with the fuel supply disconnected.
- ⚠ **CAUTION:** Do NOT clean any grill part in a self-cleaning oven. The extreme heat will damage the finish.
- ⚠ **CAUTION:** Do NOT enlarge valve orifices or burner ports when cleaning the valves or burners.
- ⚠ **NOTICE:** This grill should be thoroughly cleaned and inspected on a regular basis.
- ⚠ **NOTICE:** Abrasive cleaners will damage this product.
- ⚠ **NOTICE:** Never use oven cleaner to clean any part of grill.

Before Each Use:

1. Keep the grill area clean and free from any combustible materials, gasoline, and other flammable vapors and liquids.
2. Do NOT obstruct the flow of the combustion of LP gas and the ventilation of air.
3. Keep the ventilation opening(s) of the Gas cylinder area free and clear from debris.
4. Visually check the burner flames to make sure your grill is working properly (Figure 8).
5. See sections below for proper cleaning instructions.
6. Check for obstructions of airflow to the burners. Spiders, insects and webs can clog the burner/venturi tube. A clogged burner tube can lead to a fire.

Cleaning Surfaces

1. Wipe surfaces clean with mild dishwashing detergent or baking soda mixed with water.
2. For stubborn surfaces, use a citrus-based degreaser and a nylon scrubbing brush.
3. Rinse clean with water.
4. Allow to air dry.

Cleaning Main Burners

1. Turn the regulator valve handle counterclockwise into the the "OFF" position (Figure C).
2. Turn all control knobs clockwise to the ● (OFF) position. Note: A "poof" sound is normal as the last of the gas is burned.
3. Disconnect gas cylinder per "Disconnecting Gas Cylinder" section.
4. Remove cooking grids and heat plates.
5. Remove burners by removing the fasteners, which secure the burners to the grill bottom.
6. Lift burners up and away from gas valve orifice.
7. Disconnect wire from spark electrode.
8. Clean venturi of each burner with small bottle brush or compressed air.
9. Remove all food residue and dirt on burner surfaces.
10. Clean any clogged ports with a stiff wire (such as an opened paper clip).
11. Inspect burners for any damage (cracks or holes). If damage is found, replace with new burner(s) from manufacturer.
12. Reinstall burners, checking to insure that gas valve orifice is correctly positioned inside each burner/venturi tube. Also, check position of spark electrode.
13. Replace heat plate(s) and cooking grid(s).
14. Connect gas cylinder per "Installing Gas Cylinder" section.
15. Perform leak test per "Checking for Leaks" section.

Cleaning Side Burner

1. Turn the regulator valve handle counterclockwise into the the "OFF" position. (Figure C).
2. Turn all control knobs clockwise to the ● (OFF) position.
Note: A "poof" sound is normal as the last of the gas is burned.
3. Disconnect gas cylinder per "Disconnecting Gas Cylinder" section.
4. Remove side burner grid.
5. Remove burner by removing the screws that secure the burner to the side shelf.
6. Lift burner up and away from gas valve orifice.

Figure 8

Burner Flame Conditions

Use this chart to see if your burners need to be cleaned.

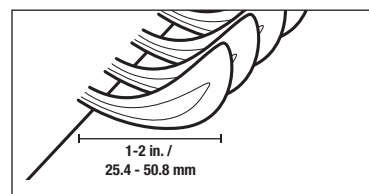

Normal: Soft blue flames with yellow tips between 1 in. - 2 in. height.

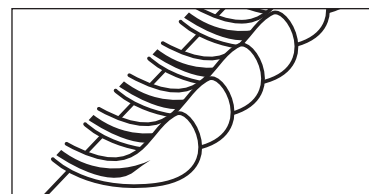

Needs cleaning: Noisy with hard blue flames.

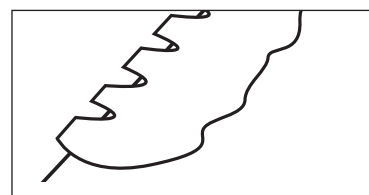

Has to be replaced: Wavy with yellow flames.

Cleaning and Care (continued)

7. Clean venturi of burner with small bottle brush or compressed air.
8. Remove all food residue and dirt on burner surface.
9. Clean any clogged ports with a stiff wire (such as an opened paper clip).
10. Inspect burner for any damage (cracks or holes). If damage is found, replace with new burner from manufacturer.
11. Reinstall burners, checking to insure that gas valve orifice is correctly positioned inside each burner/venturi tube. Also, check position of spark electrode.
12. Replace cooking grid(s).
13. Connect gas cylinder per "Installing Gas Cylinder" section.
14. Perform leak test per "Checking for Leaks" section.

Before Storing

1. Turn the regulator valve handle counterclockwise into the the "OFF" position (Figure C).
2. Turn all control knobs clockwise to the ● (OFF) position.
Note: A "poof" sound is normal as the last of the gas is burned.
3. Disconnect gas cylinder per "Disconnecting Gas Cylinder" section.
4. Clean all surfaces.
5. Lightly coat the burner(s) and cooking grid(s) with cooking oil to prevent excess rusting.
6. If storing the grill indoors, disconnect the gas cylinder per "Disconnecting Gas Cylinder" section.
7. Place the protective cap cover on the gas cylinder and store the tank outdoors in a well-ventilated area out of direct sunlight.
8. If storing the grill indoors, cover the grill and store in a cool dry place.
9. If storing the grill outdoors, cover the grill with a grill cover for protection from the weather.

Refund information

28 day no quibble refund. If you're not delighted by your product, simply bring it back within 28 days for a no quibble refund. Don't forget to include all of the item's original components and packaging along with your receipt or other proof of purchase.

Customer Services Information

If you require further information or advice regarding your product or experience any problems please contact customer services at the telephone number, e-mail or address below. When calling or writing please quote the product spec code or model number.

Product name: UniFlame 4 Burner Gas BBQ Grill

Spec Code: 16B.02.18.028 / Model number: GBC1849W-U

Contact Us

Customer Services: 0800 9520101 / asdSERVICE@revoace.com

Visit our website: www.asda.com

Copyright

© 2012 ASDA Stores Limited.

All other trademarks appearing herein are the property of there representative owners.

Specifications are subject to change without notice.

Manufactured for:

Produced for ASDA Stores Ltd, Asda House, Southbank, Great Wilson Street, Leeds, LS11 5AD

Troubleshooting

Problem	Possible Cause	Prevention/Cure
Burner will not light using igniter	Gas cylinder valve is closed	Make sure regulator is securely attached to the Gas cylinder per "Installing Gas Cylinder," then turn gas cylinder valve to "OPEN"
	Gas cylinder is low or empty	Exchange, refill or replace gas cylinder
	LP gas	<ol style="list-style-type: none"> Turn Gas cylinder valve to "CLOSED" Wait 5 minutes for gas to clear Follow "Checking for Leaks" section
	Wires or electrode covered with cooking residue	Clean wire and/or electrode with rubbing alcohol
	Electrode and burners are wet	Wipe dry with cloth
	Electrode cracked/broken - sparks at crack	Replacement part(s) may be needed
	Wire loose or disconnected	Reconnect wire or replacement part(s) may be needed
	Wire is shorting (sparking) between igniter and electrode Bad igniter	Replacement part(s) may be needed
Burner will not light with match	No gas flow	Check if gas cylinder is empty A. If empty, exchange, refill or replace gas cylinder B. If gas cylinder is not empty, refer to "Sudden drop in gas flow or reduced flame height" (see below)
	Gas cylinder is low or empty	Exchange, refill or replace Gas cylinder
	LP gas	<ol style="list-style-type: none"> Turn gas cylinder valve to "OFF" Wait 5 minutes for gas to clear Follow "Checking for Leaks" section
	Coupling nut and regulator not fully connected	Turn the coupling nut about one-half to three-quarters additional turn until solid stop. Tighten by hand only - do NOT use tools.
	Obstruction of gas flow	<ol style="list-style-type: none"> Clear burner/venturi tube Check for bent or kinked hose
	Disengagement of burner to valve	Reengage burner and valve
	Spider webs or insect nest in venturi	Clean burner/venturi tube
	Burner ports clogged or blocked	Clean burner ports
Sudden drop in gas flow or reduced flame height	Out of gas	Exchange, refill or replace gas cylinder
	Overfilling prevention device may have been activated	<ol style="list-style-type: none"> Turn control knobs to ● (OFF) Wait 30 seconds and light grill If flames are still too low, reset the overfilling prevention device: <ol style="list-style-type: none"> Turn control knob(s) ● (OFF) Turn Gas cylinder valve to "CLOSED" Disconnect regulator Turn control knobs to 🔺 (HIGH) Wait 1 minute Turn control knobs to ● (OFF) Reconnect regulator and leak check connections, being careful not to fully open valve Light grill per "Lighting" section
Irregular flame pattern, flame does not run the full length of burner	Burner ports are clogged or blocked	Clean burner ports
Flame is yellow or orange	New burner may have residual manufacturing oils	Burn grill for 15 minutes on 🔺 (HIGH) with the lid closed
	Spider webs or insect nest in venturi	Clean venturi
	Food residue, grease, etc. on burners	Clean burner
	Poor alignment of valve to burner/venturi tube	Ensure burner/venturi tube is properly engaged with valve
Flame goes out	High or gusting winds	Do not use grill in high winds
	Low on LP gas	Exchange, refill or replace gas cylinder
	Overfilling prevention device may have been activated	Refer to "Sudden drop in gas flow or reduced flame height" (see above)
Flare-up	Grease buildup	Remove and clean all grill parts per "Cleaning and Care" section
	Excess fat in meat	Trim fat from meat before grilling
	Excessive cooking temperature	Adjust to lower cooking temperature
Persistent grease fire	Grease trapped by food buildup around burner system	<ol style="list-style-type: none"> Turn control knobs to ● (OFF) Turn gas cylinder valve to "OFF" Leave lid in closed position and let fire burn out After grill cools, remove and clean all parts per "Cleaning and Care" section
Flashback (fire in burner tube(s))	Burner and/or burner/venturi tube are blocked	Clean burners and/or burner/venturi tube
Inside of lid is peeling (like paint peeling)	Baked on grease buildup has turned to carbon and is flaking off.	Clean all grill parts per "Cleaning and Care" section.