

This Owner's Manual is provided and hosted by [Appliance Factory Parts](http://www.appliancefactoryparts.com).



# FISHER & PAYKEL DD24STX6HI1 Owner's Manual

[Shop genuine replacement parts for FISHER & PAYKEL  
DD24STX6HI1](#)



[Find Your FISHER & PAYKEL Dishwasher Parts - Select From 34 Models](#)

----- Manual continues below -----

**FISHER & PAYKEL**

**DISHDRAWER™ DISHWASHER**

---

**DD24STX6HI1 FP US CA**

**PRODUCT CODE: 82166-A**

**PARTS MANUAL**

**US CA**

# INTRODUCTION

---

BRAND	VOLTAGE	MODEL	PRODUCT CODE
Fisher & Paykel	110-120VAC 60Hz	DD24STX6HI1 FP US CA	82166-A

---

## MODELS

The model covered by this manual is listed on the front cover. The information detailed in this manual is subject to change without notice. The latest version is indicated by the reprint date and replaces any earlier editions.

## KIT PARTS

Where a part number is shown against the descriptions for kit components, they are also available as separate items. In addition, some parts may be supplied with these kits that are not available as separate items, and are therefore either not listed, or a part number is not shown against the part description in this manual.

## PARTS LIST KEY

NI	As a part reference, indicates the part is not illustrated on the diagram.
NOT USED	As a part number, indicates the diagram part reference is not used in this manual.
NS	As a part number, indicates the part is not servicable.

---

## US

Fisher & Paykel Appliances Inc.  
695 Town Center Drive, Suite 180  
Costa Mesa.  
CA 92626-1902  
USA

Customer Care: 1-888-936-7872  
Fax: (714) 372-7003  
Email: [usa.customercare@fisherpaykel.com](mailto:usa.customercare@fisherpaykel.com)

# CONTENTS

---

Introduction	1
Front panels/controls	3
Cabinet components	5
Lid & link components	7
Tub components	9
Basket & rack components	15
Installation components	19

# FRONT PANELS/CONTROLS

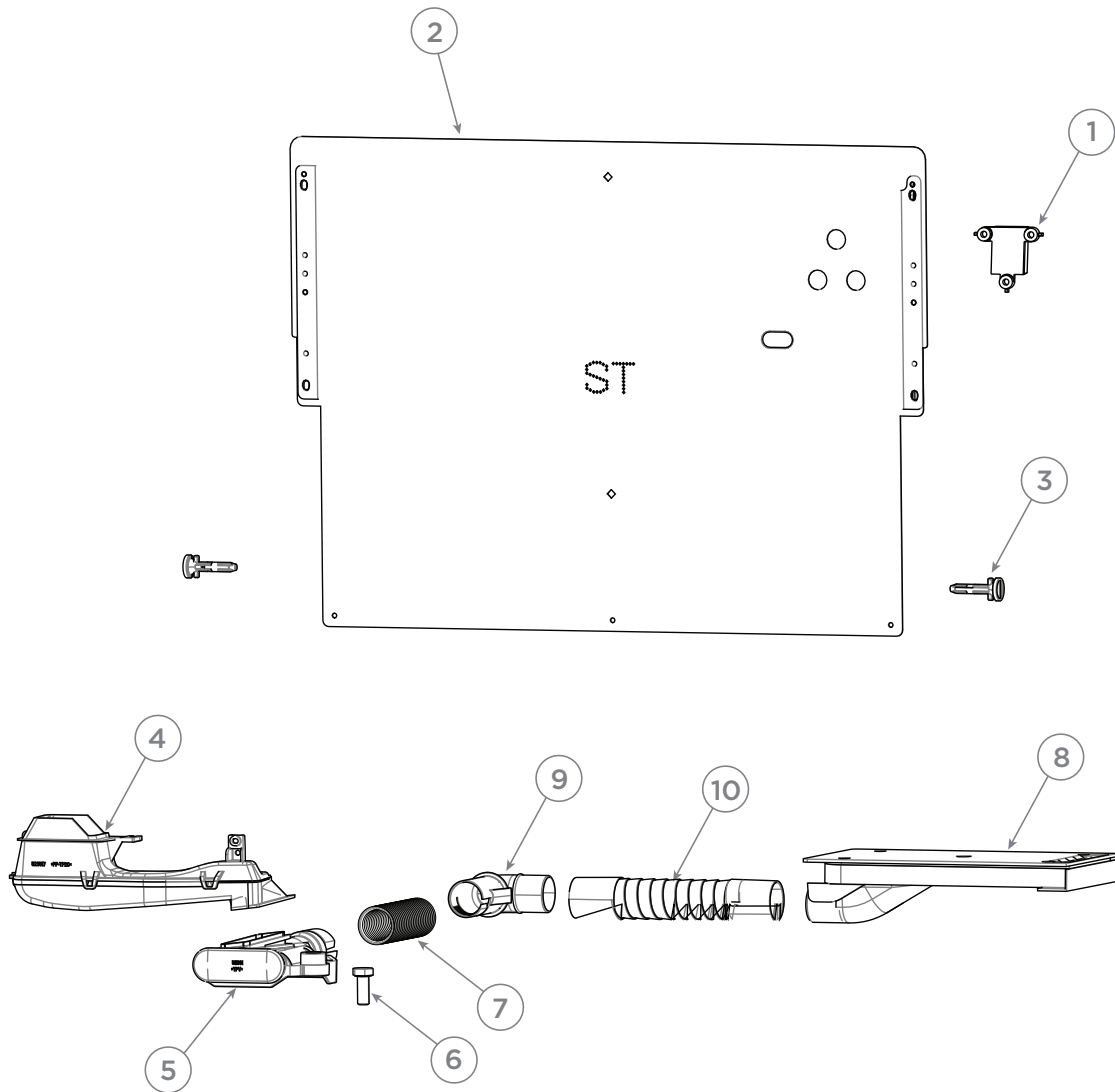

## FRONT PANELS/CONTROLS

REFERENCE	PART NUMBER	PART DESCRIPTION
<b>1</b>	<b>512054P</b>	<b>MOD KNOCK SENSOR 525 P9 SP</b>
<b>NI</b>	<b>528782P</b>	<b>SCREW WS 8X5/8 TWINFST (PKT10)</b>
<b>2</b>	<b>512843</b>	<b>KIT SHIELD INT UPR DS609T</b>
<b>3</b>	<b>515471</b>	<b>PIN DOOR DD6010</b>
<b>4</b>	<b>511886</b>	<b>DUCT TUB ASSY 609</b>
	Includes	DUCT TOP
	Includes	DUCT BTM
<b>NI</b>	<b>556155P</b>	<b>SCREW M3.5X14 PANTX K35 (PKT10)</b>
<b>NI</b>	<b>534140</b>	<b>WASHER M4 FLAT SS</b>
<b>5</b>	<b>511889</b>	<b>MANIFOLD CHASSIS ASSY 609</b>
	Includes	MANIFOLD SEAL
	Includes	MANIFOLD CAP
	Includes	BODY MANIFOLD
<b>6</b>	<b>523972</b>	<b>BOLT HEX M8X20 ZN</b>
<b>NI</b>	<b>524084</b>	<b>WASHER FLAT M8 ZNPL</b>
<b>7</b>	<b>523523</b>	<b>HOSE VENT CHASSIS</b>
<b>8</b>	<b>523526</b>	<b>DUCT EXIT ASSY</b>
	Includes	DUCT EXIT BOTTOM
	Includes	DUCT EXIT TOP
	Includes	SCREW M3-5X16 X 4
<b>9</b>	<b>523515</b>	<b>ELBOW VENT</b>
<b>10</b>	<b>523689</b>	<b>HOSE ASSY INSULATED</b>

# CABINET COMPONENTS

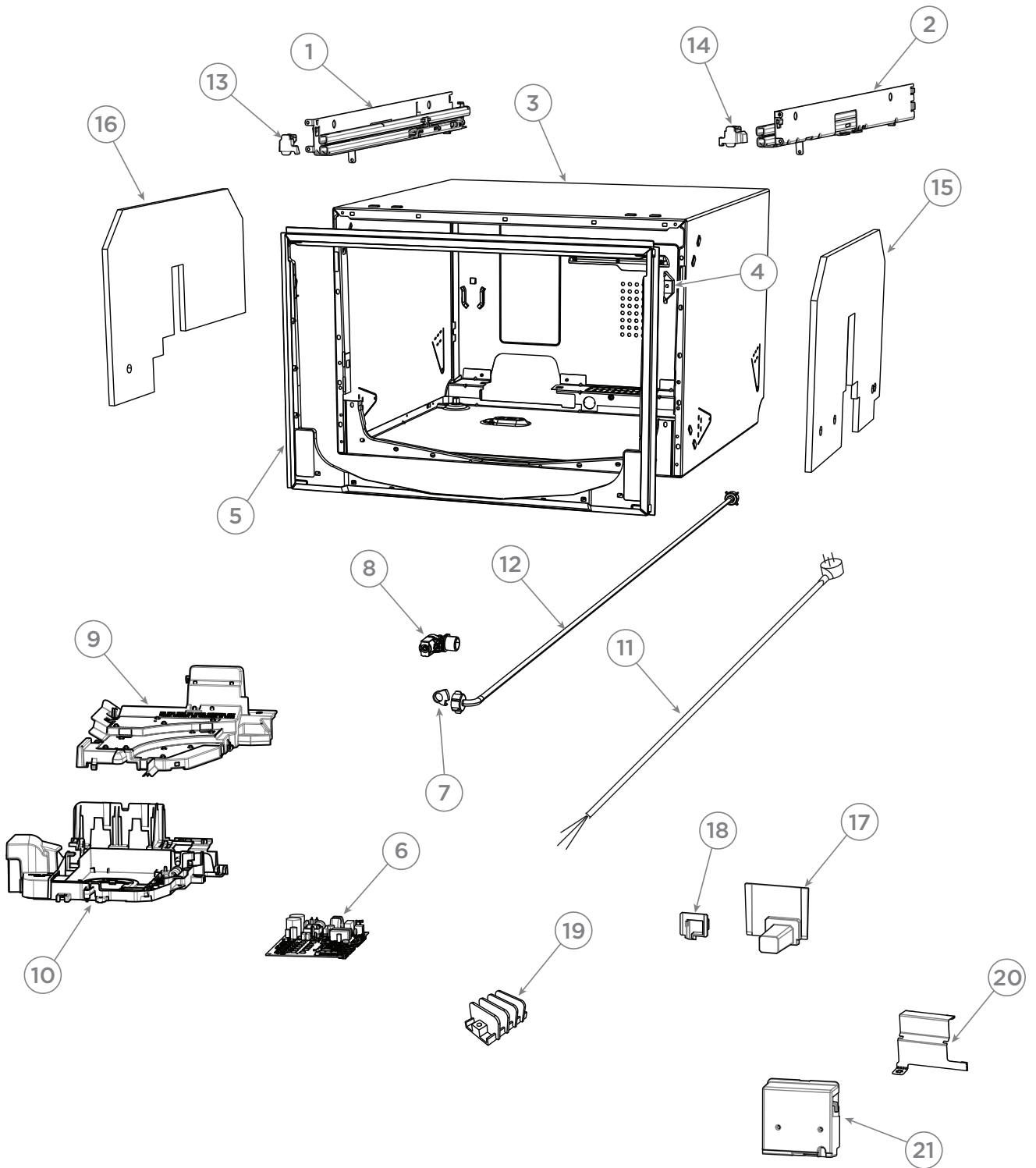

## CABINET COMPONENTS

REFERENCE	PART NUMBER	PART DESCRIPTION
<b>1</b>	<b>515110</b>	SLIDE ASSY LH DD6010
<b>2</b>	<b>515111</b>	SLIDE ASSY RH DD6010
<b>NI</b>	<b>556607P</b>	SCREW MC M5X10 TAPTITE (PKT 10)
<b>3</b>	<b>518623</b>	KIT REPLACE CHASSIS DS6010 SP
	Includes 525968	MOUNT LINK TOP
	Includes	CHASSIS ASSY DD6010
	Includes	SHT INSTR REPLACE CHASSIS PH10
	Includes	INSTALL TAB TTA
	Includes	INSTALL TAB TTB
	Includes	TRIM UPPER COMOULD TT ASSY
	Includes 524568	3 DEGREE PRISM (2)
<b>4</b>	<b>524568</b>	<b>3 DEGREE PRISM</b>
<b>5</b>	<b>522994</b>	KIT TRIMSEAL DD60ST
	Includes 524568	3 DEGREE PRISM
	Includes	CORNER PLUG TRIM DD60T6 TALL
<b>6</b>	<b>518590</b>	KIT MC 525 PH10 120V SGL SP
<b>7</b>	<b>525466</b>	CLAMP HOSE HERBIE TYPE E
<b>8</b>	<b>529827</b>	VALVE INLET SINGLE 605
<b>9</b>	<b>518384</b>	KIT HOUSING C. MODULE DD6010
	Includes	SEAL HEATSINK DD6010
<b>10</b>	<b>515685</b>	COVER MC ASSY DD6010 US
<b>11</b>	<b>516113</b>	FLEX MAINS DD2410 US
<b>NI</b>	<b>556607P</b>	SCREW MC M5X10 TAPTITE (PKT 10)
<b>12</b>	<b>525970</b>	HOSE INLET WIRSBO US
<b>13</b>	<b>515491</b>	CLIP TUB RELEASE RH DD6010
<b>14</b>	<b>515492</b>	CLIP TUB RELEASE LH DD6010
<b>15</b>	<b>522443</b>	INSULATION CHASSIS TOP TALL
<b>16</b>	<b>522444</b>	INSULATION CHASSIS SGL TALL
<b>17</b>	<b>518031</b>	COMMS CONNECTOR HOUSING PH10
<b>18</b>	<b>518032</b>	COMMS CONNECTOR COVER PH10
<b>NI</b>	<b>516199</b>	HARNESS COMMS CONNECTOR PH10
<b>19</b>	<b>524600</b>	TERMINAL BLOCK OK501/3
<b>20</b>	<b>515586</b>	SHIELD 4 MC DD2410
<b>NI</b>	<b>516114</b>	AUX FLEX DD2410 US
<b>21</b>	<b>515603</b>	HOUSING HARD WIRING DD6010



# LID & LINK COMPONENTS

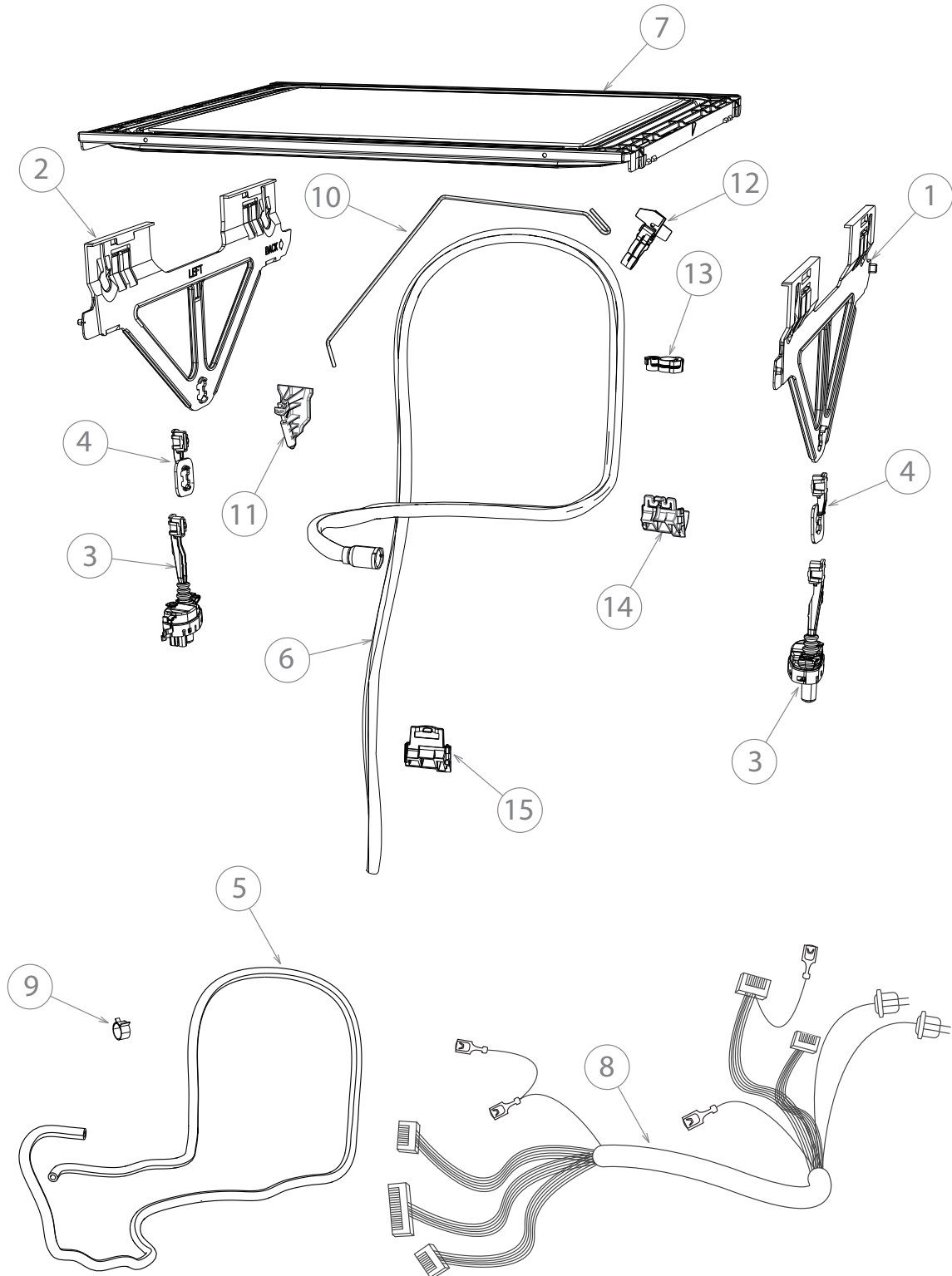

## LID & LINK COMPONENTS

REFERENCE	PART NUMBER	PART DESCRIPTION
<b>1</b>	<b>529969</b>	LID YOKE RIGHT
<b>2</b>	<b>529970</b>	LID YOKE LEFT
<b>3</b>	<b>522085</b>	KIT LID ACTUATORS 605 (PKT 2)
<b>4</b>	<b>522296P</b>	KIT ADAPTOR LID YOKE TALL TUB (PKT 2)
<b>5</b>	<b>518414</b>	KIT DD FILL HOSE UPPER PH10
<b>6</b>	<b>518415</b>	KIT DD DRAIN HOSE UP SPARE P10
	Includes	O RING CUFF SOCKET UL REC
	Includes	HOSE DRAIN UPR ASSY SPARE PH10
	Includes	FLAP VALVE DRAIN 605
<b>NI</b>	<b>525798</b>	KIT DRAIN HOSE EXTENSION 3.6M
	Includes	DRAIN HOSE EXTENSION (2)
	Includes 525482	CLIP WIRE DRAIN (4)
	Includes	DRAIN HOSE JOINER (2)
<b>NI</b>	<b>527394</b>	KIT DRAIN HOSE JOINER
	Includes 525482	CLIP WIRE DRAIN (2)
	Includes	DRAIN HOSE JOINER
<b>7</b>	<b>529964P</b>	LID ASSY 605
<b>8</b>	<b>518417</b>	KIT DD HARNESS UPPER PH10
<b>9</b>	<b>528674</b>	CLAMP HOSE TYPE 12232-17-4
<b>10</b>	<b>514642</b>	ROD LINK SUPPORT 6010
<b>11</b>	<b>514643</b>	BRACKET LINK SUPPORT DD6010
<b>12</b>	<b>524541</b>	CLIP LINK SUPPORT 608
<b>13</b>	<b>524543</b>	CLIP LINK CHASSIS SIDE
<b>14</b>	<b>514914</b>	CLIP LINK TUB RIB DD6010
<b>15</b>	<b>524478</b>	MOUNT LINK CHASSIS 608
<b>NI</b>	<b>515367</b>	HARNESS UPPER LID VALVE DD6010

# TUB COMPONENTS

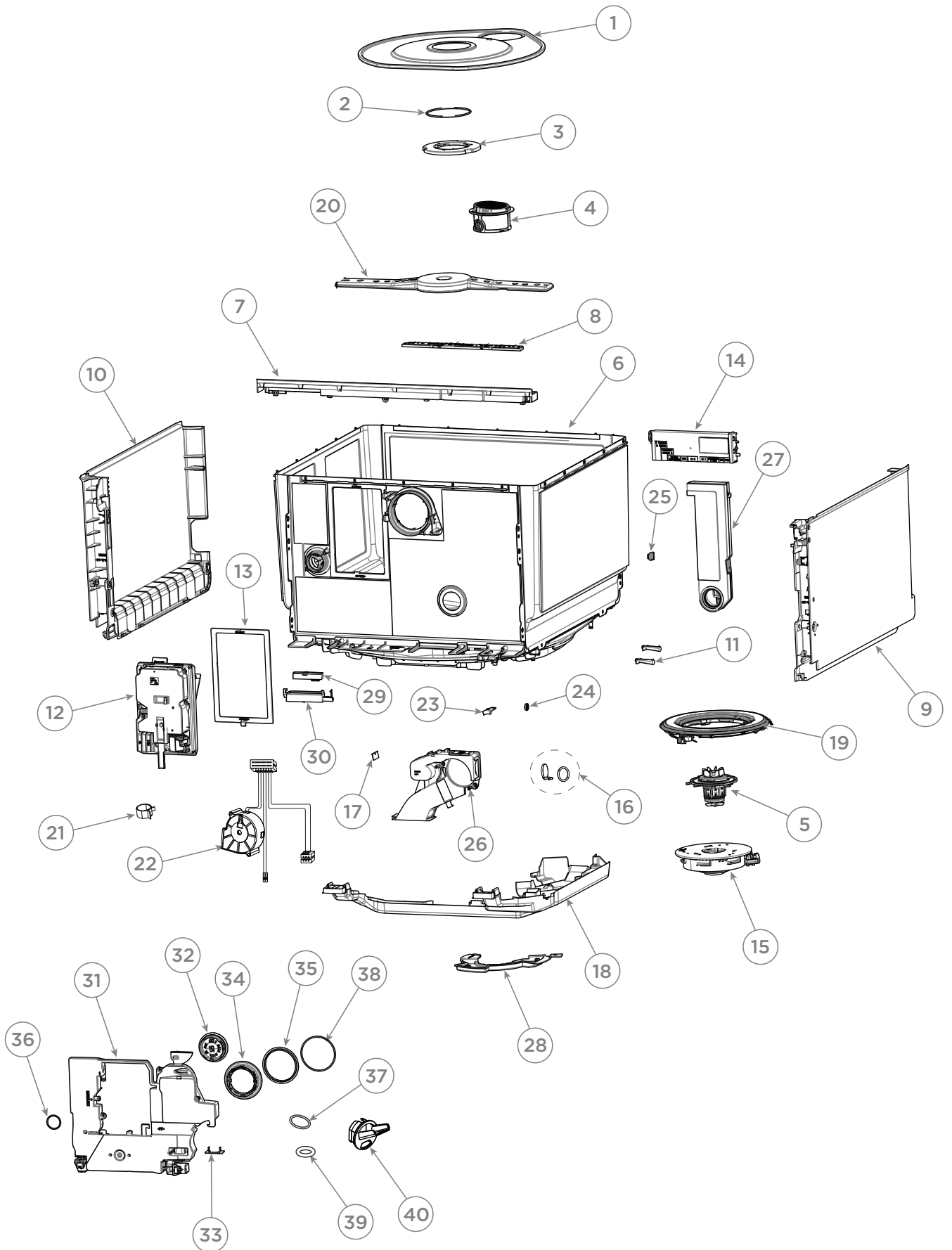

## TUB COMPONENTS

REFERENCE	PART NUMBER	PART DESCRIPTION
<b>1</b>	<b>515915</b>	FP SS ROLL UNLD DD6010
<b>2</b>	<b>515609</b>	FILTER PLATE O-RING DD6010
<b>3</b>	<b>515589</b>	FILTER PLATE LOCKNUT DD6010
<b>4</b>	<b>515564</b>	FILTER DD6010
	Includes	FILTER MICRO OVERMOULD DD6010
	Includes	FILTER DRAIN WELDED DD6010
<b>5</b>	<b>514875P</b>	KIT ROTOR ASSY DD6010 SP
<b>6</b>	<b>518428</b>	KIT TUB SS TALL SGL DD6010
<b>NI</b>	<b>611811P</b>	SCREW ST 8X1/2 PAN SS (PKT10)
<b>7</b>	<b>518567</b>	KIT USER INTERFACE DD6010
<b>8</b>	<b>514985P</b>	PCBA UI FLANGE DD PH10
<b>9</b>	<b>515179</b>	TUB SIDE SUPPORT RH DD60T10
<b>10</b>	<b>515180</b>	TUB SIDE SUPPORT LH DD60T10
<b>11</b>	<b>524569</b>	3 DEGREE LIGHTPIPE PH8
<b>12</b>	<b>518565</b>	KIT DISPENSER PH10 (SP)
	Includes	DISPENSER DD6010
<b>NI</b>	<b>556155P</b>	SCREW M3.5X14 PANTX K35 (PKT 10)
<b>13</b>	<b>518593</b>	KIT WASH CTRL PH10 US TW
<b>NI</b>	<b>556155P</b>	SCREW M3.5X14 PANTX K35 (PKT 10)
<b>14</b>	<b>514876P</b>	KIT STATOR ASSY DD6010 SP
	Includes	ELEMENT INNER SEAL DD6010
<b>NI</b>	<b>556155P</b>	SCREW M3.5X14 PANTX K35 (PKT 10)
<b>15</b>	<b>522150</b>	KIT FLAP VALVE/O RING 605 (PKT 2)
	Includes	FLAP VALVE DRAIN 605 (2)
	Includes	O RING CUFF SOCKET UL REC (2)
<b>16</b>	<b>515252</b>	FLAP VALVE FAN HOUSING DD6010
<b>17</b>	<b>515473</b>	COVER TUB BASE DD6010
<b>NI</b>	<b>556155P</b>	SCREW M3.5X14 PANTX K35 (PKT 10)
<b>18</b>	<b>516079P</b>	KIT ELEMENT & SEAL 6010 120V
	Includes	ELEMENT OUTER SEAL DD6010
	Includes	ELEMENT INNER SEAL DD6010
	Includes	ELEMENT DD2410 120V

# TUB COMPONENTS

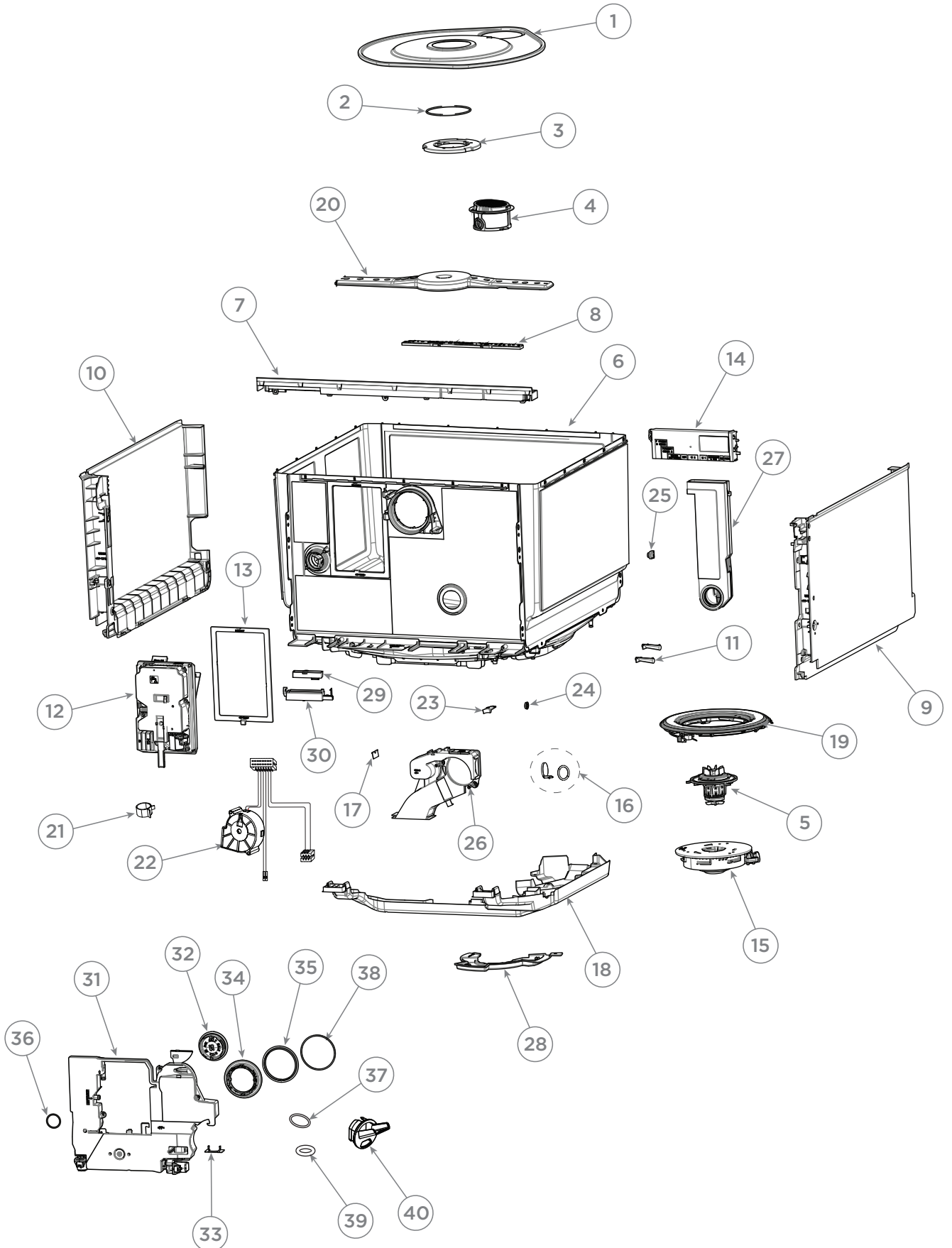

DWG 005775

## TUB COMPONENTS

REFERENCE	PART NUMBER	PART DESCRIPTION
<b>20</b>	<b>515617</b>	<b>SPRAYARM VALUE ASSY DD6010</b>
<b>21</b>	<b>528674</b>	<b>CLAMP HOSE TYPE 12232-17-4</b>
<b>22</b>	<b>513149</b>	<b>HARNESS DISPEN FAN 270MA P9</b>
<b>23</b>	<b>528064</b>	<b>RETAINER FLAP FAN HOUSING 605</b>
<b>NI</b>	<b>611811P</b>	<b>SCREW ST 8X1/2 PAN SS (PKT10)</b>
<b>24</b>	<b>515734</b>	<b>WASHER CUP M5</b>
<b>25</b>	<b>515255</b>	<b>BUSH SIDE SUPPORT</b>
<b>26</b>	<b>518599P</b>	<b>SS FAN KIT ASSY SI DD6010</b>
	Includes	SS FAN HOUSING ASSY DD6010
	Includes	RUBBER NUT FAN DD6010
	Includes	SCREW M3X40 CSK
	Includes	FLAP VALVE FAN HOUSING DD6010
	Includes	GATE DRYFAN PH10.PRT
	Includes	VENTING CAP SEAL DD6010
	Includes	CAP VENTING
	Includes	RETAINER FLAP FAN HOUSING 605
<b>27</b>	<b>514604</b>	<b>SS REAR VENT ASSY DD6010</b>
	Includes	VENT REAR BOTTOM DD6010
	Includes	VENT REAR TOP DD6010
<b>28</b>	<b>515573</b>	<b>ELEMENT MOTOR WIRE COVER DD601</b>
<b>NI</b>	<b>515370</b>	<b>HARNESS TURBIDITY DD6010</b>
<b>NI</b>	<b>515972</b>	<b>HARNESS HALL SENSOR DD6010</b>
<b>29</b>	<b>563774P</b>	<b>MOD WIFI GEA3 LITE SVC</b>
<b>30</b>	<b>518016</b>	<b>DD BRACKET WIFI</b>
<b>NI</b>	<b>515527</b>	<b>HARNESS WIFI DD6010</b>
<b>31</b>	<b>516266</b>	<b>KIT WATER SOFTENER DD6010 SP</b>
	Includes	WATER SOFTENER DD6010
	Includes 526718	O RING OVERFLOW SOFTENER
	Includes 526717	O RING SALT TANK
	Includes 556155P	SCREW ST M3.5X14 K35 PAN TX ZP
	Includes 515585	HOSE EXTENSION WATER SOFTENER
	Includes 522351	O RING STRAINER SOFTENER
	Includes 515680	BUNG SALT SOFTENER DD6010

# TUB COMPONENTS

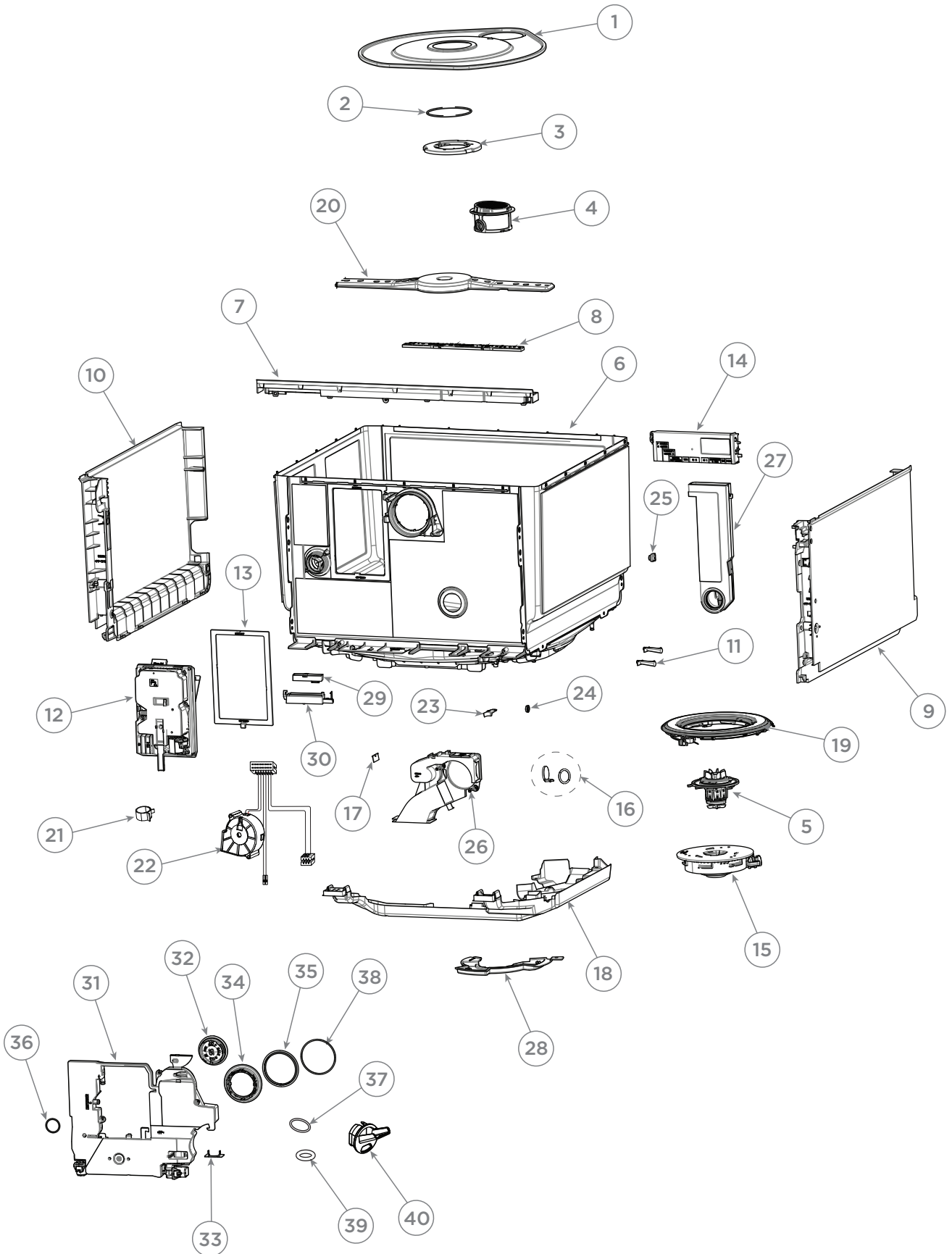

DWG 005775

## TUB COMPONENTS

REFERENCE	PART NUMBER	PART DESCRIPTION
	Includes 516103	PCB SALT LEVEL 6010
<b>32</b>	<b>515680</b>	<b>BUNG SALT SOFTENER DD6010</b>
<b>33</b>	<b>516103</b>	<b>PCB SALT LEVEL 6010</b>
<b>NI</b>	<b>515746</b>	<b>HARNESS WATER SOFTENER DD6010</b>
<b>NI</b>	<b>516139</b>	<b>HOSE FILL CO-EX SOFTENER 6010</b>
<b>34</b>	<b>514957</b>	<b>WS BUNG RING DD6010</b>
<b>35</b>	<b>514959</b>	<b>WS BUNG RING SEAL DD6010</b>
<b>36</b>	<b>514960</b>	<b>WS OVERFLOW RING SEAL DD6010</b>
<b>37</b>	<b>526718</b>	<b>O RING OVERFLOW SOFTENER</b>
<b>38</b>	<b>526717</b>	<b>O RING SALT TANK</b>
<b>NI</b>	<b>515585</b>	<b>HOSE EXTENSION WATER SOFTENER</b>
<b>39</b>	<b>522351</b>	<b>O RING STRAINER SOFTENER</b>
<b>40</b>	<b>515719</b>	<b>FUNNEL SALT FILLING</b>



# BASKET & RACK COMPONENTS

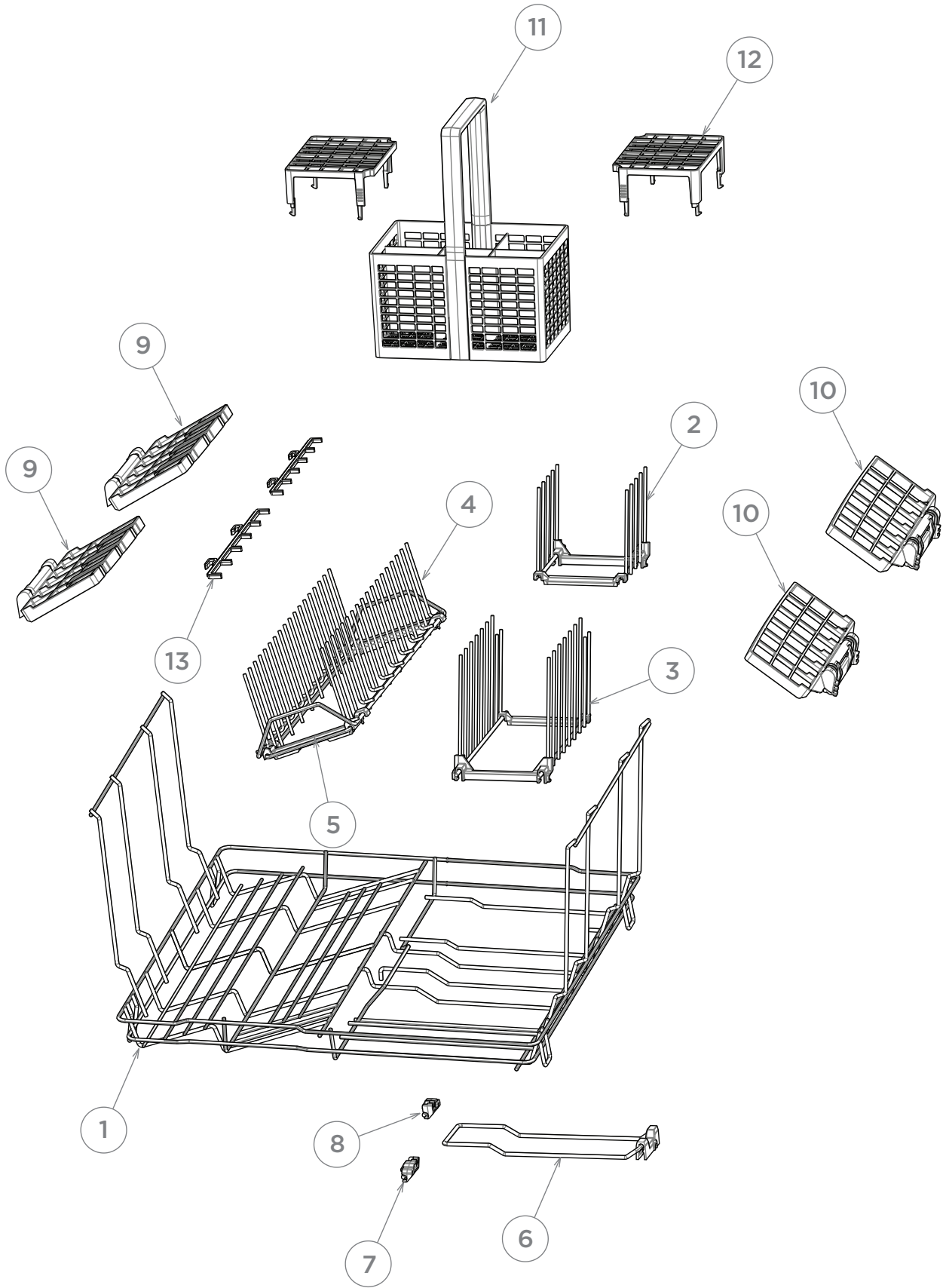

## BASKET & RACK COMPONENTS

REFERENCE	PART NUMBER	PART DESCRIPTION
<b>1</b>	<b>515815</b>	<b>BASERACK ASSY DD6010S7T CTD (TALL)</b>
<b>2</b>	<b>515183</b>	<b>MAIN COMB RR ASSY DD6010</b>
	Includes	COMBS MAIN RR LH 7PS CTD
	Includes	COMBS MAIN RR RH 7PS CTD
	Includes	CLIP FOLDDOWN DD609
	Includes	CLIP FNT FOLDDOWN 94
<b>3</b>	<b>515189</b>	<b>MAIN COMB RF ASSY DD6010</b>
	Includes	COMBS MAIN RR LH 7PS CTD
	Includes	COMBS MAIN RR RH 7PS CTD
	Includes	CLIP FOLDDOWN DD609
	Includes	CLIP FNT FOLDDOWN 94
<b>4</b>	<b>518147</b>	<b>CROCK INS PA 60 ASSY DD6010</b>
	Includes	COMB PA FIXED DD6010 CTD
	Includes	COMB PA MOVING 60 CTD
	Includes	CLIP PA FRONT 60
	Includes	CLIP PA BACK 60
<b>5</b>	<b>524147</b>	<b>KIT CLIP FRONT/BACK PA</b>
	Includes	CLIP PA FRONT 60
	Includes	CLIP PA BACK 60
<b>6</b>	<b>515169</b>	<b>TRAPDOOR ASSY KIT DD6010</b>
	Includes	TRAPDOOR REAR CLIP DD6010
	Includes	TRAPDOOR WIRE LOOP CTD
	Includes	CLIP TRAP DOOR FIX FRONT 6010
	Includes	CLIP TRAP DOOR FIX BACK 6010
<b>7</b>	<b>515173</b>	<b>RACK CUP LH DD60 ASSY PH10</b>
<b>8</b>	<b>524180</b>	<b>RACK CUP RH DD60 80MM ASSY</b>
	Includes	CLIP CUPRACK SEMIFLEXI
	Includes	CUPRACK SEMIFLEXI 80MM
<b>NI</b>	<b>522694P</b>	<b>KIT CLIP SEMIFLEX (PKT 4)</b>
<b>9</b>	<b>518649</b>	<b>KIT CLIP FOLDDOWN PH10</b>
	Includes	CLIP FOLDDOWN DD609
	Includes	CLIP FNT FOLDDOWN 94

# BASKET & RACK COMPONENTS

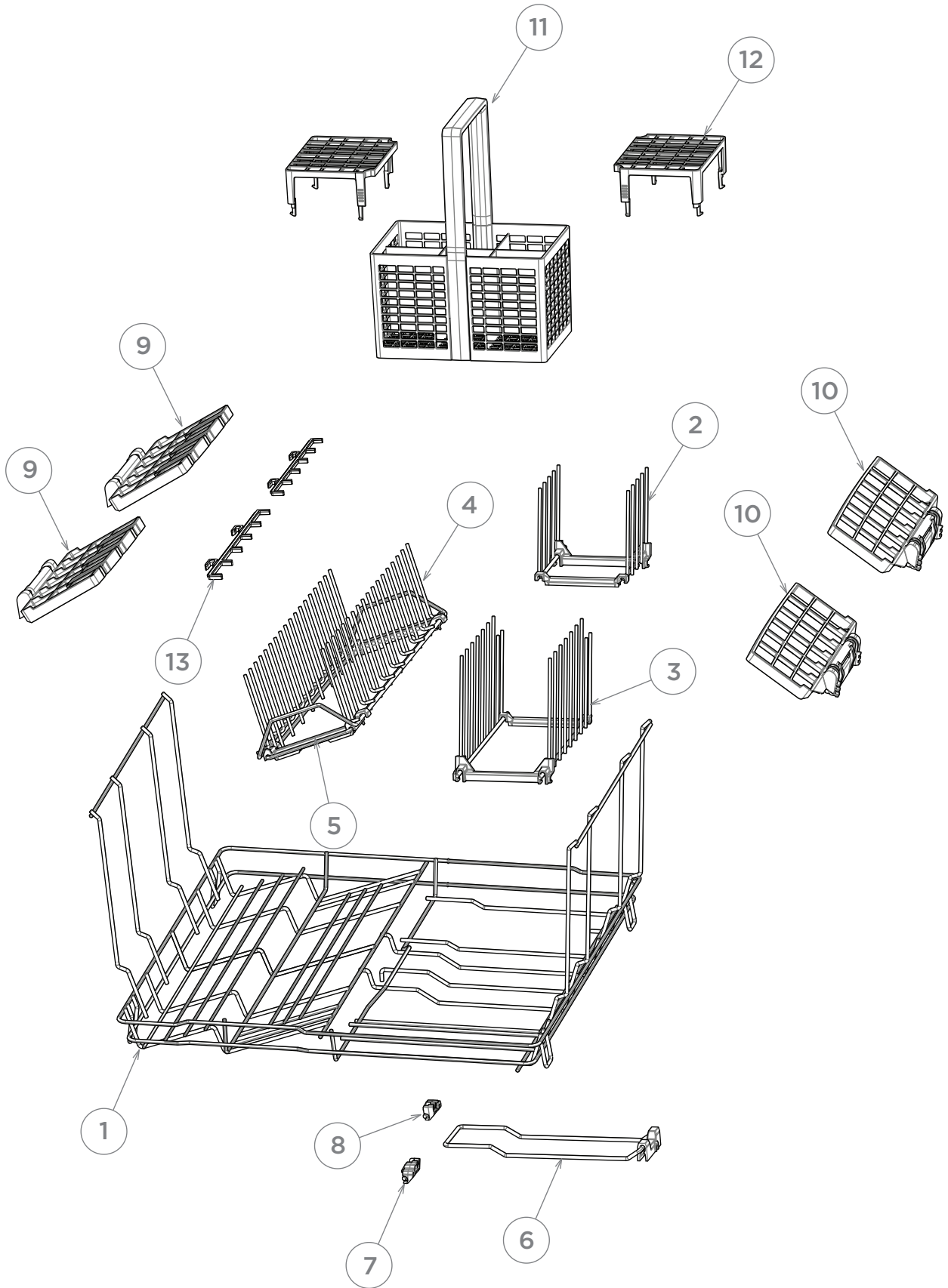

## BASKET & RACK COMPONENTS

---

REFERENCE	PART NUMBER	PART DESCRIPTION
<b>10</b>	<b>511870</b>	BASKET CUTLERY 60 ASSY MID-GY
<b>11</b>	<b>511874</b>	INSERT ST C BASKET 60 MID-GREY
<b>12</b>	<b>511872</b>	INSERT TABLET 60 MID-GREY
<b>13</b>	<b>522691P</b>	KIT SUPPORT GLASS CLIPON (PKT 2)

# INSTALLATION COMPONENTS

---

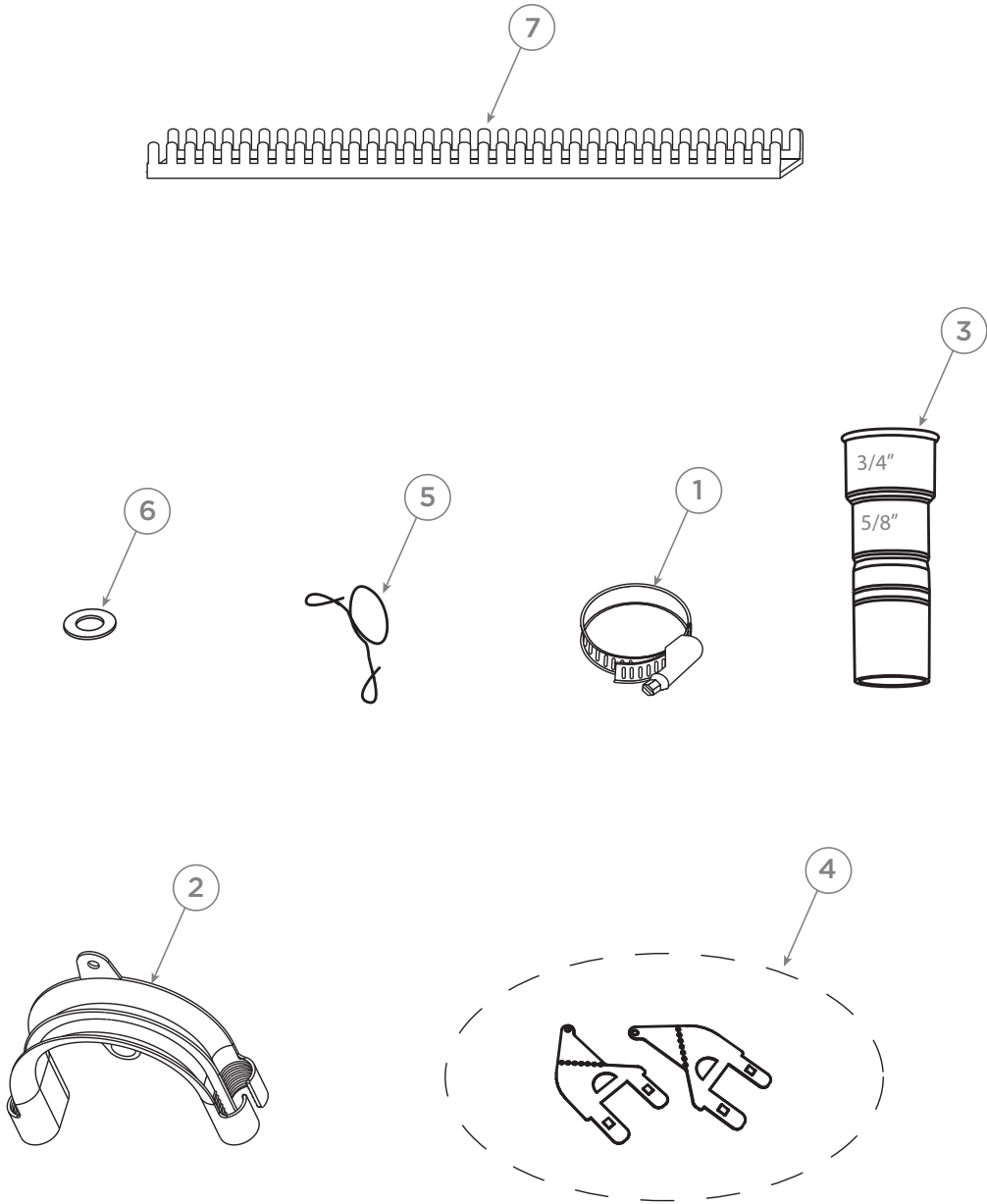

## INSTALLATION COMPONENTS

REFERENCE	PART NUMBER	PART DESCRIPTION
<b>1</b>	<b>528690</b>	<b>CLAMP HOSE DIA 32-14</b>
<b>2</b>	<b>525477</b>	<b>SUPPORT DRAIN HOSE</b>
<b>3</b>	<b>529075</b>	<b>JOINER DRAIN HOSE SGL US</b>
<b>4</b>	<b>523007</b>	<b>KIT INSTALL TAB DISHDRAWER</b>
	Includes	TAB TOP (2)
	Includes	INSTALL TAB TTA (2)
	Includes	INSTALL TAB TTB (2)
	Includes	SCREW WS 8X5/8TWINFST MTSPH ZP (6)
<b>5</b>	<b>525482P</b>	<b>CLIP WIRE DRAIN (PKT 2)</b>
<b>6</b>	<b>516202P</b>	<b>WASHER INLET HOSE (PKT 10)</b>
<b>7</b>	<b>525935</b>	<b>EDGE 160MM 22PKG020 UHMPWE US</b>
<b>NI</b>	<b>522995</b>	<b>KIT INSTALL DBL/SGL PH5/PH6</b>
	Includes 525477	SUPPORT DRAIN HOSE
	Includes 525482	CLIP WIRE DRAIN (2)
	Includes 525067	DRAIN SPIGOT CONNECTOR DOUBLE
	Includes 525460	DRAIN SPIGOT CONNECTOR SINGLE
	Includes 528690	CLAMP HOSE DIA 32-14
	Includes	SCREW WS 8X5/8 TWIN FAST (7)
	Includes 526797	TAB TOP (2)
	Includes	FOOT TOOL 605
	Includes	FOOT TOOL 45MM 605
	Includes	INSTALL TAB TTA (2)
	Includes	INSTALL TAB TTB (2)
	Includes	CORNER PLUG TRIM DDTALL (4)
	Includes 527208	TAPE UNDERBENCH CONDENSATION
<b>NI</b>	<b>527208</b>	<b>TAPE UNDERBENCH CONDENSATION</b>
<b>NI</b>	<b>524085</b>	<b>KIT BRACKET CAVITY PH7</b>
<b>NI</b>	<b>592429</b>	<b>BK UG DD24STX1 US CA</b>
<b>NI</b>	<b>592402</b>	<b>BK IG DD24 TXI US CA</b>
<b>NI</b>	<b>590256</b>	<b>BOOK SERVICE &amp; WARR'TY FP/EL</b>

## **FISHERPAYKEL.COM**

© Fisher & Paykel Appliances Ltd 2021. All rights reserved.

The product specifications in this document apply to the specific products and models described at the date of issue. Under our policy of continuous product improvement, these specifications may change at any time. You should therefore check with your Dealer to ensure this document correctly describes the product currently available.

For current details about model and specification availability in your country, go to our website [fisherpaykel.com](http://fisherpaykel.com) or contact your local Fisher & Paykel dealer

**PRODUCT CODE: 82166-A 08.21**