

**Breadman<sup>®</sup>**

**INSTRUCTION  
MANUAL**



**AUTOMATIC BREAD BAKER**



## TABLE OF CONTENTS

Important Safeguards .....	1
Your Breadman® Bread Baker .....	2
Control Panel .....	3
Using the Breadman® .....	4 - 5
Kneading and Baking Cycles .....	6
Making Dough and Baking Bread .....	7 - 11
Using the Timer .....	12 - 13
Cleaning Instructions .....	14
Trouble Shooting .....	15 - 17
Specifications .....	18
Notes .....	19 - 20
Warranty .....	21



# IMPORTANT SAFEGUARDS

When using the Breadman® Automatic Bread Baker, basic safety precautions should always be followed, particularly the following:

1. **READ ALL INSTRUCTIONS BEFORE USE.**
2. Do not touch hot surfaces. Use handles or knobs. Always use oven mitts when handling hot materials and allow metal parts to cool before cleaning.
3. Unplug this product from wall outlet when not in use and before cleaning. Allow to cool thoroughly before putting on or taking off parts.
4. Do not immerse appliance in water or any other liquid.
5. Close supervision is always necessary when this or any appliance is used by or near children.
6. Do not allow anything to rest on the power cord. Do not plug in cord where persons may walk or trip on it.
7. Do not operate this or any appliance with a frayed or damaged cord, or after the appliance malfunctions, or has been damaged in any manner. Return the appliance to Salton/MAXIM Housewares, Inc. Repair Dept. for examination and repair.
8. Avoid contact with any moving parts.
9. Do not use attachments not recommended by Salton/MAXIM Housewares, Inc.; they may damage the appliance or cause injury.
10. This appliance is intended for household use only. Do not use outdoors or for commercial purposes
11. Do not let the cord hang over the edge of a table or counter, or touch hot surfaces. Do not place on an unsteady or cloth-covered surface.
12. Do not place the appliance near a hot gas or electric burner, in a heated oven or in a microwave.
13. Keep the unit at least 2 inches away from walls or any other objects when using it.
14. To disconnect, grip the plug and pull the plug from the wall outlet. Never pull on the cord.

## SAVE THESE INSTRUCTIONS

**Note:**

- A. A short power-supply cord is provided to reduce the risk of becoming entangled in or tripping over a longer cord.
- B. If an extension cord is used:
  - (1) the marked electrical rating of the extension cord should be at least as great as the electrical rating of the appliance, and
  - (2) the cord should be arranged so that it will not drape over the counter top or tabletop where it can be pulled on by children or tripped over unintentionally.

**CAUTION:** During use, the internal parts of the Breadman® and the area around the Steam Vent are **HOT**. **Keep out of reach of children to avoid possible injury.**

**FOR HOUSEHOLD USE ONLY**



## YOUR BREADMAN®

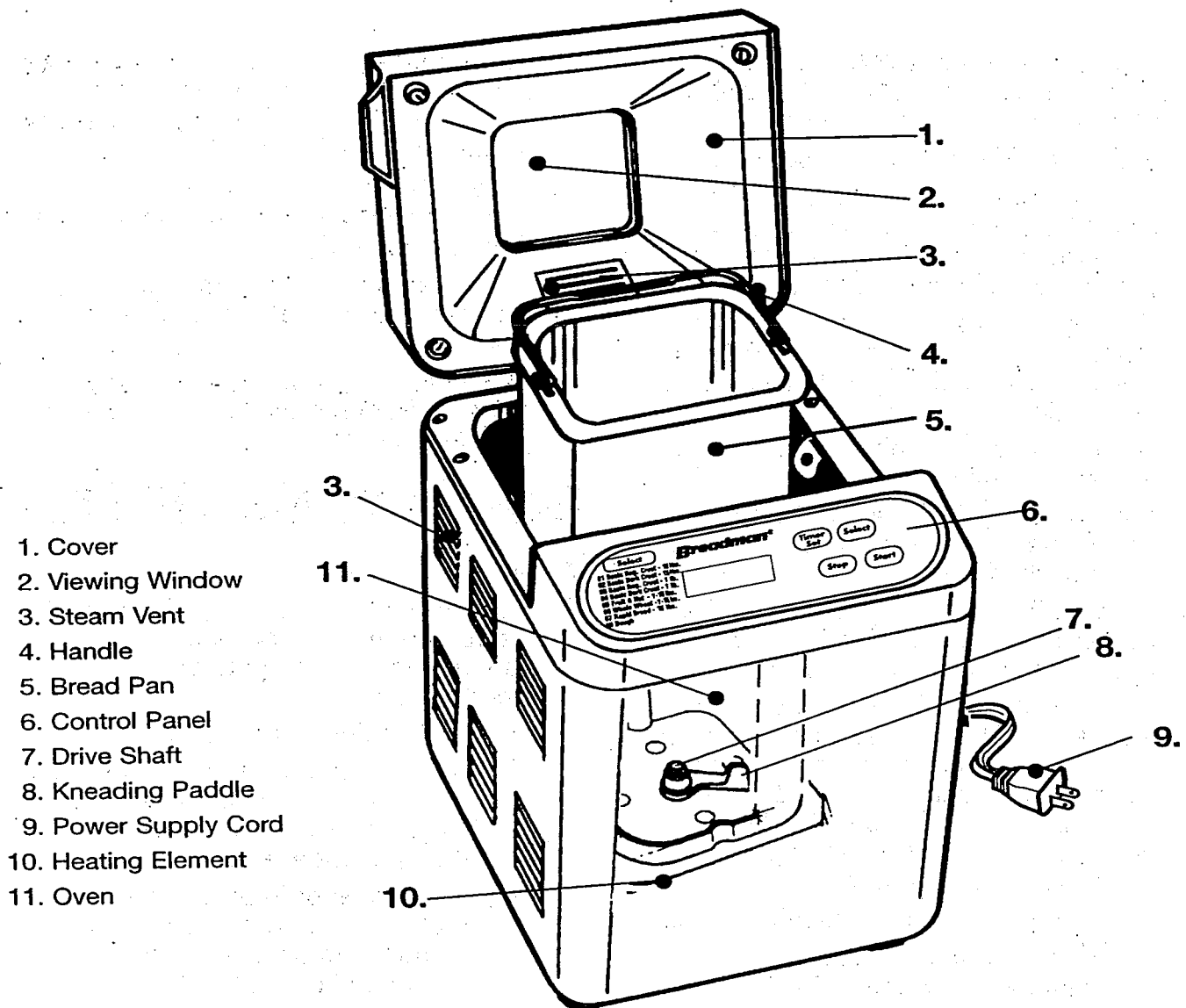

1. Cover
2. Viewing Window
3. Steam Vent
4. Handle
5. Bread Pan
6. Control Panel
7. Drive Shaft
8. Kneading Paddle
9. Power Supply Cord
10. Heating Element
11. Oven

### POLARIZED PLUG

This appliance has a **polarized plug** (one blade is wider than the other). To reduce the risk of electric shock, this plug is intended to fit into a polarized outlet only one way. If the plug does not fit fully in the outlet, reverse the plug. If it still does not fit, contact a qualified electrician. Do not attempt to modify the plug in any way.



## CONTROL PANEL

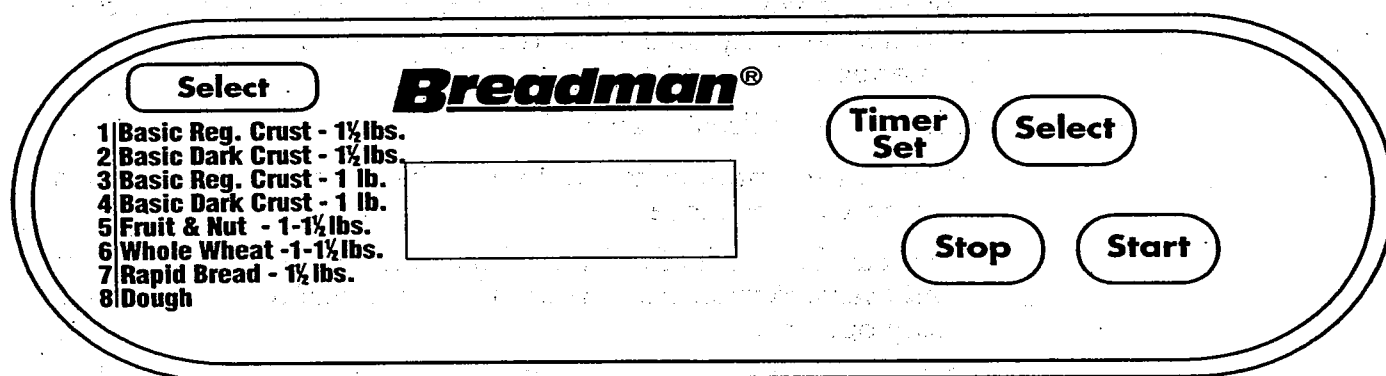

### A. Display Window

Shows your selection and Timer setting.

### B. Selection Options

Select from these bread choices:

Basic (Regular Crust, 1-1/2 lbs.)

Basic (Dark Crust, 1-1/2 lbs.)

Basic (Regular Crust, 1 lb.)

Basic (Dark Crust, 1 lb.)

Fruit & Nut (1 - 1-1/2 lbs.)

Whole Wheat (1 - 1-1/2 lbs.)

Rapid Bake

Dough

### C. Timer Set

Use this button to add time displayed in the Display Window.

Each time you press this button, the Timer advances 10 minutes. (*Hint: Hold down the button for speedier results.*)

*\*See page 12 for detailed instructions.*

### D. Select

Press this button to select the Baking cycle you want. Each time you press this button, the selection number appears on the Display Window.

Press this button until your choice number shows.

### E. Start

Press this button to start the Baking cycle you choose, or to start the Timer.

### F. Stop

Press this button for half a second to turn off power, to reset the Baking cycle or Timer setting, or to stop baking.

*When you press the Timer, Select, Start, or Stop button, you should hear a beep. This lets you know you've pressed hard enough and your selection was made.*



## USING THE BREADMAN®

Before using your Breadman® Automatic Bread Baker for the first time, carefully read all of the instructions included in this manual.

With your new Breadman®:

- You can use pre-packaged bread mixes. Recipe instructions are on each package.
- You can bake a loaf of bread from scratch. See the *Recipe and Menu Planner* included with your Breadman® for lots of tasty options.
- You can make dough for rolls or shaped loaves you'll bake in your oven. Use the Dough cycle to do the mixing and kneading for you, then shape and bake the bread yourself.
- To insert the Bread Pan in the Bread Baker, seat it in place with the marking "Lock" facing 6 or 12 o'clock. Then, in a clockwise movement, turn the pan to 1 or 7 o'clock and it will fit into place.

### Inserting and Removing the Bread Pan

Remember to insert the Kneading Paddle first, then add all your ingredients BEFORE inserting the Bread Pan into the Oven of your Breadman®.

- To remove the Bread Pan from the Oven, hold the Handle with an oven mitt and lift gently as you turn counter-clockwise until the word "Remove" is as 5 or 11 o'clock.
- When you remove the Bread Pan after baking, BE SURE TO WEAR OVEN MITTS to prevent burning. After you remove the loaf by turning the Bread Pan upside down and shaking gently, check to see that the Kneading Paddle is removed from the loaf. If it is stuck in your bread, use a non-metal utensil to gently remove it, taking care not to scratch the Kneading Paddle.

### Operating Tips

- Use oven mitts when working with bread or any part of the Breadman® that is hot from baking.
- Wipe off crumbs and clean the Breadman®, as needed, after baking.
- Unplug the Breadman® when you are not using it.



## USING THE BREADMAN® (continued)

### Caution

- It is normal for the Viewing Window to collect moisture during the beginning of the Baking cycle. As your bread bakes, the moisture will soon evaporate so you can watch your bread's baking progress.
- Don't open the Lid during Baking. This causes the bread to bake improperly.
- Don't unplug the Breadman® during Kneading or Baking. This will stop the operation.
- To protect young children, keep the Breadman® out of their reach when you're not there to supervise — especially during the Kneading and Baking cycles.
- Use the Breadman® Bread Baker on a flat, hard surface. Don't place it near a flame or heat, or on a soft surface (such as a carpet). Avoid placing it where it may tip over during use. Dropping the Breadman® could cause it to malfunction.
- To avoid burns, stay clear of the Steam Vent during Kneading and Baking. Also, don't touch the Viewing Window — it gets very hot.
- After baking, wait for the Breadman® to cool down before touching or cleaning the Bread Pan or internals of the Breadman® without oven mitts.
- Never use metal utensils with the Breadman® Bread Baker. These can scratch the non-stick surface of the Bread Pan.
- Avoid electric shock by unplugging the unit before using a damp cloth or sponge to wipe the interior of the Oven.
- Never use the Bread Pan on a gas or electric cooktop or on an open flame.
- Avoid covering the Steam Vent during Kneading and Baking cycles. This could cause the Breadman® to warp or discolor.



# KNEADING AND BAKING CYCLES

The Breadman® Automatic Bread Baker has various cycles from which to choose:

- The Basic Regular and Basic Dark Baking cycles let you choose your favorite crust for most bread varieties, including whole wheat, rye and white breads.
- Fruit & Nut cycle is for breads such as apple walnut, banana, and raisin bread.

This table shows how long each part of the Baking cycle takes:

## SELECTION

BAKING PHASE	Basic Reg. Crust 1-1/2 lb.	Basic Dark Crust 1-1/2 lb.	Basic Reg. Crust 1 lb.	Basic Dark Crust 1 lb.	Whole Wheat 1-1/2 lb.	Fruit & Nut 1-1/2 lb.	Rapid Bake	Dough
Pre-Heat	4 min.	4 min.	4 min.	4 min.	5 min.	4 min.	—	—
Knead I	15 min.	15 min.	10 min.	10 min.	20 min.	15 min.	15 min.	15 min.
Rest	28 min.	28 min.	24 min.	24 min.	30 min.	28 min.	12 min.	30 min.
Knead II	23 min.	23 min.	12 min.	12 min.	25 min.	23 min.*	23 min.	23 min.
Rise	20 min.	20 min.	20 min.	20 min.	30 min.	20 min.	10 min.	20 min.
Punch Down	3 sec.	3 sec.	3 sec.	3 sec.	3 sec.	3 sec.	3 sec.	3 sec.
Final Rise	60 min.	60 min.	60 min.	60 min.	60 min.	60 min.	60 min.	—
Bake	50 min.	50 min.	50 min.	50 min.	50 min.	50 min.	50 min.	—
END	—	—	—	—	—	—	—	—
Hold/Warm	3 hrs.	3 hrs.	3 hrs.	3 hrs.	3 hrs.	3 hrs.	3 hrs.	—
Total Baking Time	3:20	3:20	3:10	3:10	3:40	3:20	2:50	1:28

For Whole Wheat cycle except Rapid cycle, which is 15 minutes, the mix initially rises for up to 30 minutes. No movement occurs in the pan. This is normal.

\*Machine will beep 5 minutes before the end of the cycle. This is the time to add any dried fruits and/or nuts.

\*\*Note: If bread is not removed immediately after baking, and "STOP" button is not pressed, a controlled Keep Warm phase will begin for each selection. While this will help reduce condensation between loaf and Bread Pan, it is best to remove bread as soon as possible after completion of the Baking phase.





## MAKING DOUGH AND BAKING BREAD

Always use the freshest ingredients available. By carefully following the simple recipes that come with the Breadman® Bread Baker, you will be able to bake delicious bread every time.

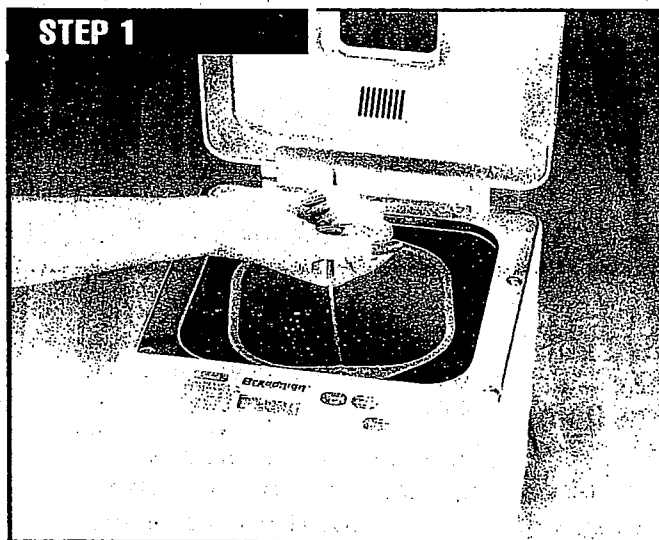

**STEP 1**  
Open the Lid and remove the Bread Pan.

Lift the Bread Pan, with a slight counter-clockwise turn. (The arrow marked "Remove" on the Bread Pan reminds you which way to turn the pan.)

The arrow marked "Front" on the Bread Pan reminds you which way to place the pan.

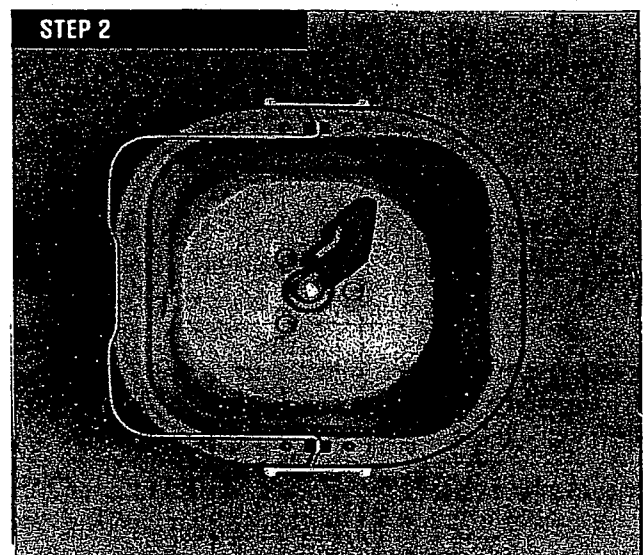

**STEP 2**  
Position the Kneading Paddle on the Drive Shaft as shown.

Match the flat side of the Drive Shaft to the flat part of the hole in the Kneading Paddle. Make sure the paddle is secure.



### STEP 3

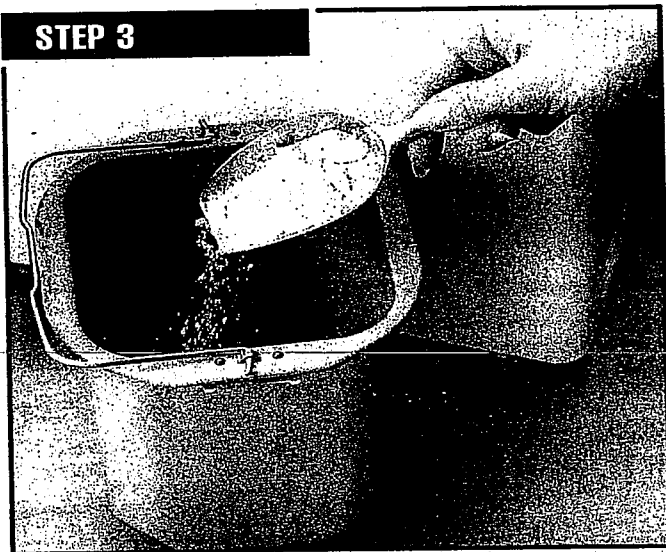

**Place the ingredients into the Bread Pan.**

For best results, add all liquid ingredients first. Then, add all dry ingredients **EXCEPT** yeast.

**ALWAYS ADD YEAST LAST.**

*Note: If your recipe contains salt, please add salt with liquid ingredients, keeping it away from the yeast. Salt may activate the yeast prematurely.*

### STEP 4

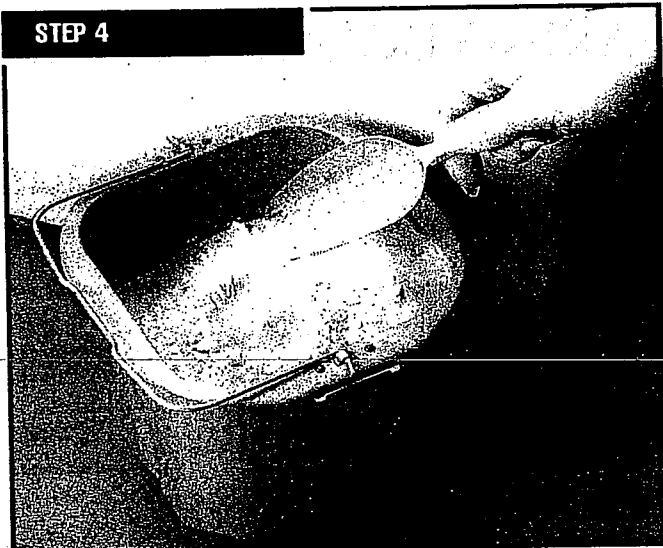

**Make a small indentation on top of the dry ingredients (not so deep it reaches the wet layer) and add the yeast to the indentation.**

This order of adding ingredients is important, especially when using the Timer, because it keeps the yeast away from the liquid ingredients until it's time to knead them together. (Liquid ingredients will activate the yeast.)

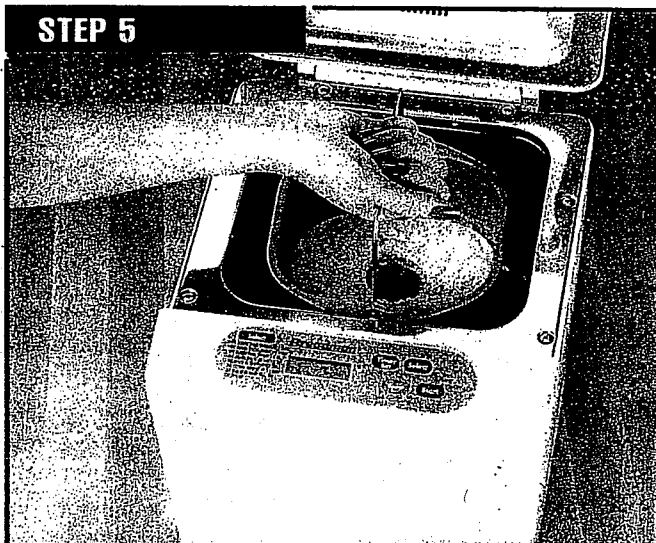

**Insert the Bread Pan in the Breadman.®**

Seat the Bread Pan as shown, then turn the Handle clockwise to secure it. (The arrow marked "Lock" reminds you which way to turn the Handle.

**Close the Lid and plug in the Breadman.®**

When you plug it in, the Breadman.® beeps once.

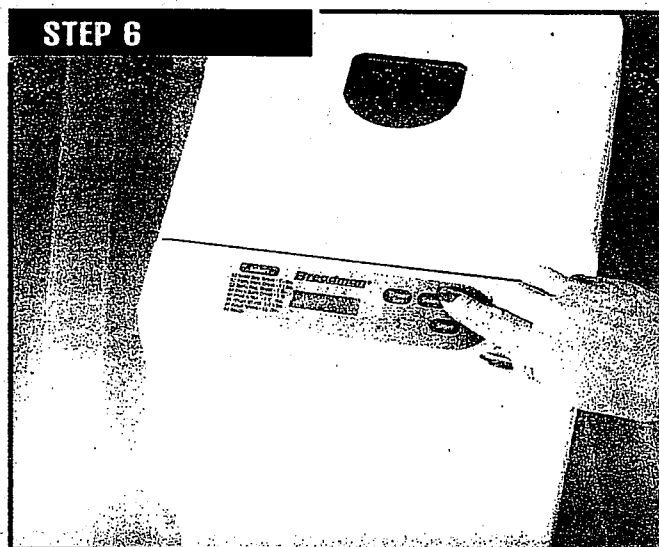

**Press the Select button to choose the cycle you want.**

Press Select once to choose "Basic (Dark Crust), 1-1/2 lbs." Each time you press Select again, the Display Window shows the next selection in this order:

3. Basic (Regular Crust, 1 lb.)
4. Basic (Dark Crust, 1 lb.)
5. Fruit & Nut (1 - 1-1/2 lbs.)
6. Whole Wheat (1 - 1-1/2 lbs.)
7. Rapid Bake
8. Dough

*\*For Whole Wheat cycle except Rapid cycle, which is 15 minutes, the mix initially rises for up to 30 minutes. No movement occurs in the pan. This is normal.*



If you forget to press the Select button, the "Basic (Regular Crust, 1-1/2 lbs.)" Cycle will **AUTOMATICALLY BE SELECTED.**

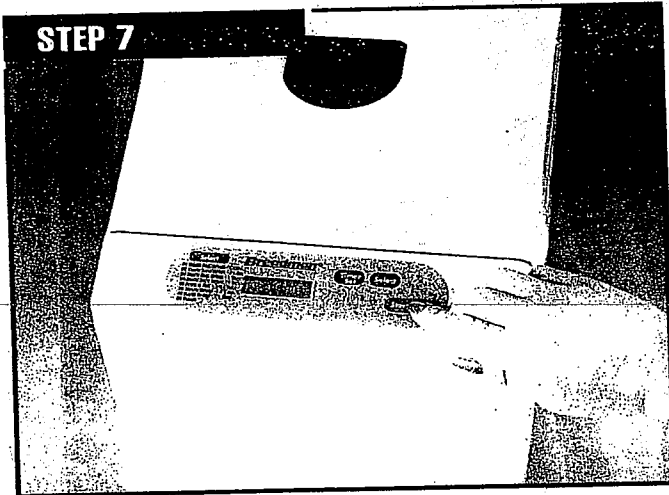

Press Start to begin the Kneading and/or Baking cycle.

First, the Breadman® mixes the ingredients for one minute. Then, it begins the Kneading process. During this process, the yeast begins to activate, and normally the Viewing Window begins to fog. (This will clear so you can see the progress of your loaf.) The Breadman® will stop Kneading after a few minutes to let the dough rise before baking.

If you plan to make bread or dough with raisins, dried fruit or nuts, add these ingredients when the Breadman® beeps several times, 5 min. before the end of the second Kneading cycle, in the Fruit & Nut function.

When baking bread, the machine will beep at the end of the baking cycle showing "END" in the Display Window. Although Breadman® has a 3-hour "Keep Warm" cycle, the baked bread is best removed from the appliance and the pan immediately after baking. Use oven mitts to carefully remove the bread pan.

If you are only making dough, Breadman® will beep. This indicates that the baking cycle is completed. Press the "STOP" button, remove dough and hand shape according to the recipe.

\*For all cycles except Rapid Bake and Dough, the machine preheats for 4 - 5 minutes before Kneading starts.

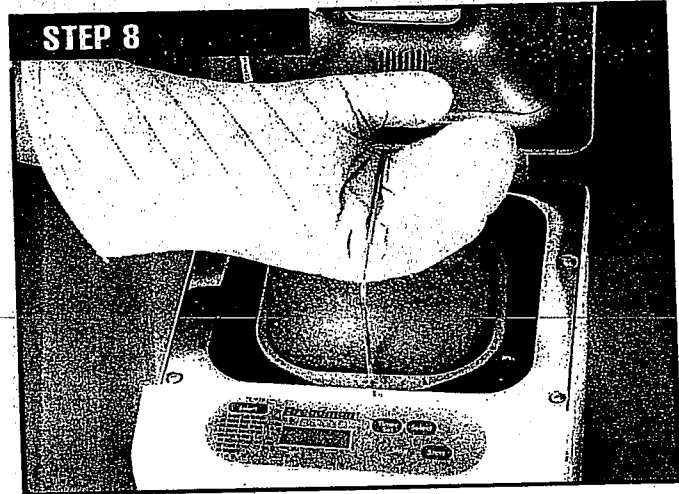

When your bread is done, the Breadman® will beep. This indicates that the Baking phase is completed. Press the "STOP" button, then put on your oven mitts and remove the Bread Pan.

Remember that the Bread Pan and your loaf are both very hot! Be careful not to place either on a tablecloth, plastic surface, or other surface that might scorch or melt.

#### *For all cycles except Dough:*

If the bread is not removed immediately after baking and if the "STOP" button is not pressed, a controlled Holding/Keep Warm cycle will begin and the machine will automatically shut off after 3 hours. While this will help prevent the bread from becoming soggy, *for best results*, remove bread immediately after Baking cycle is complete.

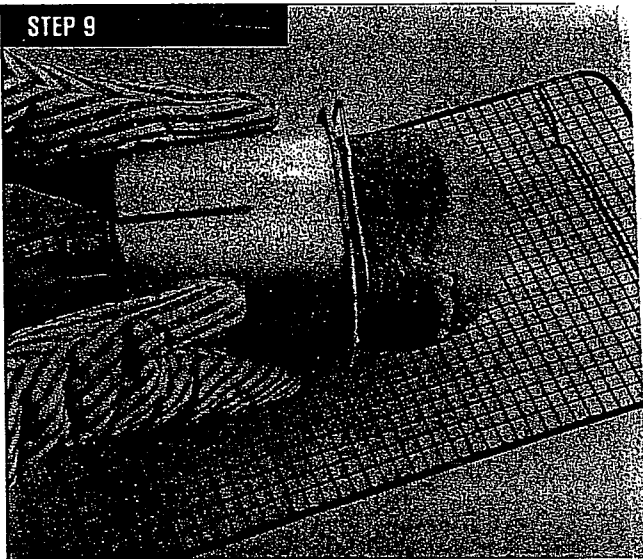

**STEP 9**

**Remove the loaf from the Bread Pan.**

Turn over the Bread Pan a few inches from the countertop and gently shake out the loaf. It's best to remove the loaf as soon as the machine is done baking.

Place the loaf on a wire rack or other ventilated cooling surface to cool. Bread should be cooled slightly (15 to 30 minutes) before it is sliced.

**If necessary, remove the Kneading Paddle from the loaf.**

Sometimes the Kneading Paddle will stick in a loaf of bread. If it does, use a non-metal utensil to gently remove it, taking care not to scratch the Kneading Paddle.

When you are done using the Breadman<sup>®</sup>, be sure to unplug it.



## USING THE TIMER

You can preset your Breadman® Bread Baker to cook bread from 4 hours to 13 hours in advance.

**NOTE:** Do not use the Timer if your recipe includes eggs, fresh milk or other ingredients that may spoil. The Breadman Timer can not be used for Rapid Bake or Dough cycles.

To preset your Breadman®, follow these steps:

1. Add the ingredients as usual, taking care not to let the yeast and liquid ingredients contact one another.
2. If your recipe contains salt, please add salt with liquid ingredients, keeping it away from the yeast. Salt may activate the yeast prematurely.
3. Close the Lid and plug it in.

Baking Cycle	Length of Baking Cycle	Baking Cycle	Length of Baking Cycle
Basic (Regular Crust, 1-1/2 lb.)	3:20 (3 hrs., 20 min.)	Fruit & Nut (1 - 1-1/2 lb.)	3:20
Basic (Dark Crust, 1-1/2 lb.)	3:20	Whole Wheat (1 - 1-1/2 lb.)	3:40
Basic (Regular Crust, 1 lb.)	3:10	Rapid Bake	2:50
Basic (Dark Crust, 1 lb.)	3:10		

4. Select the Baking Cycle you want. After the Start button is pressed, the Display Window will show the time needed to bake.
5. Press the Timer Set button once for each 10 minutes you want to add. The amount of time you set is shown in the Display Window.
  - To fast forward time, continually press the Timer Set button.
  - For example, if it is 8 o'clock and you want a loaf of bread ready at 1 o'clock, press the Timer button until the display reads 5:00, meaning it will finish baking in five hours.

**NOTE:** Actual baking times will not change.
6. Press Start to begin the Timer. The colon (:) in the time displayed begins to flash, letting you know the Timer is started. When the Display Window indicates "END," baking is completed.
7. If you make an error after you've activated the program and want to start over, press "STOP". The Timer will clear and you can begin again.



## USING THE TIMER *(continued)*

### **For Best Results**

- Take care to measure ingredients accurately, using a good set of measuring cups and spoons, or a good scale. Make sure to level all dry ingredients as you measure them. Inaccurate measuring could cause unexpected results in your loaf of bread.
  - In particular, be precise in measuring the water.
  - After placing all the ingredients in the Baking Pan, wait 10 minutes before pressing "Start," or use the Timer to add 10 minutes to the total processing cycle.
- \*See page 12 for detailed instructions.*
- Use fresh ingredients.
    - Since moisture is an enemy to flour, be sure to store your flour in an airtight container.
    - To keep your yeast active, store it in an airtight container in your refrigerator.
  - *Speaking of fresh* — when using the Timer, we recommend setting it for as short a time as possible. Because ingredients are partially combined in the Bread Pan, the dough may tend to deteriorate if left too many hours, especially on a warm or humid day.
  - Although you can preset the Breadman® for dough, we only recommend this for prepackaged mixes. Eggs and dairy products can easily spoil.
  - Keep the Lid closed during the Baking cycle. Opening it causes uneven baking.
  - After your bread has cooled completely, store it in a plastic bag or plastic wrap to prevent it from drying out.



## CLEANING INSTRUCTIONS

The Bread Pan and Kneading Paddle have non-stick surfaces that make cleaning easy.

1. After baking each loaf of bread, unplug the Breadman® and discard any crumbs.
2. Remove the Bread Pan from the Oven and the Kneading Paddle from the Bread Pan. Then, as needed, wash the Bread Pan and Kneading Paddle inside and out with warm, soapy water. Avoid scratching the non-stick surfaces.  
**DO NOT PUT THE PAN IN A DISHWASHER.**

If the Kneading Paddle is stuck to the Drive Shaft, pour warm water in the Pan to loosen it.  
**DO NOT USE EXCESSIVE FORCE.**

3. Wipe the inside of the Lid and Oven with a damp cloth or sponge. If any residue has scorched on the heating plate or elsewhere, wipe with a non-abrasive scrubbing pad and wipe clean.

Do not use vinegar, bleach, or harsh chemicals to clean the Breadman®.

Do not soak the Bread Pan for a long period of time — this could interfere with the free working of the Drive Shaft.

Be sure the machine is completely cooled before storing.

The inner casing contains the heating element and drive base. Therefore, when cleaning, **NEVER pour water, solvents or cleaning solutions into this area.**

### Caution

To avoid electric shock, unplug the Breadman® before cleaning!





## TROUBLE SHOOTING

Symptom	Possible Solutions
Display Window shows nothing	Make sure the machine is plugged in. If nothing appears in the Display Window, unplug and plug in again.
START button doesn't start the machine	Make sure the machine is plugged in. If nothing appears in the Display Window, press Select to choose your Baking cycle. (You must select a Baking cycle before pressing Start.) If the baking area is too hot, the Breadman® will not start because of an automatic safety feature. Remove the Bread Pan with your ingredients, and wait until the Breadman® cools down — about 20 minutes — before starting a new loaf.
Can't set the Timer	If you selected either the Rapid Bake or Dough cycle, you should not use the Timer. This is because the ingredients should be processed immediately for these cycles.
After starting, the Display Window flashes "H:E"	If the bread machine is too hot, it will not start because of an automatic safety feature. Remove the Pan and let the bread machine cool down until "H:E" disappears and the selection reappears. You may then start the cycle.
The bread machine doesn't mix the ingredients	On preheating the (:) in the Time Display flashes and Kneading Paddle will not move. There is a 4 - 5 min. rest period on some of the cycles in which there will be no movement in the pan for 4 - 5 min. If the Kneading Paddle does not operate after this period of time, check to see if the Kneading Paddle is engaged in the machine correctly.
The Breadman® stopped and "000" flashes	This happens if you press the Stop button, if you unplug the machine, or if there is a power outage. In each case, the Breadman® can't be restarted for this cycle. Discard the contents of the Bread Pan and start again with new ingredients.



## TROUBLE SHOOTING (continued)

Symptom	Possible Solutions
The bread machine does not bake the bread	The Dough program was selected. To bake the bread, choose the appropriate program for baking bread.
Bread has an offensive odor	Check to be sure you added the correct amount of yeast. Measure carefully — too much yeast will cause an unpleasant odor and may cause the loaf to rise too high. Be sure to use only fresh ingredients.
Baked bread is soggy or the bread's surface is sticky	Remove the bread from the Bread Pan as soon as it is done baking. Leaving it in the pan allows condensation to collect on the sides touching the pan. Also be sure to cool the loaf on a wire rack; cooling it on a countertop causes the side next to the counter to become soggy.
The Kneading Paddle was stuck in the bread	Make sure the Kneading Paddle is mounted properly before adding ingredients to the Bread Pan and baking. Sometimes denser or crustier loaves of bread may pull the Kneading Paddle out with them when you remove the loaves after baking. When this happens, use a non-metal utensil and gently remove the blade from the bottom of the loaf.
The bread rose too high	Make sure not to add too much yeast, water or flour. Too much of any of these may cause the loaf to rise more than it should.
The bread didn't rise enough	Did you add enough yeast, water or sweetener? Make sure to add ingredients in the proper order: liquids, dry ingredients, yeast. Make sure yeast doesn't get wet until the Breadman® mixes the ingredients together. <i>Note: Typically, bread made with whole grain flours will not rise as high as bread made with refined flours.</i>



## TROUBLE SHOOTING *(continued)*

<b>Symptom</b>	<b>Possible Solutions</b>
The bread didn't rise at all	Make sure yeast is not left out. Also check the date code on the yeast and that it is always the last ingredient put into the pan. Make sure the yeast doesn't come into contact with salt or any liquid ingredients.
The dough looks like batter, or the dough ball is still sticky, not smooth and round	During the Kneading process, add 1 tablespoon of flour at a time, letting it mix in well. For most breads, your dough ball should become round, smooth, not sticky to the touch, and should bounce back when you press it with your finger.
The dough ball is lumpy or too dry	During the Kneading process, add 1 tablespoon of water at a time, letting it mix in well.
The bread caved in	Make sure liquids are measured correctly. Next time, reduce your liquids by 2 tablespoons. If you're using fruits or vegetables, make sure they are well drained.
:END: displays	The Baking cycle is completed.



## SPECIFICATIONS

Model	TR441
Power Requirements	120V AC 60 Hz.
Power Consumption	Heater: 150 watts Motor: 100 watts
Capacity (Flour)	2 cups for 1 lb. loaf; 3 cups for 1-1/2 lb. loaf
Timer Range	4 hours (4:00) to 13 hours (13:00)
Holding Cycle	If bread is not removed after Baking cycle, the Breadman® shifts into a controlled rate Keep Warm cycle which reduces the bread temperature gradually. Shuts off after 3 hours.*

\*Except for Dough function.



# NOTES

A series of horizontal lines for writing, consisting of 22 lines spaced evenly down the page.



# NOTES

A series of horizontal lines for writing notes, consisting of approximately 22 lines.

# ONE-YEAR LIMITED WARRANTY

This Salton/MAXIM product warranty extends to the original consumer purchaser of the product.

**Warranty Duration:** This product is warranted to the original consumer purchaser for a period of one (1) year from the original purchase date except for the Bread Pan and Kneading Paddle which are warranted for 90 days.

**Warranty Coverage:** This product is warranted against defective materials or workmanship. This warranty is void if the product has been damaged by accident, in shipment, unreasonable use, misuse, neglect, improper service, commercial use, repairs by unauthorized personnel or other causes not arising out of defects in materials or workmanship. This warranty is effective only if the product is purchased and operated in the USA, and does not extend to any units which have been used in violation of written instructions furnished by Salton/MAXIM Housewares, Inc., or to units which have been altered or modified or to damage to products or parts thereof which have had the serial number removed, altered, defaced or rendered illegible. Wear and tear for Bread Pans and Paddles is not considered a manufacturer's defect.

**Warranty Disclaimers:** This warranty is in lieu of all warranties expressed or implied and no representative or person is authorized to assume for Salton/MAXIM Housewares, Inc. any other liability in connection with the sale of our products. There shall be no claims for defects or failure of performance or product failure under any theory of tort, contract or commercial law including, but not limited to, negligence, gross negligence, strict liability, breach of warranty and breach of contract.

**Warranty Performance:** During the above one-year warranty period, a product with a defect will be either repaired or replaced with a reconditioned comparable model (at Salton/MAXIM's option) when the product is returned to the Salton/MAXIM facility. The repaired or replacement product will be in warranty for the balance of the one-year warranty period and an additional one-month period. No charge will be made for such repair or replacement.

## Service and Repair

Should the appliance malfunction, you should first call toll-free 1-800-233-9054 between the hours of 9:00 am and 5:00 pm Central Standard Time and ask for CONSUMER CUSTOMER SERVICE stating that you are a consumer with a problem.

**In-Warranty Service:** For an appliance covered under the warranty period, no charge is made for service or postage. Call for pre-paid return mailing label. (U.S. Customers Only)

**Out-of-Warranty Service:** A flat rate charge by model is made for out-of-warranty service. Include \$15.00 for return shipping and handling.

Salton/MAXIM cannot assume responsibility for loss or damage during incoming shipment. For your protection, carefully package the product for shipment and insure it with the carrier. Be sure to enclose the following items with your appliance: any accessories related to your problem; your full return address and daytime phone number; a note describing the problem you experienced; a copy of your sales receipt or other proof of purchase to determine warranty status. C.O.D. shipments cannot be accepted.

Return the appliance to:

ATTN: Repair Department  
Salton/Maxim Housewares, Inc.

708 SOUTH MISSOURI ST.

MACON, MO 63552

For more information on Salton/MAXIM products:

visit our website: URL <http://www.breadman.com> or E-mail us at [SALTON550@aol.com](mailto:SALTON550@aol.com)

...the ... of ...

...the ... of ...

...the ... of ...

...the ... of ...

...the ... of ...

...the ... of ...

...the ... of ...

...the ... of ...



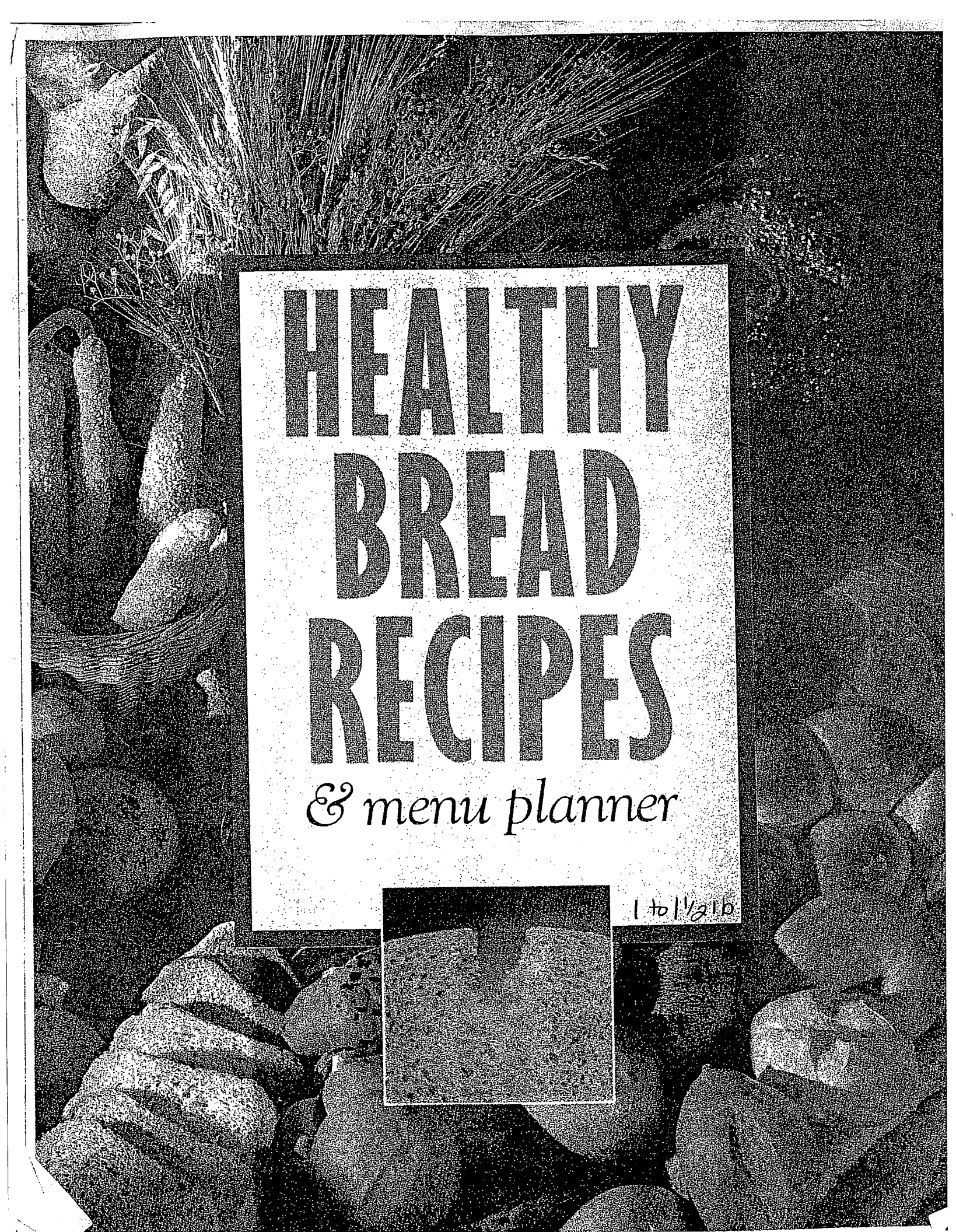

# HEALTHY BREAD RECIPES

*& menu planner*

1 to 1 1/2 lb.

# HEALTHY BREAD RECIPES

*& menu planner*

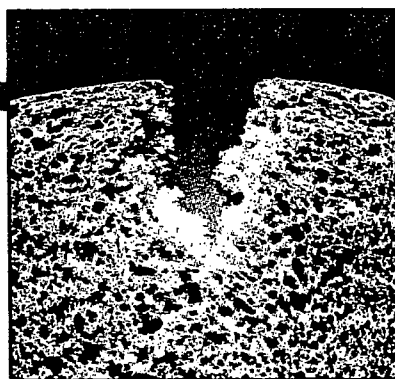

## IMPORTANT

### *Please Read*

The information in this booklet is intended to increase your knowledge of whole grains and fresh bread baking, and by no means is it intended to diagnose or treat an individual's health problems or ailments. The information given is not medical advice, nor is it presented as medical advice. Before starting any type of diet or medical treatment you should consult your own health care practitioner.



## CONTENTS

1

Introduction

2

Health Benefits of Whole Grain Breads

3

Recipe Ingredients

3

Grain Glossary

5

Sample Menus Using Whole Grain Breads

6

Recipes

11

Questions and Answers



## INTRODUCTION

Since biblical times, bread has been considered “the staff of life.” Today whole grains are still recognized as the foundation of a nutritious diet. The USDA’s Food Guide Pyramid, the new food guideline that replaces the old four food groups, recommends that whole grains comprise nearly 50 percent of our daily calories. According to these guidelines, we should eat six to eleven servings of whole grains every day.

This USDA recommendation is easy to follow with the Breadman™ Automatic Bread Baker. Specially designed to handle whole grains, the Breadman bakes up deliciously healthy nutrition with just the touch of a button. And you can guarantee that your family gets only the freshest, most health-giving breads because you are in control. You choose the flour, you select the sweetener (if any), and you decide when the baking process will start. Whenever you desire, you can have an aromatic loaf of just-baked bread, bursting with all the goodness of whole grains and containing no hidden additives, saturated fats, excess sodium or refined sugars.

Let this Recipe and Menu Planner be the beginning of your health-enhancing adventures with bread baking. The suggestions provided here are just that—suggestions. Please feel free to use your imagination and enjoy experimenting with your favorite ingredients.



## HEALTH BENEFITS OF WHOLE GRAIN BREADS

Refined grains, and the products made from them, have literally been stripped of their natural goodness. Commonly listed as *white flour*, *wheat flour* or even *enriched flour*, refined grains are almost devoid of the fiber and important nutrients that were intact in the original grain. Besides being processed, white flour is often bleached to achieve that snow-white appearance. All this adulteration has changed a wholesome food into a food fragment containing little nutritional benefit and very little character.

Fiber-rich whole grains and whole grain flours have been the focus of many scientific studies demonstrating that they reduce the risk of diverticulosis, colon and rectal cancer, and atherosclerosis. Diets containing adequate fiber inherently tend to be lower in fat and calories, especially saturated fat and cholesterol, which may contribute to the reduced risk factor.

Fiber is the primary reason that whole grain breads and other products are so satisfying to eat. Fiber is filling, and because it contains so few calories it is an excellent part of the low-fat, high complex carbohydrate diet recommended for better health.



## RECIPE INGREDIENTS

Bread recipes begin with a very basic set of ingredients: water, flour, salt and yeast. To this short list, you can add a variety of interesting and delicious ingredients that will give your breads the individuality you are looking for. Seeds, nuts, nut butters, dried fruits, raisins, dates, apples, berries, herbs, spices, carob powder, vegetables and bran are just a few of the many ingredients you can use to create hundreds of unique and flavorful breads.

Purchase fresh ingredients whenever possible for the best taste and results. Dried foods, such as fruits, vegetables, herbs and spices will keep for a virtually unlimited time if stored in a cool, dry environment. Store produce, oils, whole grain flours and other perishable foods in the refrigerator for longer life and retention of flavor. Glass and hard plastic containers with tight fitting lids are preferable for storing most foods; they keep the aromas in but do not expose the foods to the potentially harmful ingredients found in some plastic containers. Plastic may absorb strong odors, so for spicy or pungent ingredients, always use glass.

You will probably be able to find most, if not all, of the ingredients needed for baking healthy breads at your supermarket; consumer demand has helped many grocers become more health conscious. If some of the ingredients are not available yet in your grocery store, your health food store is certain to stock them.

For the widest range of nutrients and a diversity of wonderful flavors and textures, try baking with a variety of the healthy grains listed below.

## GRAIN GLOSSARY

**Amaranth** This petite golden grain is moving quickly from the "unusual" grain category to one of mainstream acceptance. A mainstay in the diet of the Aztecs, amaranth was considered a strength-giving food, probably due to its high protein profile. Both the grain and its flour offer a distinct flavor when added to your favorite bread recipes.

**Barley** This grain has a hearty, earthy flavor and produces a dense loaf of bread due to its low gluten content. Barley is a good substitute for white flour in recipes, but should be cut with a lighter flour when several cups are being used at a time.



**Buckwheat** Technically not a grain, buckwheat is really the fruit of a plant related to rhubarb. Its flour (ground buckwheat seed) and groats are both useful for unique bread making. The flavor has been described as a combination of rosemary and green tea.

**Corn** The only grain eaten fresh as a vegetable, corn (also known as maize) is available in a wide variety of colors. Judge the freshness of cornmeal and flour from its sweet and delicate flavor. Blue cornmeal, a beautiful hue when dry, becomes a purplish color when cooked.

**Kamut** This "ancient" wheat grain is available as a whole grain, rolled grain, flour and cereal. People who are wheat sensitive have reported a tolerance to kamut products, though this is still being investigated.

**Millet** Commonly used to feed birds, millet lends a delightful crunch when added in whole grain form to bread recipes. People who are allergic to other grains have had luck with millet. It is considered to be the most digestible grain around.

**Oat** Rolled oats and oat flour are welcome additions to almost any bread recipe. Their delicately light texture and flavor embody the pleasures of home-baked goodness. Grind your own oat flour by chopping oat flakes in the blender until they reach the desired consistency.

**Quinoa** This recently rediscovered grain is found in whole form, in flour and in prepared products like pasta. When added to bread recipes, it imparts an earthy flavor matched by no other grain, and it packs a protein punch.

**Rye** This cold-weather grain is famous for its use in savory pumpernickel and caraway seed-rich rye breads. Rye has very little gluten and rises with the assistance of wheat flours.

**Spelt** Another of the "ancient" super grains, spelt has been reintroduced with resounding success. Use it in bread recipes in place of wheat for a slightly nutty flavor.

**Wheat** Wheat and whole wheat flour are the basis for most bread recipes. The gluten content of wheat provides the strength and resiliency necessary for a high and sturdy loaf.





## SAMPLE MENUS USING WHOLE GRAIN BREADS

### Cholesterol-Free Menu Suggestions

#### *Breakfast*

Fresh orange-grapefruit juice  
Slice Honey Granola and  
Yogurt Bread (page 7), toasted, with  
1 tablespoon peanut butter  
Banana

#### *Mid-Morning*

Slice Oatmeal Bread (page 6)  
with 1 tablespoon apple butter

#### *Lunch*

Sandwich with hummus, celery,  
sprouts, tomato, cucumber  
on Sprouted Wheat Berry  
Bread (page 9)

#### *Afternoon Break*

Fresh fruit or veggie sticks

#### *Dinner*

Baked potato with skin,  
topped with salsa  
Black bean and rice salad,  
topped with chilies and tomatoes  
Slice Pumpnickel Bread (page 8)  
Raw mixed vegetable salad

#### *Evening Snack*

Air-popped popcorn  
or fresh fruit

### Menu Suggestions with Fish and Dairy

#### *Breakfast*

Fresh pineapple juice  
Slice Orange Apple Bread  
(page 6), toasted  
1/2 cup plain low- or non-fat yogurt

#### *Mid-Morning*

Slice Rolled Grains Bread  
(page 8)

#### *Lunch*

Wild greens salad with  
rice vinegar dressing  
Slice Dill Rye Bread (page 9)  
Minestrone soup  
Steamed or stir-fried vegetables

#### *Afternoon Break*

Fresh tomato-cucumber-parsley  
juice, with a dash of hot sauce  
or lemon juice if desired

#### *Dinner*

Poached fish with lemon  
Slice Oat Bran Bread (page 7)  
Steamed asparagus and carrots  
Fresh spinach salad topped with  
Croutons (page 9)

#### *Evening Snack*

Low-fat baked corn chips  
with salsa

**Note:** These bread recommendations are suggestions only. Your favorite bread recipes may be substituted in any of the above meal plans.



## RECIPES

The following recipes, excerpted from *The Breadman's Healthy Bread Book* by George Burnett (New York: William Morrow & Company, Inc., 1992), are divided into two types: *Transition* and *Elite*. Transition recipes use unbleached all-purpose white flour and also include whole grain flours. These breads are meant to help you bridge the gap from baking with only white flour to baking with only whole grain flours. Elite recipes use whole grains only and are nutritionally superior. Elite recipes include some ingredients that might require a visit to your health food store.

For best baking results, use an accurate scale and double check measurements by weighing ingredients.

### Oatmeal Bread

#### *Transition*

*Makes a 1-1/2 pound loaf*

1-1/8 cups (9 ounces) warm water	3/4 cup (3-1/2 ounces) whole wheat flour
1-1/2 tablespoons canola oil	1/2 cup (1-1/2 ounces) rolled oats)
1 tablespoon maple syrup	2 tablespoons powdered milk
2-1/4 cups (10-3/4 ounces) unbleached all-purpose flour	1-1/2 teaspoons salt
	2-1/2 teaspoons active dry yeast

Put all the ingredients into the Bread Pan in the order listed. Select Basic Wheat cycle, Light setting, on your Breadman machine. Press Start.

### Orange Apple Bread

#### *Transition*

*Makes a 1-1/2 pound loaf*

3/4 cup (6 ounces) warm water	3/4 cup (3-1/2 ounces) whole wheat flour
1-1/2 tablespoons canola oil	2 tablespoons powdered milk
1-1/2 tablespoons honey	1-1/2 teaspoons salt
1 teaspoon vanilla extract	1 teaspoon cinnamon
1/4 cup (2 ounces) orange-apple pulp	2-1/2 teaspoons active dry yeast
Grated zest of 2 oranges	2/3 cup (3 ounces) chopped nuts, such as walnuts
2-1/4 cups (10-3/4 ounces) unbleached all-purpose flour	



Put all ingredients (except nuts) into the Bread Pan in the order listed. Select Basic Wheat cycle, Medium setting, on your Breadman machine. Press Start. Add nuts when the machine beeps, about 12 minutes after starting.

### Honey Granola and Yogurt Bread *Transition*

*Makes a 1-1/2 pound loaf*

1/2 cup (4 ounces) warm water	3/4 cup (3-1/2 ounces) whole wheat flour
1-1/2 tablespoons canola oil	2 tablespoons powdered milk
3 tablespoons honey	1-1/2 teaspoons salt
1/2 cup (4 ounces) plain low-fat yogurt	2-1/2 teaspoons active dry yeast
1/2 cup (2-1/2 ounces) granola	
2-1/4 cups (10-3/4 ounces) unbleached all-purpose flour	

Put all ingredients into the Bread Pan in the order listed. Select Basic Wheat cycle, Light setting, on your Breadman machine. Push Start.

### Oat Bran Bread *Elite*

*Makes a 1-1/2 pound loaf*

1-1/8 cup (9 ounces) warm water	1/3 cup (1-1/2 ounces) oat bran
1-1/2 tablespoons canola oil	1/3 cup (3/4 ounce) rolled oats
2 tablespoons honey	2 tablespoons gluten flour
1/2 teaspoon liquid lecithin	3 tablespoons powdered whey
1-1/2 cups (7 ounces) whole wheat flour	1-1/2 teaspoons fine sea salt
3/4 cup (3-1/2 ounces) oat flour	2-1/2 teaspoons active dry yeast

Put all ingredients into the Bread Pan in the order listed. Select Basic Wheat cycle, Light setting, on your Breadman machine. Push Start.



## Rolled Grains Bread

*Elite*

*Makes a 1-1/2 pound loaf*

1-1/8 cup (9 ounces) warm water	3/4 cup (3-1/2 ounces) rolled multi-grain cereal
1-1/2 tablespoons canola oil	2 tablespoons gluten flour
1-1/2 teaspoons honey	3 tablespoons powdered whey
1 tablespoon unsulphured molasses	1-1/2 teaspoons fine sea salt
1/2 teaspoon liquid lecithin	2 teaspoons active dry yeast
3 cups (14 ounces) whole wheat flour	

Put all the ingredients into the Bread Pan in the order listed. Select Basic Wheat cycle, Light setting, on your Breadman machine. Push Start.

## Pumpnickel Bread

*Elite*

*Makes a 1-1/2 pound loaf*

1-1/4 cups (10 ounces) warm water	3 tablespoons gluten flour
1 tablespoon canola oil	4 tablespoons powdered whey
1 tablespoon unsulphured molasses	1 tablespoon caraway seeds
1/2 teaspoon liquid lecithin	3 tablespoons carob powder
2 cups (9-1/2 ounces) whole wheat flour	1-1/2 teaspoons fine sea salt
1 cup (4-3/4 ounces) rye flour	2-1/2 teaspoons active dry yeast

Put all ingredients into the Bread Pan in the order listed. Select European cycle on your Breadman machine. Press Start.

## Apricot Nut Bread

*Elite*

*Makes a 1-1/2 pound loaf*

1 cup (8 ounces) warm water	3 tablespoons powdered whey
1 tablespoon canola oil	1-1/2 teaspoons fine sea salt
1-1/2 tablespoons honey	2-1/2 teaspoons active dry yeast
1/2 teaspoon liquid lecithin	1/2 cup (4 ounces) unsulphured, dried apricots, chopped
2 tablespoons all-fruit apricot preserves	1/2 cup (2 ounces) pecans, chopped
3 cups (14 ounces) whole wheat flour	
2 tablespoons gluten flour	



Put all the ingredients (except apricots and pecans) into the Bread Pan in the order listed. Select Fruit and Nut cycle on your Breadman machine. Press Start. Add the apricots and pecans when the machine beeps, about 12 minutes after starting.

### **Sprouted Wheat Berry Bread**

*Elite*

*Makes a 1-1/2 pound loaf*

3/4 cup (3 ounces) sprouted wheat berries	3 cups (14 ounces) wheat flour
1-1/8 cup (9 ounces) warm water	2 tablespoons gluten flour
1-1/2 tablespoons canola oil	3 tablespoons powdered whey
1-1/2 tablespoons barley malt syrup	1-1/2 teaspoons fine sea salt
1/2 teaspoon liquid lecithin	1-1/2 teaspoons active dry yeast

Put all ingredients into the Bread Pan. Select Basic Wheat cycle, Light setting, on your Breadman machine. Press Start.

### **Dill Rye Bread**

*Elite*

*Makes a 1-1/2 pound loaf*

1 cup (8 ounces) warm water	2 tablespoons gluten flour
1-1/2 tablespoons canola oil	3 tablespoons powdered whey
1-1/2 tablespoons unsulphured molasses	1 teaspoon dill weed
1-1/2 tablespoons honey	2 teaspoons caraway seeds
1/2 teaspoon liquid lecithin	1-1/2 teaspoons fine sea salt
2-1/2 cups (12 ounces) whole wheat flour	2 teaspoons active dry yeast
1 cup (4-3/4 ounces) rye flour	

Put all ingredients in the Bread Pan in the order listed. Select Basic Wheat cycle, Light setting, on your Breadman machine. Press Start.

### **Croutons**

Cube your favorite Breadman bread into 1/2- to 1-inch cubes. Bake slowly in a warm oven (300°F) until crisp all the way through, about 20 minutes. Store in an airtight jar, in a cool dry place. Use to top salads, soups and casseroles.



The Breadman's World-Famous, All-Natural,  
No-Butter Cinnamon Rolls  
*Elite*

Makes 12 rolls

**Dough**

3/4 cup plus 2 tablespoons (7 ounces) warm water	3 tablespoons powdered whey
1-1/2 tablespoons canola oil	2 teaspoons gluten flour
1-1/2 tablespoons honey	2 teaspoons powdered egg substitute
1/4 teaspoon liquid lecithin	3/4 teaspoon fine sea salt
2 cups (9-1/2 ounces) whole wheat flour	1-1/2 teaspoons active dry yeast

**Glaze**

1/4 cup almond butter	1/2 cup honey
1/4 cup canola oil	1/2 cup powdered whey

**For sprinkling on glaze**

2 teaspoons cinnamon	1/3 cup raisins or chopped nuts (optional)
----------------------	---

Put all the dough ingredients into the Bread Pan in the order listed. Select Dough setting on your Breadman machine. Press Start. When the machine beeps, after 1 hour and 20 minutes, remove the dough. Turn off machine.

Place dough on a lightly floured counter or cutting board. Flatten it out slightly and roll it into a 10-by-12-inch rectangle. Stir glaze ingredients together until smooth. Warm gently in a saucepan for a couple of minutes if too stiff. Spread half the glaze over the rectangle of dough, leaving a narrow border all around. Sprinkle cinnamon and, if desired, raisins or chopped nuts over the glaze. Beginning at one long side, roll dough into a cylinder and pinch the seam to seal. Cut rolled dough into twelve 1-inch slices.

Using canola oil, lightly oil a 10-inch round cake pan. Spread remaining glaze mixture over bottom of prepared pan. Set rolls in pan on top of glaze and cover with plastic or damp cloth. Let rolls rise in a warm place until doubled in volume, about 1 hour.

Preheat oven to 350°F. Set pan on a baking sheet and bake on the center rack of the oven for 15 to 20 minutes. (Glaze that bubbles over the pan in the oven will spill onto baking sheet.) Invert pan onto a serving platter and let the glaze drip down sides of the rolls. Scrape any remaining glaze from pan onto rolls. Serve warm.



## QUESTIONS AND ANSWERS

*How much bread should I eat a day?*

The USDA recommends that we eat 6 to 11 servings of complex carbohydrates every day. This recommendation is easy to reach when whole grain breads, other whole grain products, pastas, and a variety of legumes are part of your diet. (One slice of whole grain bread equals one serving of a complex carbohydrate.) Enjoy a slice or two of whole grain bread at every meal and incorporate them into snacks.

*Isn't bread a fattening food?*

The most fattening part of bread is the high-fat spread applied to the top! Bread is made primarily of wheat or another grain flour and is very low in fat. Other ingredients only make up a fraction of the entire loaf, so each slice is a lowfat treat. Hearty whole grain flour breads will be lower in fat and calories than a sweet, refined flour bread.

*What is the healthiest bread?*

A bread is only as healthy as its ingredients. Whole grain flours, fiber, nuts, seeds and dried fruit are all wholesome ingredients that make for healthy bread. Avoid ingredients that are dense in calories but offer little nutritional value, like refined flours, candied fruits, refined sugars and an abundance of fats or oils.

*Is all bread a good source of fiber?*

Not all breads automatically provide a lot of fiber. If refined flours are used, most of the fiber has been removed. Fiber is naturally present in whole grain flours and other ingredients like seeds, nuts, bran and germ.

*What if someone has a wheat allergy or sensitivity? What kinds of grains can they eat?*

Some people cannot digest the wheat protein called gluten. Gluten is mainly found in wheat and rye, but is also present to some extent in oats and barley. Persons with celiac sprue must carefully avoid all gluten. Persons who are merely gluten-sensitive can tolerate a low-gluten instead of gluten-free diet. Generally speaking, most gluten-sensitive people can tolerate a small amount of gluten, particularly when gluten-containing foods are eaten infrequently (once every four days, for instance). Delicious low-gluten and gluten-free grains include amaranth, buckwheat, corn, millet, oats, quinoa and rice. In addition, many natural food stores now stock products that are gluten-free and are made from corn flour, cornmeal, cornstarch, lima bean flour, potato flour, rice, rice flour, soy flour and tapioca.

***Please Note:***

***All recipes listed are for 1½ lb. loaves.***

To prepare a 1 pound loaf, simply *reduce* all of the ingredients by a ratio of 1/3.

To prepare a 2 pound loaf, simply *increase* the ratio of ingredients by 1/3.



