

This Owner's Manual is provided and hosted by [Appliance Factory Parts](http://www.ApplianceFactoryParts.com).

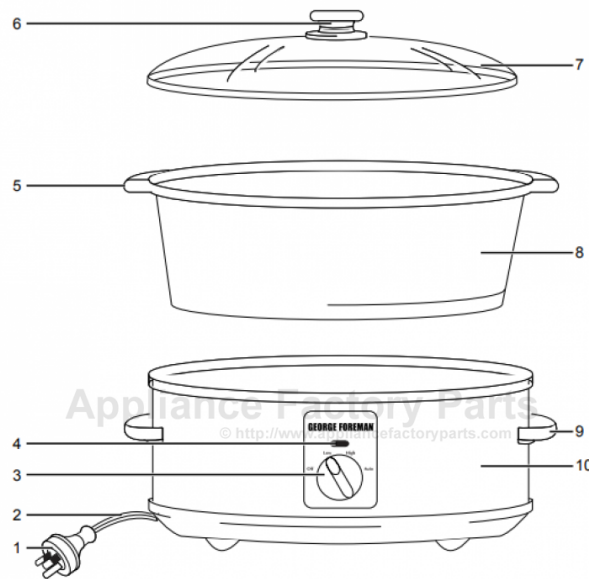

# George Foreman GFSC35BLK Owner's Manual

[Shop genuine replacement parts for George Foreman  
GFSC35BLK](#)



- |                                   |                                |
|-----------------------------------|--------------------------------|
| 1. Power plug                     | 6. Knob                        |
| 2. Power supply cord              | 7. Tempered glass lid assembly |
| 3. OFF/LOW/HIGH/AUTO Control Dial | 8. Ceramic bowl                |
| 4. Power indicator light          | 9. Base handles                |
| 5. Liner handles                  | 10. Stainless steel base unit  |

[Find Your George Foreman Cooker Parts - Select From 12 Models](#)

----- Manual continues below -----

# GEORGE FOREMAN®

HEALTHY COOKING



## *Slow Cooker*

**GFSC35BLK & GFSC60BLK**

# INSTRUCTIONS & WARRANTY

GFSC60BLK\_GFSC35BLK\_IB\_RB2\_091111

## Spectrum Brands Australia Pty Ltd

Locked Bag 3004 Braeside

Victoria 3195 Australia

### Customer Service in Australia

TollFree: 1800 623 118

Email: [info@spectrumbrands.com.au](mailto:info@spectrumbrands.com.au)

Website: [www.spectrumbrands.com.au](http://www.spectrumbrands.com.au)

## Spectrum Brands New Zealand Ltd

PO Box 9817 Newmarket

Auckland 1149 New Zealand

### Customer Service in New Zealand

TollFree: 0800 736 776

Email: [service@spectrumbrands.co.nz](mailto:service@spectrumbrands.co.nz)

Website: [www.spectrumbrands.co.nz](http://www.spectrumbrands.co.nz)

## Spectrum Brands Australia Pty Ltd and Spectrum Brands New Zealand Ltd



### Warranty Against Defects

In this warranty:

**Australian Consumer Law** means the Australian consumer law set out in Schedule 2 to the Competition and Consumer Act 2010;

**CGA** means the New Zealand Consumer Guarantees Act 1993;

**Goods** means the product or equipment which was accompanied by this warranty and purchased in Australia or New Zealand, as the case may be;

**Manufacturer, We** or **us** means:

1. for Goods purchased in Australia, Spectrum Brands Australia Pty Ltd ABN, 78 007 070 573; or
2. for Goods purchased in New Zealand, Spectrum Brands New Zealand Ltd, as the case may be, contact details as set out at the end of this warranty;

**Supplier** means the authorised distributor or retailer of the Goods that sold you the Goods in Australia or in New Zealand; and

**You** means you, the original end-user purchaser of the Goods.

1. Our goods come with guarantees that cannot be excluded under the Australian Consumer Law, or the CGA. You are entitled to a replacement or refund for a major failure and compensation for any other reasonably foreseeable loss or damage. You are also entitled to have the goods repaired or replaced if the goods fail to be of acceptable quality and the failure does not amount to a major failure.
2. The benefits provided by this Warranty are in addition to all other rights and remedies in respect of the Goods which the consumer has under either the Australian Consumer Law or the CGA. The original purchaser of the Goods is provided with the following Warranty subject to the Warranty Conditions:
3. We warrant the Goods for all parts defective in workmanship or materials from the date of purchase (**Warranty Period**), for the period of:-
  - (a) Two (2) years for Russell Hobbs products (see product packaging for details)
  - (b) Two (2) years with five (5) year motor warranty for Russell Hobbs products (see product packaging for details)
  - (c) Limited Lifetime, Ten (10) years for Russell Hobbs cookware.
  - (d) One (1) year for George Foreman, iRobot, Westinghouse, Black & Decker and Spectrum Brands products.

If the Goods prove defective within the Warranty Period by reason of improper workmanship or material, we may, at our own discretion, repair or replace the Goods without charge.

## Warranty Conditions

4. The Goods must be used in accordance with the manufacturer's instructions. This Warranty does not apply should the defect in or failure of the Goods be attributable to misuse, abuse, accident or non-observance of manufacturer's instructions on the part of the user. As far as the law permits, the manufacturer does not accept liability for any direct or consequential loss, damage or other expense caused by or arising out of any failure to use the Goods in accordance with the manufacturer's instructions.
5. Exhaustible components (such as batteries, filters and brushes) of the Goods are included under this Warranty only where there is a defect in workmanship or materials used.
6. The warranty granted under clause 3 is limited to repair or replacement only.
7. Any parts of the Goods replaced during repairs or any product replaced remain the property of the manufacturer. In the event of the Goods being replaced during the Warranty Period, the warranty on the replacement Goods will expire on the same date as for the Warranty Period on the original Goods which are replaced.
8. In order to claim under the warranty granted under clause 3 you must:
  - (a) Retain this warranty with your receipt/proof of purchase; and
  - (b) Return the Goods to us at the relevant address or to the Supplier by prepaid freight within the Warranty Period accompanied with (i) the legible and unmodified original proof of purchase, which clearly indicates the name and address of the Supplier, the date and place of purchase, the product name or other product serial number and (ii) this warranty.
9. This warranty is immediately void if:
  - (a) Any serial number or appliance plate is removed or defaced;
  - (b) The Goods have been serviced or otherwise repaired by a person not authorised to do so by us or where non approved replaced parts are used.
10. The Goods are designed for domestic use only. A limited 90-day Warranty applies to any industrial or commercial use of the Goods. The Goods must be connected to the electrical voltage requirements as specified in the ratings label located on the Goods.
11. This warranty does not cover the cost of claiming under the warranty or transport of the Goods to and from the Supplier or us.
12. This warranty is only valid and enforceable in Australia against Spectrum Brands Australia Pty Ltd and in New Zealand against Spectrum Brands New Zealand Ltd.

Contact us or the Supplier for further details.

### Register your product online

If you live in Australia please visit: [www.spectrumbrands.com.au/warranty](http://www.spectrumbrands.com.au/warranty)

If you live in New Zealand Please visit: [www.spectrumbrands.co.nz/warranty](http://www.spectrumbrands.co.nz/warranty)

Registration of your warranty is not compulsory, it gives us a record of your purchase AND entitles you to receive these benefits: Product information; Hints and tips; Recipes and news; Information on special price offers and promotions.

**Any questions?** Please contact Customer Service for advice.

Congratulations on the purchase of your new George Foreman Slow Cooker. Each unit is manufactured to ensure safety and reliability. Before using the Slow Cooker for the first time, please read this instruction booklet carefully and keep it for future reference. Pass it on if you pass on the Slow Cooker.

When using this appliance, basic safety precautions should always be followed.

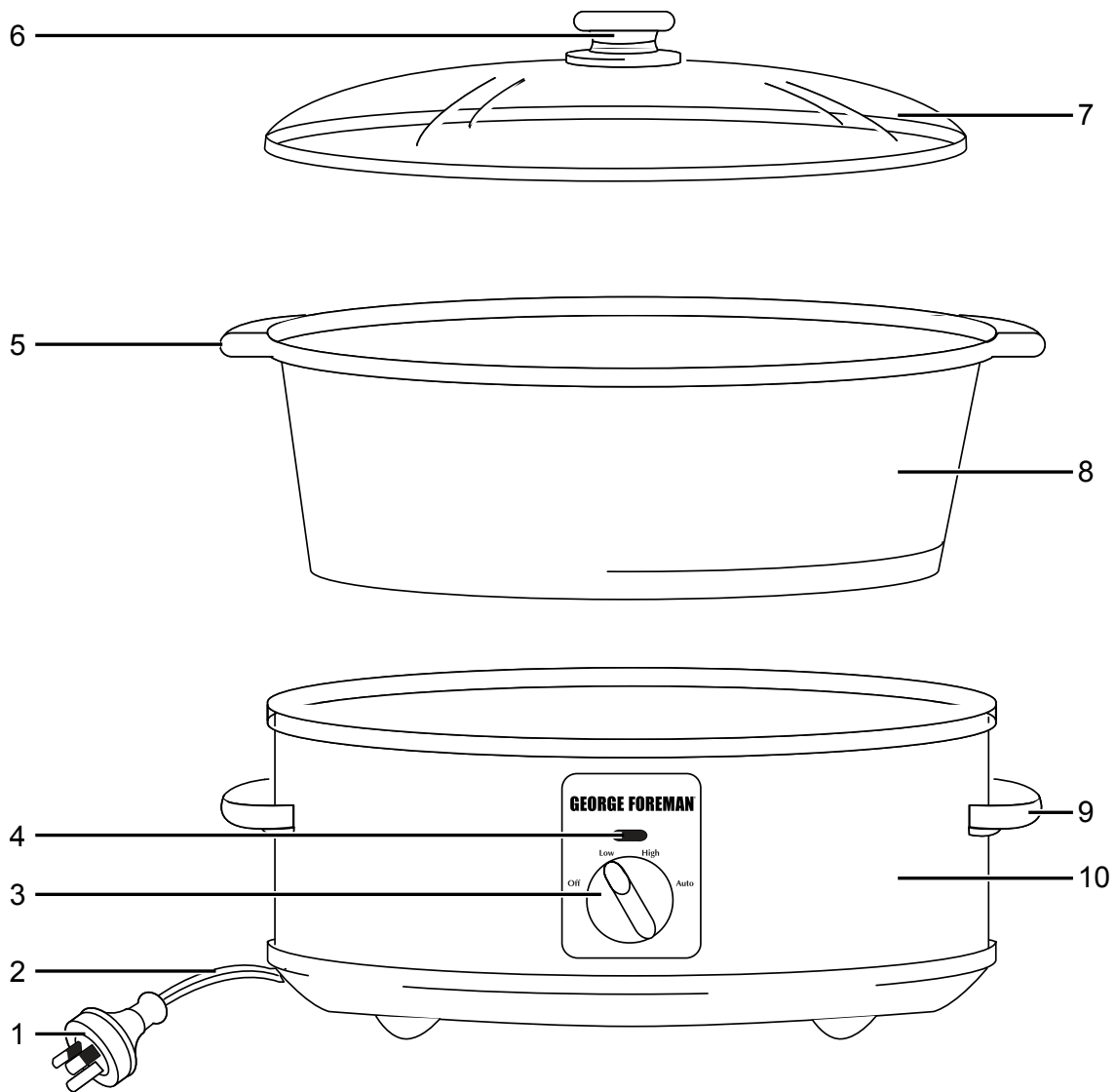

- |                                   |                                |
|-----------------------------------|--------------------------------|
| 1. Power plug                     | 6. Knob                        |
| 2. Power supply cord              | 7. Tempered glass lid assembly |
| 3. OFF/LOW/HIGH/AUTO Control Dial | 8. Ceramic bowl                |
| 4. Power indicator light          | 9. Base handles                |
| 5. Liner handles                  | 10. Stainless steel base unit  |

## The switch

The slow cooker is controlled by a 4-position switch:

- Off** The slow cooker is switched off and the power light is off.
- Low** Cooks at low power. Use this setting only after preheating the slow cooker on *High* for at least 20 minutes.
- High** Cooks at maximum power. Take care that the food does not dry out. If additional liquid is required, it should be preheated before adding to avoid possible cracking of the ceramic bowl. Cool liquids can be safely added in small amounts to the middle of the food, away from the sides of the ceramic bowl.
- Auto** When set on *Auto*, the slow cooker begins cooking on *High* until it reaches temperature. Then a thermostat switches the slow cooker automatically to *Low*, and remains on *Low* for the remaining duration of cooking time, until switched *Off*.

*NOTE: Auto setting does not switch the slow cooker off at any given time. You must turn the control dial to Off to stop cooking.*

## The benefits of slow cooking

- Health - The gentle cooking action reduces damage to vitamins and retains more of the nutrients and flavours. Also, cooking in a slow cooker does not require any added oil or fats.
- Economy - Long slow cooking can tenderise the cheaper, tougher cuts of meat and uses significantly less power than an oven or the small ring on the average cook top.
- Convenience - Prepare the ingredients the night before, put them in the slow cooker in the morning and have a delicious meal waiting for you when you get home.

## Before first use

- All parts of the Slow Cooker need to be thoroughly cleaned before being used for the first time (see 'Care and Maintenance').

## Preparation

- Some of the recipes call for meat to be browned and/or vegetables to be sautéed. Do this in a pan – not in the ceramic bowl. Do not use the ceramic bowl for cooking anywhere other than inside the slow cooker.
- Thaw frozen food completely before adding to the ceramic bowl.
- Do not cook on the low setting without first preheating the ceramic bowl in the slow cooker on High, for at least 20 minutes.
- Soak dried peas and beans for 8 hours (or overnight) before cooking, to soften them.  
**WARNING: Dried beans (e.g. red kidney beans) must be boiled for at least 10 minutes before being added to the slow cooker. They are poisonous if eaten raw or undercooked.**
- Lentils do not need soaking overnight.
- Store ingredients prepared beforehand (e.g. the night before) in a refrigerator. Do not put the slow cooker or the ceramic bowl in the refrigerator.
- Root vegetables (potatoes, carrots, onions etc) take much longer to cook than meat. Cut them into 5mm slices, sticks or dice. If possible, sauté gently for 2-3 minutes before adding to the ceramic bowl.
- Dried vegetables must be immersed in the cooking liquid.
- When cooking with rice, use at least 150ml of cooking liquid for each 100g of rice.
- Pasta is not suitable for slow cooking – it will become too soft. If your recipe requires pasta, it should be stirred in 30-40 minutes before the end of the cooking time.

## General use

- Decide when you want to eat and when you want to start cooking.
- Find a recipe that suits your timings. If you want to eat at 6pm and you need to start cooking at 8am, find a recipe that takes about 10 hours.
- Prepare the food as described in the recipe.

*TIP: Cut food into similar sized pieces to ensure food is evenly cooked.*

- Sit the slow cooker on a stable, level, heat-resistant surface and out of reach of children.
- Connect to the wall power outlet and switch the outlet on.
- Turn the switch on the slow cooker to High setting and allow to preheat for 20 minutes.
- Remove the lid and place the food in the ceramic bowl.
- Replace the lid.
- Turn the switch on the slow cooker to the required setting for cooking (Low, High or Auto).

*NOTE: A recipe that takes 10 hours would only ever be cooked using Low setting.*

- At the end of the cooking time, turn the switch to Off.
- Using oven gloves remove the lid from the slow cooker and set it on a heat proof surface.
- Serve the food.

*TIP: Cleaning can be made much easier if you remove all the cooked food from the ceramic bowl, then fill it with warm water (see 'Care and Maintenance').*

## Gravy / sauce

Slow cooking retains more of the juices than normal cooking. This tends to increase the volume of cooking liquid and thin the sauce or gravy. To allow for this, sauces should initially be thicker than normal. Anything to be sautéed could be tossed in seasoned flour beforehand, to thicken the gravy/sauce.

## Soup

If homemade soup appeals to you, then try some in your slow cooker. Tasty, homemade soups can be left simmering all day or overnight. Soup benefits from long cooking, so there is no need to worry if it is left for a few hours longer than intended. Flavours develop and infuse slowly and gently.

Tips for making soup in your slow cooker:

- Trim and cut up the meat and/or vegetables to similar sized portions to ensure even cooking.
- Sear food lightly in a large pan with a little cooking oil for a richer flavour.
- For a thicker soup, stir in flour or cornflour, and then gradually add stock.
- Do not add milk until the final half hour of cooking.
- Cream or egg yolk may be added just before serving.

## Recipes

There are a few recipes in this book to get you started, and there are also a number of excellent slow cooker recipes available at:

*[www.foodandhomeliving.com.au](http://www.foodandhomeliving.com.au) OR [www.foodandhomeliving.co.nz](http://www.foodandhomeliving.co.nz)*

Use them initially to familiarise yourself with the capabilities of your slow cooker. Then using them as a guide, vary the ingredients, vary the quantities and taste the results. Keep notes, write down what changes you make, and you will quickly build up a range of recipes which suit your taste. Keep notes of the not so successful ones as well, so that you know what not to do next time.

To adapt your own recipes for the slow cooker, we suggest you find a recipe which uses similar ingredients and use that as a guide for timing and liquid quantity, along with the food preparation guidelines given earlier. Be careful with quantities – once all the initial ingredients are put in the ceramic bowl, it shouldn't be more than  $\frac{3}{4}$  full, to allow for expansion.



## Care and maintenance

- Before doing anything else, unplug the slow cooker from the wall socket.
- Using oven gloves remove the lid and ceramic bowl and place them on a heatproof surface.
- Even if you do not intend to wash up right away, fill the ceramic bowl with warm water, otherwise the residual heat may bake any food debris on the ceramic bowl, making its eventual removal more difficult.
- Do not soak the exterior of the ceramic bowl in water. The base is porous and will soak up water which may cause it to crack when heated. Wash the lid and ceramic bowl in hot soapy water using a cloth or sponge, then rinse and dry thoroughly. Do not use a scouring pad. The ceramic bowl may be washed in the dishwasher.
- All other surfaces, internal and external, should be wiped with a damp cloth. You may use a little mild household detergent (washing up liquid) if necessary. These surfaces should be dry before re-using the slow cooker or storing it away.
- After some time in use, the glaze on the ceramic bowl may develop 'crazing', a network of small cracks. This marking is superficial and should not be a cause for concern.
- Do not immerse the body of the slow cooker in water or any other liquid.
- Do not use harsh or abrasive cleaners.
- Only the ceramic bowl is dishwasher safe. Do not put any other part of the slow cooker into the dishwasher.

# Important Safeguards

When using electrical appliances, basic safety precautions should always be followed.

1. To protect against electrical hazards, do not immerse the slow cooker in water or any liquid.
2. Do not use it in a bathroom or near any source of water. 
3. Do not use outdoors.
4. This appliance is not intended for use by persons (including children) with reduced physical, sensory or mental capabilities, or lack of experience and knowledge, unless they have been given supervision or instruction concerning use of the appliance by a person responsible for their safety.
5. This appliance is NOT a toy. Children should be supervised to ensure they do NOT play with this appliance.
6. Always follow the instructions when using this appliance.
7. Do not touch hot surfaces (including the outside of the slow cooker). Use oven gloves, and touch only the handles and the lid knob.
8. Keep clear of steam escaping around the lid area.
9. Do not touch any internal surfaces until the slow cooker has fully cooled down.
10. Do not use the slow cooker to re-heat food that has already been cooked.
11. Dried beans (e.g. red kidney beans) must be boiled for at least 10 minutes before being added to the slow cooker. They are poisonous if eaten raw or undercooked.
12. Sit the slow cooker on a stable, level, heat-resistant surface and out of reach of children.
13. Route the power cord so it does not overhang, and cannot be caught accidentally.
14. Unplug the slow cooker when not in use, before moving and before cleaning. Let it cool down fully before cleaning and storing away.
15. Do not try to cook in the slow cooker without using the ceramic bowl.
16. Leave a clear space of at least 75mm (3 inches) around the slow cooker when in use.
17. Do not cover the slow cooker or put anything on top of it while in use.
18. Do not use the slow cooker near or below curtains or other combustible materials.
19. Keep the power cord, the slow cooker, and the ceramic bowl away from hotplates, cook-tops and burners.
20. Do not put a hot ceramic bowl on a cold surface or in cold water as it may crack.
21. Do not put cold water into a hot ceramic bowl or hot water into a cold ceramic bowl as it may crack.
22. Do not use the ceramic bowl with any appliance (cook-top, stove, oven, microwave oven, etc) other than the slow cooker.
23. Do not use accessories or attachments other than those supplied as specifically for use with the slow cooker.
24. Do not use the slow cooker for any purpose other than that described in these instructions.
25. Do not connect this slow cooker to an external timer or remote control system.
26. Do not operate this appliance with a damaged cord/plug, or after the appliance has malfunctioned, or been dropped or damaged in any manner. Contact customer service for examination, adjustment, repair or replacement.
27. There are no user serviceable parts. If the power cord is damaged, it must be replaced by the manufacturer, or similarly qualified persons in order to avoid a hazard.
28. For added safety, electrical appliances should be connected to a power outlet that is protected by a residual current device (RCD), also often referred to as a 'Safety Switch'. Your switchboard may already incorporate an RCD. If unsure, call an electrician for verification and fitting if necessary.

SAVE THESE INSTRUCTIONS  
THIS APPLIANCE IS FOR HOUSEHOLD USE ONLY

# SELF SAUCING CHOCOLATE PUDDING

Serves 6

1. Preheat slow cooker for 20 minutes on High.
2. Grease the slow cooker bowl.
3. In a separate bowl, combine butter, vanilla extract, caster sugar, flour, cocoa powder and egg. Pour evenly across base of slow cooker bowl.
4. Sift brown sugar and extra cocoa powder over mixture.
5. Using a spoon, gently and evenly pour the boiling water over the mixture.
6. Cook on High for 2 ½ hours, or until centre is firm.
7. Serve with sifted icing sugar, and cream

## INGREDIENTS

1 cup caster sugar  
1 ½ self raising flour, sifted  
1 egg, lightly beaten  
1 cup, light brown sugar  
¾ cup milk  
1 tsp vanilla extract  
2 tbspcocoa powder  
2 tbspcocoa powder, extra  
2 ½ cups boiling water  
icing sugar, to serve  
Ice-cream / cream, to serve  
90g butter, melted and cooled

# CHICKEN CACCIATORE

Serves 4

## INGREDIENTS

1. In a large frypan over medium-high heat, brown the chicken, onion, and garlic in the olive oil.
2. Combine the sautéed chicken, onion and garlic with all the remaining ingredients, except the parsley, in the slow cooker ceramic bowl.
3. Place the lid on the bowl and cook for 3-4 hours on High or 7-8 hours on Low.
4. Season with salt and black pepper to taste and stir in the parsley before serving.

2 tsp olive oil  
1 kg chicken thigh fillets  
1 kg chicken drumsticks  
1 large onion, chopped  
2 cloves garlic, sliced  
very thin  
400g white mushrooms,  
sliced thin  
1/3 cup dry white wine or  
chicken stock  
2 cups canned crushed  
tomatoes  
1 tsp salt  
1/4 tsp ground black  
pepper  
1 tbsp minced parsley  
2 carrots peeled and  
chopped  
1 cup pitted kalamata  
olives  
2 celery sticks, chopped

# ROSEMARY & GARLIC ROASTED LEG OF LAMB

## INGREDIENTS

4 large all-purpose potatoes, peeled, cut into 1/4-inch thick slices  
2kg trimmed, boneless leg of lamb, tied  
1 tsp salt  
1/2 tsp coarsely ground black pepper  
6 cloves garlic, peeled and crushed  
4 sprigs fresh rosemary, chopped  
2 tbsp olive oil  
1/2 cup vegetable stock

Serves 6

1. Preheat the slow cooker for 20 minutes on High.
2. Layer potatoes in the bottom of the slow cooker ceramic bowl.
3. In a small bowl, mash the salt, pepper, garlic, and rosemary together with a fork to form a paste. Rub all over the lamb.
4. Heat the olive oil in a large frypan over a high heat and brown lamb on all sides. Put browned roast in the ceramic bowl on top of the potatoes.
5. Pour the stock in the frypan and bring to boil. Pour over the meat.
6. Place the lid on the slow cooker and cook for 4-5 hours on High or 9-10 hours on Low.

# BURGUNDY LAMB SHANKS

## INGREDIENTS

Serves 4

1. Season shanks with salt, pepper, lemon zest and oregano. Place in the slow cooker and sprinkle with garlic and parsley.
2. In a heavy-based frying pan, sauté carrot and onion in oil and transfer to slow cooker. Pour wine into frying pan and add stock cube. Deglaze frying pan and stir juices into slow cooker.
3. Cover and cook on Low for 8 hours. If you wish to have a thicker sauce, drain cooking liquid into a saucepan and boil to reduce and thicken slightly.

2kg lamb shanks  
Salt & Pepper, to taste  
Grated zest of ½ lemon  
½ tsp dried oregano  
2 cloves garlic, minced  
¼ cup fresh parsley, chopped  
1 carrot, peeled and chopped  
1 onion, chopped  
1 tsp olive oil  
1 cup dry red wine  
1 beef stock cube, crumbled

# STUFFED CAPSICUMS

## INGREDIENTS

6 large capsicums, tops  
cut off, cored and  
seeded  
500g lean, minced beef  
1 ½ cups cooked rice  
2 large eggs, lightly  
beaten  
½ cup grated cheese  
2 tbsps parsley, chopped  
½ tsp salt  
½ tsp black pepper  
800g canned chopped  
tomatoes  
½ tsp garlic powder

Serves 6

1. Preheat the slow cooker on HIGH for 20 minutes.
2. Combine the beef, cooked rice, egg, cheese, parsley, salt and pepper in a large mixing bowl.
3. Cut a very small hole in the bottom of each capsicum. Spoon the meat mixture into the capsicum; do not pack down.
4. Stand stuffed peppers upright in the slow cooker ceramic bowl.
5. Combine the tomatoes, garlic powder in a large mixing bowl. Spoon some of the sauce over each pepper. Pour the rest into the ceramic bowl.
6. Place the lid on the bowl and cook for 2-3 hours on HIGH or 5-6 hours on LOW.

Recipes are to be used in conjunction with the Slow Cooker by George Foreman. All rights reserved. No part of this publication may be reproduced, stored in a retrieval system or transmitted in any form or by any means, electronic, mechanical, photocopying, recording or otherwise, without prior permission of the copyright owner.

© Registered Trade Mark of Spectrum Brands, Inc., or one of its subsidiaries.  
©2011 Spectrum Brands, Inc.

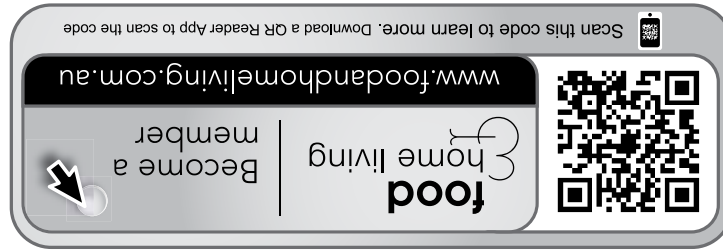

FOR MORE RECIPES:



RECIPES



HEALTHY COOKING  
**GEORGE FOREMAN**<sup>®</sup>