

This Owner's Manual is provided and hosted by [Appliance Factory Parts](#).

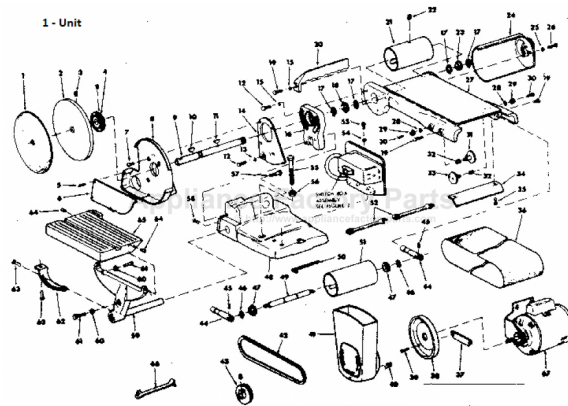

Craftsman 113225900 Owner's Manual

[Shop genuine replacement parts for Craftsman
113225900](#)



[Find Your Craftsman Other Parts - Select From 3 Models](#)

----- Manual continues below -----

Save This Manual
For Future Reference

SEARS

*owners
manual*

**MODEL NO.
113.225900**

BELT AND DISC
SANDER ONLY

**MODEL NO.
113.225931**

BELT AND DISC
SANDER/WITH
LEGS AND MOTOR

Serial
Number _____

Model and serial
number may be found
at the right-hand side
of the base.

You should record both
model and serial number
in a safe place for
future use.

CAUTION:

Read **SAFETY**
INSTRUCTIONS
carefully

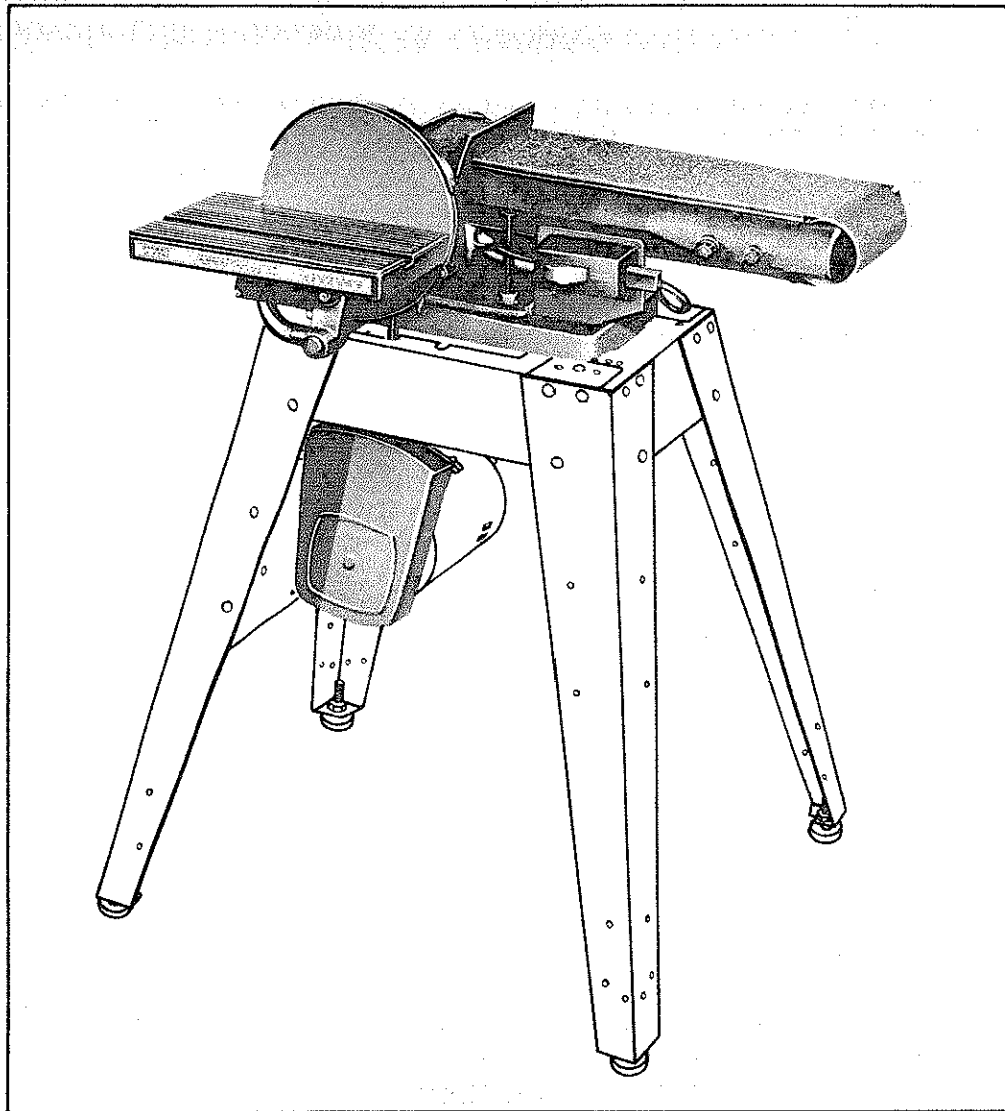

CRAFTSMAN

BELT AND DISC SANDER

- *assembly*
- *operating*
- *repair parts*

Sold by SEARS, ROEBUCK AND CO., Chicago, IL. 60684 U.S.A.

FULL ONE YEAR WARRANTY ON CRAFTSMAN BELT AND DISC SANDER

If within one year from the date of purchase, this Craftsman Belt and Disc Sander fails due to a defect in material or workmanship, Sears will repair it, free of charge.

WARRANTY SERVICE IS AVAILABLE BY SIMPLY CONTACTING THE NEAREST SEARS STORE OR SERVICE CENTER THROUGHOUT THE UNITED STATES.

This warranty gives you specific legal rights, and you may also have other rights which vary from state to state.

SEARS, ROEBUCK AND CO., Dept. 698/731A, Sears Tower, Chicago, IL 60684

general safety instructions for power tools

1. KNOW YOUR POWER TOOL

Read and understand the owner's manual and labels affixed to the tool. Learn its application and limitations as well as the specific potential hazards peculiar to this tool.

2. GROUND ALL TOOLS

This tool is equipped with an approved 3-conductor cord and a 3-prong grounding type plug to fit the proper grounding type receptacle. The green conductor in the cord is the grounding wire. Never connect the green wire to a live terminal.

3. KEEP GUARDS IN PLACE

— in working order, and in proper adjustment and alignment.

4. REMOVE ADJUSTING KEYS AND WRENCHES

Form habit of checking to see that keys and adjusting wrenches are removed from tool before turning it on.

5. KEEP WORK AREA CLEAN

Cluttered areas and benches invite accidents. Floor must not be slippery due to wax or sawdust.

6. AVOID DANGEROUS ENVIRONMENT

Don't use power tools in damp or wet locations or expose them to rain. Keep work area well lighted. Provide adequate surrounding work space.

7. KEEP CHILDREN AWAY

All visitors should be kept a safe distance from work area.

8. MAKE WORKSHOP CHILD-PROOF

with padlocks, master switches, or by removing starter keys.

9. DON'T FORCE TOOL

It will do the job better and safer at the rate for which it was designed.

10. USE RIGHT TOOL

Don't force tool or attachment to do a job it was not designed for.

11. WEAR PROPER APPAREL

Do not wear loose clothing, gloves, neckties or jewelry (rings, wristwatches) to get caught in moving parts. NONSLIP footwear is recommended. Wear protective hair covering to contain long hair. Roll long sleeves above the elbow.

12. USE SAFETY GOGGLES (Head Protection)

Wear safety goggles (must comply with ANSI Z87.1) at all times. Everyday eyeglasses only have impact resistant lenses, they are NOT safety glasses. Also, use face or dust

mask if cutting operation is dusty, and ear protectors (plugs or muffs) during extended periods of operation.

13. SECURE WORK

Use clamps or a vise to hold work when practical. It's safer than using your hand, frees both hands to operate tool.

14. DON'T OVERREACH

Keep proper footing and balance at all times.

15. MAINTAIN TOOLS WITH CARE

Keep tools sharp and clean for best and safest performance. Follow instructions for lubricating and changing accessories.

16. DISCONNECT TOOLS

before servicing; when changing accessories such as blades, bits, cutters, etc.

17. AVOID ACCIDENTAL STARTING

Make sure switch is in "OFF" position before plugging in.

18. USE RECOMMENDED ACCESSORIES

Consult the owner's manual for recommended accessories. Follow the instructions that accompany the accessories. The use of improper accessories may cause hazards.

19. NEVER STAND ON TOOL

Serious injury could occur if the tool is tipped or if the cutting tool is accidentally contacted.

Do not store materials above or near the tool such that it is necessary to stand on the tool to reach them.

20. CHECK DAMAGED PARTS

Before further use of the tool, a guard or other part that is damaged should be carefully checked to ensure that it will operate properly and perform its intended function. Check for alignment of moving parts, binding of moving parts, breakage of parts, mounting, and any other conditions that may affect its operation. A guard or other part that is damaged should be properly repaired or replaced.

21. DIRECTION OF FEED

Feed work into a blade or cutter against the direction of rotation of the blade or cutter only.

22. NEVER LEAVE TOOL RUNNING UNATTENDED

Turn power off. Don't leave tool until it comes to a complete stop.

safety instructions for belt and disc sander

Safety is a combination of common sense, staying alert and knowing how your belt and disc sander works. Read this manual to understand this sander.

BEFORE USING THE SANDER:

WARNING: To avoid mistakes that could cause serious, permanent injury, do not plug the sander in until the following steps are completed.

- Assembly. (See pages 7 - 16.)
- Learn the use and function of the ON-OFF switch, backstop lock screw, belt adjusting screws, belt locking screws, work table and work table tilt lock screw. (See pages 16 - 18.)
- Review and understanding of all safety instructions and operating procedures in this manual.
- Review of the maintenance methods for this sander. (See page 22.)

Read the following DANGER label found on the front of the sander:

DANGER FOR YOUR OWN SAFETY:	1 READ AND UNDERSTAND OWNERS MANUAL BEFORE OPERATING MACHINE	4 AVOID "KICKBACK" (WORKPIECE THROWN AT YOU) - DO NOT USE RIGHT HALF OF DISC
	2 WEAR SAFETY GOGGLES AND DUST MASK	5 ALWAYS SUPPORT WORKPIECE WITH "BACK STOP" OR "WORKTABLE"
	3 MAINTAIN 1/8 INCH MAXIMUM CLEARANCE BETWEEN TABLE AND SANDING BELT OR DISC	6 DO NOT ATTACH HOME IN SHOP VAC TO DISC HOUSING WHEN SANDING IRON OR STEEL

WHEN INSTALLING OR MOVING THE SANDER.

AVOID DANGEROUS ENVIRONMENT. Use the sander in a dry, indoor place protected from rain. Keep work area well lighted.

Place the sander so neither the user or bystanders are forced to stand in line with the abrasive belt or disc.

To avoid injury from unexpected sander movement:

- Put the sander on a firm level surface where there is plenty of room for handling and properly supporting the workpiece.
- Support the sander so it does not rock.
- Bolt the sander to the floor or work surface if it tends to slip, walk, or slide during normal use.

To avoid injury or death from electrical shock:

- **GROUND THE SANDER.** This sander has an approved 3-conductor cord and a 3-prong grounding type plug. Use only 3-wire, grounded outlets rated 120 volts, 15 amperes (amps). The green conductor in the cord is the grounding wire. To avoid electrocution, NEVER connect the green wire to a live terminal.
- Make sure your fingers do not touch the plug's metal prongs when plugging or unplugging the sander.

To avoid back injury, get help or use recommended casters when you need to move the sander. Always get help if you need to lift the sander.

NEVER STAND ON TOOL. Serious injury could occur if the tool tips or you accidentally hit the cutting tool. Do not store anything above or near the tool where anyone might stand on the tool to reach them.

BEFORE EACH USE:

Inspect your sander.

DISCONNECT THE SANDER. To avoid injury from accidental starting, unplug the sander, turn the switch off and remove the switch key before changing the setup, sanding disc or belt or adjusting anything.

CHECK DAMAGED PARTS. Check for:

- alignment of moving parts,
- binding of moving parts,
- broken parts,
- stable mounting, and
- any other conditions that may affect the way the sander works.

WARNING: The 2-1/2" machine pulley and the 2" motor pulley furnished will run the disc at about 2700 RPM and the belt at about 2100 FPM (Feet Per Minute) when used with a 3450 RPM motor. To avoid throwing of work or broken sander fragments, never substitute or interchange these pulleys to increase this speed.

If any part is missing, bent, or broken in any way, or any electrical parts don't work properly, turn the sander off and unplug the sander. REPLACE damaged, missing, or failed parts before using the sander again.

MAINTAIN TOOLS WITH CARE. Keep the sander clean for best and safest performance. Follow instructions for lubricating.

REMOVE ADJUSTING KEYS AND WRENCHES from tool before turning it on.

To avoid injury from jams, slips or thrown pieces:

- **USE ONLY RECOMMENDED ACCESSORIES.** (See page 22.) Consult this Owner's manual for recommended accessories. Follow the instructions that come with the accessories. The use of improper accessories may cause risk of injury to persons.
- Adjust table to clear the sanding surface by no more than 1/16 of an inch.
- Make sure all clamps and locks are tight and no parts have excessive play.
- **KEEP WORK AREA CLEAN.** Cluttered areas and benches invite accidents. Floor must not be slippery.

To avoid burns or other fire damage, never use the sander near flammable liquids, vapors or gases.

Plan ahead to protect your eyes, hands, face, ears.

KNOW YOUR SANDER. Read and understand the owner's manual and labels affixed to the tool. Learn its application and limitations as well as the specific potential hazards peculiar to this tool.

To avoid injury from accidental contact with moving parts, don't do layout, assembly, or setup work on the sander while any parts are moving.

AVOID ACCIDENTAL STARTING. Make sure switch is "OFF" before plugging sander into a power outlet.

safety instructions for belt and disc sander

Plan your work.

USE THE RIGHT TOOL. Don't force tool or attachment to do a job it was not designed to do.

CAUTION: This machine is not designed for heavy deburring operations. When finishing metals, sparks or hot fragments could cause a fire. To avoid this, disconnect any dust collecting hose from the sander. Also, remove all traces of wood dust from inside dust traps in the sander.

Dress for safety.



Any power sander can throw foreign objects into the eyes. This can cause permanent eye damage. Wear safety goggles (not glasses) that comply with ANSI Z87.1. Everyday eyeglasses have only impact resistant lenses. They are not safety glasses. Safety goggles are available at Sears retail catalog stores. Glasses or goggles not in compliance with ANSI Z87.1 could seriously hurt you when they break.

- Do not wear loose clothing, gloves, neckties or jewelry (rings, wrist watches). They can get caught and draw you into moving parts.
- Wear nonslip footwear.
- Tie back long hair.
- Roll long sleeves above the elbow.
- Noise levels vary widely. To avoid possible hearing damage, wear ear plugs or muffs when using sander for hours at a time.
- Sanding operations are usually dusty. Wear a dust mask along with the safety goggles.

Inspect your workpiece.

Make sure there are no nails or foreign objects in the part of the workpiece to be sanded.

Plan your work to avoid THROWBACKS—when the workpiece catches on the sanding belt or disc and is torn from your hands.

- Make sure there's no debris between the workpiece and its supports.
- When sanding irregularly shaped workpieces, plan your work support so it will not slip and be pulled from your hands.
- Use extra caution with large, very small or awkward pieces:
- Never use this tool to finish pieces too small to hold by hand.

- Use extra supports (tables, saw horses, blocks, etc.) for any workpieces large enough to tip when not held down to the table top.
- NEVER use another person as a substitute for a table extension, or as additional support for a workpiece that is longer or wider than the basic sander table, or to help feed, support or pull the workpiece.
- When finishing on the Disc, always press the workpiece against the "Down" side of the disc. Sanding against the side coming up from under the table could damage the work by making it "chatter," or tear the work from your hands and throw it.
- Sand only one workpiece at a time.
- Clear everything except the workpiece and related support devices off the table before turning the sander on.

Plan the way you will hold the workpiece from start to finish.

Avoid awkward operations and hand positions where a sudden slip could cause fingers or hand to move into a sanding surface. Keep fingers away from where the belt goes into the dust trap.

DON'T OVERREACH. Keep good footing and balance.

Keep your face and body to one side, out of line with a possible throwback.

WHENEVER SANDER IS RUNNING.

WARNING: Don't let familiarity (gained from frequent use of your belt and disc sander) cause a careless mistake. A careless fraction of a second is enough to cause a severe injury. Before starting your cut, watch the sander while it runs. If it makes an unfamiliar noise or vibrates a lot, stop immediately. Turn the sander off. Unplug the sander. Do not restart until finding and correcting the problem.

Make sure the sanding disc turns counterclockwise before using the sander.

KEEP CHILDREN AWAY. Keep all visitors a safe distance from the sander. Make sure bystanders are clear of the sander and workpiece.

DON'T FORCE TOOL. It will do the job better and safer at its designated rate. Press the workpiece against the sanding material only hard enough to let it sand without bogging down or binding.

Before freeing any jammed material:

- Turn switch "OFF"
- Unplug the sander.
- Wait for all moving parts to stop.

To avoid throwback of the workpiece, use workpiece supports for all flat surface sanding.

BEFORE LEAVING THE SANDER:

Wait for all moving parts to stop.

Make workshop child-proof. Lock the shop. Disconnect master switches. Remove the yellow switch key. Store it away from children and others not qualified to use the tool.

electrical requirements

CONNECTING TO POWER SOURCE OUTLET

This machine must be grounded while in use to protect the operator from electric shock.

Plug power cord into a 120V properly grounded type outlet protected by a 15-amp. dual element time delay or Circuit-Saver fuse or circuit breaker.

If you are not sure that your outlet is properly grounded, have it checked by a qualified electrician.

WARNING: DO NOT PERMIT FINGERS TO TOUCH THE TERMINALS OF PLUGS WHEN INSTALLING OR REMOVING THE PLUG TO OR FROM THE OUTLET.

WARNING: IF NOT PROPERLY GROUNDED THIS POWER TOOL CAN INCUR THE POTENTIAL HAZARD OF ELECTRICAL SHOCK. PARTICULARLY WHEN USED IN DAMP LOCATIONS IN PROXIMITY TO PLUMBING. IF AN ELECTRICAL SHOCK OCCURS THERE IS THE POTENTIAL OF A SECONDARY HAZARD SUCH AS YOUR HANDS CONTACTING THE ABRASIVE BELT OR DISC.

If power cord is worn or cut, or damaged in any way, have it replaced immediately.

Your unit is wired for 120 volts and has a plug that looks like the one shown below.

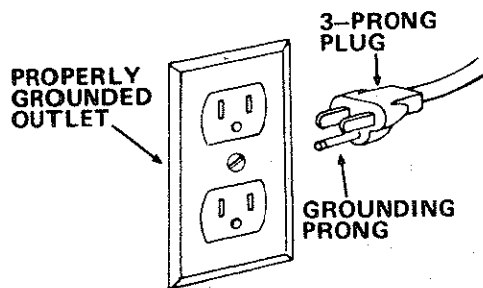

This power tool is equipped with a 3-conductor cord and grounding type plug, approved by Underwriters' Laboratories and the Canadian Standards Association. The ground conductor has a green jacket and is attached to the tool housing at one end and to the ground prong in the attachment plug at the other end.

This plug requires a mating 3-conductor grounded type outlet as shown.

If the outlet you are planning to use for this power tool is of the two prong type **DO NOT REMOVE OR ALTER THE GROUNDING PRONG IN ANY MANNER.** Use an adapter as shown and always connect the grounding lug to known ground.

It is recommended that you have a qualified electrician replace the TWO prong outlet with a properly grounded THREE prong outlet.

A temporary adapter as shown below is available for connecting plugs to 2-prong receptacles. The green grounding lug extending from the adapter must be connected to a permanent ground such as to a properly grounded outlet box.

A temporary adapter as illustrated is available for connecting plugs to 2-prong receptacles. The temporary adapter should be used only until a properly grounded outlet can be installed by a qualified electrician.

NOTE: The adapter illustrated is for use only if you already have a properly grounded 2-prong receptacle.

The use of any extension cord will cause some loss of power. To keep this to a minimum and to prevent overheating and motor burn-out, use the table below to determine the minimum wire size (A.W.G.) extension cord. Use only 3 wire extension cords which have 3-prong grounding type plugs and 3-pole receptacles which accept the tools plug.

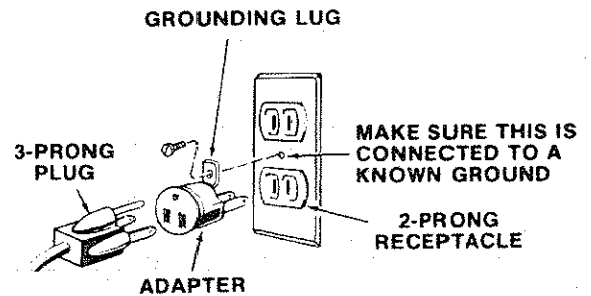

Extension Cord Length	Wire Size	A.W.G.
0-25 Ft.	16	
26-50 Ft.	14	
51-100 Ft.	12	

CHECK MOTOR ROTATION

Place the motor on your workbench or on the floor. Standing clear of the motor shaft, plug the motor cord into a properly grounded outlet. Notice the rotation of the shaft. As you look directly at the motor shaft it should be turning in the counterclockwise direction . If the motor shaft is turning counterclockwise, remove the plug from the power outlet and continue the assembly procedures. If the motor is turning clockwise, remove the plug from the power outlet and contact your Sears Store immediately.

CONTENTS

SAFETY INSTRUCTIONS FOR POWER TOOLS	2	Belt Locking Screws	17
ADDITIONAL SAFETY INSTRUCTIONS FOR BELT AND DISC SANDER	3	Work Table Tilt Lock Screw	17
ELECTRICAL REQUIREMENTS	5	Backstop Lock Screw	18
Check Motor Rotation	5	Belt Table Locking Bolts	18
UNPACKING AND CHECKING CONTENTS	6	Belt Table Stop	18
ASSEMBLY	7	BASIC OPERATION	19
Assembling Steel Legs	8	Surface Finishing on the Abrasive Belt	20
Mounting Belt and Disc Sander on Steel Leg Set	8	End Finishing on the Abrasive Belt	20
Installing Sanding Disc and Dust Trap	9	Finishing Curved Edges on the Abrasive Belt	21
Installing Motor, V-Belt Tensioning and Tracking	11	Finishing Small End Surfaces and Curved Edges on Disc	21
On-Off Switch	12	MAINTENANCE	22
Installing Work Table	14	Motor Maintenance and Lubrication	22
Installing Abrasive Belt Tensioning and Tracking	14	LUBRICATION	22
Installing Belt Dust Trap	15	Recommended Accessories	22
Installing Backstop	16	TROUBLESHOOTING	23
GETTING TO KNOW YOUR SANDER	16	REPAIR PARTS	25
Belt Adjusting Screws	17	Motor Connections	29

unpacking and checking contents

Model 113.225900 Belt and Disc Sander is shipped complete in one carton but DOES NOT INCLUDE Steel Legs or Motor.

Model 113.225931 Belt and Disc Sander is shipped complete in one carton and INCLUDES Steel Legs and Motor.

Separate all parts from packing materials and check each item with illustration and "Table of Loose Parts." Make certain all items are accounted for, before discarding any packing material.

If any parts are missing, do not attempt to assemble the Belt and Disc Sander, plug in the power cord, or turn the switch on until the missing parts are obtained and installed correctly.

Using a 1/2" wrench, remove the plywood attached to the machine. Save the nuts and bolts and washers. You will need them for attaching the machine to the base.

TOOLS NEEDED

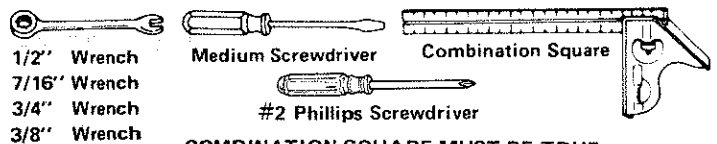

COMBINATION SQUARE MUST BE TRUE.

DRAW LIGHT LINE ON BOARD ALONG THIS EDGE

STRAIGHT EDGE OF BOARD 3/4" THICK THIS EDGE MUST BE PERFECTLY STRAIGHT

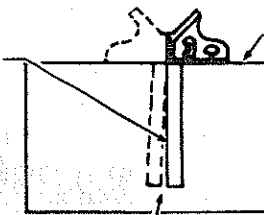

SHOULD BE NO GAP OR OVERLAP HERE WHEN SQUARE IS FLIPPED OVER IN DOTTED POSITION

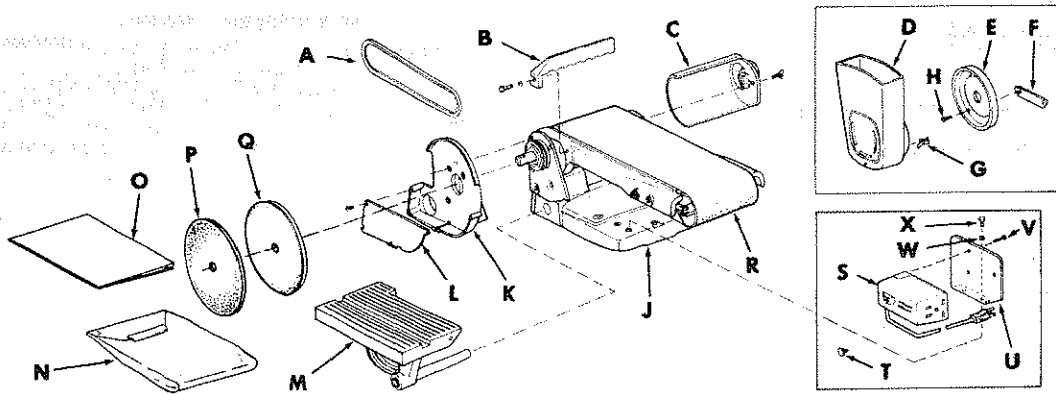

Item	Table of Loose Parts	Qty.
A	V-Belt, 1/2 x 41"	1
B	Backstop	1
C	Belt, Dust Trap	1
D	Motor Pulley Belt Guard	1
E	Belt Guard Support	1
F	Belt Guard Support Bracket	1
G	"S" Clip	3
H	Pan Head Screw, Type 23, 10-32 x 1/2	3
J	Base and Belt, Table (w/Sanding Belt)	1
K	Disc Dust Trap	1
L	Dust Trap Cover	1
M	Work Table	1
N	Bag (containing the following loose parts) (Part No. 68035)	
	Motor Pulley, 2 In. Dia.	1
	Wrench, 1/2"	2
	5/32 Setscrew Wrench	1
	Flat Head Machine Screw 10-32 x 1-3/4	4

Item	Table of Loose Parts	Qty.
	Pan Head Screw, Type 23 8-32 x 3/8	5
	Flat Washer, 21/64 x 7/8 x 1/8	1
	Hex, Head Machine Screw 5/16-18 x 1	1
	Screw, M Pan Hd. 10-32 x 9/16	1
	Lockwasher No. 10 Int. Tooth	1
	Hanger, Cable	1
O	Owner's Manual	1
P	9" Abrasive Disc	1
Q	Sanding Disc (w/Set Screw)	1
R	Belt, Sanding	1
-	Bag Assembly, Outlet (Part No. 68064) (Containing the following loose parts):	
S	Outlet, on/off Power	1
T	Switch Key	1
U	Bracket, Switch Mounting	1
V	Screw, Pan Hd. 8 x 3/8	3
W	Lockwasher, 1/4"	2
X	Screw; Pan Hd. Machine 1/4-20 x 1/2	2

assembly

The following parts are included with Model 113.225931 ONLY.

Item No.	Qty.
*Loose Parts Bag Part #68062 Containing Following Items:	
*A Nut, Hex Head 1/2-13	8
*A Nut Hex 1/4-20	32
*B Screw Truss Hd. 1/4-20 x 5/8	32
*C Lockwasher, 1/4 External	32
*D Foot, Leveling	4
E Motor	1
F Leg	4
G Channel, Support	2
H Stiffener, Side	2
J Stiffener, End	2
K Support, Motor	1
P Bracket, Mounting	1

HARDWARE FOR MOUNTING TOOL & MOTOR

*L Screw, Hex Hd. 5/16-18 x 1-1/2	2
*C Lockwasher Ext. 5/16	6
*A Nut, Hex 5/16-18	6
*M Washer 11/32 ID	6
*N Bolt, Carriage 5/16-18 x 3/4	4

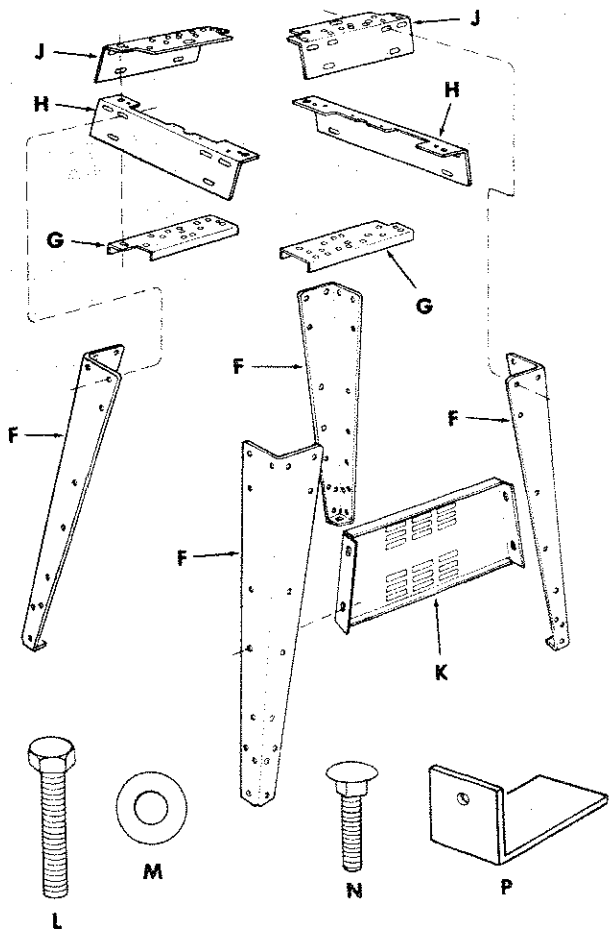
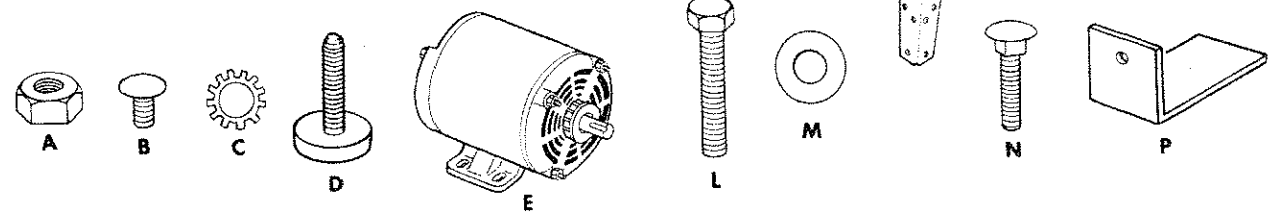

assembly

ASSEMBLING STEEL LEGS (MODEL 113.225931 ONLY)

1. Assemble the two (2) End Stiffeners and the two (2) Side Stiffeners using four (4) 1/4-20 Truss head screws. The End Stiffeners are placed on top of each Side Stiffener as shown. Insert screws through the 9/32 inch diameter holes and finger tighten 1/4-20 nuts.
2. Attach the four (4) legs to the side and End Stiffener using 1/4-20 screws, lockwashers and nuts as shown.
3. Remove the four (4) Truss head screws which were assembled in Paragraph No. One. Place the two (2) Support Channels as shown, in position, align holes in supports with holes in the Stiffeners, replace lockwashers and nuts. Tighten all nuts using 7/16" wrench.
4. Assemble the motor support to steel legs with 1/4-20 screws and nuts. Motor support can be mounted to either end of stand. Tighten nuts.
5. Install leveling feet as shown. To level Leg Set, loosen nut on inside of leg and turn nut on outside to raise or lower feet. Adjust all four levelers, if necessary, and then tighten nuts on inside of leg.

NOTE: These levelers are not intended for height adjustment.

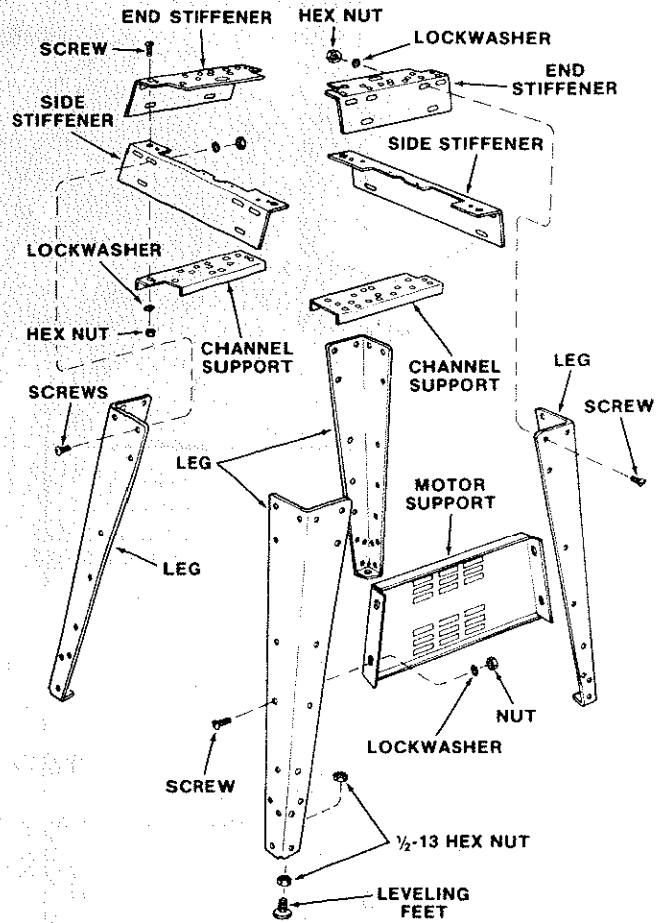

WHEN INSTALLING OR MOVING THE SANDER.

AVOID DANGEROUS ENVIRONMENT. Use the sander in a dry, indoor place protected from rain. Keep work area well lighted.

Place the sander so neither the user nor bystanders are forced to stand in line with the abrasive belt or disc.

To avoid injury from unexpected sander movement:

- Put the sander on a firm level surface where there is plenty of room for handling and properly supporting the workpiece.
- Support the sander so it does not rock.
- Bolt the sander to the floor or work surface if it tends to slip, walk, or slide during normal use.

To avoid back injury, get help or use recommended casters when you need to move the sander. Always get help if you need to lift the sander.

NEVER STAND ON TOOL. Serious injury could occur if the tool tips or you accidentally hit the cutting tool. Do not store anything above or near the tool where anyone might stand on the tool to reach them.

MOUNTING BELT AND DISC SANDER ON CRAFTSMAN STEEL LEG SET.

CATALOG NO. 9-22236

NOTE: For illustrative purposes, the Belt and Disc Sander is shown mounted on the Craftsman Catalog No. 9-22236 Steel Leg Set. This Leg Set is included with Model No. 113.225931.

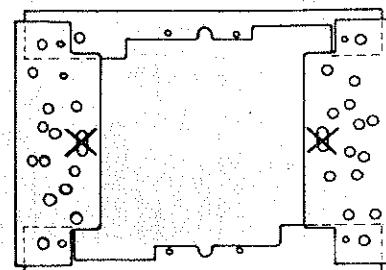
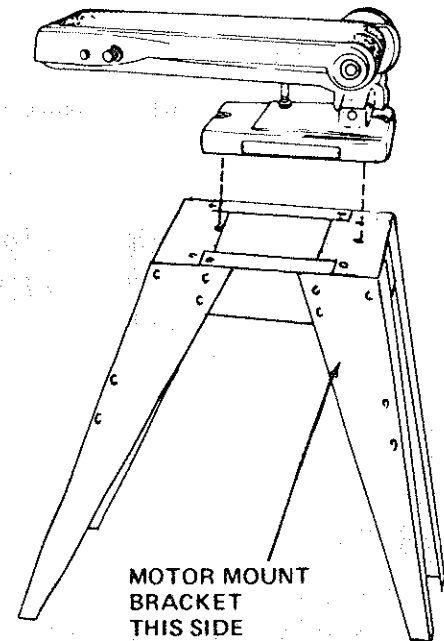

1. Place the Belt and Disc Sander on the Steel Legs, position as shown, and align the mounting holes in the feet of the Belt and Disc Sander with those in the END STIFFENERS (marked with an X in the illustration).

2. Mount to legs using two 5/16-18 x 2-1/2" hex head screws, flat washers, external lockwashers, and hex nuts.

NOTE: The abrasive belt is shipped detached. To install the belt on the machine:

1. Loosen both belt LOCKING screws, using the 1/2" wrench furnished with the machine.
2. Turn both of the abrasive belt ADJUSTING screws as shown until they stop. Retighten the two belt LOCKING screws so that the idler pulley does not come out.
3. Remove the piece of paper.
4. Remove the protective coating, that is applied at the factory, from the belt table. Use any ordinary household type grease and spot remover.

WARNING: Never use gasoline, naphtha, or similar highly volatile solvents.

NOTE: Do not apply wax to the belt table.

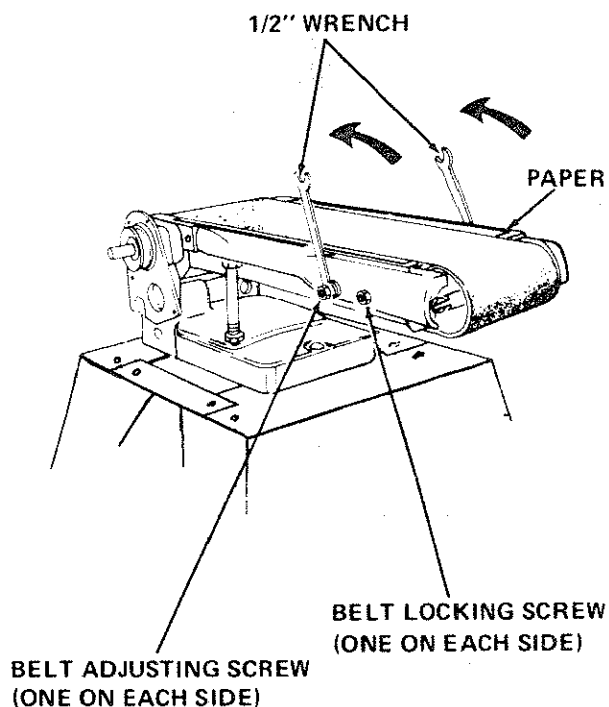

INSTALLING SANDING DISC AND DUST TRAP

1. Loosen the belt table locking bolts behind the mounting bracket using one of the 1/2" wrenches supplied with your machine.
2. Position belt table vertically and tighten only one of the bolts.
3. Place the V-Belt over the pulley.
4. Attach the switch assembly to the base using the two screws and washers packed with the switch.
5. Loosen the bolt that you tightened in step 2. Position the belt table horizontally, and tighten both bolts.

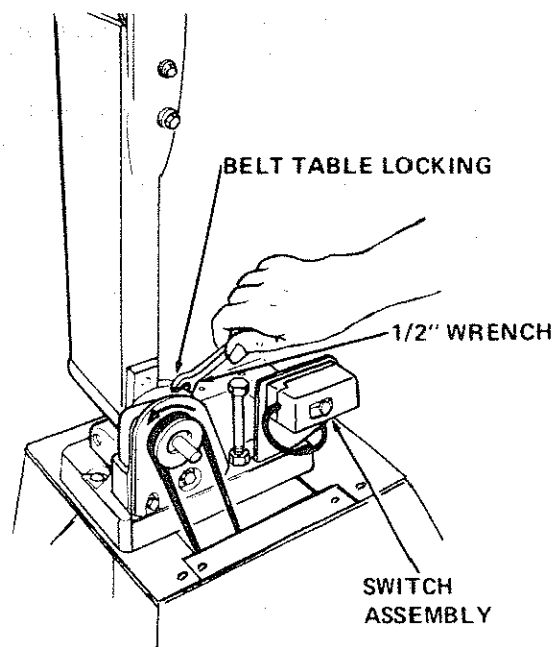

assembly

6. Find five 3/8" Pan Head Self-Treading screws from among the loose parts.

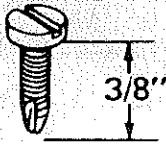

7. Place Disc Dust Trap on your workbench and screw in five Pan Head "Thread Cutting Screws," 3/8" long. Screw them in all the way.

NOTE: The holes in the Trap are not threaded but the screws are "Thread Cutting Screws" and will cut a thread as they are tightened.

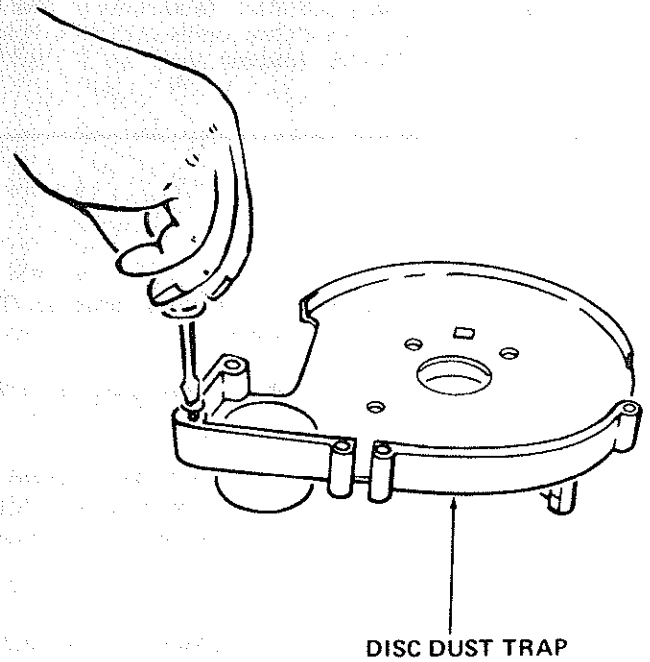

8. Find four Flat Head Machine Screws 1-3/4" long from among the loose parts

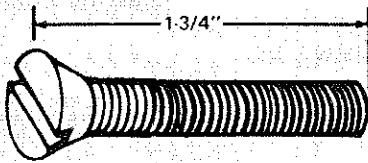

FLAT HEAD SCREWS
1 3/4" LONG

FLAT SPOT
ON SHAFT

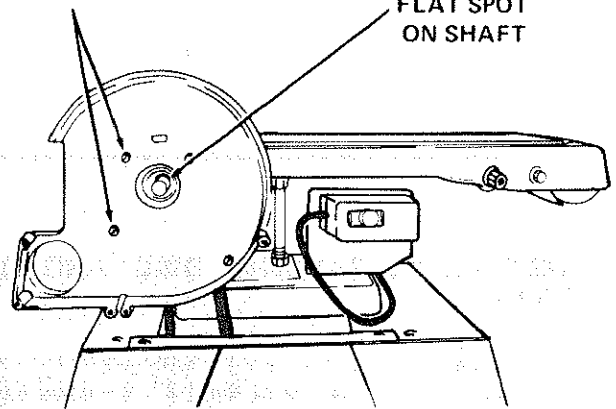

9. Attach the Disc Dust Trap with four flat head screws 1-3/4" long.

10. There is a flat spot on the shaft near the end. Rotate the shaft so that the flat spot is facing up.

11. Place the disc on the shaft so that the set screw is facing up. Position the disc so that it is approx. 1/16 inch outward from the edge of the dust trap.

12. Insert the long end of the 5/32" setscrew wrench through the hole in the disc housing and into the setscrew in the disc. Make sure setscrew is aligned with "Flat" on shaft.

NOTE: After several hours of operation, check for looseness of setscrew and retighten.

13. Make certain that the metal disc is free of oil and grease then peel the backing from the 9" abrasive disc and affix to the sanding disc.

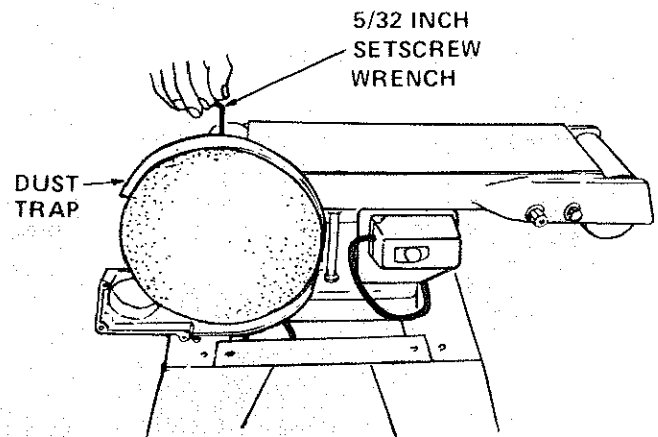

14. Remove the top right hand screw which you installed in step 6 and loosen the other three screws.
15. Install the Dust Trap cover and replace the top right hand screw. Tighten all five screws.

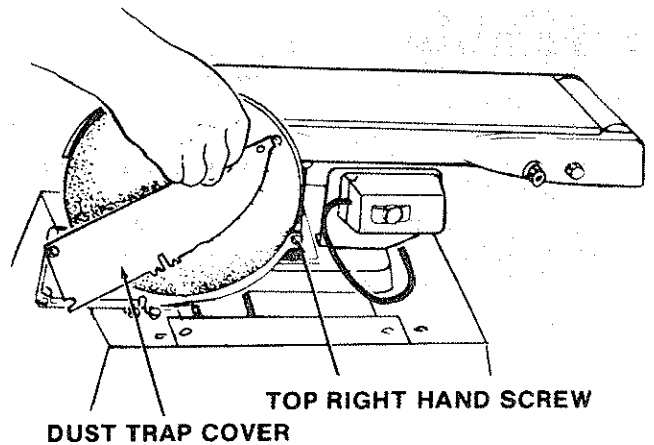

INSTALLING MOTOR, V-BELT, AND BELT GUARD

1. Locate the following parts:

QTY.	Description
1	Motor
1	"L" Bracket
1	Pulley (approx. 2" Dia.)
1	V-Belt
4	Carriage Bolt 5/16-18 x 3/4
4	Flat Washer 5/16 I.D.
4	Lockwasher 5/16 I.D.
4	Hex Nut 5/16-18
1	Guard Assembly including a guard support, guard support bracket, self-threading screws, and clips.

2. Place motor against the motor mounting bracket and insert bolts through holes in motor base and then through holes marked "X" in motor mounting bracket. **DO NOT TIGHTEN BOLTS AT THIS TIME.** The "L" bracket which holds the guard support must be slid between the motor base and the motor mounting bracket so motor must be loosely assembled to bracket at this time.

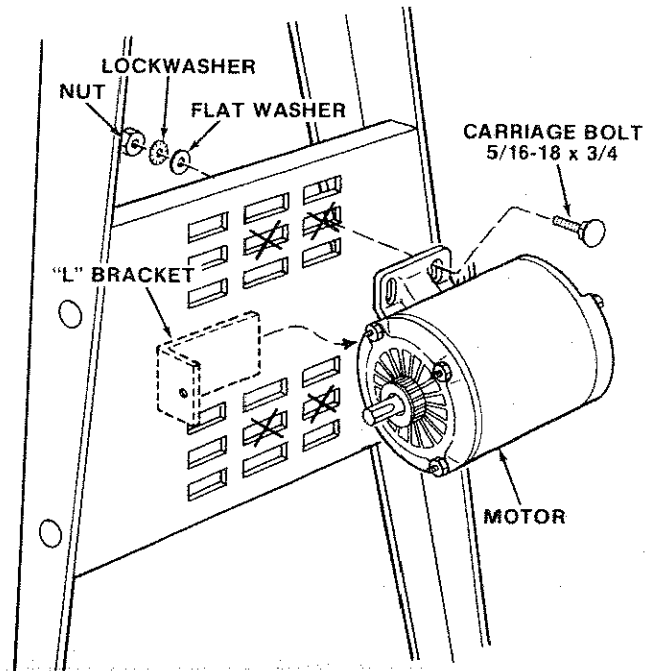

3. Slide long leg of "L" bracket between motor base and motor mounting bracket. Then sandwich the "L" bracket between the guard support bracket and the guard support and fasten together with self-threading screws as shown. Install clips onto belt guard support.
4. Install the 2" pulley onto the motor shaft flush with the end of the shaft and tighten the set screw in the pulley hub against the flat part of the motor shaft.

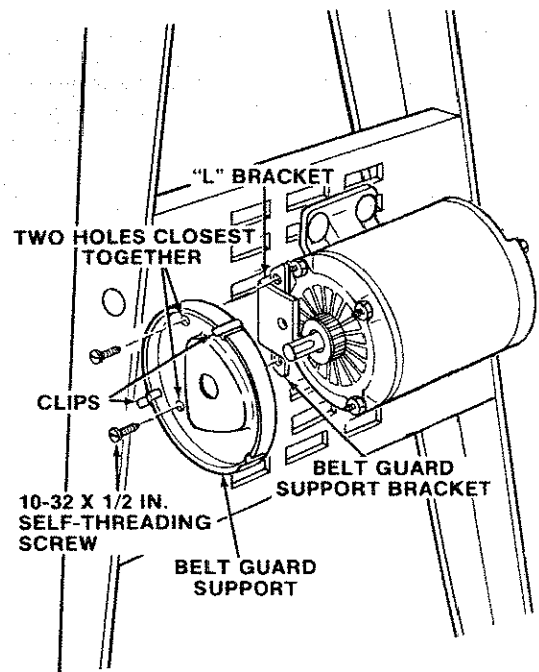

assembly

5. Place belt over machine pulley and insert the belt into the open end of the guard and out the round opening.
MAKE SURE BELT HAS NOT SLIPPED OFF OF MACHINE PULLEY FROM STEP 3, DISC AND DUST TRAP INSTALLATION.

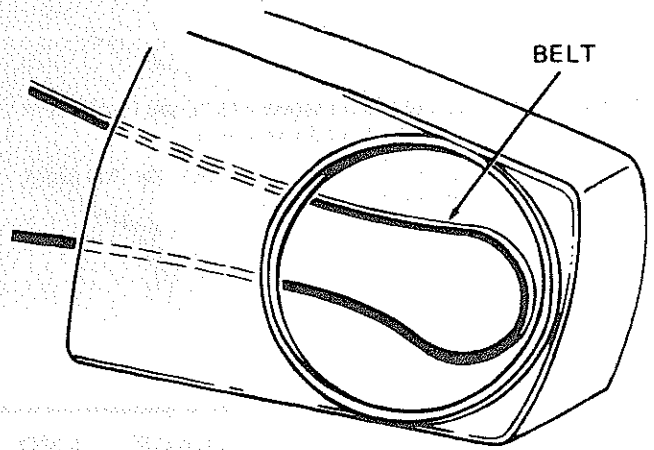

6. Place the belt onto the motor pulley by rotating the pulley.
7. Move the motor sideways so that the belt is in the center of the opening in the top of the base. Visually line up the pulleys and V-belt.
8. PUSH downward on motor to apply tension to belt and tighten motor bolt nuts.
9. Check guard support before tightening guard support screws. Guard support must be centered around motor shaft. Tighten screws.
10. Push guard into position on guard support.

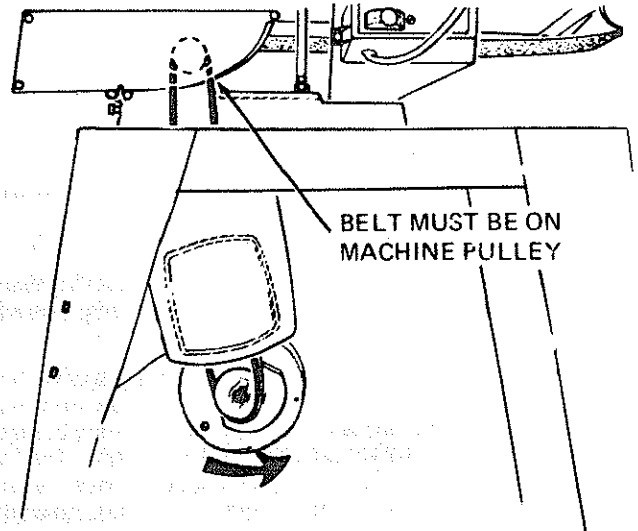

ON-OFF SWITCH

WARNING: DON'T CONNECT POWER CORD TO ELECTRICAL OUTLET IN YOUR SHOP UNTIL YOU ARE SURE MOTOR ROTATION IS CORRECT. SEE PAGE 5.

The On-Off Switch has a locking feature. THIS FEATURE IS INTENDED TO PREVENT UNAUTHORIZED AND POSSIBLE HAZARDOUS USE BY CHILDREN AND OTHERS.

1. Insert key into switch.

NOTE: Key is made of yellow plastic

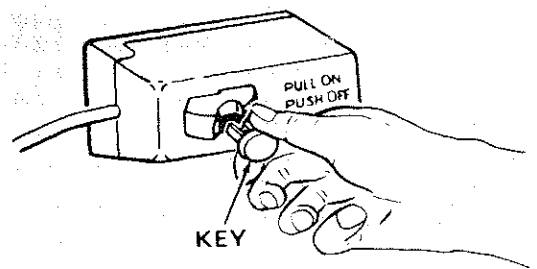
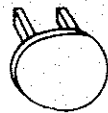

2. To turn machine on, insert finger under switch lever and pull end of switch out.

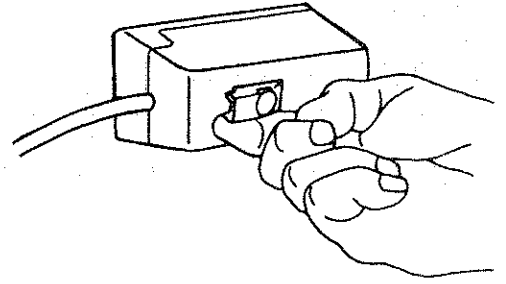

3. To turn machine OFF . . . PUSH lever in.

Never leave the machine unattended until it has come to a complete stop.

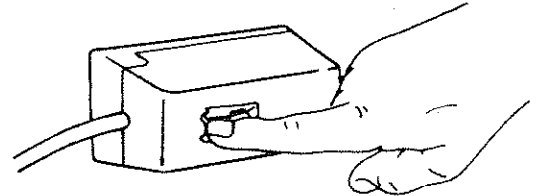

4. To lock switch in OFF position . . . hold switch IN with one hand . . . REMOVE key with other hand.

WARNING: FOR YOUR OWN SAFETY, ALWAYS LOCK THE SWITCH "OFF" WHEN MACHINE IS NOT IN USE . . . REMOVE KEY AND KEEP IT IN A SAFE PLACE . . . ALSO . . . IN THE EVENT OF A POWER FAILURE (ALL OF YOUR LIGHTS GO OUT) TURN SWITCH OFF . . . LOCK IT AND REMOVE THE KEY. THIS WILL PREVENT THE MACHINE FROM STARTING UP AGAIN WHEN THE POWER COMES BACK ON.

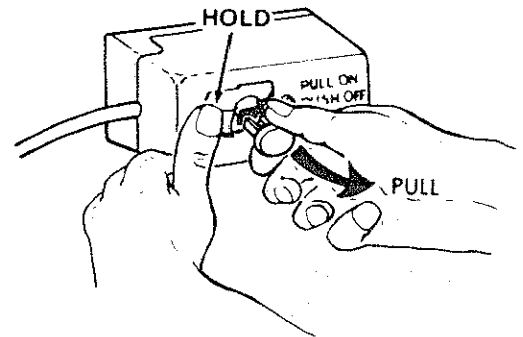

5. Find plastic cable hanger from among the loose parts.

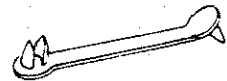

6. Route the motor cord behind the motor mount, across the top of the base and plug it into the receptacle in the side of the switch box.

7. Bring the power cord alongside the motor cord . . . wrap the plastic cable hanger around the cords and attach the hanger to the top of the base by pushing it into a 1/4" diameter hole.

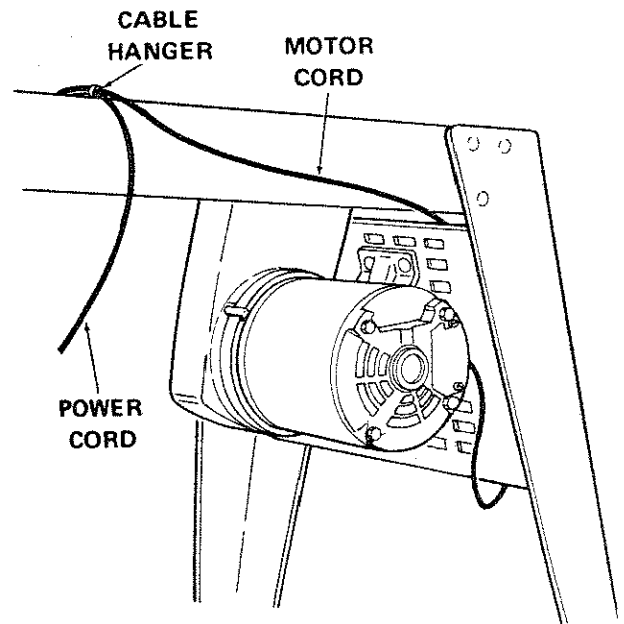

assembly

INSTALLING WORK TABLE

NOTE: Apply coat of paste wax to the work table. This will make it a little easier to feed the work.

1. Loosen the table positioning screw.
2. Insert the table support rod in the hole in the base until the edge of the table is approximately 1/16" from the abrasive disc. Tighten the screw.

NOTE: There is a second mounting hole in the base. This is for mounting the table when the belt is used in a vertical position.

WARNING: To avoid trapping the work or fingers between the table and sanding surface, the table edge should be a maximum 1/16 inch from the sanding surface, the table should be completely engaged on the rod.

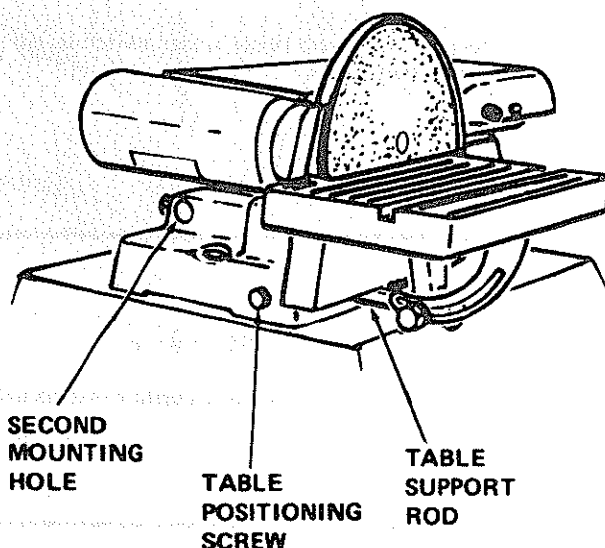

INSTALLING ABRASIVE BELT-TENSIONING AND TRACKING

WARNING: FOR YOUR OWN SAFETY, TURN SWITCH "OFF" AND REMOVE PLUG FROM POWER SOURCE OUTLET BEFORE REMOVING OR INSTALLING ABRASIVE BELT.

On the smooth side of the abrasive belt you will find a "directional arrow." The abrasive belt must run in the direction of this arrow so that the splice does not come apart.

1. Loosen the two abrasive belt LOCKING screws.
2. Place the abrasive belt over the pulleys with the directional arrow pointing as shown. Make sure the abrasive belt is centered on both pulleys.

Turning the abrasive belt ADJUSTING screws will cause the idler pulley to move in or out. When the idler pulley is moved outward, it puts TENSION on the belt.

3. Place both of the 1/2" wrenches on the ADJUSTING screws and pull the wrenches toward you. This will stretch the abrasive belt. Move the wrenches back and forth a few times so that you "get the feel" of the abrasive belt while it is stretching (TENSIONING).

Apply a small amount of TENSION to the abrasive belt by pulling the wrenches toward you, so that the TENSION feels the same on both wrenches.

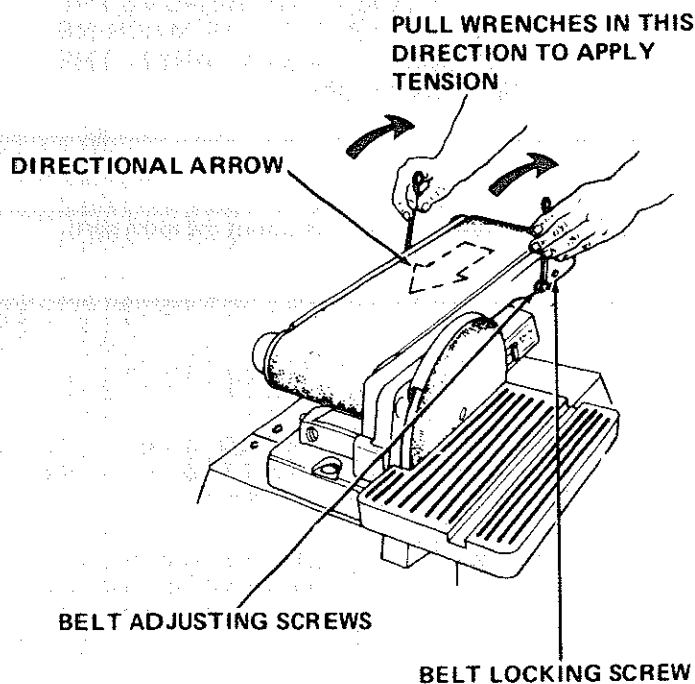

4. Hold the abrasive disc with your left hand to keep it from turning while pushing the belt in the direction of the arrow. If the abrasive belt slips over the pulleys, turn both ADJUSTING screws simultaneously a small amount to apply a little more tension to the abrasive belt.
5. Adjust the tension so that the abrasive belt does not slip very easily when pushing it, while you are holding the disc.
6. Tighten the locking screws.
7. Plug in the power cord. Turn the switch "ON", and immediately "OFF", noting if the belt moved to the right or to the left.
If it did not move to the right or left, it is TRACKING properly.

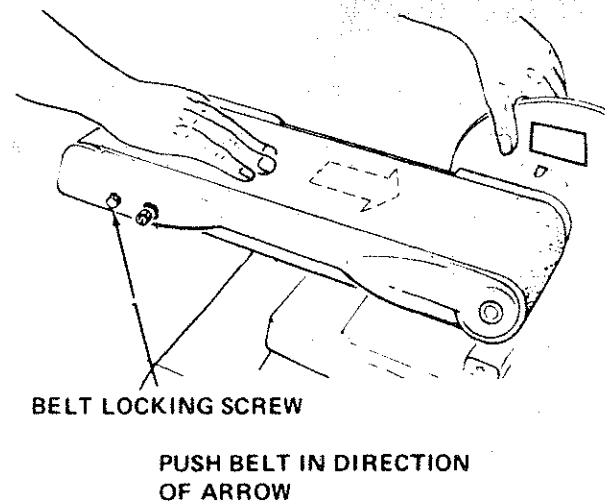

8. IF THE ABRASIVE BELT MOVES TO THE RIGHT:
 - a. Loosen the LOCKING SCREW on the RIGHT.
 - b. Place wrench on the ADJUSTING SCREW on the right.
 - c. Push abrasive belt so it is moving while pulling the wrench toward you. This will move the abrasive belt to the left. PUSHING the wrench will move the belt to the right.
 - d. The abrasive belt is tracking properly when it is centered on the DRIVE pulley.

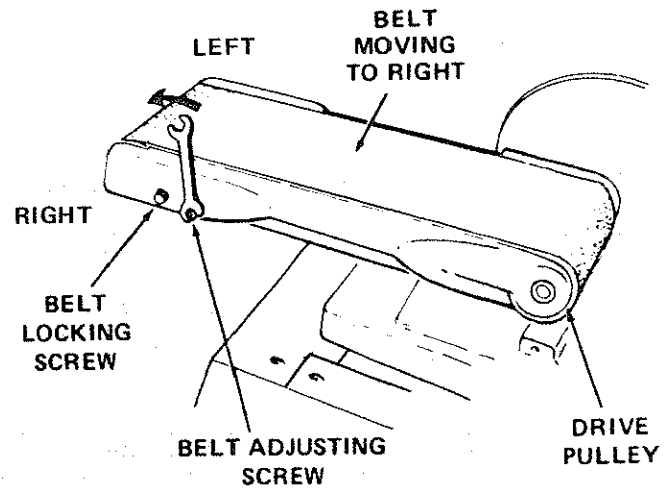

IMPORTANT: If you have difficulty tracking the abrasive belt, apply more tension.

9. IF THE ABRASIVE BELT MOVES TO THE LEFT:
 - a. Loosen the LOCKING SCREW on the LEFT.
 - b. Place wrench on the ADJUSTING SCREW on the left.
 - c. Push abrasive belt so it is moving while pulling the wrench toward you. This will move the abrasive belt to the right. PUSHING the wrench will move the abrasive belt to the left.
 - d. The abrasive belt is tracking properly when it is centered on the DRIVE pulley.

IMPORTANT: If you have difficulty tracking the abrasive belt, apply more tension.

INSTALLING BELT DUST TRAP

1. Find one 10 - 32 x 9/16" Pan Head screw and a lock-washer among the loose parts.

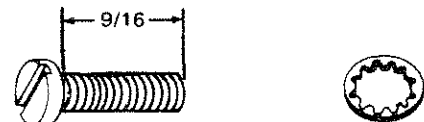

assembly

2. Attach the dust trap . . . make sure the top edge is below the surface of the abrasive belt.

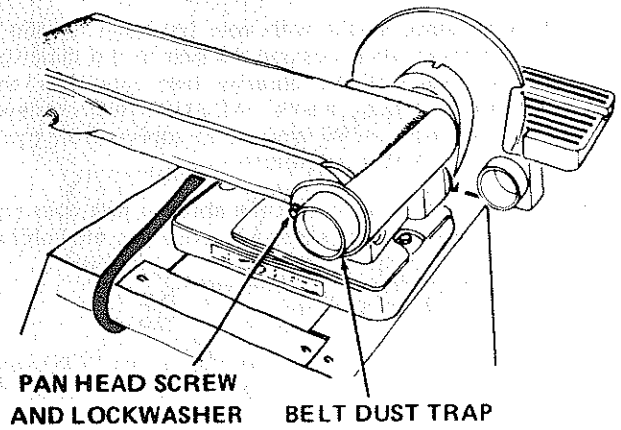

INSTALLING BACKSTOP

1. Find one 5/16" x 1" Hex. Head bolt and one flat washer among the loose parts.
2. Place the washer on the bolt, and screw it halfway into the mounting hole. Place the backstop into position and tighten the bolt. When removing the backstop, loosen the bolt but do not remove it.

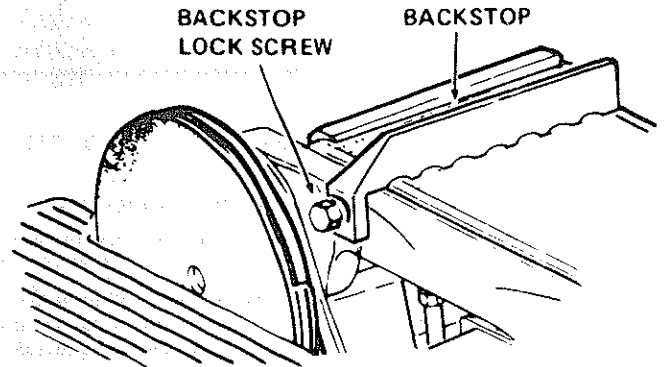

getting to know your belt and disc sander

WARNING: FOR YOUR OWN SAFETY TURN SWITCH "OFF" AND REMOVE PLUG FROM POWER SOURCE OUTLET BEFORE MAKING ANY ADJUSTMENTS.

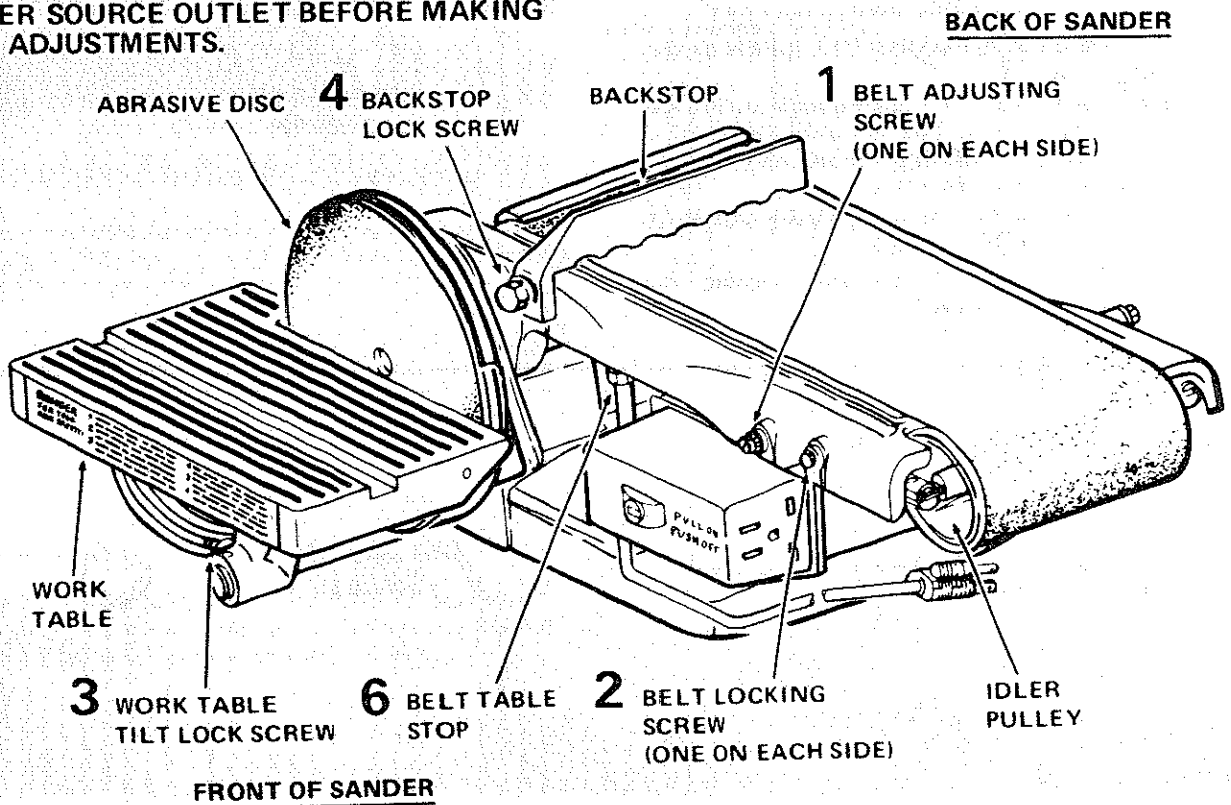

1. ABRASIVE BELT ADJUSTING SCREWS

cause the idler pulley to move in or out for applying tension to the abrasive belt or for tracking it. They are adjusted using the 1/2" wrenches.

See "Assembly" section . . . "Installing Abrasive Belt".

2. ABRASIVE BELT LOCKING SCREWS

lock the adjustment mechanism after the abrasive belt is tensioned and tracking properly. They are locked using the 1/2" wrench.

See "assembly" section . . . "Installing Abrasive Belt".

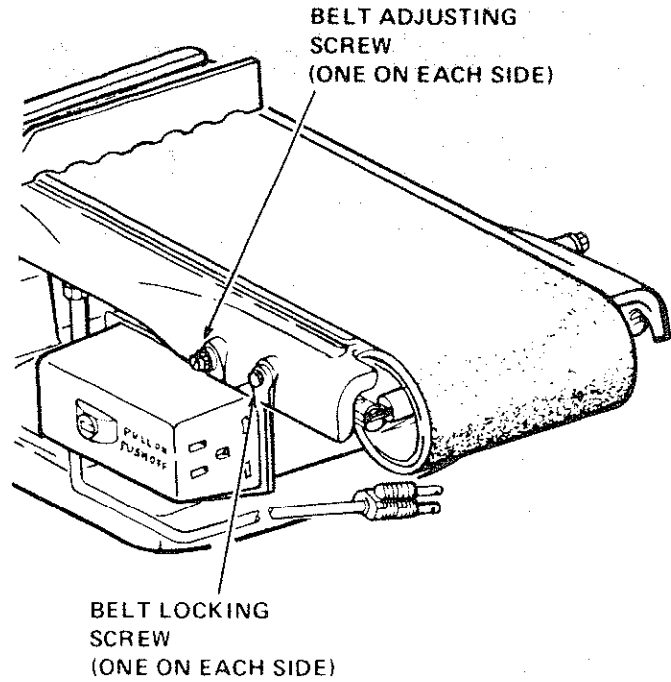

3. WORK TABLE TILT LOCK SCREW

locks the table. It is locked using the 1/2" wrench.

- Using a combination square, check the angle of the table with the disc.

NOTE: The combination square must be "true"—See start of assembly section on Pg. 6 for checking method.

- If the table is not 90° with the disc . . . loosen tilt lock screw and tilt table.
- Loosen the lock nut using a 7/16" wrench.
- Screw the stop screw in or out, using a 3/8" wrench so that when the table touches the stop screw, the table is 90° to the disc.
- Tighten the lock nut.

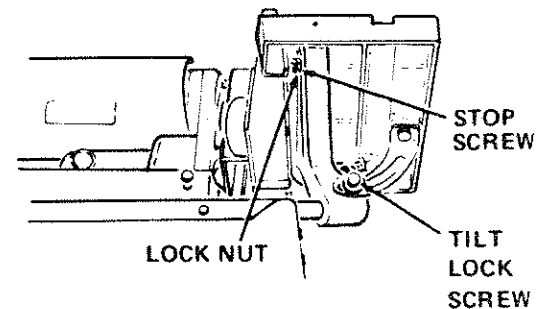
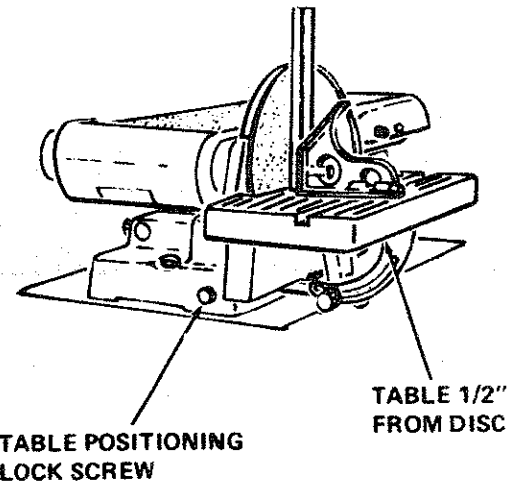

getting to know your belt and disc sander

- f. Loosen the table positioning lock screw . . . position the table approximately 1/16" away from the abrasive disc.
- g. Tilt the table downward but don't tighten the lock screw, and position it as close to the disc as possible. Using the head of a combination square, check the angle of the table with the disc.
- h. If the table is not 45° with the disc:

 - i. Raise the table and loosen the lock nut using a 7/16" wrench.
 - j. Screw the stop screw in or out, using a 3/8" wrench so that when the table touches it, it is 45° with the disc.

- k. Tighten the lock nut.

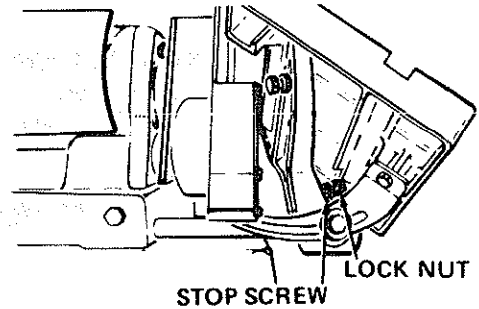
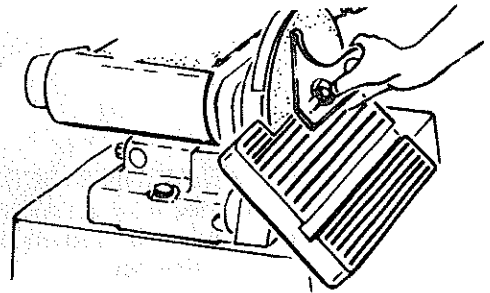

WARNING: To avoid trapping the work or fingers between the table and sanding surface, the table must be repositioned on the rod to maintain a maximum 1/16 inch space between the table and sanding surface.

4. **BACKSTOP LOCK SCREW** locks the backstop in place. It is locked using the 1/2" wrench.

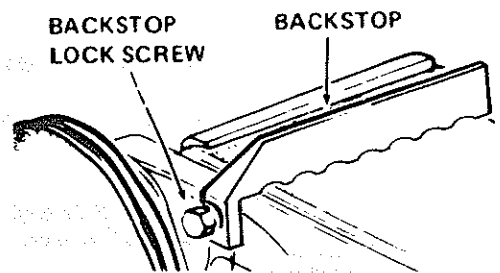

5. **BELT TABLE LOCKING BOLTS** . . . lock the belt table in position.

To adjust to vertical position:

- a. Remove the backstop.
- b. Loosen the two belt table locking bolts using the 1/2" wrench supplied with your machine.
- c. Position belt table vertically and tighten the two bolts.

6. **ABRASIVE BELT TABLE STOP** can be adjusted so that the abrasive belt table is level with the floor when in a horizontal position.

- a. Loosen the lock nut using a 3/4" wrench.
- b. Place a level on the abrasive belt table and using a 3/4" wrench, screw the stop bolt in or out until the table is level.

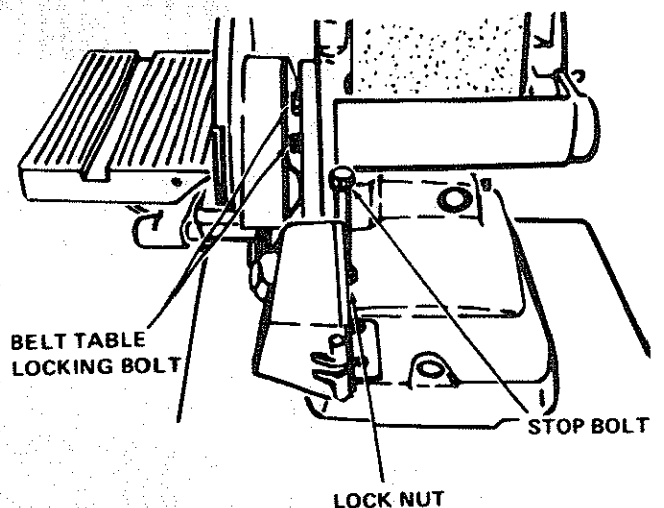

basic operation

BEFORE USING THE SANDER:

WARNING: To avoid mistakes that could cause serious, permanent injury, do not plug the sander in until the following steps are completed.

- Assembly. (See pages 7 - 16.)
- Learn the use and function of the ON-OFF switch, backstop lock screw, belt adjusting screws, belt locking screws, work table and work table tilt lock screw. (See pages 16 - 18.)
- Review and understanding of all safety instructions and operating procedures in this manual.
- Review of the maintenance methods for this sander. (See page 22.)

BEFORE EACH USE:

Inspect your sander.

DISCONNECT THE SANDER. To avoid injury from accidental starting, unplug the sander, turn the switch off and remove the switch key before changing the setup, sanding disc or belt or adjusting anything.

CHECK DAMAGED PARTS. Check for:

- alignment of moving parts,
- binding of moving parts,
- broken parts,
- stable mounting, and
- any other conditions that may affect the way the sander works.

If any part is missing, bent, or broken in any way, or any electrical parts don't work properly, turn the sander off and unplug the sander. REPLACE damaged, missing, or failed parts before using the sander again.

MAINTAIN TOOLS WITH CARE. Keep the sander clean for best and safest performance. Follow instructions for lubricating.

REMOVE ADJUSTING KEYS AND WRENCHES from tool before turning it on.

To avoid injury from jams, slips or thrown pieces:

- **USE ONLY RECOMMENDED ACCESSORIES.** (See page 22.) Consult this Owner's manual for recommended accessories. Follow the instructions that come with the accessories. The use of improper accessories may cause risk of injury to persons.
- Adjust table to clear the sanding surface by no more than 1/16 of an inch.
- Make sure all clamps and locks are tight and no parts have excessive play.
- **KEEP WORK AREA CLEAN.** Cluttered areas and benches invite accidents. Floor must not be slippery.

To avoid burns or other fire damage, never use the sander near flammable liquids, vapors or gases.

Plan ahead to protect your eyes, hands, face, ears.

KNOW YOUR SANDER. Read and understand the owner's manual and labels affixed to the tool. Learn its application and limitations as well as the specific potential hazards peculiar to this tool.

To avoid injury from accidental contact with moving parts, don't do layout, assembly, or setup work on the sander while any parts are moving.

AVOID ACCIDENTAL STARTING. Make sure switch is "OFF" before plugging sander into a power outlet.

Plan your work.

USE THE RIGHT TOOL. Don't force tool or attachment to do a job it was not designed to do.

CAUTION: This machine is not designed for heavy deburring operations. When finishing metals, sparks or hot fragments could cause a fire. To avoid this, disconnect any dust collecting hose from the sander. Also, remove all traces of wood dust from inside dust traps in the sander.

Dress for safety.

Any power sander can throw foreign objects into the eyes. This can cause permanent eye damage. Wear safety goggles (not glasses) that comply with ANSI Z87.1. Everyday eyeglasses have only impact resistant lenses. They are not safety glasses. Safety goggles are available at Sears retail catalog stores. Glasses or goggles not in compliance with ANSI Z87.1 could seriously hurt you when they break.

- Do not wear loose clothing, gloves, neckties or jewelry (rings, wrist watches). They can get caught and draw you into moving parts.
- Wear nonslip footwear.
- Tie back long hair.
- Roll long sleeves above the elbow.
- Noise levels vary widely. To avoid possible hearing damage, wear ear plugs or muffs when using sander for hours at a time.
- Sanding operations are usually dusty. Wear a dust mask along with the safety goggles.

Inspect your workpiece.

Make sure there are no nails or foreign objects in the part of the workpiece to be sanded.

Plan your work to avoid THROWBACKS—when the workpiece catches on the sanding belt or disc and is torn from your hands.

- Make sure there's no debris between the workpiece and its supports.
- When sanding irregularly shaped workpieces, plan your work support so it will not slip and be pulled from your hands.

Use extra caution with large, very small or awkward workpieces:

- Never use this tool to finish pieces too small to hold by hand.
- Use extra supports (tables, saw horses, blocks, etc.) for any workpieces large enough to tip when not held down to the table top.
- NEVER use another person as a substitute for a table extension, or as additional support for a workpiece that is longer or wider than the basic sander table, or to help feed, support or pull the workpiece.
- When finishing on the Disc, always press the workpiece against the "Down" side of the disc. Sanding against the side coming up from under the table could damage the work by making it "chatter," or tear the work from your hands and throw it.
- Sand only one workpiece at a time.
- Clear everything except the workpiece and related support devices off the table before turning the sander on.

basic operation

Plan the way you will hold the workpiece from start to finish. Avoid awkward operations and hand positions where a sudden slip could cause fingers or hand to move into a sanding surface. Keep fingers away from where the belt goes into the dust trap.

DON'T OVERREACH. Keep good footing and balance.

Keep your face and body to one side, out of line with a possible throwback.

WHENEVER SANDER IS RUNNING

WARNING: Don't let familiarity (gained from frequent use of your belt and disc sander) cause a careless mistake. A careless fraction of a second is enough to cause a severe injury.

Before starting your cut, watch the sander while it runs. If it makes an unfamiliar noise or vibrates a lot, stop immediately. Turn the sander off. Unplug the sander. Do not restart until finding and correcting the problem.

Make sure the sanding disc turns counterclockwise before using the sander.

KEEP CHILDREN AWAY. Keep all visitors a safe distance from the sander. Make sure bystanders are clear of the sander and workpiece.

DON'T FORCE TOOL. It will do the job better and safer at its designated rate. Press the workpiece against the sanding material only hard enough to let it sand without bogging down or binding.

Before freeing any jammed material:

- Turn switch "OFF."
- Unplug the sander.
- Wait for all moving parts to stop.

To avoid throwback of the workpiece, use workpiece supports for all flat surface sanding.

BEFORE LEAVING THE SANDER:

Wait for all moving parts to stop.

Make workshop child-proof. Lock the shop. Disconnect master switches. Remove the yellow switch key. Store it away from children and others not qualified to use the tool.

SURFACE FINISHING ON THE ABRASIVE BELT.

FLAT SURFACES

Hold the work piece firmly with both hands, keeping fingers away from the abrasive belt.

Keep the end butted against the backstop and move the work evenly across the abrasive belt. Use extra caution when finishing very thin pieces.

For finishing long pieces, remove the backstop.

Apply only enough pressure to allow the abrasive belt to remove material. If the abrasive belt stalls and the belt pulleys slip while applying moderate pressure to the workpiece, the abrasive belt requires more tension.

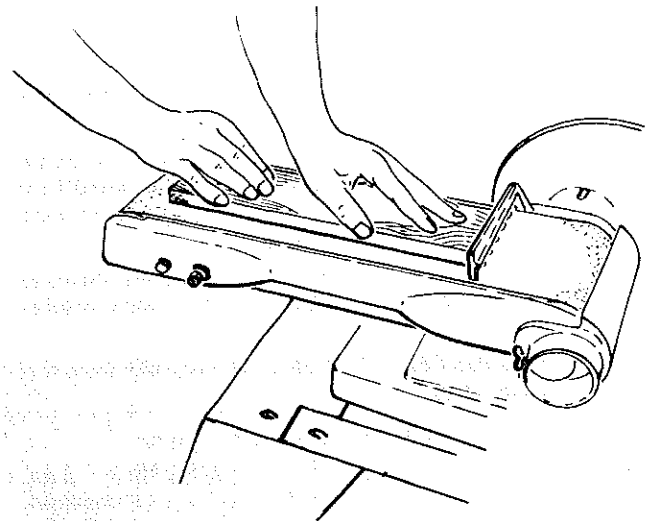

END FINISHING ON THE ABRASIVE BELT.

It is more convenient to finish the ends of long workpieces with the abrasive belt in a vertical position.

Move the work evenly across the abrasive belt. For accuracy, use a miter gauge.

The table may be tilted for beveled work.

See Getting To Know Your Finishing Machine section for adjusting the abrasive belt table and the work table.

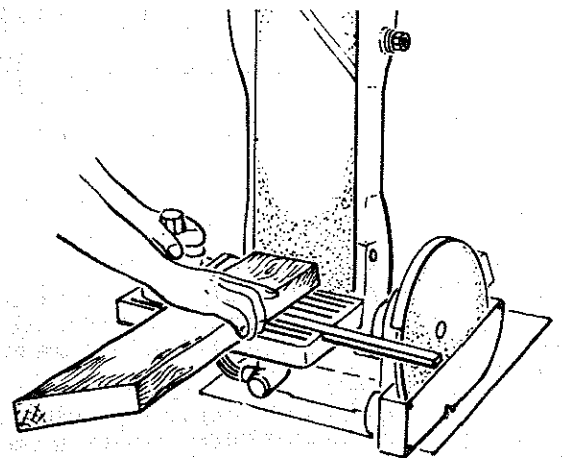

FINISHING CURVED EDGES ON THE ABRASIVE BELT CURVED EDGES

Finish outside curves on the abrasive belt and inside curves on the idler pulley.

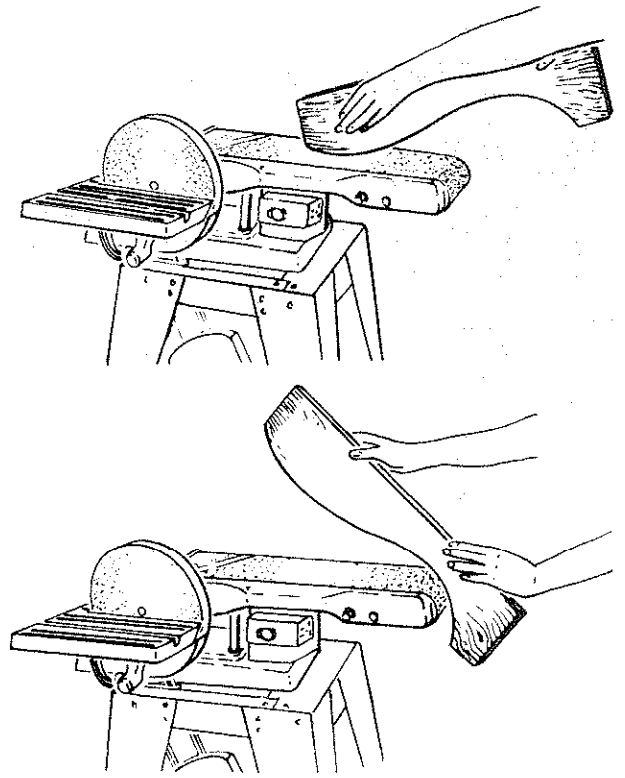

FINISHING SMALL END SURFACES AND CURVED EDGES ON THE ABRASIVE DISC

Move the work across the "Down Side" of the face of the abrasive disc. For accuracy, use a miter gauge.

NOTE: Use a combination square to square the miter gauge to the face of the disc. If it is not square, pull out the index pin, loosen the miter gauge knob and move the miter gauge slightly until it is square. Without moving the miter gauge, tighten the knob securely.

Applying the workpiece to the "Up Side" could cause it to fly up (kickback) which could be hazardous.

The table may be tilted for beveled work.

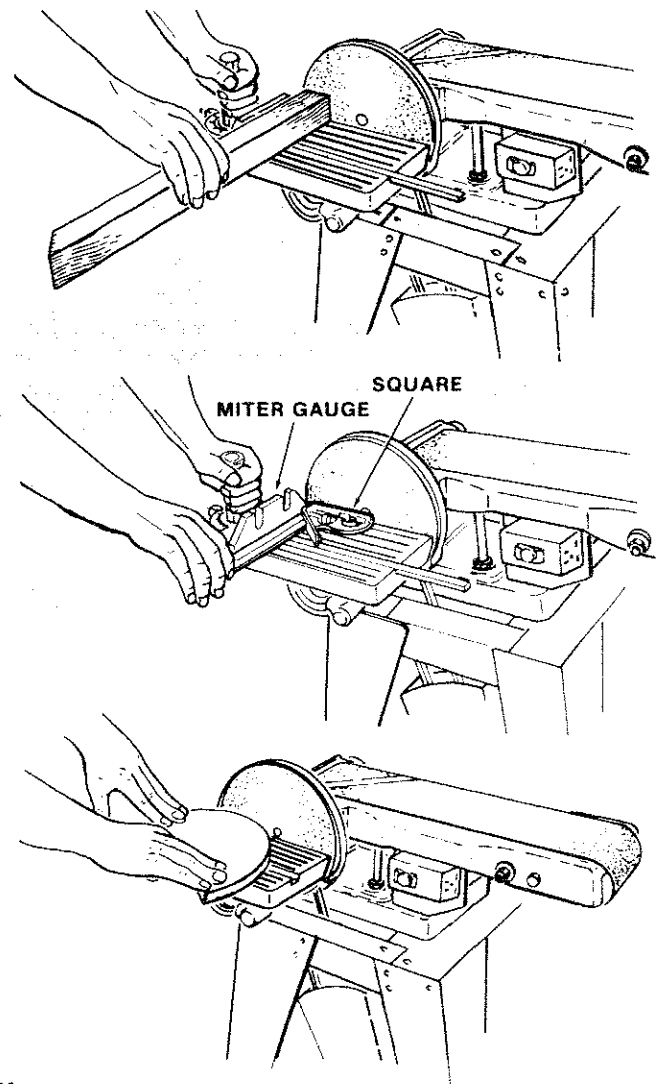

maintenance

WARNING: FOR YOUR OWN SAFETY, TURN SWITCH "OFF" AND REMOVE PLUG FROM POWER SOURCE OUTLET BEFORE ADJUSTING, MAINTAINING, OR LUBRICATING YOUR FINISHING MACHINE.

Keep your machine and your workshop clean. The dust traps around the abrasive disc and the abrasive belt are designed to deflect most of the fine dust. They should be connected to a Vac for most efficient dust removal.

WARNING: DO NOT ATTACH A VAC WHEN FINISHING IRON OR STEEL. THE SPARKS COULD IGNITE THE DEBRIS AND CAUSE A FIRE.

If power cord is worn or cut, or damaged in any way, have it replaced immediately.

Frequently blow out any dust that may accumulate inside the motor.

A coat of automobile-type wax applied to the worktable will make it a little easier to feed the work while finishing.

Do not apply wax to the abrasive belt table because the belt could pick up the wax and deposit it on the pulleys, causing the belt to slip.

MOTOR MAINTENANCE AND LUBRICATION

1. The bearings, in both end shields of the motor, have been lubricated at the factory with correct lubricant. No other part of the motor requires lubrication.
2. Re-lubricate motor bearings in accordance with the instructions on the nameplate. Be sure to wipe off dirt or grit if present around oil hole caps to prevent any possibility of foreign material contaminating the oil wicks that supply the bearings with oil. Use a good grade of medium weight mineral oil, such as automobile engine oil, SAE 20.
3. If disassembly of the motor is necessary, it should be returned to your nearest Sears retail or mail-order store in order to prevent voiding the guarantee.
NOTE: The speed of this motor cannot be regulated or changed.
4. Every effort should be made to prevent foreign material from entering the motor. When operated under conditions likely to permit accumulations of dust, dirt, or waste within the motor, a visual inspection should be made at frequent intervals. Accumulations of dry dust can usually be blown out successfully.

NOTE: Motors used on wood-working tools are particularly susceptible to the accumulation of sawdust and wood chips and should be blown out or "vacuumed" frequently to prevent interference with normal motor ventilation and proper operation of the centrifugally-operated starting switch.

Lubrication

The BEARINGS in this machine are packed with grease at the factory. They require no further lubrication.

Periodically lubricate the cams and shafts in the idler pulley mechanism with Silicon Spray.

SEARS RECOMMENDS THE FOLLOWING ACCESSORIES

ITEM	CAT. NO.
Steel Stand	9-22213
Caster Set	9-22222, 9-22221
Miter Gauge	9-29929
Pressure-Sensitive cement	9-2220
Abrasive Belts and Disc	SEE CATALOG
Steel Legs	9-22236
Power Tool Know How Handbooks	
Radial Saw	9-2917
Table Saw	9-2918

Sears may recommend other accessories not listed in the manual. See your nearest Sears store or catalog department for other accessories. Do not use any accessory unless you have received and read complete instructions for its use.

trouble shooting

WARNING: FOR YOUR OWN SAFETY, TURN SWITCH "OFF" AND REMOVE PLUG FROM POWER SOURCE OUTLET BEFORE TROUBLE SHOOTING YOUR SANDER.

TROUBLE SHOOTING CHART

TROUBLE	PROBABLE CAUSE	REMEDY
Motor will not run.	<ol style="list-style-type: none"> 1. Defective On-Off switch. Defective switch cord. Defective switch box receptacle. 2. Motor protector open, (only if your motor is equipped with an overload protector). 3. Burned out motor. 	<ol style="list-style-type: none"> 1. Replace defective parts before using belt disc sander again. 2. Reset protector after motor has cooled. 3. Consult Sears Service. Any attempt to repair this motor may create a HAZARD unless repair is done by a qualified service technician. Repair service is available at your nearest Sears Store.
Machine slows down when finishing.	<ol style="list-style-type: none"> 1. V-Belt too loose. 2. Applying too much pressure to workpiece. 3. Too much tension on abrasive belt. 	<ol style="list-style-type: none"> 1. Increase belt tension, see Assembly Section, "Motor Pulley Belt Guard and Motor Installation." 2. Ease up on pressure. 3. Adjust tension, see Assembly Section, "Installing and Adjusting Abrasive Belt."
Abrasive Belt Slips	<ol style="list-style-type: none"> 1. Not enough tension. 	<ol style="list-style-type: none"> 1. Adjust tension, see Assembly Section, "Installing and Adjusting Abrasive Belt."
Abrasive Belt runs off pulleys.	<ol style="list-style-type: none"> 1. Not tracking properly . 2. Not enough tension. 	<ol style="list-style-type: none"> 1. Adjust tracking, see Assembly Section, "Installing and Adjusting Abrasive Belt." 2. Adjust tension, see Assembly Section, "Installing and Adjusting Abrasive Belt."
Wood burns while finishing.	<ol style="list-style-type: none"> 1. Abrasive disc or belt is glazed with sap. 	<ol style="list-style-type: none"> 1. Replace disc or belt.

TROUBLE SHOOTING -- MOTOR

NOTE: Motors used on wood-working tools are particularly susceptible to the accumulation of sawdust and wood chips and should be blown out or "vacuumed" frequently to prevent interference with normal motor ventilation and proper operation of the centrifugally-operated starting switch.

TROUBLE	PROBABLE CAUSE	REMEDY
Excessive noise.	1. Motor.	1. Have motor checked by qualified service technician. Repair service is available at your nearest Sears store.
Motor fails to develop full power. NOTE: LOW VOLTAGE: (Power output of motor decreases rapidly with decrease in voltage at motor terminals. For example, a reduction of 10% in voltage causes a reduction of 19% in maximum power output of which the motor is capable, and a reduction of 20% in voltage causes a reduction of 36% in maximum power output.)	1. Circuit overloaded with lights, appliances and other motors. 2. Undersize wires or circuit too long. 3. General overloading of power company facilities.	1. Do not use other appliances or motors on same circuit when using the saw. 2. Increase wire sizes, or reduce length of wiring. See "Motor Specifications and Electrical Requirements" section. 3. Request a voltage check from the power company.
Motor starts slowly or fails to come up to full speed.	1. Low voltage will not trip relay. 2. Windings burned out or open. 3. Starting relay not operating.	1. Request voltage check from the power company. 2. Have motor repaired or replaced. 3. Have relay replaced.
Motor overheats.	1. Motor overloaded. 2. Improper cooling. (Air circulation restricted through motor due to sawdust, accumulating.)	1. Feed work slower into belt or disc. 2. Clean out sawdust to provide normal air circulation through motor. See "Maintenance and Lubrication" section.
Starting switch in motor will not operate.	1. Burned switch contacts (due to extended hold-in periods caused by low line voltage, etc.) 2. Shorted capacitor 3. Loose or broken connections.	1. Have switch replaced and request a voltage check from the power company. 2. Have capacitor tested and replace if defective. 3. Have wiring checked and repaired.
Motor stalls (resulting in blown fuses or tripped circuit breakers).	1. Starting switch not operating. 2. Voltage too low to permit motor to reach operating speed. 3. Fuses or circuit breakers do not have sufficient capacity.	1. Have switch replaced. 2. Request voltage check from the power company. 3. Install proper size fuses or circuit breakers.
Frequent opening of fuses or circuit breakers.	1. Motor overloaded. 2. Fuses or circuit breakers do not have sufficient capacity. 3. Starting switch not operating (motor does not reach speed).	1. Feed work slower into belt or disc. 2. Install proper size fuses or circuit breakers. 3. Have switch replaced.

repair parts

CRAFTSMAN BELT AND DISC SANDER MODEL NO. 113.225900 & 113.225931

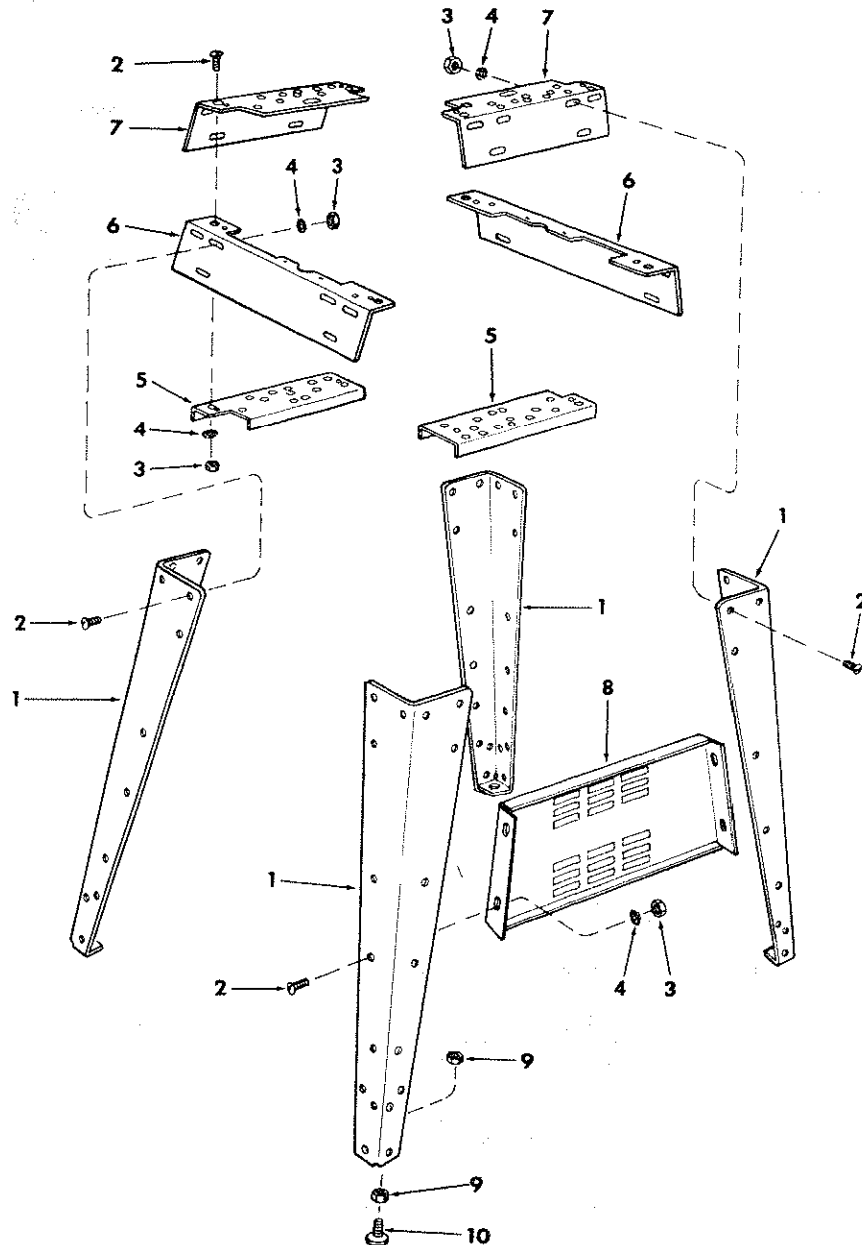

**FIGURE 1 PARTS LIST
SUPPLIED WITH MODEL 113.225931 ONLY**

Key No.	Part No.	Description
1	62614	Leg
2	60314	† Screw, Truss Hd. 1/4-20 x 5/8
3	STD541025	†* Nut, Hex 1/4-20
4	STD551225	†* Lockwasher, 1/4 External
5	68060	Channel, Support
6	68059	Stiffener, Side
7	62615	Stiffener, End
8	68061	Support, Motor
9	STD541050	†* Nut, Hex 1/2-13
10	803835	† Foot, Leveling
-	68062	† Bag of Loose Parts (Not illustrated)

Key No.	Part No.	Description
HARDWARE FOR MOUNTING TOOL & MOTOR		
-	STD523125	†*Screw, Hex Hd. 5/16-18 x 2-1/2
-	STD551131	†*Lockwasher, External 5/16
-	STD541231	†*Nut, Hex Jam 5/16 x 18
-	STD551031	†*Washer, 11/32 x 11/16 x 1/16
-	STD532507	†*Bolt, Carriage 5/16-18 x 3/4

†These items all contained in Loose Parts Bag, Part No. 68062.

*Standard Hardware Item - May be Purchased Locally.

CRAFTSMAN BELT AND DISC SANDER MODEL NO. 113.225900 & 113.225931

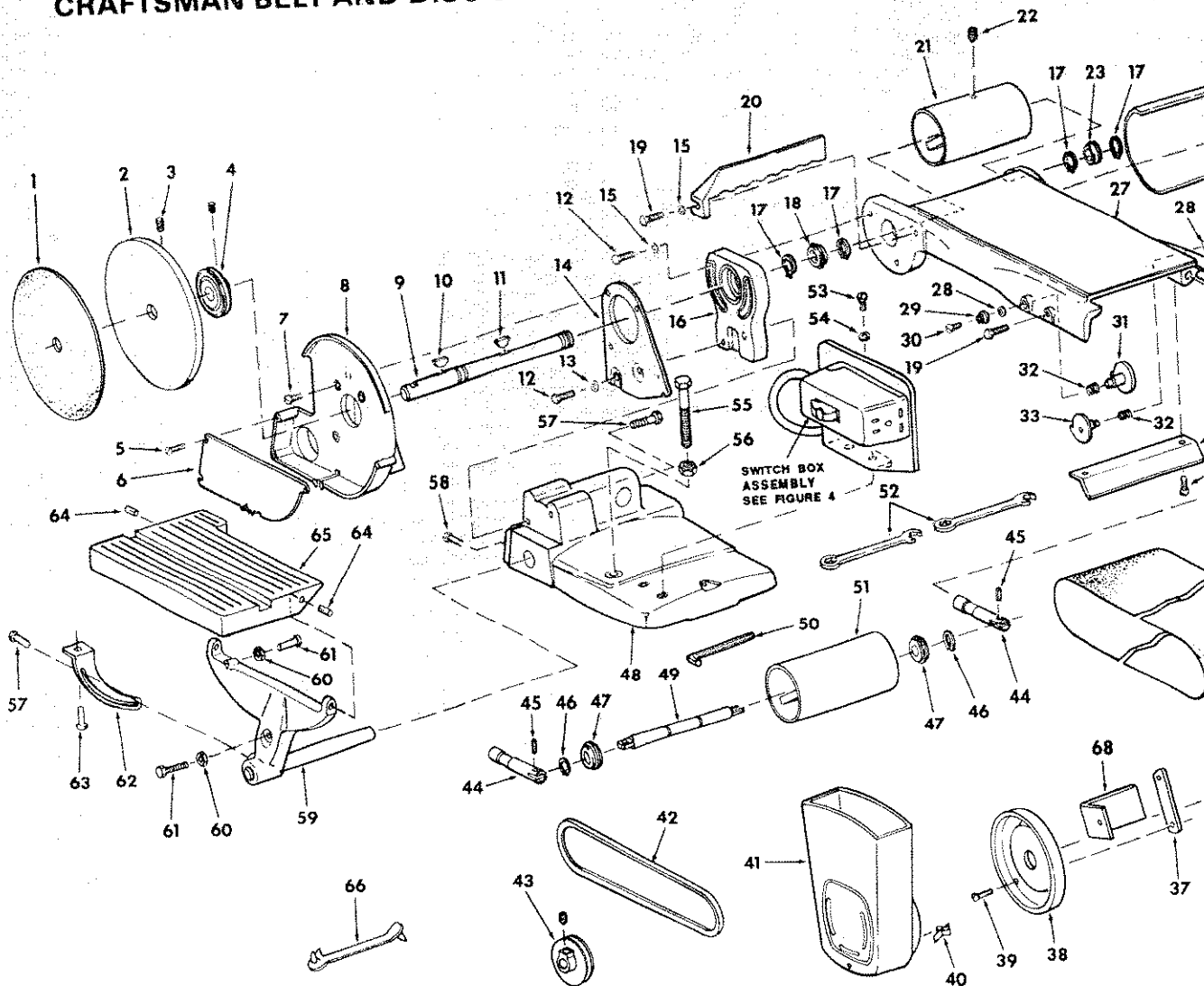

FIGURE 2

CRAFTSMAN BELT AND DISC SANDER MODEL NO. 113.225900 & 113

FIGURE 2 PARTS LIST

Key No.	Part No.	Description	Key No.	Part No.	Description
1	38834	† Disc, 9 Inch Abrasive	36	47813	† Belt, Sanding
2	68033	Disc, Sanding (w/Set Screw)	37	60254	Bracket, Support
3	STD503103	* Screw, Socket Head Set, 5/16-18 x 5/16	38	60253	Support, Belt Gua
4	30646	† Pulley (w/Set Screw) 2-1/2 dia. x 1/2, "V" Groove 5/8 bore, Keyed	39	STD601105	* Screw, Type 23 Pa No. 10-32 x 1/2 "S" Clip
5	STD600803	* Screw, Type 23, Pan No. 8-32 x 3/8	40	60255	Guard, Belt
6	68003	Cover, Housing	41	60252	† V-Belt, 1/2 x 41"
7	133656	* Screw, Machine Flat Head No. 10-32 x 1-3/4	42	STD304410	† Pulley, (w/Set Scr "V" Groove 5/8 B
8	68004	Housing, Disc	43	62023	Shaft, Control
9	68069	Shaft, Drive	44	47622	Pin, Roll 3/16 x 5
10	STD580025	Key, Woodruff, No. 9	45	STD571807	Ring, Retaining 5/
11	38812	Key, Woodruff	46	38538	Bearing, Ball
12	STD523115	* Screw, Hex Head 5/16-18 x 1-1/2	47	38536	Base
13	STD551131	* Lockwasher, 5/16	48	68015	Shaft, Idler
14	68005	Bracket, Mounting	49	47621	* Wrench Hex., 5/32
15	STD551031	* Washer, 21/64 x 7/8 x 1/8	50	60096	Pulley, Idler
16	68068	Bracket, Table Support	51	47414	Wrench
17	37158	Ring, Retaining 5/8	52	68017	* Screw, Machine Pa
18	60434	Bearing, Ball	53	STD512505	* Lockwasher, 1/4
19	STD523110	* Screw, Machine Hex Head 5/16-18 x 1	54	STD551125	* Bolt, Hex. Head, 1
20	47222	Backstop	55	100167	* Nut, Hex., 1/2-13
21	47190	Pulley, Drive (w/Set Screw)	56	STD541250	Bolt, High Strengt
22	STD502502	* Screw, Socket Head Set, 1/4-20 x 5/16	57	STD523107	Bolt, High Strengt
23	3509	Bearing Ball	58	STD523122	Support Assembly
24	68006	Trap, Dust	59	68016	* Nut, Hex., 1/4-20
25	STD551210	* Lockwasher No. 10 Int. Tooth	60	STD541025	* Screw, Machine H
26	STD511105	* Screw Mach. Pan Hd. 10-32 x 9/16	61	STD522512	Bracket, Table Lo
27	68070	Table, Belt	62	38738	* Screw, Ty "T" 5/
28	STD551037	* Washer, 3/8 x 3/4 x 1/16	63	9416187	Hex. Head
29	68007	Nut, Cam	64	STD571812	* Pin, Roll 3/16 x 1
30	STD510605	* Screw, Machine Pan Slotted No. 6-32 x 7/16	65	68055	Table, Work
31	68008	Cam, Left Hand	66	68036	Hanger, Cable
32	47815	Spring	67	68072	Motor (Model 113
33	68009	Cam, Right Hand	68	69184	Bracket, Mountin
34	68010	Guard, Idler		68073	Owner's Manual (I
35	STD510803	* Screw, Machine Pan Head No. 8-32 x 3/8		68035	Bag of Loose Part
				68064	Bag of Loose Part

* Standard Hardware Item - May Be Purchased Locally.

† Stock Item - May be secured through the Hardware Department of most Sears or Catalog Order Houses

repair parts

CRAFTSMAN BELT AND DISC SANDER MODEL 113.225931

NOTE:

ANY ATTEMPT TO REPAIR THIS MOTOR
MAY CREATE A HAZARD UNLESS
REPAIR IS DONE BY QUALIFIED
SERVICE TECHNICIAN.

REPAIR SERVICE IS AVAILABLE
AT YOUR NEAREST SEARS STORE.

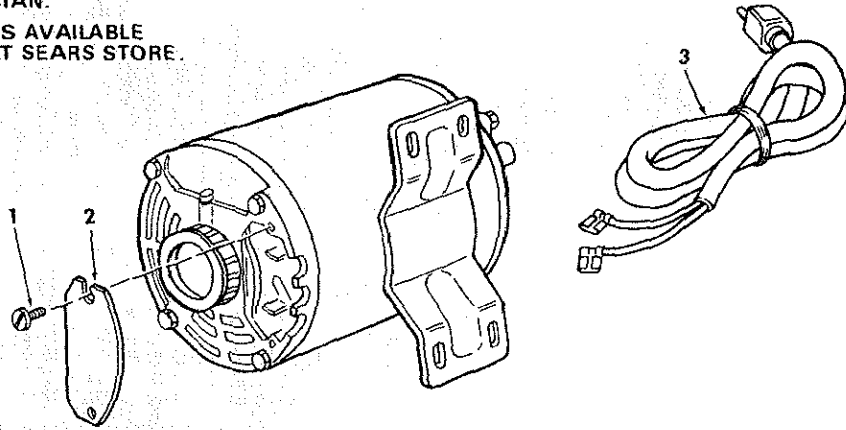

**FIGURE 3 - MOTOR PART NO. 68072
SUPPLIED WITH MODEL 113.225931 ONLY**

Key No.	Part No.	Description
1	60306	Screw, 8-32 x 3/8, Thread Cutting, Slotted, Serrated Hd.
2	64088	Cover, Terminal
3	64258	Cord with Plug

MOTOR CONNECTIONS

WARNING: FOR YOUR OWN SAFETY, TURN SWITCH "OFF" AND REMOVE PLUG FROM POWER SOURCE OUTLET BEFORE PROCEEDING.

1. Open motor connector box cover located on left end of motor (viewed from rear of saw) using a flat blade screwdriver.
2. Remove GREEN SCREW and lockwasher and insert screw through round metal terminal on the end of the GREEN wire of power cord with lockwasher between terminal and motor frame. (See illus.)
3. Reinsert GREEN SCREW in the threaded hole. Tighten securely.
4. Insert terminal end of WHITE wire on spade terminal marked T4 on the motor. Push terminal firmly until seated.
5. Insert terminal end of BLACK wire on spade terminal marked T1 on the motor. Push terminal firmly until seated.
6. Close motor connector box being sure that power cord is seated in the largest strain relief groove, and tighten box cover screws.

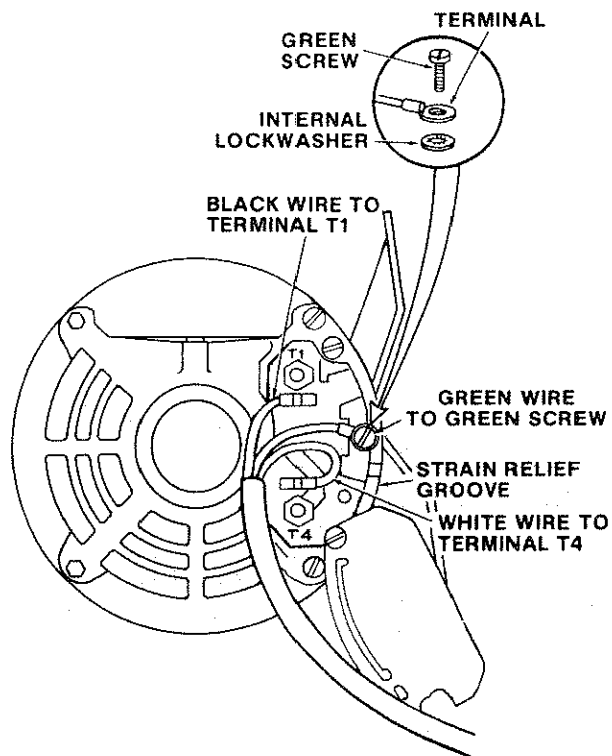

repair parts

CRAFTSMAN BELT AND DISC SANDER MODEL NO. 113.225900 & 113.225931

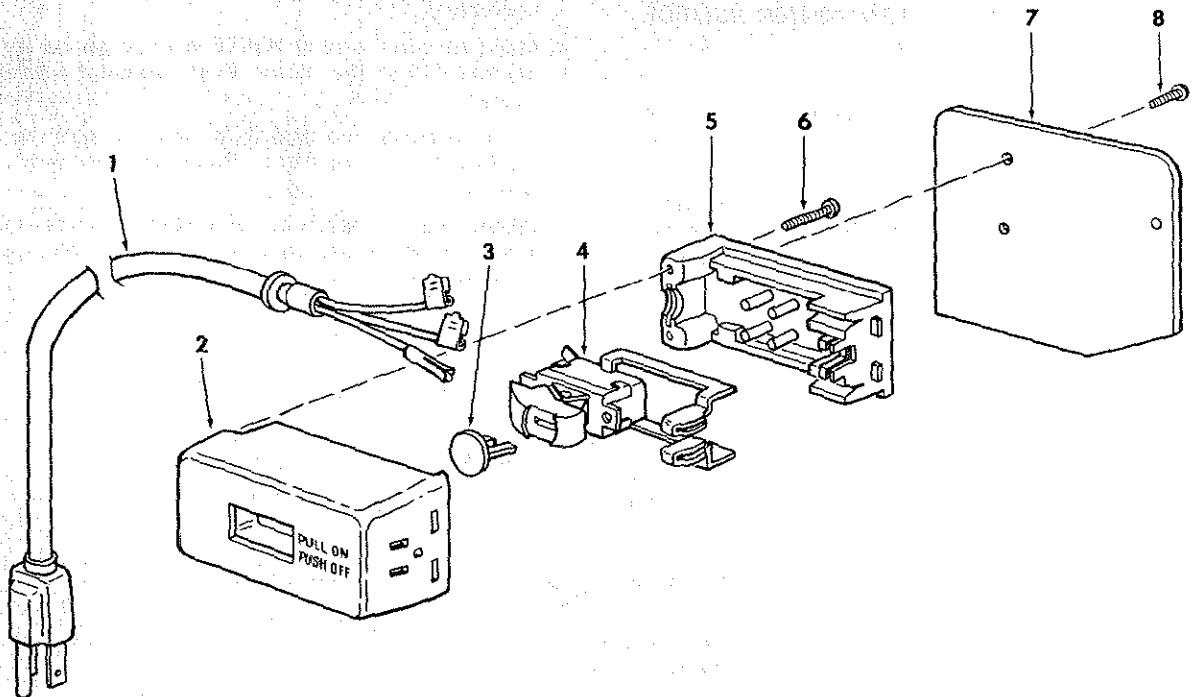

**FIGURE 4 PARTS LIST
ON/OFF POWER OUTLET 60382 AND
MOUNTING BRACKET**

Key No.	Part No.	Description
—	60382	• On/Off Power Outlet
1	60375	Cord, Molded
2	60378	Housing, Switch
3	9-22255	†Key, Switch
4	60374	Switch, Locking
5	60376	Cover, Switch
6	448007	Screw, Pan Hd. No. 6 x 3/4
7	68066	Bracket, Switch Mounting
8	STD600803	*Screw, Pan Hd. Plastite No. 8 x 3/8

*Standard Hardware Item — May be Purchased Locally.

• Does Not Include Key No. 3.
Order Separately If Required.

†Stock Item—May be secured through the Hardware Department of most Sears Retail Stores or Catalog Order Houses.

NOTE: Shipping and handling charges for standard hardware items (identified by *) such as nuts, screws, washers, etc., make buying these items by mail uneconomical. To avoid shipping and handling charges, you may obtain most of these locally.

SEARS

owners manual

SERVICE

**MODEL NO.
113.225900**

BELT AND DISC
SANDER ONLY

**MODEL NO.
113.225931**

BELT AND DISC
SANDER/WITH
LEGS AND MOTOR

HOW TO ORDER REPAIR PARTS

BELT AND DISC SANDER

Now that you have purchased your Belt & Disc Sander should a need ever exist for repair parts or service, simply contact any Sears Service Center and most Sears, Roebuck and Co. stores. Be sure to provide all pertinent facts when you call or visit.

The model number of your Belt and Disc Sander will be found on a plate attached to your sander at the right-hand side of the base.

WHEN ORDERING REPAIR PARTS, ALWAYS GIVE THE FOLLOWING INFORMATION:

PART NUMBER	PART DESCRIPTION
MODEL NUMBER 113.225900 OR 113.225931	NAME OF ITEM Belt And Disc Sander

All parts listed may be ordered from any Sears Service Center and most Sears stores. If the parts you need are not stocked locally, your order will be electronically transmitted to a Sears Repair Parts Distribution Center for handling.

Sold by SEARS, ROEBUCK AND CO., Chicago, IL. 60684 U.S.A.