

This Owner's Manual is provided and hosted by [Appliance Factory Parts](#).



EMPIRE BF-30W-1 Owner's Manual

[Shop genuine replacement parts for EMPIRE BF-30W-1](#)



[Find Your EMPIRE Heater Parts - Select From 16 Models](#)

----- Manual continues below -----



INSTALLATION INSTRUCTIONS

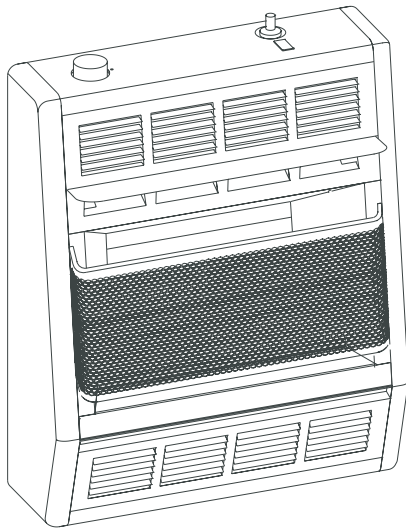

UNVENTED ROOM HEATER MODELS

BF-10W-1 | BF-20W-1 | BF-30W-1

GAS-FIRED



LISTED

UL FILE NO. MH46389

INSTALLER:

Leave this manual with the appliance.

CONSUMER:

Retain this manual for future reference.

⚠ WARNING

FIRE OR EXPLOSION HAZARD

If the information in this manual is not followed exactly, a fire or explosion may result causing property damage, personal injury or loss of life.

- Do not store or use gasoline or other flammable vapors and liquids in the vicinity of this or any other appliance.
- **WHAT TO DO IF YOU SMELL GAS**
 - Do not try to light any appliance.
 - Do not touch any electrical switch; do not use any phone in your building.
 - Leave the building immediately.
 - Immediately call your gas supplier from a neighbor's phone. Follow the gas supplier's instructions.
 - If you cannot reach your gas supplier, call the fire department.
- Installation and service must be performed by a qualified installer, service agency or the gas supplier.

This appliance may be installed in an aftermarket, permanently located, manufactured (mobile) home, where not prohibited by local codes.

This appliance is only for use with the type of gas indicated on the rating plate. This appliance is not convertible for use with other gases.

This is an unvented gas-fired heater. It uses air (oxygen) from the room in which it is installed. Provisions for adequate combustion and ventilation air must be provided.

⚠ WARNING

If not installed, operated and maintained in accordance with the manufacturer's instructions, this product could expose you to substances in fuel or from fuel combustion which can cause death or serious illness.

WATER VAPOR: A BY-PRODUCT OF UNVENTED ROOM HEATERS

Water vapor is a by-product of gas combustion. An unvented room heater produces approximately one (1) ounce (30ml) of water for every 1,000 Btu (.3KW's) of gas input per hour.

TABLE OF CONTENTS

SECTION	PAGE
Important Safety Information.....	3
Safety Information for Users of Propane Gas.....	4
Introduction.....	5
Specifications.....	5
Water Vapor: A By-Product of Unvented Room Heaters.....	6
Provisions for Adequate Combustion and Ventilation Air.....	6
Gas Supply.....	7
Clearances.....	8
Optional Floor Stand Installation.....	8
Wall Mount Installation.....	9
Lighting Instructions.....	10
Main Burner Flame Characteristics.....	11
Important Soot Prevention Steps.....	11
Pilot Flame Characteristics.....	12
Thermostat Operation.....	12
Appliance Maintenance.....	13
Troubleshooting.....	14
Parts List.....	15
Parts View.....	16
Optional Blower Installation Instructions.....	17-18
Master Parts Distributor List.....	19
How To Order Repair Parts.....	19

IMPORTANT SAFETY INFORMATION

THIS IS A HEATING APPLIANCE
DO NOT OPERATE THIS APPLIANCE WITHOUT FRONT PANEL INSTALLED.

⚠ DANGER: Indicates a hazardous situation which, if not avoided, will result in death or serious injury.

⚠ WARNING: Indicates a hazardous situation which, if not avoided, could result in death or serious injury.

⚠ CAUTION: Indicates a hazardous situation which, if not avoided, could result in minor or moderate injury.

⚠ WARNING: Do not allow fans to blow directly into the heater. Avoid any drafts that alter burner flame patterns.

⚠ WARNING: FIRE, EXPLOSION, AND ASPHYXIATION HAZARD. Improper adjustment, alteration, service, maintenance, or installation of this heater or its controls can cause death or serious injury.

Read and follow instructions and precautions in User's Information Manual provided with this heater.

NOTICE: Addresses practices not related to personal injury.

- This appliance is intended for supplemental heating.
- If the barrier becomes damaged, the barrier shall be replaced with the manufacturer's barrier for this appliance.
- An unvented room heater having an input rating of more than 6,000 Btu per hour shall not be installed in a bathroom.
- An unvented room heater having an input rating of more than 10,000 Btu per hour shall not be installed in a bedroom or bathroom.
- Due to high temperatures, the appliance should be located out of traffic and away from furniture and draperies.
- Children and adults should be alerted to the hazard of high surface temperature and should stay away to avoid burns or clothing ignition.

- Young children should be carefully supervised when they are in the same room with the appliance.
- Do not place clothing or other flammable material on or near the appliance.
- Due to high surface temperatures, keep children, clothing and furniture away.
- **⚠ WARNING:** Do not use a blower insert, heat exchanger insert or other accessory not approved for use with heater.
- Installation and repair should be done by a **QUALIFIED SERVICE PERSON**. The appliance should be inspected before use and at least annually by a professional service person. More frequent cleaning may be required due to excessive lint from carpeting, bedding materials, etc. It is imperative that control compartments, burners and circulating air passageways of the appliance be kept clean.
- **DO NOT** use this room heater if any part has been under water. Immediately call a qualified service technician to inspect the room heater and to replace any part of the control system and any gas control which has been under water.
- Keep appliance area clear and free from combustible materials, gasoline and other flammable vapors and liquids.
- **⚠ WARNING: ANY CHANGE TO THIS HEATER OR ITS CONTROLS CAN BE DANGEROUS.**
Any safety screen or guard removed for servicing an appliance must be replaced prior to operating the heater.
- **⚠ WARNING:** Failure to keep the primary air opening(s) of the burner(s) clean may result in sooting and property damage.

⚠ WARNING

CARBON MONOXIDE POISONING HAZARD

Failure to follow the steps outlined below for each appliance connected to the venting system being placed into operation could result in carbon monoxide poisoning or death. The following steps shall be followed for each appliance connected to the venting system being placed into operation, while all other appliances connected to the venting system are not in operation:

1. Seal any unused openings in the venting system.
2. Inspect the venting system for proper size and horizontal pitch, as required in the National Fuel Gas Code, ANSI Z223.1/NFPA 54 or the Natural Gas and Propane Installation Code, CSA B149.1 and these instructions. Determine that there is no blockage or restriction, leakage, corrosion and other deficiencies which could cause an unsafe condition.
3. As far as practical, close all building doors and windows and all doors between the space in which the appliance(s) connected to the venting system are located and other spaces of the building.
4. Close fireplace dampers.
5. Turn on clothes dryers and any appliance not connected to the venting system. Turn on any exhaust fans, such as range hoods and bathroom exhausts, so they are operating at maximum speed. Do operate a summer exhaust fan.
6. Follow the lighting instructions. Place the appliance being inspected into operation. Adjust the thermostat so appliance is operating continuously.
7. Test for spillage from draft hood equipped appliances at the draft hood relief opening after 5 minutes of main burner operation. Use the flame of a match or candle.
8. If improper venting is observed during any of the above tests, the venting system must be corrected in accordance with National Fuel Gas Code, ANSI Z223.1/NFPA 54 and/or Natural Gas and Propane Installation Code, CSA B149.1.
9. After it has been determined that each appliance connected to the venting system properly vents when tested as outlined above, return doors, windows, exhaust fans, fireplace dampers and any other gas-fired burning appliance to their previous conditions of use.

SAFETY INFORMATION FOR USERS OF PROPANE GAS

Propane is a flammable gas which can cause fires and explosions. In its natural state, propane is odorless and colorless. You may not know all the following safety precautions which can protect both you and your family from an accident. Read them carefully now, then review them point by point with the members of your household. Someday when there may

not be a minute to lose, everyone's safety will depend on knowing exactly what to do. If, after reading the following information, you feel you still need more information, please contact your gas supplier.

PROPANE GAS WARNING ODOR

If a gas leak happens, you should be able to smell the gas because of the odorant put in the Propane Gas. That's your signal to go into immediate action!

- Do not operate electric switches, light matches, use your phone. Do not do anything that could ignite the gas.
- Get everyone out of the building, vehicle, trailer, or area. Do that IMMEDIATELY.
- Close all gas tank or cylinder supply valves.
- Propane Gas is heavier than air and may settle in low areas such as basements. When you have reason to suspect a gas leak, keep out of basements and other low areas. Stay out until firefighters declare them to be safe.
- Use your neighbor's phone and call a trained Propane Gas service person and the fire department. Even though you may not continue to smell gas, do not turn on the gas again. Do not re-enter the building, vehicle, trailer, or area.
- **Finally**, let the service man and firefighters check for escaped gas. Have them air out the area before you return. Properly trained Propane Gas service people should repair the leak, then check and relight the gas appliance for you.

NO ODOR DETECTED - ODOR FADE

Some people cannot smell well. Some people cannot smell the odor of the chemical put into the gas. You must find out if you can smell the odorant in propane. Smoking can decrease your ability to smell. Being around an odor for a time can affect your sensitivity or ability to detect that odor. Sometimes other odors in the area mask the gas odor. People may not smell the gas odor or their minds are on something else. Thinking about smelling a gas odor can make it easier to smell.

The odorant in Propane Gas is colorless, and it can fade under some circumstances. For example, if there is an underground leak, the movement of the gas through soil can filter the odorant. Odorants in Propane Gas also are subject to oxidation. This fading can occur if there is rust inside the storage tank or in iron gas pipes.

The odorant in escaped gas can adsorb or absorb onto or into walls, masonry and other materials and fabrics in a room. That will take some of the odorant out of the gas, reducing its odor intensity.

Propane Gas may stratify in a closed area, and the odor intensity could vary at different levels. Since it is heavier than air, there may be more odor at lower levels. Always be sensitive to the slightest gas odor. If you detect any odor, treat it as a serious leak. Immediately go into action as instructed earlier.

SOME POINTS TO REMEMBER

- Learn to recognize the odor of Propane Gas. Your local Propane Gas Dealer can give you a "Scratch and Sniff" pamphlet. Use it to find out what the propane odor smells like. If you suspect that your Propane Gas has a weak or abnormal odor, call your Propane Gas Dealer.
- If you are not qualified, do not light pilot lights, perform service, or make adjustments to appliances on the Propane Gas system. If you are qualified, consciously think about the odor of Propane Gas prior to and while lighting pilot lights or performing service or making adjustments.
- Sometimes a basement or a closed-up house has a musty smell that can cover up the Propane Gas odor. Do not try to light pilot lights, perform service, or make adjustments in an area where the conditions are such that you may not detect the odor if there has been a leak of Propane Gas.
- Odor fade, due to oxidation by rust or adsorption on walls of new cylinders and tanks, is possible. Therefore, people should be particularly alert and careful when new tanks or cylinders are placed in service. Odor fade can occur in new tanks, or reinstalled old tanks, if they are filled and allowed to set too long before refilling. Cylinders and tanks which have been out of service for a time may develop internal rust which will cause odor fade. If such conditions are suspected to exist, a periodic sniff test of the gas is advisable. If you have any question about the gas odor, call your Propane Gas Dealer. A periodic sniff test of the Propane Gas is a good safety measure under any condition.
- If, at any time, you do not smell the Propane Gas odorant and you think you should, assume you have a leak. Then take the same immediate action recommended above for the occasion when you do detect the odorized Propane Gas.
- If you experience a complete "gas out," (the container is under no vapor pressure), turn the tank valve off immediately. If the container valve is left on, the container may draw in some air through openings such as pilot light orifices. If this occurs, some new internal rusting could occur. If the valve is left open, then treat the container as a new tank. Always be sure your container is under vapor pressure by turning it off at the container before it goes completely empty or having it refilled before it is completely empty.

INTRODUCTION

Instructions to Installer

1. Installer must leave instruction manual with owner after installation.
2. Installer must have owner fill out and mail warranty card supplied with unvented room heater.
3. Installer should show owner how to start and operate unvented room heater.

Always consult your local Building Department regarding regulations, codes or ordinances which apply to the installation of an unvented room heater.

This appliance may be installed in an aftermarket* permanently located, manufactured (mobile) home, where not prohibited by state or local codes.

*Aftermarket: Completion of sale, not for purpose of resale, from the manufacturer.

Well Head Gas Installations

Some natural gas utilities use "well head" gas. This may affect the Btu output of the unit and promote sooting. Units shall not be converted to use well head gas.

This appliance is only for use with the type of gas indicated on the rating plate. This appliance is not convertible for use with other gases.

General Information

This BF-10W, BF-20W and BF-30W are design certified in accordance with American National Standards Institute Z21.11.2-2016 by the Canadian Standards Association as an Unvented Room Heater and should be installed according to these instructions.

Any alteration of the original design, installed other than as shown in these instructions or use with a type of gas not shown on the rating plate is the responsibility of the person and company making the change.

WARNING

This appliance is equipped for (natural gas or propane gas). Field conversion is not permitted.

Important

All correspondence should refer to complete Model Number, Serial Number and type of gas.

Qualified Installing Agency

Installation and replacement of gas piping, gas utilization equipment or accessories and repair and servicing of equipment shall be performed only by a qualified agency. The term "qualified agency" means any individual, firm, corporation, or company that either in person or through a representative is engaged in and is responsible for (a) the installation, testing, or replacement of gas piping or (b) the connection, installation, testing, repair, or servicing of equipment; that is experienced in such work; that is familiar with all precautions required, and that has complied with all the requirements of the authority having jurisdiction.

Commonwealth of Massachusetts: The installation must be made by a licensed plumber or gas fitter in the Commonwealth of Massachusetts.

Sellers of unvented propane or natural gas-fired supplemental room heaters shall provide to each purchaser a copy of 527 CMR 30 upon sale of the unit.

In the Commonwealth of Massachusetts, unvented propane and natural gas-fired space heaters shall be prohibited in bedrooms and bathrooms.

The installation must conform with local codes or, in the absence of local codes, with the National Fuel Gas Code, ANSI Z223.1/NFPA54.*

*Available from the American National Standards Institute, Inc., 11 West 42nd St., New York, N.Y. 10036.

High Altitudes

For altitudes/elevations above 2,000 feet (610m), ratings should be reduced at the rate of 4 percent for each 1,000 (305m) feet above sea level. Contact the manufacturer or your gas company before changing spud/orifice size.

SPECIFICATIONS

Model	BF-10W	BF-20W	BF-30W
Input Btu/HR (KW/H)(Propane)	10,000 (2.9)	20,000 (5.8)	30,000 (8.8)
Input Btu/HR (KW/H)(Natural)	10,000 (2.9)	20,000 (5.8)	30,000 (8.8)
Height	22" (559mm)	22" (559mm)	22" (559mm)
Width	18" (457mm)	18" (457mm)	24 1/8" (536mm)
Depth	6 1/2" (165mm)	6 1/2" (165mm)	6 1/2" (165mm)
Gas Inlet	3/8" (10mm)	3/8" (10mm)	3/8" (10mm)
Accessories			
Blower	SRB-18TW	SRB-18TW	SRB-30TW
Floor Stand	SRS-18W*	SRS-18W	SRS-30W

*SRS-18W floor stand can not be used in a bedroom installation.

BF-10 must be wall mounted in a bedroom installation.

The bedroom must be an unconfined space. ANSI Z223.1/NFPA 54 defines an unconfined space as "a space whose volume is not less than 50 cubic feet per 1,000 Btu per hour (4.8m³ per kw) of the aggregate input rating of all appliances installed in that space."

WATER VAPOR: A BY-PRODUCT OF UNVENTED ROOM HEATERS

Water vapor is a by-product of gas combustion. An unvented room heater produces approximately one (1) ounce (30ml) of water for every 1,000 Btu (.3KW's) of gas input per hour.

Unvented room heaters must be used as supplemental heat (a room) rather than a primary heat source (an entire house). In most supplemental heat applications, the water vapor does not create a problem. In most applications, the water vapor enhances the low humidity atmosphere experienced during cold weather.

The following steps will help insure that water vapor does not become a problem.

1. Be sure the heater is sized properly for the application, including ample combustion air and circulation air.
2. If high humidity is experienced, a dehumidifier may be used to help lower the water vapor content of the air.
3. Do not use an unvented room heater as the primary heat source (an entire house).

PROVISIONS FOR ADEQUATE COMBUSTION & VENTILATION AIR

This heater shall not be installed in a confined space or unusually tight construction unless provisions are provided for adequate combustion and ventilation air.

A confined space is an area with volume less than 50 cubic feet per 1,000 Btuh of the combined input rates of all appliances drawing combustion air from that space. Small areas such as equipment rooms are confined spaces. Furnaces installed in a confined space which supply heated air to areas outside the space must draw return air from outside the space through tightly sealed return air ducts. A confined space must have 2 openings into the space for combustion air. One opening must be within 12 inches of the ceiling and the other must be within 12 inches of the floor. The required sizing of these openings is determined by whether inside or outside air is used to support combustion, the method by which the air is brought to the space (vertical or horizontal duct) and by the total input rate of all appliances in the space.

The following example is for determining the volume of a typical area in which the BF-20W may be located and for determining if this area fits the definition of an unconfined space.

The input of the BF-20W is 20,000 Btu per hour. Based on the 50 cubic feet per 1,000 Btu per hour formula, the minimum area that is an unconfined space for installation of the BF-20W is 1,000 cubic feet, 50 cubic feet x 20 = 1,000 cubic feet. To determine the cubic feet of the area in which the BF-20W is to be installed, measure the length, width and height of the area. Example: The area measures 16 feet in length, 8 feet in width and 8 feet in height, the area is 1,024 cubic feet. The BF-20W can be installed in this unconfined space with no requirement to provide additional combustion and ventilation air.

WARNING

If the area in which the heater may be operated is smaller than that defined as an unconfined space or if the building is of unusually tight construction, provide adequate combustion and ventilation air by one of the methods described in the National Fuel Gas Code, ANSI Z223.1/NFPA 54, Air for Combustion and Ventilation, or applicable local codes.

Unusually Tight Construction

The air that leaks around doors and windows may provide enough fresh air for combustion and ventilation. However, in buildings of unusually tight construction, you must provide additional fresh air.

Unusually tight construction is defined as construction where:

- a. Walls and ceilings exposed to the outside atmosphere have a continuous water vapor retarder with a rating of one perm or less with openings gasketed or sealed, and
- b. Weatherstripping has been added on openable windows and doors, and
- c. Caulking or sealants are applied to areas such as joints around window and door frames, between sole plates and floors, between wall-ceiling joints, between wall panels, at penetrations for plumbing, electrical, and gas lines, and at other openings.

If the heater is installed in a building of unusually tight construction, adequate air for combustion, ventilation and dilution of flue gases shall be provided in accordance with ANSI Z223.1/NFPA54.

WARNING

This heater shall not be installed in a room or space unless the required volume of indoor combustion air is provided by the method described in the National Fuel Gas Code, ANSI Z223.1/NFPA 54, the International Fuel Gas Code, or applicable local codes."

GAS SUPPLY

The gas line can be routed either through the floor or wall. The gas line opening should be made at this time. Location of the opening will be determined by the position of floor joists and the valve and union used for servicing.

Gas Supply

Check all local codes for requirements, especially for the size and type of gas supply line required.

RECOMMENDED GAS PIPE DIAMETER				
Pipe Length	Schedule 40 Pipe Inside Diameter		Tubing, Type L Outside Diameter	
	Natural	Propane	Natural	Propane
0-10 feet 0-3 meters	1/2" 12.7mm	3/8" 9.5mm	1/2" 12.7mm	3/8" 9.5mm
10-40 feet 4-12 meters	1/2" 12.7mm	1/2" 12.7mm	5/8" 15.9mm	1/2" 12.7mm
40-100 feet 13-30 meters	1/2" 12.7mm	1/2" 12.7mm	3/4" 19mm	1/2" 12.7mm
100-150 feet 31-46 meters	3/4" 19mm	1/2" 12.7mm	7/8" 22.2mm	3/4" 19mm

NOTICE: Never use plastic pipe. Check to confirm whether your local codes allow copper tubing or galvanized.

NOTICE: Since some municipalities have additional local codes, it is always best to consult your local authority and installation code.

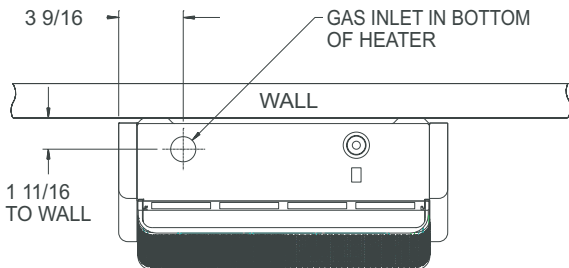

Figure 1

Installing a New Main Gas Shut-Off

Each appliance should have its own manual gas shut-off.

A manual main gas shut-off should be located in the vicinity of the unit. Where none exists, or where its size or location is not adequate, contact your local authorized installer for installation or relocation.

Compounds used on threaded joints of gas piping shall be resistant to the action of liquefied petroleum gases. The gas lines must be checked for leaks by the installer. This should be done with a soap solution watching for bubbles on all exposed connections, and if unexposed, a pressure test should be made.

Never use an exposed flame to check for leaks. Appliance must be disconnected from piping at inlet of control valve and pipe capped or plugged for pressure test. Never pressure test with appliance connected; control valve will sustain damage!

A gas valve and ground joint union should be installed in the gas line upstream of the gas control to aid in servicing. It is required by the National Fuel Gas Code that a drip line be installed near the gas inlet. This should consist of a vertical length of pipe tee connected into the gas line that is capped on the bottom in which condensation and foreign particles may collect.

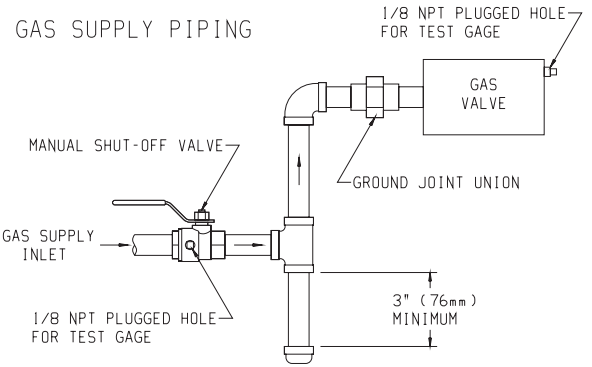

Figure 2

Method of Installing a Tee Fitting Sediment Trap - See Figure 2
The use of the following gas connectors is recommended:

- ANS Z21.24 Appliance Connectors of Corrugated Metal Tubing and Fittings
- ANS Z21.45 Assembled Flexible Appliance Connectors of Other Than All-Metal Construction

The above connectors may be used if acceptable by the authority having jurisdiction. The Commonwealth of Massachusetts requires that a flexible appliance connector cannot exceed three feet in length.

Pressure Testing of the Gas Supply System

1. To check the inlet pressure to the gas valve, a 1/8" (3mm) N.P.T. plugged tapping, accessible for test gauge connection, must be placed immediately upstream of the gas supply connection to the appliance.
2. The appliance and its appliance main gas valve must be disconnected from the gas supply piping system during any pressure testing of that system at test pressures in excess of 1/2 psig (3.5 kPa).
3. The appliance must be isolated from the gas supply piping system by closing its equipment shutoff valve during any pressure testing of the gas supply piping system at test pressures equal to or less than 1/2 psig (3.5 kPa).

Attention! If one of the above procedures results in pressures in excess of 1/2 psig (14" w.c.) (3.5 kPa) on the appliance gas valve, it will result in a hazardous condition.

Checking Manifold Pressure

Natural Gas will have a manifold pressure of approximately 3.5" w.c. (.87kPa) at the pressure regulator outlet with the inlet pressure to the pressure regulator from a minimum of 5.0" w.c. (1.245kPa) for the purpose of input adjustment to a maximum of 10.5" w.c. (2.615kPa). Propane Gas will have a manifold pressure approximately 10.0" w.c. (2.49kPa) at the pressure regulator outlet with the inlet pressure to the pressure regulator from a minimum of 11.0" w.c. (2.739kPa) for the purpose of input adjustment to a maximum of 13.0" w.c. (3.237kPa).

A test gage connection is located downstream of the gas appliance pressure regulator for measuring gas pressure. The connection is a 1/8 inch (3mm) N.P.T. plugged tapping.

CLEARANCES

When facing the front of the appliance the following minimum clearances to combustible construction must be maintained. Do not install in alcove or closet.

	BF-10W/BF-20W	BF-30W
Left side	5" (127mm)	8" (203mm)
Right side	5" (127mm)	8" (203mm)
Rear wall	0" (0mm)	0" (0mm)
Ceiling	36" (914mm)	36" (914mm)
Minimum vertical clearance from a projections above the appliance (shelves, window sills, etc.)	36" (914mm)	36" (914mm)
Floor (top surface of carpeting, tile, etc.)	2" (51mm)	2" (51mm)

Provide adequate clearances around air openings.

Adequate accessibility clearances for purposes of servicing and proper operation must be provided.

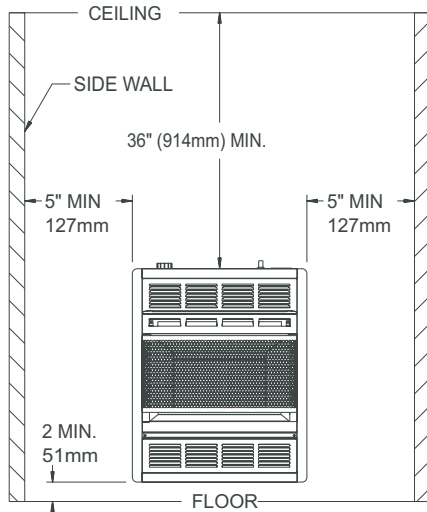

BF-10W and BF-20W
Figure 3

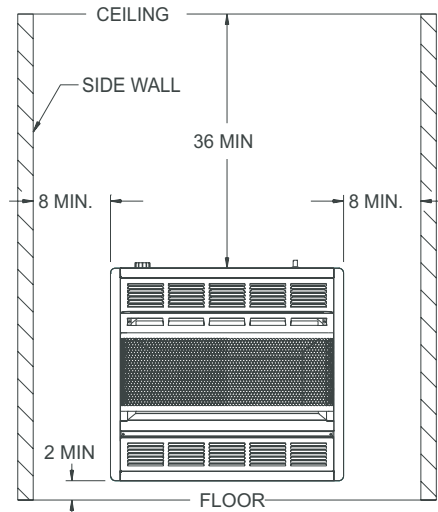

BF-30W
Figure 4

OPTIONAL FLOOR STAND INSTALLATION

SRS-18W* and SRS-30W Floor Stand Installation

1. Align clearance holes on floor stand with screw holes on bottom of heater, as shown in **Figure 5**.
2. Attach floor stand to heater with (4) screws provided with floor stand.
3. Connect the gas line.
*SRS-18W floor stand can not be used in a bedroom installation.
BF-10W must be wall mounted in a bedroom installation.

Installation on Rugs and Tile

If this appliance is installed directly on carpeting, tile or other combustible material, other than wood flooring, the appliance shall be installed on the optional SRS-18W or SRS-30W floor stand.

The floor stand referred to in this section does not mean the fire-proof base as used on wood stoves. The protection is for rugs that are extremely thick and light colored tile.

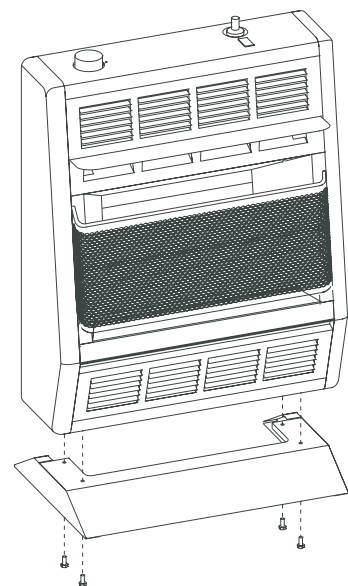

Figure 5

WALL MOUNT INSTALLATION

Refer to **Figures 6 and 7** for measurements in order to locate (4) mounting holes on wall. **Figures 6 and 7** are the front views of the heater.

1. Remove lower louver from casing assembly (2 screws).
2. Remove reflector from casing assembly (2 screws).
3. Remove upper louver from casing assembly (2 screws).

On Solid Wall

1. After locating mounting holes, attach (4) #10 x 1" (25mm) screws provided into the wall. Do not completely tighten screwheads to the wall, leave a 1/8" (3mm) gap between screwheads and wall.
2. Mount heater onto the (4) screwheads and complete tightening screwheads into the wall.
Attention! Use the following steps to properly align the upper louver and the reflector with the heat shield.
 - a. When replacing upper louver, be sure the bottom lip of upper louver goes behind the heat shield.
 - b. When replacing reflector, be sure the top lip of reflector goes in front of the heat shield.
3. Connect the gas line.

BF-10 and BF-20

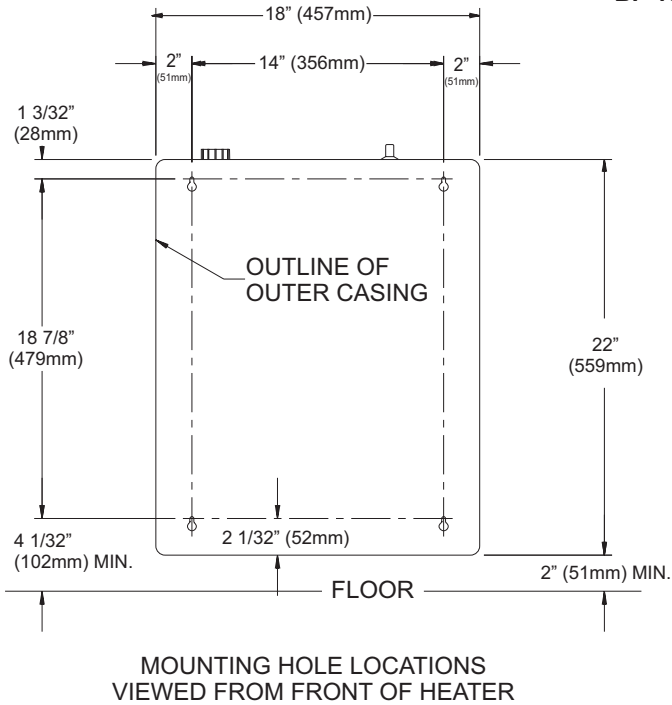
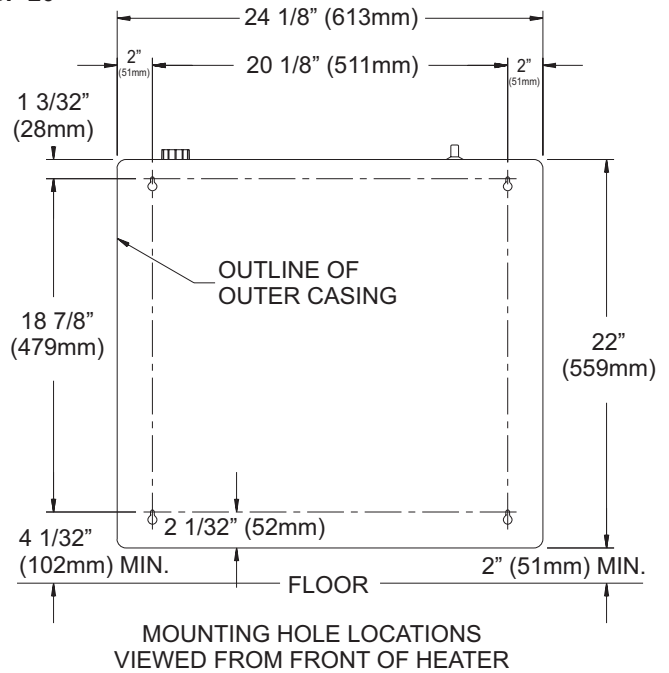

Figure 6



BF-30
Figure 7

On Sheet Rock Wall

1. After locating mounting holes, drill (4) 5/16" (8mm) diameter holes into the wall.
2. Insert (4) plastic expansion anchors provided into the holes.
3. Tighten (4) #10 x 1" (25mm) screws provided into the plastic expansion anchors. Do not completely tighten screwheads to the plastic expansion anchors, leave a 1/8" (3mm) gap between screwheads and plastic expansion anchors.
4. Mount heater onto the (4) screwheads and complete tightening the screwheads to the plastic expansion anchors.
Attention! Use the following steps to properly align the upper louver and the reflector with the heat shield.
 - a. When replacing upper louver, be sure the bottom lip of upper louver goes behind the heat shield.
 - b. When replacing reflector, be sure the top lip of reflector goes in front of the heat shield.
5. Connect the gas line.

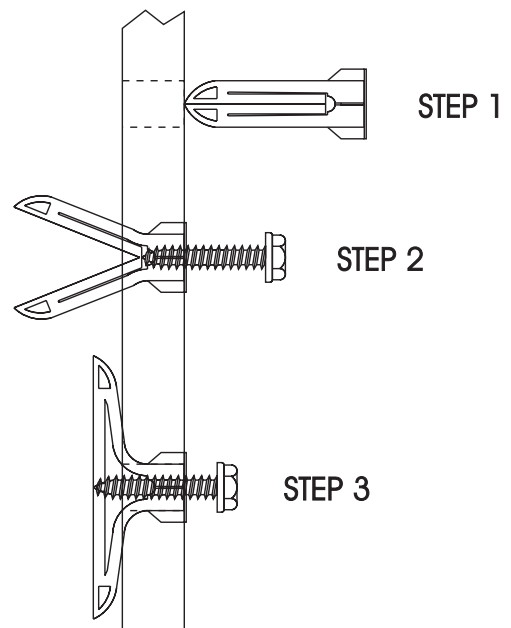

Figure 8

LIGHTING INSTRUCTIONS





FOR YOUR SAFETY READ BEFORE LIGHTING

⚠ WARNING

If you do not follow these instructions exactly, a fire or explosion may result causing property damage, personal injury or loss of life.

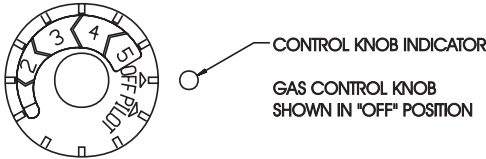
- A. This appliance has a pilot which must be lighted by hand. When lighting the pilot, follow these instructions exactly.
- B. BEFORE LIGHTING smell all around the appliance area for gas. Be sure to smell next to the floor because some gas is heavier than air and will settle on the floor.
- WHAT TO DO IF YOU SMELL GAS
- Do not try to light any appliance.
 - Do not touch any electrical switch; do not use any phone in your building.
 - Immediately call your gas supplier from a neighbor's phone. Follow the gas supplier's instructions.
 - If you cannot reach your gas supplier, call the fire department.
- C. Use only your hand to push in or turn the gas control knob. Never use tools. If the knob will not push in or turn by hand, don't try to repair it; call a qualified service technician. Force or attempted repair may result in a fire or explosion.
- D. Do not use this appliance if any part has been under water. Immediately call a qualified service technician to inspect the appliance and to replace any part of the control system and any gas control which has been under water.

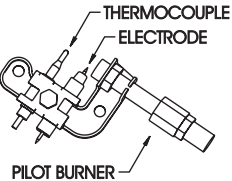
LIGHTING INSTRUCTIONS

1. STOP! Read the safety information above.
 2. Set thermostat (gas control knob) to lowest setting.
 3. Turn off all electric power to the appliance (if applicable).
 4. Push in gas control knob slightly and turn clockwise  to "OFF". Do not force.
- 
5. Wait ten (10) minutes to clear out any gas. Then smell for gas, including near the floor. If you smell gas, STOP! Follow "B" in the safety information above. If you don't smell gas, go to the next step.
 6. Find pilot - the pilot is attached at the bottom of the burner assembly.
 7. Turn gas control knob counterclockwise  to "PILOT."
 8. Push in gas control knob all the way and hold in. Repeatedly push the piezo ignitor button until pilot is lit (or use a match to light pilot). Continue to hold the control knob in for about one (1) minute after the pilot is lit. Release knob and it will pop back up. Pilot should remain lit. If it goes out, repeat steps 4 through 8.
- 
9. Attention! Gas control has an INTERLOCK latching device. When the pilot is initially lit and the safety magnet is energized (pilot stays "ON") the INTERLOCK latching device becomes operative. If the gas control is turned to the "OFF" position or gas flow to the appliance is shut off, the pilot cannot be relighted until the safety magnet is de-energized (approximately 60 seconds). There will be an audible "click" when the safety magnet in the gas control is de-energized. Pilot can now be relighted. Repeat steps 4 through 8.
 10. Turn gas control knob counterclockwise  to "HI".
 11. Turn on all electric power to appliance (if applicable).
 12. Set thermostat (gas control knob) to desired setting from "HI" to "LO".

TO TURN OFF GAS TO APPLIANCE

1. Set thermostat (gas control knob) to lowest setting.
2. Turn off all electric power to appliance if service is to be performed (if applicable).
3. Push in gas control knob slightly and turn clockwise  to "OFF". Do not force.

MAIN BURNER FLAME CHARACTERISTICS

Piezo Pilot Ignitor Instructions

Depressing the ignitor button completely causes a spark to occur at the pilot.

To light the pilot, it is important that the electrode be 1/8" (3mm) from the pilot. The spark must occur at the point the pilot flame hits the thermocouple.

On a new installation with air in the gas line, it is suggested that a match be used. The match will light the pilot faster than the piezo under this condition.

There will be a short blue inner flame with a much larger, lighter blue, secondary flame. The burner flame may have a small yellow tip when hot. Dust in the combustion air will produce an orange or red flame. Do not mistake the orange or red flame for an improper yellow flame. Clean main burner by applying compressed air into ports and throat of main burner.

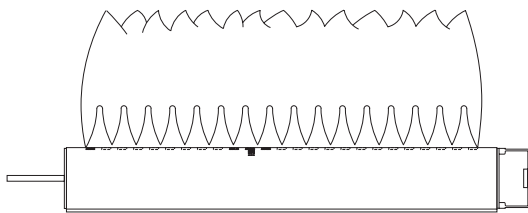

Figure 9

Attention: BF-10W, Natural or Propane Gas has a front and rear air shutter.

BF-20W, Propane Gas only has a front air shutter.

BF-30W, Propane Gas only has a front air shutter.

Air Shutter Adjustment - See Figure 10

The air shutter on main burner is factory set at a 3/32" opening. If yellow flames occur on main burner loosen 1/4" screw on air shutter in order to increase air shutter opening. The slot on air shutter allows the air opening to be increased or decreased. Tighten 1/4" screw on air shutter after air shutter adjustment has been completed.

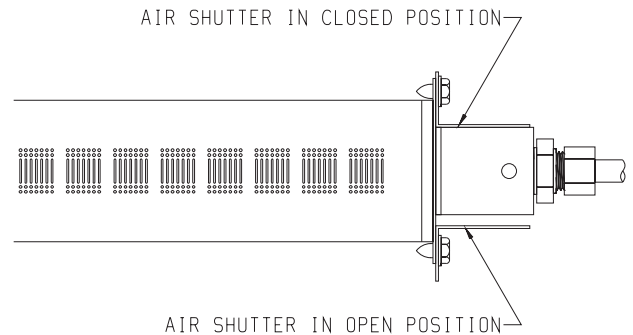

PARTIAL VIEW FROM TOP OF BURNER

Figure 10

Cleaning Main Burner Orifice and Main Burner

1. Turn OFF gas supply to the heater.
2. Turn OFF electric supply to the heater if optional blower, SRB-18TW or SRB-30TW is installed in heater.
3. Remove lower louver from casing assembly (2 screws).
4. Remove reflector from casing assembly (2 screws).
5. Inspect interior of casing assembly for accumulation of dust, lint or spider webs. If necessary, clean interior of casing assembly with a vacuum cleaner or apply air pressure. Do not damage any components within casing assembly when you are cleaning.
6. Remove main burner orifice from orifice holder.
7. Apply air pressure through main burner orifice and orifice holder to remove dust, lint or spider webs.
8. Apply air pressure into main burner to remove dust, lint or spider webs.
9. As parts are being replaced in reverse order, check for gas leaks at all gas connections before lower louver is replaced onto casing assembly.

IMPORTANT SOOT PREVENTION STEPS

IMPORTANT NOTICE

INSTALLER - SERVICE PERSON - HOMEOWNER

SOOT MAY BE CREATED IF THE FOLLOWING DIRECTIONS ARE NOT FOLLOWED

A vent-free heater draws room air to support combustion. Lightweight particles suspended in the air – including dust, carpet fibers, candle or tobacco smoke, and pet hair – will be drawn toward the heater. These can lead to soot build-up on the heater, and even walls of the room. To prevent malfunctions and sooting, have your dealer inspect and clean each year – before the heating season. If you have pets or excessive dust, more frequent cleaning may be necessary. See main burner flame characteristics section in this manual.

1. Ensure burner, venturi, and air shutter are free of dirt, lint, animal hair (i.e. cat and dog) or anything that may block the needed air flow.

2. Do not use scented air fresheners or candles while the heater is in operation. They produce residue which may cause soot.
3. Annual inspection and cleaning by your dealer or a qualified service technician is recommended to prevent malfunction and/or sooting.

⚠ WARNING

Do not allow fans to blow directly into or at the fireplace. Avoid any drafts that alter burner flame patterns. Avoid any drafts that alter burner flame patterns. Pay particular attention to ceiling fans and exhaust fans.

PILOT FLAME CHARACTERISTICS

Check the pilot flame periodically to ensure it is burning correctly. The correct flame will be blue and will extend beyond the thermocouple. The flame will surround the thermocouple just below the tip. A slight yellow flame may occur where the pilot flame and main burner flame meet.

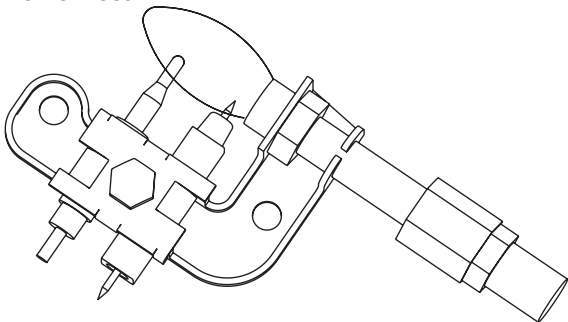

Figure 11

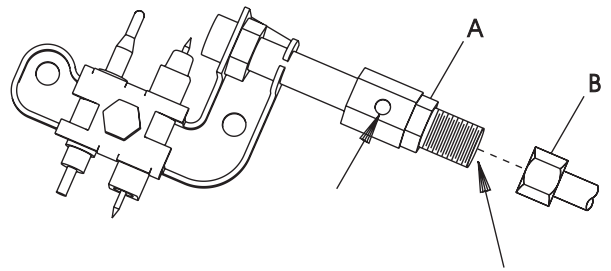

Figure 12

⚠ WARNING

Never use needles, wires, or similar cylindrical objects to clean the pilot to avoid damaging the calibrated ruby that controls the gas flow.

Oxygen Depletion Sensor Pilot - See Figure 12

When the pilot has a large yellow tip flame, clean the Oxygen Depletion Sensor as follows:

1. Remove pilot from main burner assembly, see "Appliance Maintenance", Page 13.
2. Apply air pressure through the holes in the pilot indicated by the arrows in **Figure 12**. This will blow out foreign materials such as dust, lint and spider webs.

THERMOSTAT OPERATION

To ignite main burner, rotate gas control knob counterclockwise toward HI setting. To shut down main burner, rotate gas control knob clockwise toward LO setting.

BF-10W

The gas control has an input of 10,000 Btu/HR (2.9 KW/H). The hydraulic thermostat bulb is located at the casing assembly bottom.

BF-20W

The gas control modulates from a minimum input of 8,500 Btu/HR (2.5 KW/H) (LO setting) to a maximum input of 20,000 Btu/HR (5.9 KW/H) for Propane Gas (HI setting) or 18,000 Btu/HR (5.3 KW/H) for Natural Gas (HI setting). The hydraulic thermostat bulb which is located at the casing assembly bottom adjusts the main burner flame between minimum input and maximum input.

BF-30W

The gas control modulates from a minimum input of 8,500 Btu/HR (2.5 KW/H) (LO setting) to a maximum input of 30,000 Btu/HR (8.8 KW/H) (HI setting). The hydraulic thermostat bulb which is located at the casing assembly bottom adjusts the main burner flame between minimum input and maximum input.

NOTE: When the hydraulic thermostat bulb is "satisfied" the main burner flame will shut "OFF" with the pilot flame remaining "ON".

The LO and HI setting has temperature range of approximately 55°F (12.78°C) to 90°F (32.22°C), respectively. This is the temperature at the hydraulic thermostat bulb not the room temperature. The owner is advised to determine the particular heat setting that is desired for comfort, as heating requirements are different for every owner.

Attention: If the owner does not want the main burner to ignite and turns the gas control knob to the Lo setting, the main burner will still ignite if the temperature at the hydraulic thermostat bulb drops to 55°F (12.78°C).

If no heat is desired, turn the gas control knob to the PILOT position.

APPLIANCE MAINTENANCE

WARNING

Do not operate unvented room heater without grill attached to reflector.

To Remove Pilot From Main Burner Assembly

1. Turn OFF gas supply to the heater.
2. Turn OFF electrical supply to the heater if optional blower, SRB-18TW or SRB-30TW is installed in heater.
3. Remove lower louver from casing assembly (2 screws).
4. Remove reflector from casing assembly (2 screws).
5. Disconnect pilot tubing from pilot. **See Figure 12**, Page 12. Grasp nut A with a wrench when removing nut B with a second wrench.
6. Remove pilot from pilot bracket (2 nuts).
7. As parts are being replaced in reverse order, check for gas leaks at all gas connections before lower louver is replaced onto casing assembly.

To Remove Main Burner Orifice From Main Burner Assembly

1. Turn off gas supply to the heater.
2. Turn off electrical supply to the heater if optional blower, SRB-18TW or SRB-30TW is installed in heater.
3. Remove lower louver from casing assembly (2 screws).
4. Remove reflector from casing assembly (2 screws).
5. Disconnect supply tubing from orifice holder.
6. Remove orifice holder from venturi of main burner assembly.
7. Remove main burner orifice from orifice holder.
8. As parts are being replaced in reverse order, check for gas leaks at all gas connections before lower louver is replaced onto casing assembly.

To Remove Gas Valve From Casing Assembly

1. Turn OFF gas supply to the heater.
2. Turn OFF electrical supply to the heater if optional blower, SRB-18TW or SRB-30TW is installed in heater.
3. Remove lower louver from casing assembly (2 screws).
4. Remove reflector from casing assembly (2 screws).
5. Remove upper louver from casing assembly (2 screws).
6. If installed, remove optional blower assembly (4 screws).
7. Disconnect inlet supply tubing, outlet supply tubing, pilot supply tubing and thermocouple lead from gas valve.
8. If heater is attached to wall, disconnect gas supply line from inlet regulator.
9. Remove heater from wall.
10. Remove gas valve bracket from casing assembly (4 screws to be removed are located on casing assembly back).
11. Remove hydraulic thermostat bulb from thermostat bulb clip located at casing assembly bottom.
12. Remove gas valve from gas valve bracket.
13. As parts are being replaced in reverse order, check for gas leaks at all gas connections before upper louver, reflector and lower louver are replaced onto casing assembly.

To Remove Main Burner From Casing Assembly

1. Turn OFF gas supply to the heater.
2. Turn OFF electrical supply to the heater if optional blower, SRB-18TW or SRB-30TW is installed in heater.
3. Remove lower louver from casing assembly (2 screws).
4. Remove reflector from casing assembly (2 screws).
5. Disconnect supply tubing from orifice holder.
6. Remove main burner assembly from casing assembly (2 screws).
7. Remove air shutter(s) from main burner. BF-10W Natural and Propane has two (2) air shutters, BF-20W Propane has one (1) air shutter and BF-30W Propane has one (1) air shutter. Attach air shutter(s) to new main burner assembly.
8. As parts are being replaced in reverse order, check for gas leaks at all gas connections before lower louver is replaced onto casing assembly.

TROUBLESHOOTING

SYMPTOMS - POSSIBLE CAUSES AND CORRECTIONS

- 1. Spark electrode does not produce spark.**
 - a. Spark electrode broken - replace.
 - b. Ignitor wire may not be attached to spark electrode - attach.
 - c. Ignitor wire damaged - replace.
 - d. Piezo ignitor defective - replace.
- 2. Spark electrode produces spark but pilot does not light.**
 - a. No gas to heater - turn on gas.
 - b. PILOT position not properly aligned - turn gas control knob to PILOT position and depress.
 - c. Pilot is blocked from spider web or dirt - clean pilot, see **Figure 12**, Page 12.
- 3. Pilot flame does not stay "ON" when control knob is released.**
 - a. Control knob in PILOT position not completely depressed or held in long enough.
 - b. INTERLOCK latching device is operative - see "Lighting Instructions," Page 10, Step 9.
- c. Thermocouple lead not tightened into gas control - tighten thermocouple lead.
 - d. Pilot flame not surrounding thermocouple - clean pilot, see **Figure 12**, Page 12.
 - e. Inlet gas pressure too low, contact gas supplier.
 - f. Thermocouple defective - replace pilot.
 - g. Gas control defective - replace.
- 4. Main burner does not ignite.**
 - a. Main burner orifice is blocked - clean, see "Main Burner Flame Characteristics," Page 11.
 - b. Inlet gas pressure too low, contact gas supplier.
- 5. Heater keeps shutting "OFF" during normal operation.**
 - a. Pilot is blocked - clean pilot, **See Figure 12**, Page 12.
 - b. Inlet gas pressure too low, contact gas supplier

PARTS LIST

PLEASE NOTE: When ordering parts, it is very important that part number and description of part coincide.

Index No.	Part No.	Description
1	39818	CASING SIDE ASSEMBLY - LEFT (BF-10W)
1	39819	CASING SIDE ASSEMBLY - LEFT (BF-20W, BF-30W)
2	39822	CASING BACK (BF-10W, BF-20W)
2	39824	CASING BACK (BF-30W)
3	R-2313	PIEZO IGNITOR
4	11231	FAN CONTROL BRACKET (BF-10W)
5	39820	CASING SIDE ASSEMBLY - RIGHT
6	R-1992	BULB CLIP
7	39825	CASING LOUVER (BF-10W, BF-20W)
7	39826	CASING LOUVER (BF-30W)
8	SR-077	HEAT SHIELD (BF-10W, BF-20W)
8	SR-018	HEAT SHIELD (BF-30W)
9	SR-075	REFLECTOR SHIELD REAR (BF-10W, BF-20W)
9	SR-016	REFLECTOR SHIELD REAR (BF-30W)
10	10478	REAR SHIELD (BF-10W, BF-20W)
10	10420	REAR SHIELD (BF-30W)
11	35956	REFLECTOR ASSEMBLY (BF-10W, BF-20W) INCLUDES 9 & 10
11	35957	REFLECTOR ASSEMBLY (BF-30W) INCLUDES 9 & 10
13	39831	SCREEN (BF-10W, BF-20W)
13	39832	SCREEN (BF-30W)
14	40466	FLAME SHIELD (BF-10W, BF-20W)
14	39840	FLAME SHIELD (BF-30W)
15	R-2784	INLET REGULATOR - NATURAL
15	R-2480	INLET REGULATOR - PROPANE
16	10753	INLET REGULATOR BRACKET
17	12442	TUBING - GAS VALVE TO BURNER (BF-10W, BF-20W)
17	12443	TUBING - GAS VALVE TO BURNER (BF-30W)
18	12437	TUBING - INLET REGULATOR TO GAS VALVE
19	*R-6563	GAS VALVE (NATURAL & PROPANE)
20	SR-113	VALVE BRACKET
21	10460	BURNER BRACKET - LEFT
22	40465	BURNER (BF-10W, BF-20W)
22	39834	BURNER (BF-30W)
23	10424	AIR SHUTTER REAR (BF-10W ONLY)
24	10461	BURNER BRACKET - RIGHT
25	P-214	MAIN BURNER ORIFICE (BF-10W NATURAL)

Index No.	Part No.	Description
25	P-193	MAIN BURNER ORIFICE (BF-10W PROPANE)
25	P-252	MAIN BURNER ORIFICE (BF-20W NATURAL)
25	P-182	MAIN BURNER ORIFICE (BF-20W PROPANE)
25	P-211	MAIN BURNER ORIFICE (BF-30W NATURAL)
25	P-185	MAIN BURNER ORIFICE (BF-30W PROPANE)
26	P-212	ORIFICE HOLDER
27	10424	AIR SHUTTER FRONT (BF-10W NATURAL AND PROPANE) (BF-20W & BF-30W PROPANE ONLY)
28	39842	TUBING - GAS VALVE TO PILOT (BF-10W, BF-20W)
28	39843	TUBING - GAS VALVE TO PILOT (BF-30W)
29	R6306	PILOT ASSEMBLY (NATURAL ONLY) (INCLUDES 30 & 31)
29	R-6308	PILOT ASSEMBLY (PROPANE ONLY) (INCLUDES 30 & 31)
30	R-6310	PILOT THERMOCOUPLE
31	R-6309	SPARK IGNITOR
32	R-2390	IGNITOR WIRE
33	SRS-18W	OPTIONAL FLOOR STAND KIT (BF-10W, BF-20W)
33	SRS-30W	OPTIONAL FLOOR STAND KIT (BF-30W)
34	SRB-18TW	OPTIONAL BLOWER KIT (BF-10W, BF-20W) (INCLUDES 35 THROUGH 42)
34	SRB-30TW	OPTIONAL BLOWER KIT (BF-30W) (INCLUDES 35 THROUGH 42)
35	R-1454	BRASS BUSHING (4 REQUIRED)
36	R-1499	RUBBER GROMMET (4 REQUIRED)
37	39873	BLOWER PAN (BF-10W, BF-20W)
37	39874	BLOWER PAN (BF-30W)
38	R-2099	CORD SET ASSEMBLY
39	R-1468	BUSHING - HEYCO #SR5KN4
40	R-2395	WIRE ASSEMBLY
41	R-2503	FAN CONTROL
42	R-2396	BLOWER (INCLUDES MOTOR, FAN, AND FAN HOUSING)
N/S	39983	BLOWER HARDWARE PACKAGE
N/S	SR-216	HARDWARE PACKAGE
N/S	R-1976	MIN. RATE SCREW NATURAL 1.60
N/S	R-1977	MIN. RATE SCREW PROPANE 1.00

*Must also purchase Min. Rate Screw.

USE ONLY MANUFACTURER'S REPLACEMENT PARTS. USE OF ANY OTHER PARTS COULD CAUSE INJURY OR DEATH.

PARTS VIEW

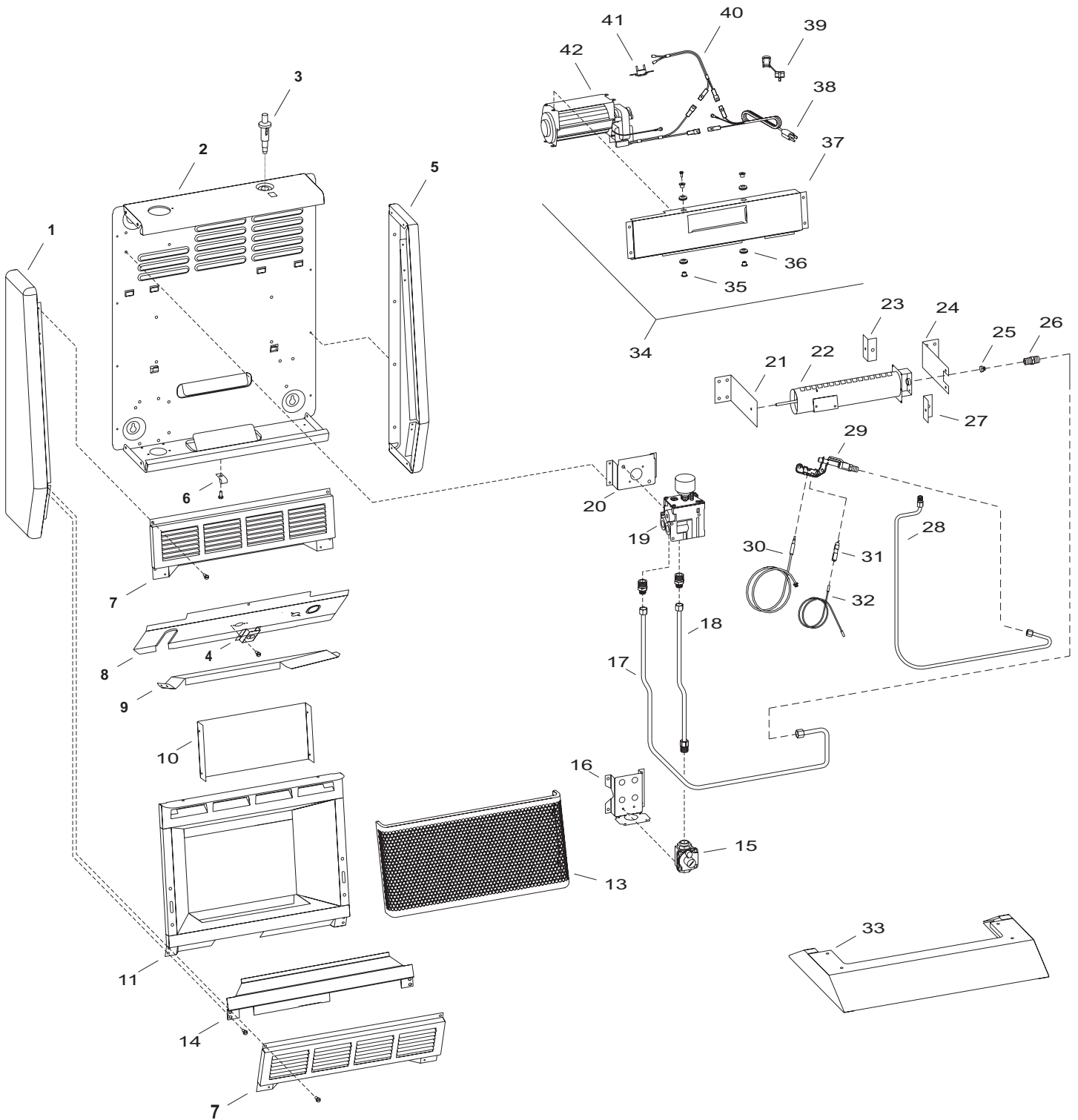

OPTIONAL BLOWER INSTALLATION INSTRUCTIONS

SRB-18TW and SRB-30TW for Unvented Room Heaters BF-10W, BF-20W and BF-30W

INSTALLING OPTIONAL BLOWER SRB-18TW OR SRB-30TW

If heater is installed onto the wall, in order to install the optional blower, the heater must be removed from the wall. If heater is installed on SRS-18W or SRS-30W optional floor stand there is adequate access area available to install the optional blower.

1. Turn "OFF" gas supply to the heater.
2. Remove lower louver from casing assembly (2 screws).
3. Remove reflector from casing assembly (2 screws).
4. Remove upper louver from casing assembly (2 screws).
5. Insert the fan control wires and the upper portion of the fan control through the 3/4" (19mm) diameter hole on the bottom side of the top heat shield. The fan control wires will enter into the top portion of the heater and the fan control disc will be facing the main burner. Attach fan control to the bottom side of the top heat shield with (2) screws provided with the optional blower.
6. Route cord set through 9/16" (14mm) diameter hole on casing assembly back. Insert approximately 3" (76mm) of cord set into casing assembly back.
7. When you are facing the front of the heater, position the optional blower assembly onto the top heat shield of the heater. The motor wire harness should be facing into the top, right portion of the heater.
8. Attach (1) pin terminal from black (hot) wire, smooth insulation on cord set to (1) socket terminal on fan control wire harness.
9. Attach (1) pin terminal from black (neutral) wire, ribbed insulation on cord set to (1) socket terminal from white (neutral) wire on motor wire harness.
10. Attach (1) pin terminal on fan control wire harness to (1) socket terminal from black (hot) wire on motor wire harness.
11. Attach the green ground wire from the motor wire harness and the green ground wire from the cord set to the bottom right side of the blower housing with (1) screw provided with the optional blower.
12. With the heater standing upright, position the air discharge opening of the blower housing downward. Place the bottom flange of the blower housing over the top edge of the top heat shield. Insert the blower housing into the top portion of the heater by pivoting the blower housing upward 90°. Attach the blower housing to the casing assembly with (4) screws provided with the optional blower.

13. Grasp cord set at casing assembly back and pull excess cord set through casing assembly back. Secure cord set in casing assembly back with the strain relief provided with the optional blower.
14. Installation of optional blower SRB-18TW or SRB-30TW is completed.
15. If heater was removed from the wall, in order to install SRB-18TW or SRB-30TW optional blower, check for gas leaks at all gas connections before lower louver is replaced onto casing assembly.

Attention! After optional blower has been installed use the following steps to properly align the upper louver and the reflector with the heat shield.

- A. When replacing upper louver, be sure the bottom lip of upper louver goes behind the heat shield.
- B. When replacing reflector, be sure the top lip of reflector goes in front of the heat shield.

Excessive Blower Wheel Noise

ATTENTION! If your blower assembly develops a squeal, hum or grinding noise, it indicates dirt or debris on shaft of blower wheel. Use the following steps to clean shaft of blower wheel.

1. Remove red rubber grommet with brass bushing or black rubber grommet with brass bushing from end of blower wheel shaft opposite motor.
2. Clean blower wheel shaft with cotton cloth.
3. Place 1 or 2 drops of all purpose oil on END of blower wheel shaft.
4. Replace red rubber grommet with brass bushing or black rubber grommet with brass bushing onto end of blower wheel shaft. Attention: The red rubber grommet with brass bushing or the black rubber grommet with brass bushing must "snap-back" into position.
5. Cleaning of blower wheel shaft is completed.

⚠ WARNING

Failure to position the parts in accordance with these diagrams or failure to use only parts specifically approved with this heater may result in property damage or personal injury.

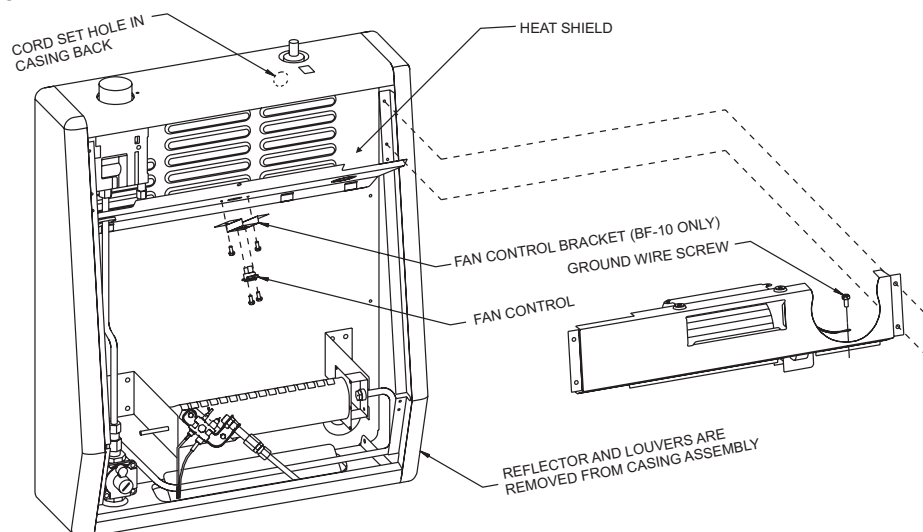

OPTIONAL BLOWER INSTALLATION INSTRUCTIONS (CONT'D)

Wiring

The appliance, when installed, must be electrically grounded in accordance with local codes or, in the absence of local codes, with the National Electrical Code, ANSI/NFPA 70, if an external electrical source is utilized. This appliance is equipped with a three-prong [grounding] plug for your protection against shock hazard and should be plugged directly into a properly grounded three-prong receptacle. Do not cut or remove the grounding prong from this plug. For an ungrounded receptacle, an adapter, which has two prongs and a wire for grounding, can be purchased, plugged into the ungrounded receptacle and its wire connected to the receptacle mounting screw. With this wire completing the ground, the appliance cord plug can be plugged into the adapter and be electrically grounded.

⚠ WARNING

Label all wires prior to disconnection when servicing controls. Wiring errors can cause improper and dangerous operation. Verify proper operation after servicing.

Blower Motor

The blower motor does not have oiling holes. Do not attempt to oil the blower motor.

Blower Wheel

The blower wheel will collect lint and could require periodic cleaning. If the air output decreases or the noise level increases, it indicates a dirty blower wheel.

To clean blower wheel:

1. Turn OFF gas supply to the heater.
2. Turn OFF electrical supply to the heater.
3. Remove lower louver from casing assembly (2 screws).
4. Remove reflector from casing assembly (2 screws).
5. Remove upper louver from casing assembly (2 screws).
6. Clean blower wheel with a vacuum cleaner.
7. As parts are being replaced in reverse order, check for gas leaks at all gas connections before lower louver is replaced onto casing assembly.

⚠ WARNING

Unplugging of blower accessory will not stop the heater from cycling. To turn off gas to the unvented heater: Push in gas control knob slightly and turn clockwise to "OFF." Do not force.

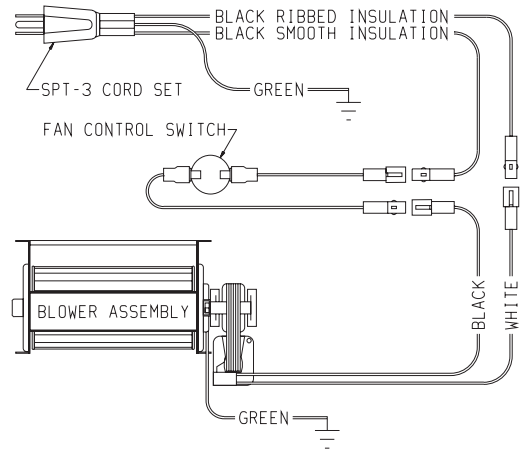
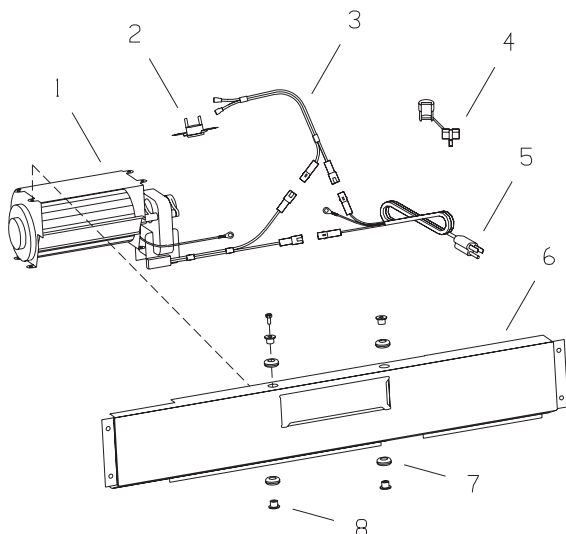

If any of the original wire as supplied with the appliance must be replaced, it must be replaced with type 125°C wire or its equivalent.

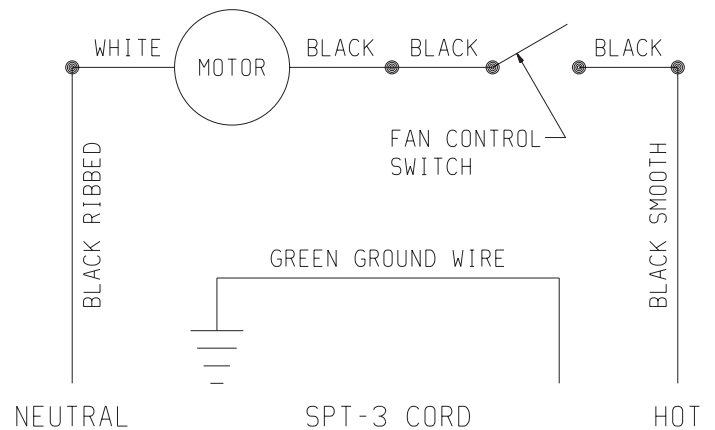

PARTS LIST

INDEX NO.	PART NO.	DESCRIPTION
1	R-2396	BLOWER (INCLUDES MOTOR, FAN, AND FAN HOUSING)
2	R-2503	FAN CONTROL
3	R-2395	WIRE ASSEMBLY
4	R-1468	BUSHING - HEYCO #SR5KN4
5	R2099	CORD SET ASSEMBLY
6	39873	BLOWER PAN (SRB-18TW)
6	39874	BLOWER PAN (SRB-30TW)
7	R-1499	RUBBER GROMMET (4 REQUIRED)
8	R-1454	BRASS BUSHING (4 REQUIRED)
N/S	39893	BLOWER HARDWARE PACKAGE

MASTER PARTS DISTRIBUTOR LIST

To Order Parts Under Warranty, please contact your local Empire dealer. See the dealer locator at www.empirecomfort.com. To provide warranty service, your dealer will need your name and address, purchase date and serial number, and the nature of the problem with the unit.

To Order Parts After the Warranty Period, please contact your dealer or one of the Master Parts Distributors listed below. This list changes from time to time. For the current list, please click on the Master Parts button at www.empirecomfort.com.

Please note: Master Parts Distributors are independent businesses that stock the most commonly ordered Original Equipment repair parts for Heaters, Grills, and Fireplaces manufactured by Empire Comfort Systems Inc.

Dey Distributing

1401 Willow Lake Boulevard
Vadnais Heights, MN 55101

Phone: 651-490-9191

Toll Free: 800-397-1339

Website: www.deydistributing.com

Parts: Heater & Hearth

F. W. Webb Company

200 Locust Street
Hartford, CT 06114

Phone: 860-722-2433

Toll Free: 800-243-9360

Fax: 860-293-0479

Toll Free Fax: 800-274-2004

Websites: www.fwwebb.com & www.victormfg.com

Parts: Heater & Hearth and Grills

East Coast Energy Products

10 East Route 36
West Long Branch, NJ 07764

Phone: 732-870-8809

Toll Free: 800-755-8809

Fax: 732-870-8811

Website: www.eastcoastenergy.com

Parts: Heater & Hearth and Grills

HOW TO ORDER REPAIR PARTS

Parts Not Under Warranty

Parts can be ordered through your Service Person, Dealer, or a Master Parts Distributor. See this page for the Master Parts Distributors list. For best results, the **service person or dealer** should order parts through the distributor. Parts can be shipped directly to the **service person/dealer**.

Warranty Parts

Warranty parts will need a proof of purchase and can be ordered by your Service Person or Dealer. Proof of purchase is **required** for warranty parts.

All parts listed in the Parts List have a Part Number. When ordering parts, first obtain the Model Number and Serial Number from the name plate on your equipment. Then determine the Part Number (**not** the Index Number) and the Description of each part from the following illustration and part list. Be sure to give all this information . . .

Appliance Model Number _____ Part Description _____

Appliance Serial Number _____ Part Number _____

Type of Gas (Propane or Natural) _____

Do not order bolts, screws, washers or nuts. They are standard hardware items and can be purchased at any local hardware store.

Shipments contingent upon strikes, fires and all causes beyond our control.

WARRANTY TERMS

Empire Comfort Systems Inc. warrants this space heating product to be free from defects at the time of purchase and for the periods specified below. Space heating products must be installed by a qualified technician and must be maintained and operated safely, in accordance with the instructions in the owner's manual. This warranty applies to the original purchaser only and is not transferable. All warranty repairs must be accomplished by a qualified gas appliance technician.

Limited Lifetime Parts Warranty with a Five-Year Limited Labor Warranty – Combustion Chamber and Heat Exchanger

If the combustion chamber or heat exchanger (see parts list) fails because of defective workmanship or material, Empire will repair or replace at Empire's option. Within five years from the date of purchase, Empire will pay reasonable labor to have the defective part repaired or replaced at Empire's option.

Limited Five-Year Parts & Labor Warranty – All Other Components (Except Thermostats)

Should any part fail because of defective workmanship or material within five years from the date of purchase, Empire will repair or replace at Empire's option. Within five years from the date of purchase, Empire will pay reasonable labor to have that defect repaired at Empire's option.

Limited One-Year Parts Warranty – Remote Controls, Thermostats, Accessories, and Parts

Should any remote control, thermostat, accessory, or other part fail because of defective workmanship within one year from the date of purchase, Empire will repair or replace at Empire's option.

Duties of the Owner

The appliance must be installed by a qualified installer and operated in accordance with the instructions furnished with the appliance. A bill of sale, cancelled check, or payment record should be kept to verify purchase date and establish warranty period. Ready access to the appliance for service.

What Is Not Covered

Damages that might result from the use, misuse, or improper installation of this appliance.
Travel, diagnostic costs and freight charges on warranted parts to and from the factory.
Claims that do not involve defective workmanship or materials.
Unauthorized service or parts replacements.
Removal and reinstallation cost.
Inoperable due to improper or lack of maintenance.

How To Get Service

To make a claim under this warranty, please have your receipt available and contact your installing dealer. Provide the dealer with the model number, serial number, type of gas, and purchase verification. The installing dealer is responsible for providing service and will contact the factory to initiate any warranted parts replacements. Empire will make replacement parts available at the factory. Shipping expenses are not covered. If, after contacting your Empire dealer, service received has not been satisfactory, contact: Consumer Relations Department, Empire Comfort Systems Inc., PO Box 529, Belleville, Illinois 62222, or send an e-mail to info@empirecomfort.com with "Consumer Relations" in the subject line.

Your Rights Under State Law

This warranty gives your specific legal rights, and you may also have other rights, which vary from state to state.



SINCE 1932

Empire Comfort Systems Inc.
Belleville, IL

If you have a general question about our products, please e-mail us at info@empirecomfort.com.

If you have a service or repair question, please contact your dealer.

www.empirecomfort.com