

This Owner's Manual is provided and hosted by [Appliance Factory Parts](#).



CHAMPION 4000CRLD4 Owner's Manual

[Shop genuine replacement parts for CHAMPION
4000CRLD4](#)



[Find Your CHAMPION Evaporative Cooler Parts - Select From 82 Models](#)

----- Manual continues below -----



INSTALLATION & OPERATION MANUAL

CHAMPION ELITE LOW PROFILE COOLER

Circle the model of your cooler and record the serial number.
Encierre con un círculo el modelo de su enfriador y escribe el número de serie.

4000 RLD4
4000 CRLD4

Date of Purchase:
 Fecha de compra: _____

Serial Number:
 Número de serie: _____

READ CAREFULLY ALL OF THIS MANUAL BEFORE INSTALLING THE UNIT

TABLE OF CONTENTS

Safety Instructions.....	1
How Evaporative Coolers Work.....	1
Installation	2
Operation.....	6
Air Balancing Methods	7
Maintenance	8
Specification Tables.....	9
Troubleshooting	9
Illustrated Parts List	10
Limited Warranty	12

READ AND SAVE THESE INSTRUCTIONS

SAFETY RULES

1. Read all instructions carefully.
2. Electrical connections should be done by a qualified electrician, so that all electrical wiring will conform to your local codes.
3. Always turn OFF POWER and UNPLUG motor and pump inside the cooler before installing or performing any maintenance.
4. Your cooler will run on either 120V or 240V A.C., single phase, 60 Hz (cycle) current.
5. Motor and pump have a grounded, molded plug and an automatic thermal overload switch which will shut motor off when it overheats. The motor will restart automatically when it cools down.

⚠ WARNING: To reduce the risk of fire or electric shock, do not use this fan with any "solid-state fan speed control device."

HOW EVAPORATIVE COOLERS WORK

Evaporative cooling is nature's way of cooling. When air is moved over a wet surface, water is evaporated and heat is absorbed. When stepping out of swimming pool with the wind blowing, evaporative cooling makes you feel cool, even though the air may be warm.

This unit works on the same principle. Air is drawn across wet filter pads where the air is cooled by evaporation and then circulated throughout the building. It is this combination of cooled air and the movement of air over the skin which makes it feel cool.

Unlike refrigeration systems which recirculate the air, an evaporative cooler continually brings in fresh air while exhausting old air. You are completely replacing the air every 2 to 4 minutes by opening windows or doors, by using Up-Dux® ceiling vents, or a combination of both. The air is always fresh, not stale, laden with smoke and odors as happens with refrigerated air conditioning.

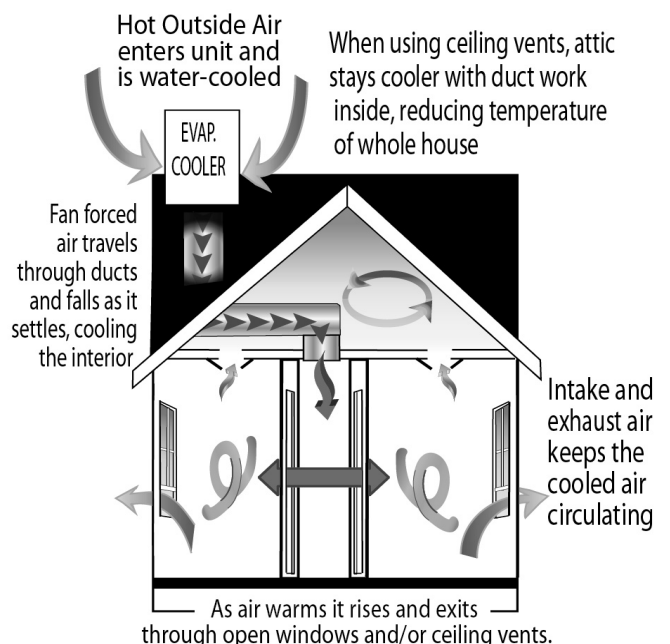

INSTALLATION

⚠CAUTIONS:

Before installing the cooler, note the following items:

- Before installation, ensure your existing electrical system is rated for the additional amperage draw from unit.
- Installation inside attic areas is NOT recommended.
- If installing on brace, or existing construction, ensure structure will hold the operating weight of the cooler. (See specification table for operating weight.)
- Ensure entire unit is sufficiently supported.
- We strongly recommend consulting a professional contractor if installation will require cutting through existing structure such as walls or roof.
- Do not screw or drill into the bottom pan.
- Ensure all electrical work is accomplished to local standards. An electrician may be needed for correct and safe wiring.

⚠WARNING: Disconnect all electrical service that will be used for this unit before beginning the installation and DO NOT reconnect until installation is complete.

⚠CAUTION: To minimize the potential of water entering building, roof penetration should be limited to the size of the duct opening from the unit. This roof penetration must then be sealed properly. The overflow drain must be allowed to drain outside any curb or roof penetration.

PARTS AND TOOLS NEEDED:

- 5/32 Allen Wrench (for pulley installation)
- 7/16 Wrench or Crescent Wrench
- Phillips Screwdriver
- Sill cock or water valve and tubing
- Multimeter (for amp reading)

LOUVERED SIDE PANELS.

The louver panels have a locking latch on each top corner to secure it in place. To remove the louvered panel you will need to loosen the latch screws on either side of the panel. Loosen the screws enough to rotate the latch handle, but do not remove completely. Rotate the latch handle towards the center of the louvered panel. Tilt the top of the louver panel outward away from the top pan and lift out from cooler.

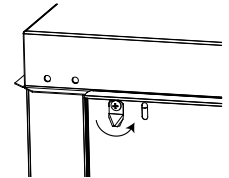

To reinstall the panel, first insert the bottom of the panel into the bottom pan. Tilt the panel forward so that it rests against the top pan. You will need to keep the latch handles rotated to the side to keep the lock from hitting the top pan. Once the louver panel is in place, rotate the latch handle so that the handle is facing down. Tighten the screws to lock latch and secure panel in place.

ELECTRICAL CONNECTION

⚠WARNING: Electrical connections should be accomplished by a qualified electrician to ensure all electrical wiring conforms to local standards.

⚠WARNING: Follow all safety precautions when working with electrical power.

⚠WARNING: Before proceeding with installation, ensure electrical power is disconnected until installation is complete.

Standard Model 4000RLD4

Note: This unit comes with the motor and pulley installed. The unit can be controlled with a manual 6 position switch found at a local hardware store, or with a thermostat such as Champion's Masterstat® Wall Control Thermostat model #110423-2. For thermostat installation refer to its operating manual. Follow the steps below for manual switch installation:

1. Determine a location on a wall inside the home for the 6 position switch.
2. Supply 120V or 240V power to switch, depending on motor and pump voltages.
3. Remove screws securing junction box to cooler cabinet.
4. Bring four conductors plus a ground from switch to cooler junction box.

⚠CAUTION: Make sure to use correctly sized wire and follow all local electrical codes.

5. Connect the four conductor wires to the leads of the motor and pump receptacles located in the junction box. Follow the connection diagrams for 120V or 240V installations.

6. Reinstall junction box to cooler cabinet.
7. Plug motor and pump plugs into receptacles.
8. Follow switch electrical instructions for connecting the four conductors and power leads to switch.

⚠Warning: Pump cord must be secured in retaining clip to prevent contact with water.

ELECTRICAL WIRING DIAGRAMS - STANDARD MODEL 4000RLD4

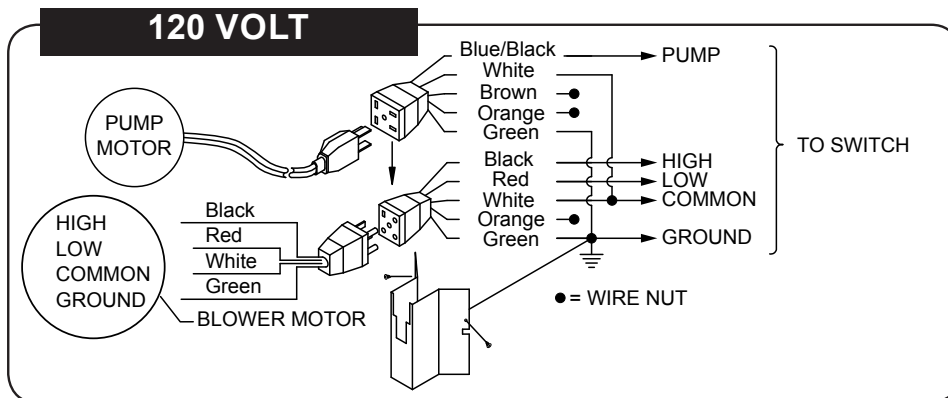

⚠CAUTION: Receptacles in junction box are only for Motor and pump. Do not plug anything else into receptacle.

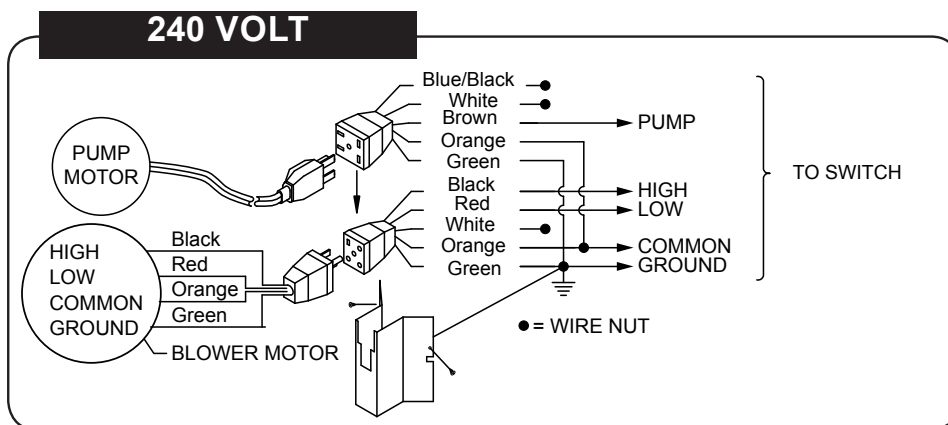

⚠WARNING: Ensure cooler cabinet is properly grounded to a suitable ground connection for maximum safety and protection of equipment.

Contractor Model 4000CRLD4

Note: This unit comes with the motor, pulley, and thermostat control box installed. The unit is factory wired and for 120V power. The supply power should be adequately protected against overloads and short circuits.

Supply Power to Unit

1. A disconnect switch (not included) should be installed near the unit.
2. Run a 2 conductor wire with ground from the power source to the disconnect switch box.
⚠CAUTION: Make sure to use correctly sized wire and follow all local electrical codes.
3. Remove the screws securing the electrical junction box in the unit to gain access to the power lead wires.
4. Connect the power leads and ground wire from the unit junction box to the disconnect switch.
5. Reinstall the junction box to the unit.

Wall Thermostat Installation

1. Find a suitable location for the wall thermostat (away from sources of heat, sunlight, or ventilation, and between 4 and 6 feet from the floor). The thermostat may be mounted to a standard electrical box.
2. Route an insulated three or four-conductor thermostat cable (or similar) from the Control Box inside the cooler to the thermostat electrical box. This cable is not supplied.
⚠WARNING: The thermostat cable should not be routed next to or enter the cabinet through the same inlet as the power supply wire.
3. Connect the thermostat wires to the terminals on the back of the wall control and to the terminals located on the left side of the control box in the unit. Make sure to follow the color code found next to each terminal.

ELECTRICAL WIRING DIAGRAM - CONTRACTOR 4000CRLD4 COOLER

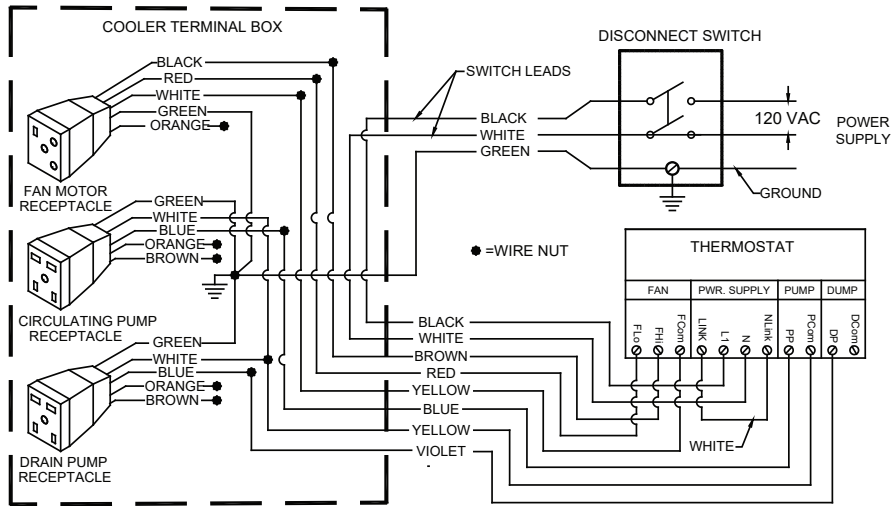

WATER CONNECTION

Note: Do not connect the water supply to any soft water applications.

OVERFLOW INSTALLATION

1. Remove nut and place nipple through the hole in the pan with the rubber washer between the pan and the head of the drain nipple.
2. Screw nut onto nipple and draw up tight against bottom pan.
3. Screw overflow pipe into nipple. This overflow pipe may be removed to drain pan when necessary.

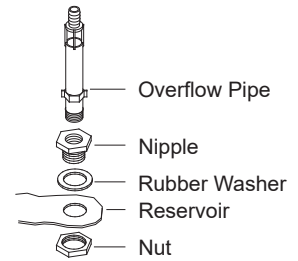

Note: A garden hose may be screwed onto the drain nipple to drain water away from the unit.

WATER SUPPLY INSTALLATION

A steady water supply is required for the operation of this cooler. A saddle valve or sillcock valve is required to connect to a local water supply. These can be purchased from a local hardware store.

1. Install saddle valve to an interior cold water pipe, or install a sillcock valve to an exterior faucet as shown.
2. Run 1/4" plastic or copper tubing from the valve to the unit.
3. Install one end of tubing to water valve by placing nut and ferrule on tubing and tightening the nut until water tight.

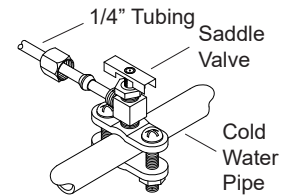

FLOAT VALVE INSTALLATION (Refer to illustration below)

1. Remove items 2, 3, 4, and 5 from float.
2. Insert float body through hole in the corner post or float bracket as shown.
3. Install washer (2) and nut (3). Tighten to keep float from turning. Place nut (5) and ferrule (4) on water supply line. Connect to float fitting and tighten until water tight.

Note: After installation is complete and water is turned on, the float level will need to be adjusted.

4. Bend rod to adjust float. Water level should be about 1 inch below the top opening of the overflow pipe.

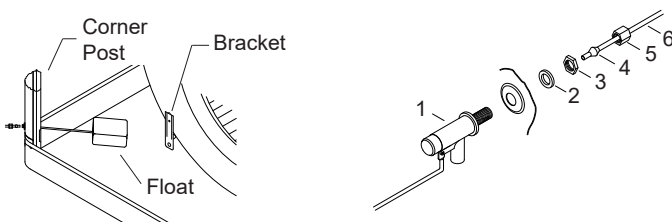
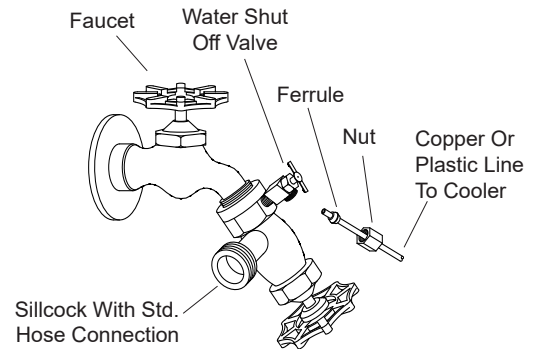

SCALE BUILDUP PREVENTION

As water evaporates, minerals that were in the water will remain. Over time this accumulation of minerals will cause scaling on the pads and in the reservoir. We recommend the installation of either a bleed-off kit (included in standard 4000RLD4 unit) or a purge pump (installed in contractor 4000CRLD4 unit) to help prevent scale build up and increase the life of the unit. A purge pump will drain the pan every few hours of pump operation, to keep fresh water in the unit. A bleed-off kit will continually bleed off a small portion of water while the pump is running allowing fresh water to continually replace the old stagnate water. Follow the instructions below for installing the bleed-off kit.

1. Cut the pump hose and insert the barbed ends of the bleeder tee into each cut end.
2. Insert one end of the bleeder tubing onto the bleeder tee and run the other end out of the cooler through the overflow pipe.

Note: A restrictor clamp is provided which, if desired, may be installed onto the bleeder tubing to restrict the amount of water being bleed off. The amount of water to bleed off depends on the quality of the water in your area. Start with 1-2 gal/hr and increase if needed.

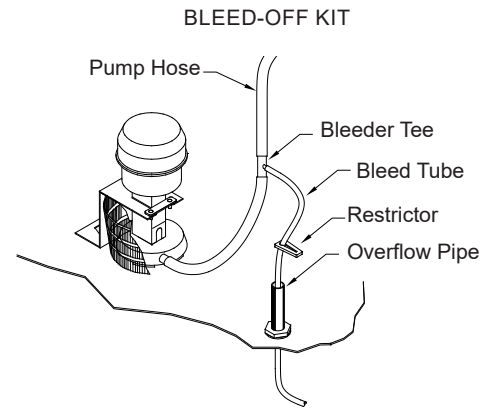

AMPERAGE DRAW AND BELT TENSION

⚠CAUTION: No attempt should be made to completely install this unit without the aid of an electrician or someone familiar with testing amperage draw. Failure to comply with these instructions may void your warranty.

This unit is equipped with an adjustable motor drive pulley for adjusting the blower wheel speed to the proper loading for different duct systems. It is important that the motor drive pulley is adjusted to correct size to ensure maximum air delivery without damage to the motor. Be sure to follow these instructions carefully.

1. Ensure electrical connection of unit is complete and in accordance with all safety standards and local requirements.
2. Reinstall inspection panels. Apply power, turn water and pump on and allow cooler to run for a few minutes to wet pads.
3. Turn off the pump and check amperage and verify it conforms to amperage listed on the specification label on motor.
 - If amperage draw is less than motor rating, disconnect electrical power and remove louvered sides. Unplug motor inside cooler, this will protect you from someone turning the unit on while you are working inside. This should be done for your safety. Adjust pulley to a larger diameter and readjust belt tension. Plug motor in, install louvered side, and retest amperage draw. Repeat this process until correct amperage draw is attained.

Note: Increasing motor pulley diameter increases amperage draw. Decreasing motor pulley diameter decreases amperage draw.

⚠CAUTION: DO NOT operate cooler with larger amperage draw than specified on motor plate. Motor damage will occur.

4. Check belt tension after adjusting pulley. A 3 lb. force should deflect the belt 3/4 inches. Readjust belt if needed by loosening adjustment screw, rotate motor until you have the correct belt tension, then re-tighten screw.

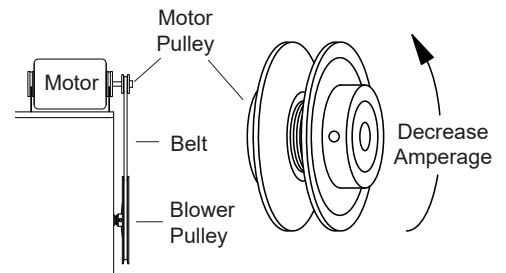

BELT TENSION

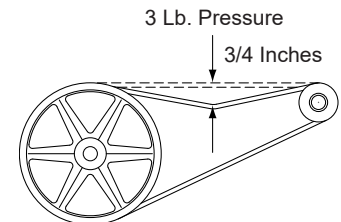

OPERATION

NOTES: These coolers may be used without water for ventilation purposes. When outside air is cool (for example, at night) or when humidity is high the water pump can be turned off.

To eliminate the delivery of hot air when starting the cooler, start the pump only for the first few minutes, then turn on the blower motor.

THERMOSTAT OPERATION (CONTRACTOR MODEL 4000CRLD4)

Automatic Operation (Cool Mode)

The fan and water pump are controlled automatically to achieve the desired comfort level.

This mode is activated by pressing the 'Mode' button until 'Auto' is displayed on the LCD. The 'Mode' button changes the control from Off to Auto to Manual and back to Off.

The Set temperature (the target temperature for control) may be altered by repeatedly pressing or holding the 'Up' or 'Down' buttons. The LCD will display the 'Set' rather than 'Room' temperature for a short time after pressing the 'Up' or 'Down' button.

On starting or after the pump has been off for a period of time, the pump will start without the fan to allow the media to absorb water. This is called Pre-wet and lasts for 2 minutes, indicated by 'Pre-Wet' flashing on the LCD. The Pre-Wet cycle can be bypassed by pressing the 'Fan' button and then pressing the 'Mode' button until 'Auto' is displayed.

The thermostat will cycle the fan setting between High speed, low speed and off depending on room temperature. If the room temperature drops 2 degrees below the set point temperature, the fan will turn off. At 1 degree above the set point temperature, the unit will start on low speed. If the room temperature rises to 4 degrees above the set temperature, the fan will change to high speed and will remain until the room temperature drops to 1 degree above the set point, where it will change to low speed.

The thermostat allows the operator to calibrate the room temperature reading. Pressing the up and down arrows simultaneously for 5 seconds will enter the calibration mode. A temperature adjust setting of -3 to 3°F can be selected. After no activity for 5 seconds, the thermostat will exit the calibration mode and the room temperature will be adjusted by the selected value.

During automatic operation, the control performs a water purge cycle every 8 or 12 hours of pump operation. This interval can be toggled between 8 or 12 hours by simultaneously holding the 'Pump' and 'Fan' buttons for 5 seconds. The selected interval is displayed for a short time. This action also starts a manual dump cycle.

Manual Operation

The fan speed and pump are set by the user.

To activate the manual mode from the 'Off' state, press the 'Mode' button until 'Manual' is displayed. If the control is in the 'Auto' mode, you can change to manual mode by pressing either the 'Mode', 'Fan' or 'Pump' buttons. Pressing the 'Fan' button changes the fan from High to Low to Off and back to High. Pressing the 'Pump' button changes the pump from On to Off and back to On.

The LCD will display 'Manual' on the left and the fan and pump settings on the right. The fan speed will be displayed as Fan Hi or Fan Lo. If neither are displayed the fan is off. The pump status will be displayed by the LCD as 'Cool' (if the fan is running) or 'Pre-Wet' (if the fan is off). With the fan and pump both running 'Cool' will be displayed. If only the fan is running 'Vent' will be displayed.

Time Delay Operation (Timer Mode)

Delayed start or finish in 'Auto' or 'Manual' mode.

The 'Timer' button is used to set a delay period between 1 and 12 hours in 1 hour increments.

If the cooler is operating (in 'Auto' or 'Manual' modes) when the 'Timer' button is pressed, the delay period determines when the cooler switches off. If the cooler is Off when the 'Timer' button is pressed, the delay period determines when the cooler starts in 'Auto' mode. The set temperature will be the last setting when running in 'Auto' mode.

'Timer Delay' and the remaining time are displayed on the LCD while the timer feature is activated.

You can cancel the Timer function at any time by pressing the 'Timer' button. The 'Timer Delay' indicator will no longer be displayed.

In The Event Of A Power Outage

When power is restored after a power outage, the thermostat will resume operation in the mode selected prior to the power outage. If the timer mode is active, the time will be restored to the hour indicated prior to the outage.

AIR EXHAUST

For an evaporative cooler to be effective, there needs to be adequate exhaust. If there is not adequate exhaust, pressure and humidity will build up in the building. You exhaust by opening doors or windows to allow the old stale air in the building to escape. Attic exhaust dampers may also be installed to exhaust the air into the attic. The combination of attic exhaust dampers and a thermostat can provide a completely automatic operation.

An often misunderstood concept of evaporative cooling is the amount of air that should be exhausted. How much should you open your windows? The following two methods will help you determine the amount to open your windows.

WINDOW AREA/CFM METHOD

For proper air flow, allow an opening of at least 2 square feet (288 square inches) for each 1000 CFM rating of your unit.

Example: At 3640 CFM, model 4000RLD4 requires 7.3 square feet (1050 square inches) of opening ($3320/1000 * 2 = 7.3$).

Multiply the number of windows by window width in inches and divide this into the number of square inches required for your size unit. This will give you the height to open windows. In this example, four 36 inch wide windows should be opened 7.3 inches each.

TISSUE SUCTION METHOD

1. Take a piece of tissue paper and cut it lengthwise into 3 equal strips.
2. Turn your cooler on high cool.
3. Open one window at least six inches wide in each room that you want to cool.
4. Take the piece of tissue paper and put it up against the screen of the open window furthest from the cooler discharge opening. Let go of it. It will do one of three things.

IF:	It falls down.	THEN:	CLOSE all of the windows one inch and try step 4 again.
IF:	It plasters itself to the screen.	THEN:	OPEN all of the windows one inch and try step 4 again.
IF:	It stays on the screen lightly.	THEN:	PERFECT. You are done. Enjoy your cooler.

Notes:

- When switching to low cool, you must re-balance your home. Repeat step 4.
- Once you balance your home you can cool some areas more than others by opening those windows more and closing the others by the same amount. Repeat step 4 to make sure your home is still air balanced.

MAINTENANCE

Regular maintenance on your cooler will increase performance and extend the life of your cooler.

⚠️WARNING: Before accomplishing any maintenance ensure power is turned off and the motor and pump are unplugged.

START OF SEASON MAINTENANCE

Accomplish these basic steps before the temperatures require cooling in case you have to acquire replacement parts.

CLEAN OR REPLACE MEDIA

1. With power DISCONNECTED, remove louvered doors.
2. Inspect filter media. Scale buildup on the media will obstruct the airflow and cause the media to be less absorbant. If there is a lot of scale buildup, check the bleed or purge settings. The bleed-off may be plugged, or the purge cycle may need to be more frequent. A dirty filter will be less efficient and will cause a decrease of cooling in the home.
3. If media is dirty, remove from the louvered side. Remove the top media support brackets, loosen the water trough screws and raise water trough, then lift out media.
4. Clean the media with a garden hose. Light scraping may be required to remove mineral deposits. Do not use harsh detergents or pressure washers in cleaning. Make every effort to keep the media intact.
5. The original media has a standard life of 5 years, but in areas with very high mineral content the media may have to be replaced sooner. If cooling efficiency is not adequate, replace the media.
6. When reinstalling existing or installing new replacement pads, we recommend using original equipment, MasterCool® media replacement pads for highest cooling capabilities.

OIL BEARINGS

1. The blower bearings should be oiled each year with non-detergent 20/30 weight oil.
2. Locate and open the oil cup on each of the blower bearings and add a few drops of oil.



CLEAN PUMP

1. Pump should be cleaned at least once a year or more often if debris accumulates.
2. Unplug motor and pump from junction box, and disconnect pump distribution tube.
3. Using a screw driver, pry plastic retaining fasteners straight up out of the pump-mounting bracket.
4. Slide the pump off the mounting bracket.
5. Extract pump from straining basket or netting and remove base of pump.
6. Clean pump, turn impeller to ensure free movement.
7. Remove pump spout and check for blockage.
8. Reinstall pump base and verify it is secure.
9. Before reinstalling pump, check water hose, bleeder line and water distributor tube to ensure there is no blockage in any lines.
10. Reinstall the pump by sliding pump onto mounting bracket and reinserting the plastic retainers to ensure pump stays in upright position.
11. Reinstall pump water distribution tube to the pump outlet spout, making sure it is pressed onto spout securely.

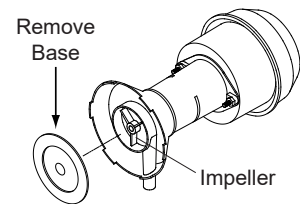

CHECK BELT

1. Before unit is turned on, check that belt condition is good. If belt must be replaced, install same sized belt.
2. Verify belt tension is correct: 3/4" deflection with 3 lbs of force.

END OF SEASON SHUTDOWN

The cooler should be prepared before any extended period of non use, and especially before winter shutdown.

1. Drain all water from unit, supply line and pump to ensure no damage occurs from freezing. Keep water line disconnected from both unit and supply line.
2. Unplug motor and pump from junction box.
3. Clean unit.
4. Cover unit to protect finish for long periods of non use.

GENERAL SPECIFICATIONS							
MODELS	WEIGHT (lbs)		CABINET DIMENSIONS (in.)			DUCT OPENING (in.)	
	SHIPPING	OPERATING	HEIGHT	WIDTH	DEPTH	WIDTH	HEIGHT
4000RLD4 4000CRLD4	218	305	30 1/2	41 1/4	41 1/4	17-3/4	17-3/4

MOTOR SPECIFICATIONS									
MODELS	H.P	MOTOR PN	SPEED	VOLTS	AMPS	WEIGHT (LBS)	PUMP MODEL #	PUMP AMPS	DRIVE BELT P/N
4000RLD4 4000CRLD4	3/4	110449	2	115	10.5	21	110429	0.9	110212 (4L-570)

TROUBLESHOOTING GUIDE		
PROBLEM	POSSIBLE CAUSE	REMEDY
Failure to start or no air delivery	1. No electrical power to unit • Blown Fuse or Tripped Circuit Breaker • Electrical cord damage	1. Check Power • Replace fuse or reset breaker • Replace Cord
	2. Belt too loose or too tight	2. Adjust belt tension
	3. Motor overheated • Belt too tight • Blower bearings dry • Motor pulley diameter too large	3. Determine cause of overheating • Adjust pulley tension • Oil blower bearings • Adjust pulley to correct diameter
	4. Motor locked	4. Replace motor
Inadequate air delivery with cooler running	1. Insufficient air exhaust	1. Open doors or widows to increase air flow
	2. Belt too loose	2. Adjust belt tension or replace if needed
	3. Pads plugged/dirty	3. Clean pads
	4. Motor underloaded	4. Adjust pulley
Water draining onto roof	1. Float arm not adjusted properly	1. Adjust float
	2. Overflow assembly leaking	2. Tighten nut and overflow pipe
Musty or unpleasant odor	1. Stale or stagnate water in cooler	1. Drain pan and clean pads
Motor cycles on and off	1. Low voltage	1. Check voltage
	2. Excessive belt tension	2. Adjust belt tension
	3. Blower shaft and tight or locked	3. Unplug unit and oil or replace bearings
	4. Bearings dry	4. Oil bearings
	5. Motor pulley diameter too large , causing motor overload	5. Adjust pulley so full load ampere rating of motor is not exceeded.
Noisy	1. Bearings dry	1. Oil bearings
	2. Wheel rubbing blower housing	2. Unplug unit, inspect and realign
	3. Loose parts	3. Tighten loose parts
Inadequate cooling	1. Inadequate exhaust in house	1. Open windows or doors to increase air flow
	2. Pads not wet • Pads clogged • Distribution tube holes clogged • Pump not working properly	2. Check water distribution system • Clean pads • Clean tube holes • Unplug and replace or clean pump
	1. Insufficient air exhaust	1. Open doors or windows

REPLACEMENT PARTS LIST

When ordering parts, please be sure to furnish the following information on all orders. Failure to do so may delay your order.

1. Cooler model number
2. Cooler serial number
3. Motor HP
4. Description and part number
5. Date of purchase

<u>No.</u>	<u>Description</u>	<u>4000 RLD4</u>	<u>4000 CRLD4</u>
1.	Top Pan.....	220905-005	220905-005
2.	Bottom Pan.....	320908-005	320908-005
3.	Louvered Side Assembly.....	324111-106 (4)	324111-106 (4)
4.	Water Trough / <i>Canal De Agua</i>	226003-004 (4)	226003-004 (4)
5.	Pad Set.....	310101-4 (4)	310101-4 (4)
6.	Pad Retainers.....	224111-008 (12)	224111-008 (12)
7.	Corner Post.....	324003-013 (4)	324003-013 (4)
8.	Cut-Off Plate.....	224004-002	224004-002
9.	Blower Housing.....	324110-002	324110-002
10.	Blower Wheel.....	16BW	16BW
11.	Shaft, Blower Wheel.....	110183	110183
12.	Bearings, Blower Wheel Shaft.....	110351 (2)	110351 (2)
13.	Pulley, Blower Wheel.....	110275	110275
14.	Drive Belt.....	110212	110212
15.	Motor.....	110449	110449
16.	Pulley, Motor.....	110278	110278
17.	Motor Mount.....	314003-004	314003-004
18.	Motor Mount Clip Set.....	314005-001	314005-001
19.	Electrical Cord, Motor.....	110372	110372
20.	Float Valve.....	FL-C	FL-C
21.	Pump Mount.....	218001-031	218001-031 (2)
22.	Pump.....	110429	110429
23.	Pump Retainer.....	110714 (3)	110714 (6)
24.	Purge Pump.....	-	110429
25.	Pump Mount Extension Bracket.....	218001-033	218001-033 (2)
26.	Float Bracket.....	216001-003	216001-003
27.	Tube, Water Delivery.....	310716	310716
28.	Over Flow Assembly.....	110610	110610
29.	Water Distributor Assembly.....	3D-7	3D-7
30.	Holder, Water Distributor.....	110574 (8)	110574 (8)
31.	Electrical Junction Box.....	320106-003	320106-003
32.	Receptacle, Motor.....	110393	110393
33.	Receptacle, Pump.....	110361 (1)	110361 (2)
34.	Latch Assembly (2 Per Side).....	318124	318124
35.	MasterStat Thermostat Controls.....	-	110423-2
36.	Liquidtight Conduit.....	-	110816
37.	Liquidtight Connectors.....	-	110817
38.	Bleed-Off Kit.....	310586	-

NOTE: Standard hardware items may be purchased from your local hardware store.

PARTS DRAWING

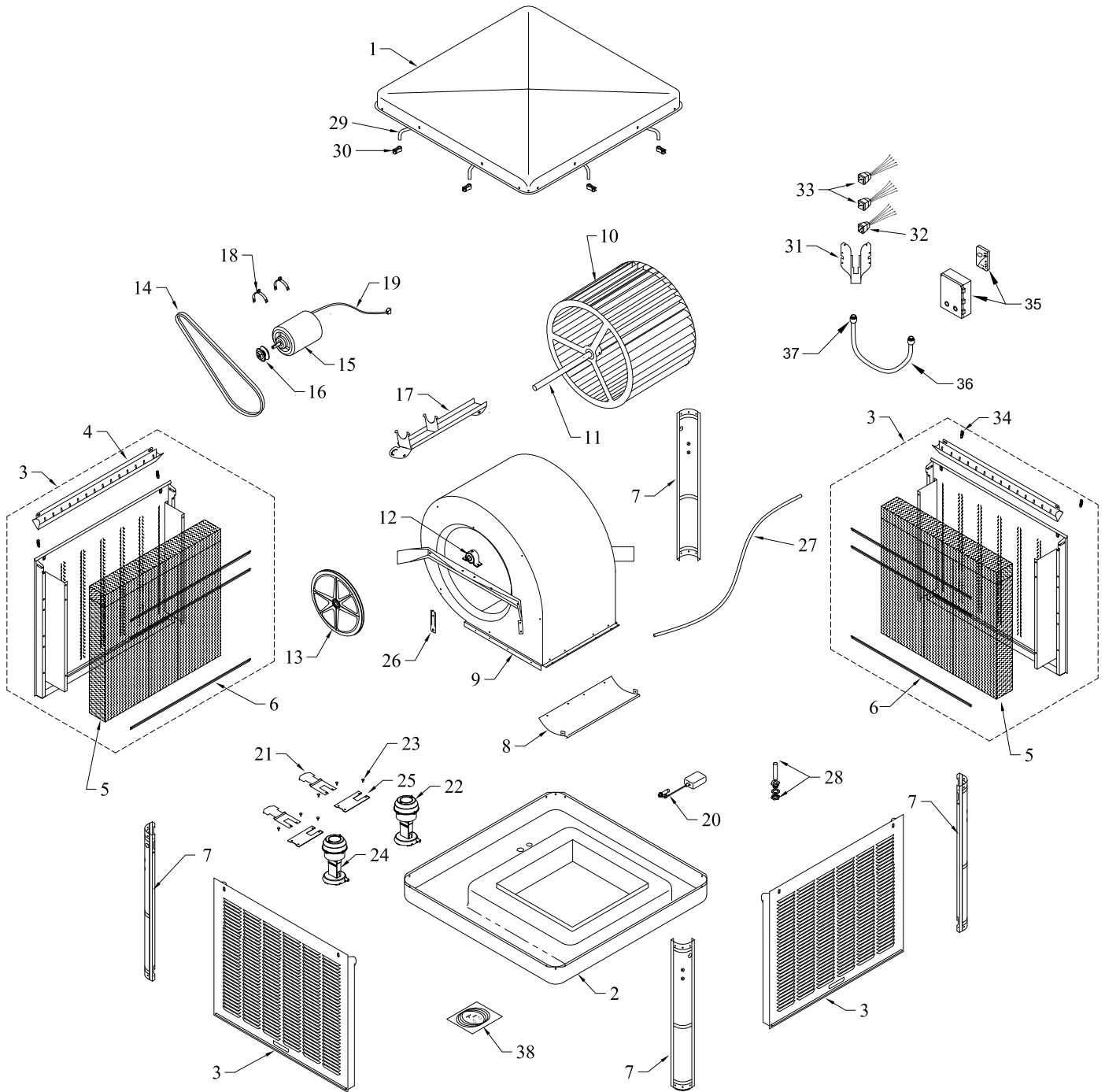

LIMITED WARRANTY POLICY

SALES RECEIPT REQUIRED AS PROOF OF PURCHASE FOR ALL WARRANTY CLAIMS.

This warranty is extended only to the original purchaser of this evaporative cooler when the unit is installed and used under normal conditions against defects in workmanship and materials as follows:

- Two (2) years from date of sale on the cabinet components
- Five (5) years on the evaporative media, which is considered a disposable component and should be replaced periodically.
- Eight (8) years on the bottom pan if water leakage should occur due to rust out

The manufacturer will replace the defective part/product, at its discretion. It is agreed that such replacement is the exclusive remedy available from the manufacturer and that **TO THE MAXIMUM EXTENT PERMITTED BY LAW, THE MANUFACTURER IS NOT RESPONSIBLE FOR DAMAGES OF ANY KIND, INCLUDING INCIDENTAL AND CONSEQUENTIAL DAMAGE OR LOSS OF PROFITS OR REVENUES.**

Some states do not allow limitations on how long an implied warranty lasts, so the above limitations may not apply to you.

Exclusions from this warranty

We are not responsible for any incidental or consequential damage from any malfunction, accident, misuse, alterations, unauthorized repairs, abuse, including failure to perform reasonable maintenance, normal wear and tear.

Alterations include the substitution of name brand components including, but not limited to media pads.

We are not responsible for any damage from the use of water softeners or treatments, chemicals or descaling materials.

We are not responsible for the cost of service calls to diagnose the cause of trouble, or labor charge to repair and/or replace parts.

No employee, agent, dealer or other person is authorized to give any warranties or conditions on behalf of the manufacturer. The customer shall be responsible for all labor costs incurred.

Some states do not allow the exclusion or limitation of incidental or consequential damages, so the above limitations or exclusions may not apply to you.

How to obtain service under this warranty

Within the limitations of this warranty, purchaser with inoperative units should contact the dealer where you purchased the cooler. If for any reason you are not satisfied with the response from the dealer, contact Customer Service at 800-643-8341 for instructions on how to obtain service within warranty as listed above.

This warranty gives the customer specific legal rights, and you may also have other rights which vary from province to province, or state to state.

Register your product at www.championcooler.com.

**Champion Cooler / Essick Air Products
5800 Murray St.
Little Rock, AR 72209
www.championcooler.com**