

This Owner's Manual is provided and hosted by [Appliance Factory Parts](#).



Jenn Air 720-0100-NG Owner's Manual

[Shop genuine replacement parts for Jenn Air
720-0100-NG](#)



[Find Your Jenn Air Grill Parts - Select From 107 Models](#)

----- Manual continues below -----



STAINLESS STEEL GAS GRILL

MODEL NO.: 720-0100-NG

ITEM NO: 109476

Jenn-Air is a Trademark of the Maytag Corporation and is used under license to Lowe's Companies, Incorporated.

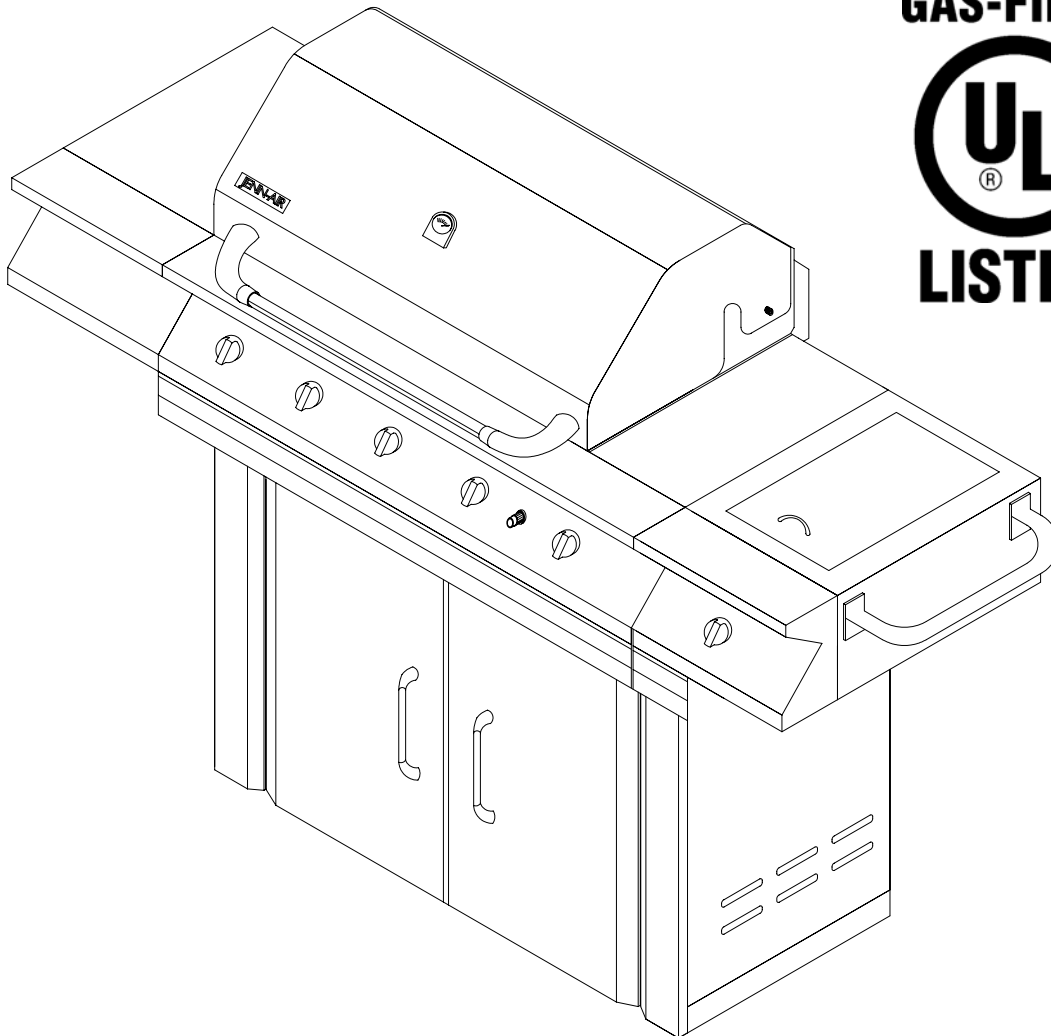

GAS-FIRED



LISTED

FOR OUTDOOR USE ONLY



**PLEASE CONTACT 1-800-554-5799 FOR ASSISTANCE
DO NOT RETURN TO PLACE OF PURCHASE**

TABLE OF CONTENTS

SECTION ONE

Safety Instructions.....	1-3
Placement of the Grill.....	3

SECTION TWO

Side Burner & Side Shelf Assembly.....	4
Side Burner Lid & Handle Assembly	5
Battery, Spice Tray & Brake Assembly.....	6
Installation of Natural Gas Regulator.....	7

SECTION THREE

Gas Hook Up & Leak Testing	8
Installer Final Check.....	9

SECTION FOUR

Operating Instructions.....	10
Lighting Instructions.....	11
To Match Light the Grill.....	12
Easy Lighting Illustrations.....	13
Using the Side Burner	14
Care and Maintenance of Side Burner.....	14
Care and Maintenance of the Grill.....	15
Troubleshooting.....	16

SECTION FIVE

Exploded View.....	17
Parts List	18

SECTION SIX

Grilling Hints	19
Grill Cooking Chart	19-21
Grill Recipe Suggestions	22-23

SECTION SEVEN

Limited Warranty	24
------------------------	----

To reduce the risk of fire, burn hazard or other injury, read this Care and Use Manual carefully and completely before using your grill.

 **WARNING**

Do not attempt to light the grill if gas odor is present. Contact customer service at 1-800-554-5799.

When lighting, keep your face and body as far away from the burner as possible.

BEFORE LIGHTING

Inspect the gas supply hose prior to turning on the gas. If there is evidence of cuts, wear, or abrasion, it must be replaced prior to use.

Only the pressure regulator and hose assembly supplied with the unit should be used. Never substitute regulators for those supplied with the grill. Contact customer service for proper replacement.

Leak check the piping and regulator connections with a soap and water solution before operating the grill (See "Leak Testing" instructions on page 8).

 **LP GAS CYLINDER WARNING**

1. Do not store or use gasoline or other flammable vapors and liquids in the vicinity of this or any other appliance.

USING THE SIDE BURNER

Inspect the gas supply hose prior to turning on the gas. If there is evidence of cuts, wear or abrasion, it must be replaced prior to use. Do not use the side burner if gas odor is present.

Keep a spray bottle of soapy water near the gas supply valve and check the connections before each use.

ROTISSERIE DRIVE MOTOR

To ensure continued protection against electric shock:

Connect to properly grounded outlets only.

Keep extension cord connections dry and off the ground.

Do not expose to rain.

Do not use indoors.

 **WARNING**

If you smell gas:

1. Shut off gas to the grill.
2. Open the top cover or lid.
3. Extinguish any open flames.
4. If the odor continues, immediately call your gas supplier or local fire department.

SAFETY INSTRUCTIONS

WARNING

Do not try lighting this appliance without first reading the "LIGHTING INSTRUCTIONS" section of this manual.

TESTED IN ACCORDANCE WITH ANSI Z21.58b LATEST STANDARD and CGA 1.6b LATEST STANDARD FOR OUTDOOR COOKING GAS APPLIANCES.

Check your local building codes for the proper method of installation. In the absence of local codes, this unit should be installed in accordance with the National Fuel Gas Code ANSI Z223.1/NFPA 54, Storage and Handling of Liquefied Petroleum Gases, ANSI/NFPA 58 or CSA B149.1 Natural Gas and Propane Installation Code, and the National Electrical Code, ANSI/NFPA 70.

CALIFORNIA PROPOSITION 65-WARNING

The burning of gas fuel generates some by-products, which are known by the State of California to cause cancer or reproductive harm. To minimize exposure to these substances, always operate this unit according to the care and use manual, ensuring you provide good ventilation when cooking with gas.

SAFETY PRACTICES TO AVOID INJURY

When properly cared for, your grill will provide safe, reliable service for many years. However, extreme care must be used as the grill produces intense heat that can increase accident potential.

When using this appliance basic safety practices must be followed, including the following:

Do not repair or replace any part of the grill unless specifically recommended in this manual. All other service should be referred to a qualified technician.

The grill is for outdoor use only.

The grill is not intended to be installed in or on recreational vehicles and/or boats.

Children should not be left alone or unattended in an area where the grill is being used. Do not allow them to sit, stand or play on or around the grill at any time.

Do not store items of interest to children around or below the grill or cart. Do not allow children to crawl inside the cart.

Never let clothing, pot holders or other flammable materials come in contact with or too close to any grate, burner or hot surface until it has cooled. The fabric could ignite, causing serious personal injury.

For personal safety, wear proper apparel. Loose fitting garments or sleeves should never be worn while using this appliance. Some synthetic fabrics are highly flammable and should not be worn while cooking.

Only certain types of glass, ceramic, earthenware, or other glazed utensils are suitable for grill use. Other types of materials may shatter with sudden temperature changes. Use only on low or medium heat settings in accordance with the manufacturer's guidelines.

Do not heat unopened food containers as a build-up of pressure may cause the containers to burst.

Use a covered hand when opening the grill lid. Never lean over an open grill.

When lighting a burner, always pay close attention to what you are doing. Make certain you are aware of which burner you are lighting so that your body and clothing remain clear of open flames.

SAFETY INSTRUCTIONS

When using the grill, do not touch the grill rack, burner grate or immediate surroundings as these areas become extremely hot and could cause burns. Use only dry potholders. Moist or damp potholders on hot surfaces may cause steam burns. Do not use a towel or bulky cloth in place of potholders. Do not allow potholders to touch hot portions of the grill rack.

Grease is flammable. Let hot grease cool before attempting to handle it. Do not allow grease deposits to collect in the grease tray at the bottom of the grill's firebox. Clean the grease tray often.

Do not use aluminum foil to line the grill racks or grill bottom. This can severely upset combustion air flow or trap excessive heat in the control area.

For proper lighting and performance of the burners, keep the burner ports clean. It is necessary to clean them periodically for optimum performance. The burners will only operate in one position and must be mounted correctly for safe operation.

Clean the grill with caution. To avoid steam burns, do not use a wet sponge or cloth to clean the grill while it is hot. Some cleaners produce noxious fumes or can ignite if applied to a hot surface.

 **INSECT WARNING**
Spiders and other insects can nest inside the burners of this and other grills, which could disrupt gas flow. This dangerous condition could cause a fire behind and beneath the valve panel, damaging the grill and making it unsafe for operation.
Inspect the grill at least twice a year.

Never use a dented or rusty propane tank.

Turn off all control knobs and make certain the grill is cool before using any type of aerosol cleaner on or around it. The chemical that produces the spraying action could, in the presence of heat, ignite or cause metal parts to corrode.

Do not use the grill to cook excessively fatty meats or other products which promote flare-ups.

Do not operate the grill under unprotected combustible constructions. Use only in well ventilated areas. Do not use in buildings, garages, sheds, breezeways or other such enclosed areas.

This unit is intended for outdoor use only.

Keep the areas surrounding the grill free from combustible materials, fluids, trash, and vapors such as gasoline or charcoal lighter fluid. Do not obstruct the flow of combustion and ventilation air. If the unit is stored indoors, make sure it is cool.

Do not use briquettes of any kind in the grill.

The 720-0100-NG grill is designed for optimum performance without the use of briquettes. Do not place briquettes on the flame tamers as this will block the vent to the grill burners. Adding briquettes can damage ignition components and knobs, thus voiding the warranty.

Keep the back of the cart free and clear from debris. Keep electrical supply cords and the rotisserie motor cord away from heated areas of the grill.

Never use the grill in extremely windy conditions. If located in a consistently windy area (oceanfront, mountaintop, etc.), a windbreak will be required. Always adhere to the clearance specifications.

PLACEMENT OF THE GRILL

CLEARANCE

Non-Combustible Construction

A minimum of 3 in. clearance from the back of the grill to non-combustible materials are required for the lid to open fully.

 **WARNING**
Do not install this unit into combustible enclosures. There should be a minimum clearance of 24 in. from all sides to combustible materials.

LOCATION

When determining a suitable location take into account concerns such as exposure to wind, proximity to traffic paths, and keeping gas supply lines as short as possible.

Place the grill in well-ventilated areas. Never place the grill in a building, garage, breezeway, shed or other such enclosed areas. During heavy use, the grill will produce a lot of smoke.

SIDE BURNER & SIDE SHELF ASSEMBLY

1. Open the grill lid and remove the side burner from the fire box (Top drawing).
2. The screws used to attach the side shelf and side burner are already screwed into the side of the grill cart (Top drawing). Remove the screws from the side panels.
3. Align the holes of the left side shelf with those in the grill cart, insert the screws and tighten. The top two screws insert from inside the fire box while the bottom two screws insert from under the left side shelf.
4. Repeat steps 2 and 3 to install the right side burner onto the right side panel.
5. Secure the side burner hose with the two clips located under the side burner shelf (bottom drawing).

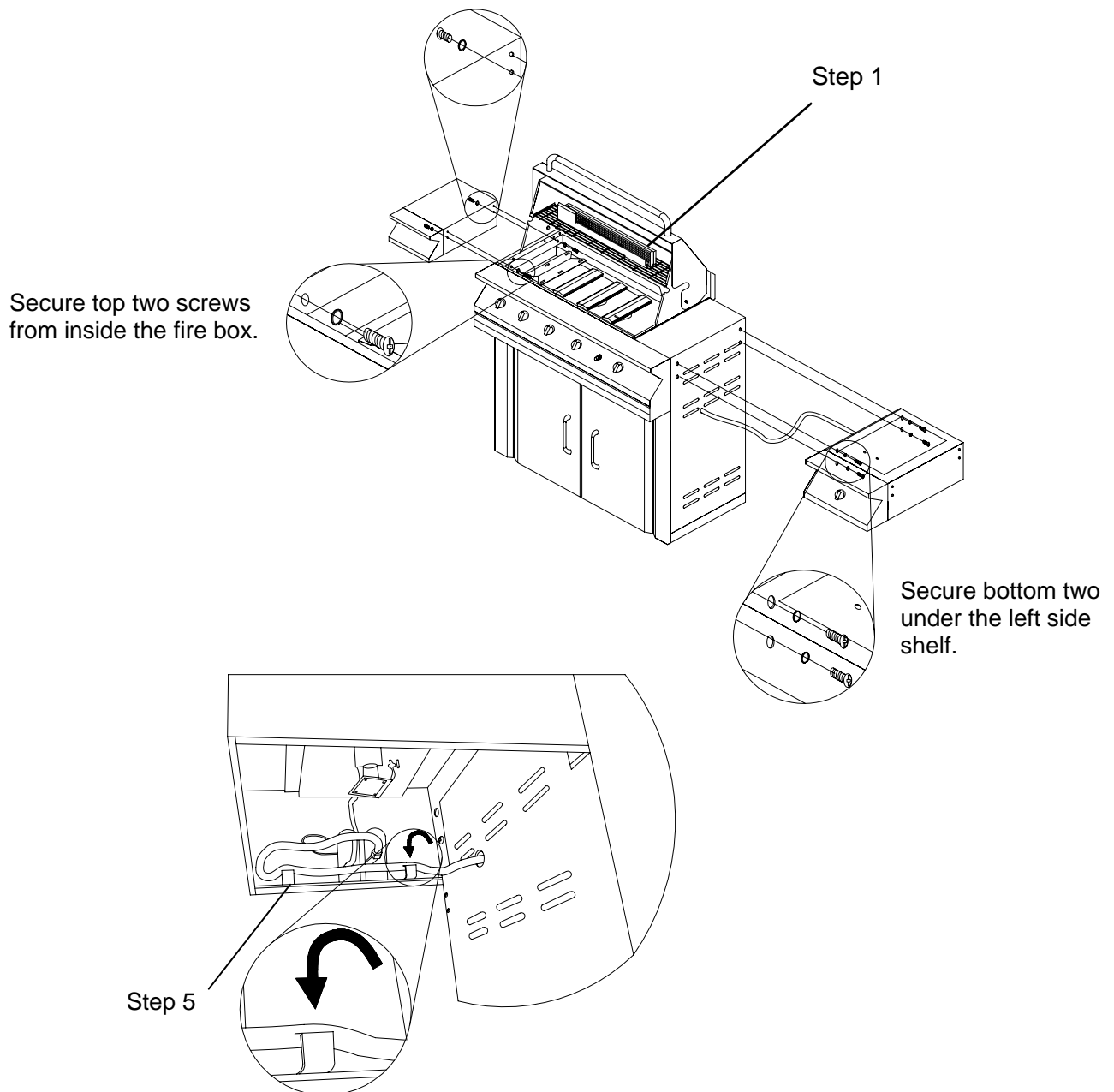

SIDE BURNER LID ASSEMBLY

1. Open the lid and cut the plastic tie.
2. Remove the screws from the handle and reinsert them through the side burner lid.
3. Tighten the screws.

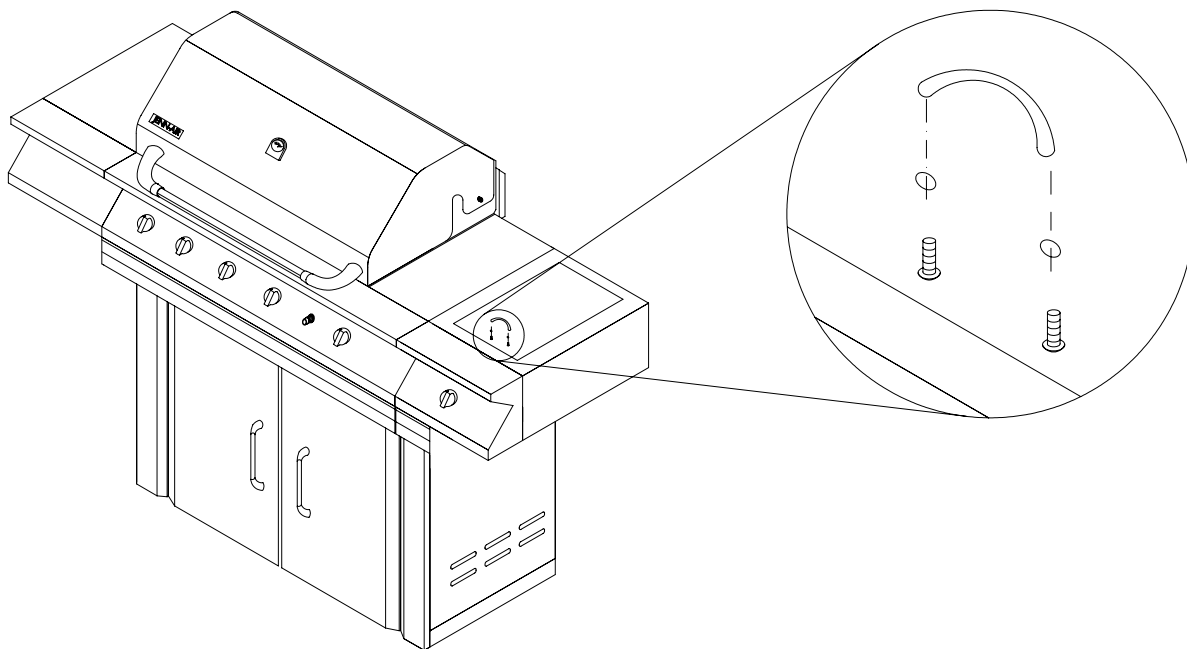

SIDE BURNER HANDLE ASSEMBLY

1. Remove the four handle screws from the side of the burner shelf.
2. Align the side burner handle holes with the holes in the shelf.
3. Insert the screws and tighten.

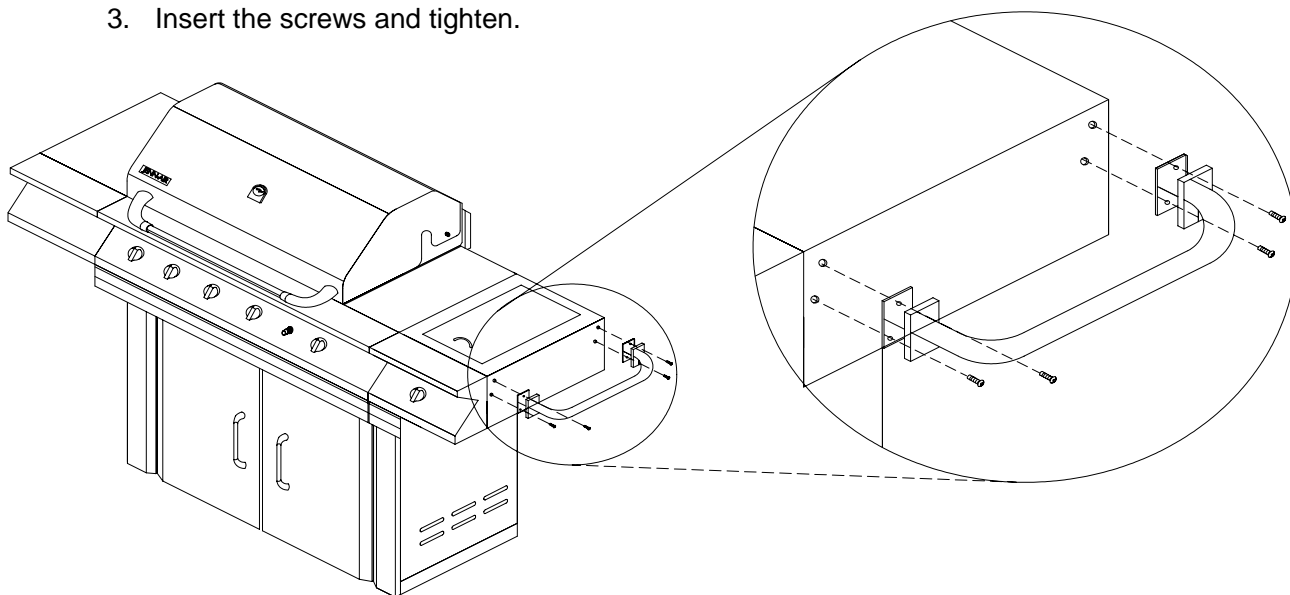

BATTERY ASSEMBLY

1. Remove the ignition button housing.
2. Insert the battery into the housing with the positive side facing outward.
3. Replace the ignition button housing after the battery has been installed.

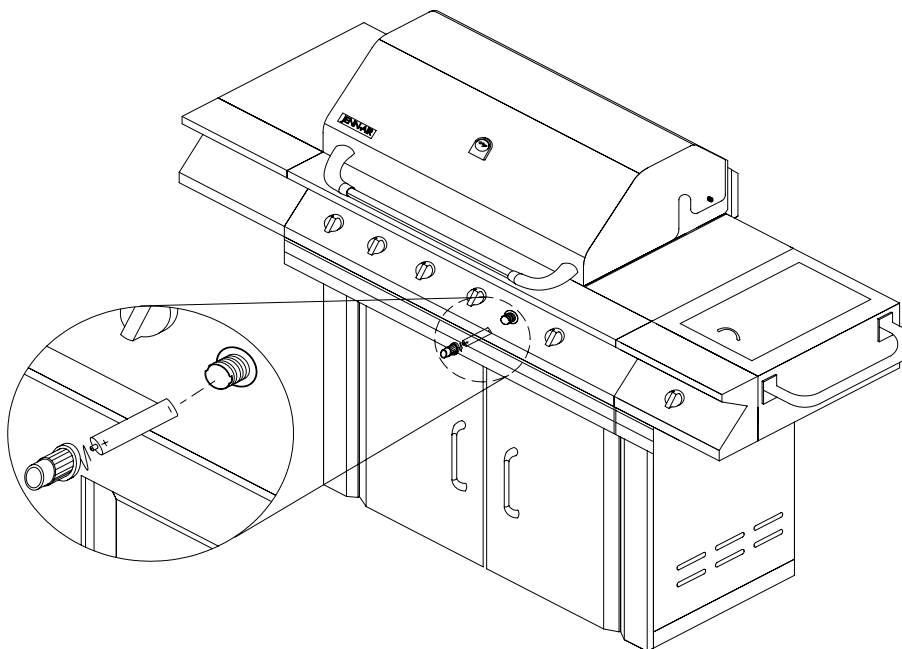

SPICE TRAY & BRAKE ASSEMBLY

Lift the red handle upward to lock the caster brake.

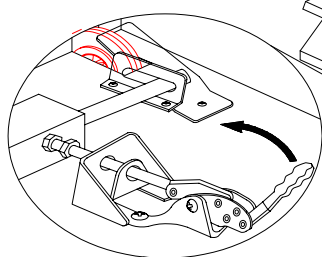

Mount the spice tray into the holes on the left door of the grill.

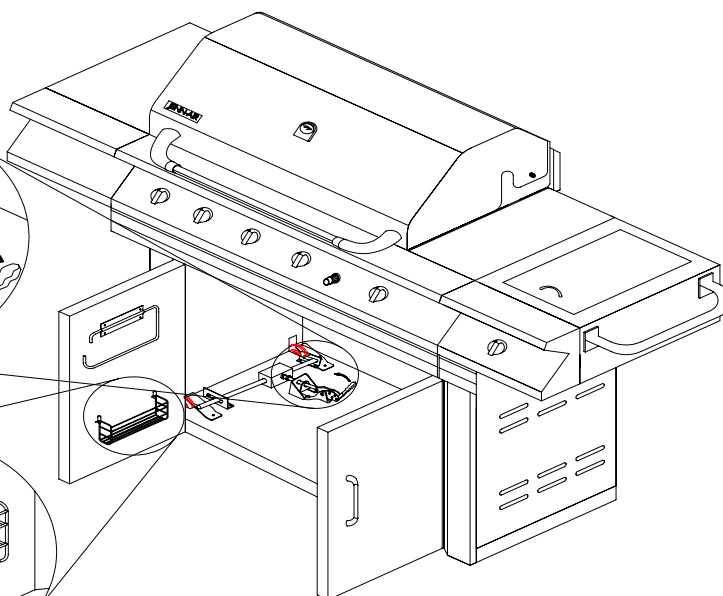
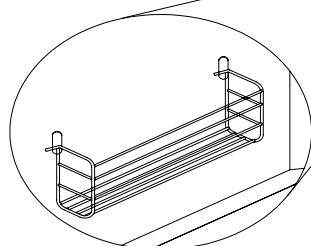

INSTALLATION OF NATURAL GAS REGULATOR

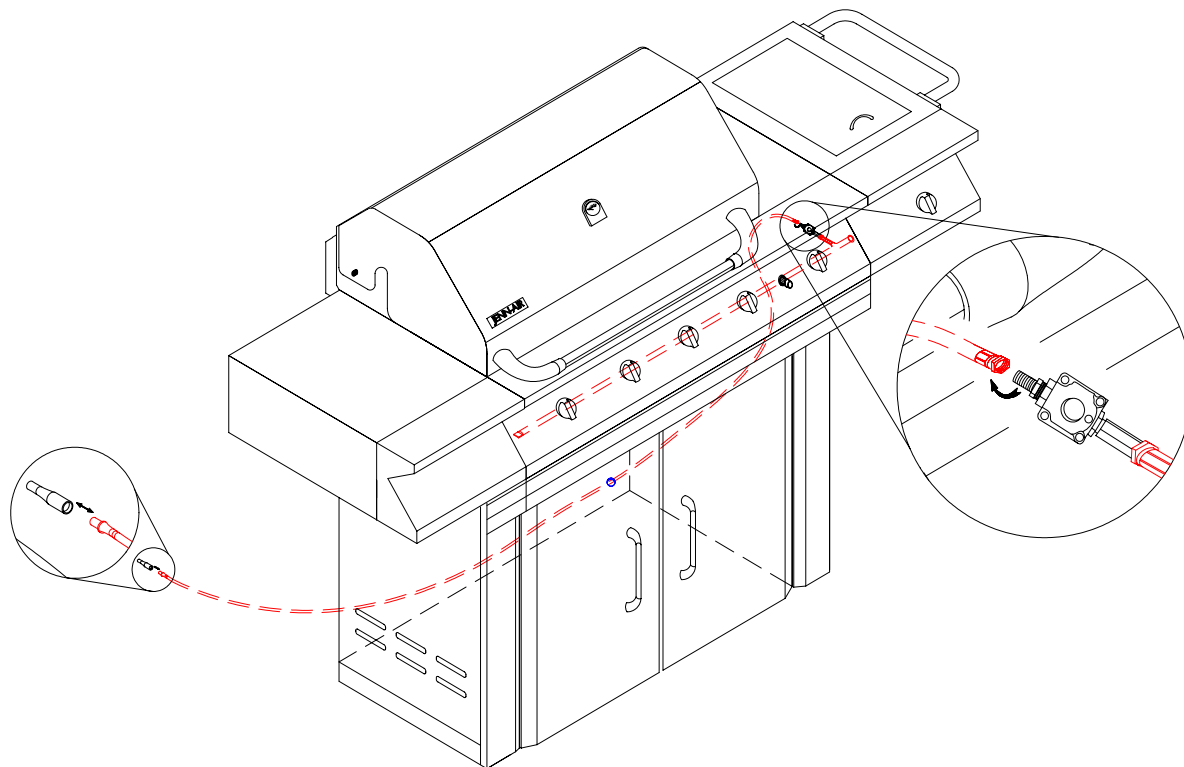

Connect the PVC Gas Hose to the house gas line using the quick-connect fitting.

The Natural Gas regulator has been factory installed. Insert the PVC Gas Hose through the hole in the rear cart panel and attach to the regulator.

GAS HOOK-UP

Only the pressure regulator and hose assembly supplied with the grill should be used. Any replacement pressure regulator and hose assembly must be specified by the grill manufacturer.

Total gas consumption (per hour) of the 720-0100-NG grill with all burners set on "HI":

Main burners	48,000 BTU/Hr.
Rear burners	10,000 BTU/Hr.
Side burner	12,000 BTU/Hr.
Total	70,000 BTU/Hr.

LEAK TESTING

GENERAL

Although gas connections on the grill are leak tested prior to shipment, a complete gas tightness check must be performed at the installation site. Periodically check the whole system for leaks following the procedures listed below.

If the smell of gas is detected at anytime, you should immediately check the entire system for leaks.

BEFORE TESTING

Make sure all packing materials have been removed from the grill, including the burner tie-down straps.

WARNING

Check all gas supply fittings for leaks before each use. Do not use the grill until all connections have been checked and do not leak.

Do not smoke while leak testing.

Never leak test with an open flame.

Make a soap solution of one part liquid detergent and one part water. You will need a spray bottle, brush, or rag to apply the solution to the fittings.

TO TEST

1. Make sure the control valves are in the "OFF" position, and turn on the gas supply.
2. Check all connections from the natural gas regulator and supply valve up to and including the connection to the manifold pipe assembly (the pipe that goes to the burners). Soap bubbles will appear where a leak is present.
3. If a leak is present, immediately turn off the gas supply and tighten leaky fittings.

4. Turn the gas back on and recheck.

Should the gas continue to leak from any of the fittings, turn off the gas supply and contact customer service at 1-800-554-5799.

Only those parts recommended by the manufacturer should be used on the grill. Substitutions will void the warranty.

GAS FLOW CHECK

Each grill burner is tested and adjusted at the factory prior to shipment. However, variations in the local gas supply may make it necessary to adjust the burners.

Flames should be blue and stable with no yellow tips, excessive noise or lifting.

If any of these conditions exist, first check to see if the burner is blocked by dirt, debris, spider webs, etc.

If the burner is free of blockages, you will need to fine-tune the air/gas mixture by moving the adjustment bolt (See the image on page 9).

Remember it is better to make several minor adjustments as opposed to a single large adjustment.

It is handy to keep a spray bottle of soapy water near the shut-off valve of the gas supply line. Spray all the fittings. Bubbles indicate leaks.

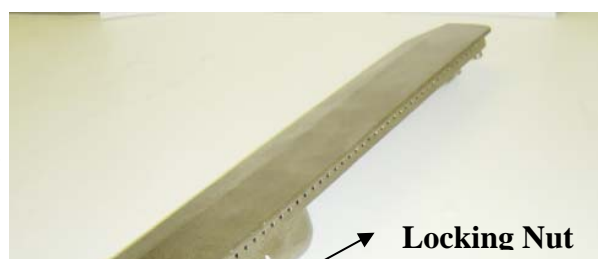

If the flames have yellow tips, loosen the locking nut and move the bolt in a clockwise direction. If the flames are making excessive noise or lifting, loosen the locking nut and turn the bolt in a counter-clockwise direction.

Remember to tighten the locking nut before relighting the burner. If you have any questions regarding flame stability, please contact customer service at 1-800-554-5799.

INSTALLER FINAL CHECK

WARNING

Burner adjustments should only be performed after the burners have cooled.

Always tighten the locking nut before relighting the burner.

2. All internal packaging has been removed.
3. The hose and regulator are properly connected.
4. The unit has been tested and is free of leaks.
5. The gas supply shut off valve has been located.
6. All burners are factory installed.

WARNING

1. The outdoor cooking gas appliance and its individual shutoff valve must be disconnected from the gas supply piping system during any pressure testing of that system at test pressure in excess of ½psi (3.5kpa).
2. The outdoor cooking gas appliance must be isolated from the gas supply piping system by closing its individual manual shutoff valve during any pressure testing of the gas supply piping system at test pressure equal to or less ½psi (3.5kpa)

OPERATING INSTRUCTIONS

GENERAL USE OF THE GRILL AND ROTISSERIE

Each main burner is rated at 12,000 BTU/Hr. The main grill burners encompass the entire cooking area and are side ported to minimize blockage from falling grease and debris. Above the burners are stainless steel flame tamers. The igniter knobs are located on the lower center portion of the valve panel. Each rotary igniter is labeled on the control panel.

USING THE GRILL

Grilling requires high heat for searing and proper browning. Most foods are cooked at a "HI" heat setting for their entire cooking time. However, when grilling large pieces of meat or poultry, it may be necessary to turn the heat to a lower setting after the initial browning. This method cooks the food thoroughly without burning the outside.

Food cooked for a long time or basted with a sugary marinade may need a lower heat setting near the end of its cooking time.

To begin:

1. Make sure the grill has been leak tested and is properly placed.
2. Remove any remaining packing materials.
3. Light the grill burners using the instructions on page 12.
4. Turn the control knob(s) to the "HI" setting, and preheat the grill for 15 minutes. The grill lid should be closed during the preheat period.
5. Place the food on the grill and cook to the desired preparation. If necessary, adjust the heat setting. The control knob may be positioned at any setting between "HI" and "LO".

USING THE ROTISSERIE BURNER

Your grill is capable of performing back burner rotisserie cooking. Light the rear burner as described in the lighting instructions on page 11. Once lit, the rotisserie burner will reach cooking temperature in about 1 minute.

The rotisserie motor is capable of turning up to a 12lb. cut of meat or poultry. The motor slides onto the stainless steel motor mount.

The rotisserie motor must be electrically grounded in accordance with local codes or, in the absence of local codes, with the National Electrical Code, ANSI/NFPA 70-1990.

After its first use, the stainless steel adjacent to the rotisserie burner will most likely turn dark blue. This is a normal property of the non-rusting type stainless steel used on the grill.



WARNING

The rotisserie motor is equipped with a plug and should be plugged directly into a properly grounded receptacle. Do not cut or remove the grounding prong from this plug.

Keep the rotisserie motor cord away from the heated surfaces of the grill. When not in use remove and store the motor in a dry location.

THE ROTISSERIE SKEWER

The skewer for the rotisserie should be assembled into the motor by placing the pointed end into the motor, and then sliding the grooved bushing into the slot at the opposite side of the grill.

The thumbscrew for the grooved bushing should be inside the grill body.

The grill is designed to cook efficiently without the use of lava rocks or briquettes of any kind. Heat is radiated by the stainless steel flame tamers positioned above each burner.

LOADING THE ROTISSERIE SKEWER

1. Screw the bushing onto the skewer rod at the opposite end from the point.
2. Slide and tighten the counter balance apparatus onto the skewer rod approximately 2 to 4in. from the bushing.
3. Slide the first meat fork onto the skewer rod prongs toward the food.
4. Center the product to be cooked on the skewer, and then push the meat forks firmly together.
5. Tighten the wing nuts.
6. It may also be necessary to wrap the food with butcher's string to secure loose portions. Never use nylon or plastic string to wrap the food.
7. Once the food is secure, insert the skewer into the motor.

NOTE

It is normal for the skewer to flex when larger cuts of meat are being cooked.

If the meat scrapes on the cooking grids during any part of the rotation, the cooking grids must be removed.

Adjust the counter balance weight to balance the heavier side of the meat and avoid lopsided rotation of the rotisserie motor.

 <p>CAUTION When using the rotisserie burner, remove the warming rack. High heat from the burner may cause the warming rack to bend.</p>
--

LIGHTING INSTRUCTIONS

BEFORE LIGHTING...

Inspect the gas supply hose prior to turning the gas "ON". If there is evidence of cuts, wear, or abrasion, it must be replaced prior to use.

 <p>WARNING Do not use the grill if the odor of gas is present. Contact customer service at 1-800-554-5799.</p>

Leak check the piping and regulator connections with a soap and water solution before operating the grill (see Leak testing instruction page 8).

Only the pressure regulator supplied with the unit should be used. Never substitute regulators that are not supplied with the grill. If a replacement is necessary, contact the factory for proper replacement.

TO LIGHT THE GRILL BURNER

1. Make sure all the knobs are in the "OFF" position, and then turn on the gas supply.
2. The igniter is built into the valve. To ignite each burner, simply press and turn the control knobs to the "HI" setting. The valve will click as it sends a spark to the pilot flame.
3. If the burner does not light, turn off the gas supply, wait 5 minutes for any excess gas to dissipate and then try again.

FLAME CHARACTERISTICS

Check for proper burner flame characteristics. Each burner is adjusted prior to shipment. However, variations in the local gas supply may make minor adjustments necessary.

Burner flames should be blue and stable with no yellow tips, excessive noise or lifting.

Yellow flames indicate insufficient air. Noisy flames or flames that lift away from the burner indicate too much air (See the "GAS FLOW CHECK" section on page 8).

MATCH LIGHTING

If the burner does light after several attempts, it can be lit with a match.

1. Wait 5 minutes for any accumulated gas to dissipate.
2. Insert a lit extended match or lighter through the cooking grids to the burner.
3. Press and turn the control knob left to the "HI" setting. Continue pressing the knob until the burner ignites.
4. If the burner does not light within 4 seconds, turn the knob off. Wait 5 minutes and try again.

TO LIGHT THE ROTISSERIE BURNER:

1. Open the lid, and press the knob for about 5 seconds without turning it. This will allow time for gas to flow into the rear burner.
2. Turn the knob to the "HI" setting. While turning the knob, press the igniter button to light the rotisserie burner.
3. If the burner does not light, turn the control knob to the "OFF" position.
4. If the igniter does not function, follow the instructions above for match lighting.

<p>Keep a spray bottle of soapy water near the gas supply valve and check the connections before each use.</p>
--

TO MATCH LIGHT THE GRILL

If the burner will not light after several attempts using the control knobs, the burner may be lit with a match.

1. If you have already attempted to light the burner with the igniter, allow 5 minutes for any accumulated gas to dissipate.
2. Insert a lit extended match or lighter through the cooking grids to the burner.
3. Press the control knob and rotate left to the "HI" setting, continue to press the knob until the burner ignites. The burner should light immediately.
4. If the burner does not light within 4 seconds turn the knob to the "OFF" position, wait 5 minutes and try again.

CAUTION

When lighting, keep your face and hands as far away from the grill as possible.

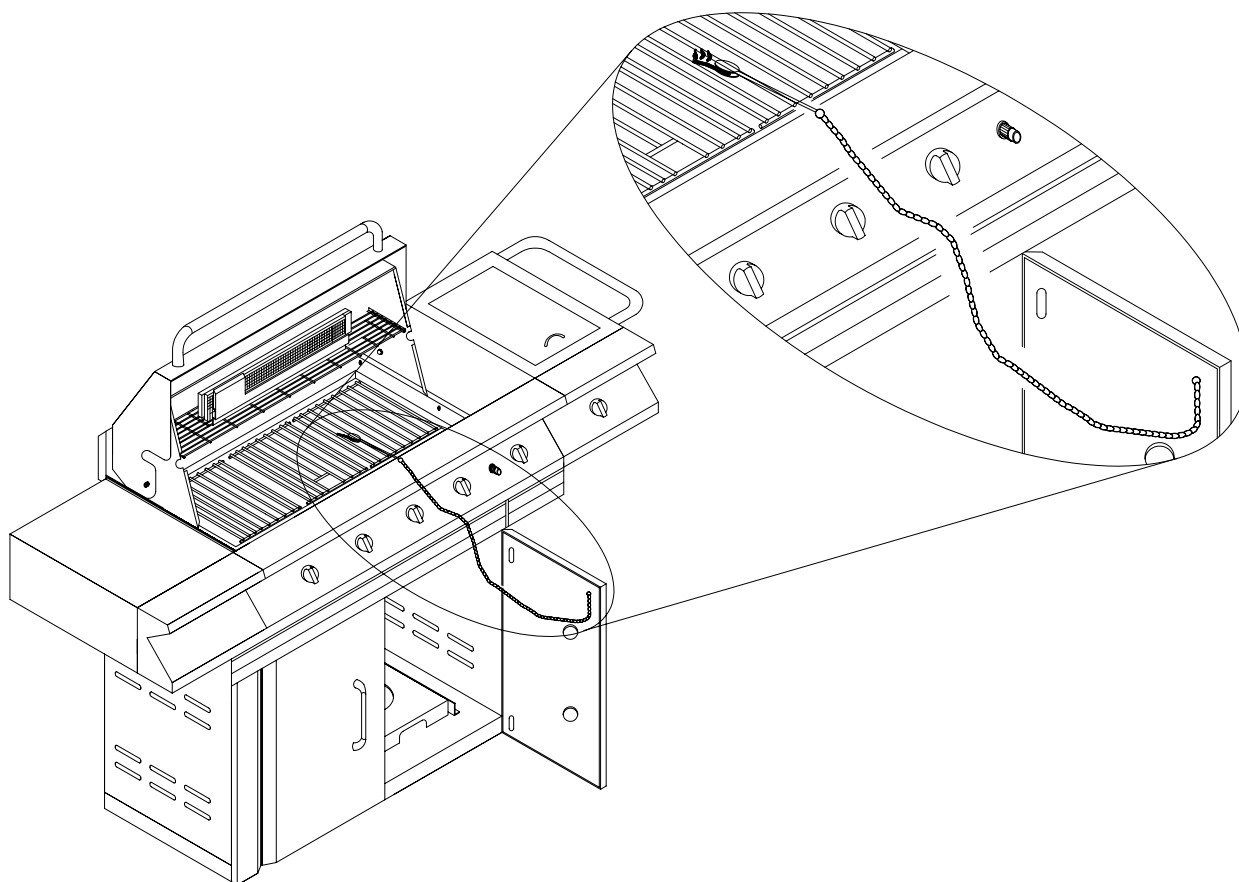

EASY LIGHTING ILLUSTRATIONS

MAIN & SIDE BURNER LIGHTING



1. Open the top cover or lid.



2. Press and turn one of the main or side burner control knobs to the "HI" setting.



3. After the burner is lit, adjust the knob as desired. Multiple attempts may be required to light the grill.

ROTISSERIE BURNER LIGHTING



1. Press and turn the rotisserie knob to the "HI" setting.



2. Press the electric igniter 3 to 4 seconds to light the rotisserie burner.



3. After the burner has been lit, adjust the knob to the desired temperature setting.

USING THE SIDE BURNER

Inspect the gas supply hose prior to turning on the gas. If there is evidence of cuts, wear or abrasion, it must be replaced prior to use. Do not use the side burner if gas odor is present.



WARNING

Always keep your face and body as far away from the burner as possible when lighting.

LIGHTING INSTRUCTIONS

1. Remove any cooking utensils from the burner grate and open the top cover or lid.
2. Push and turn the control knob counterclockwise to the "HI" setting.
3. If the burner does not light, turn the control knob to the "OFF" position.

4. If the smell of gas is detected and the igniter is not functioning, immediately turn the control knob to the "OFF" position.
5. Allow 5 minutes for any accumulated gas to dissipate. If the side burner igniter will not function, follow the match lighting instructions.

MATCH LIGHTING

1. Hold a lit extended match or lighter near the side burner ports.
2. Turn the control knob counterclockwise to the "HI" setting.
3. Rotate the control knob to the desired setting.

CARE & MAINTENANCE OF SIDE BURNER

BURNER CLEANING

Clean the exterior of the burner with a wire brush. Clear any clogged burner ports with a straightened paper clip. Never enlarge the burner ports. Never use a wooden toothpick as it may break off and clog the port.

SIDE BURNER GRATE

The top burner grate is stainless steel. To avoid burns, do not clean the grates while they are hot. While in place, they may be washed with hot, soapy water, rinsed and wiped dry. Never immerse hot grates in water.

STAINLESS STEEL

There are many stainless steel cleaners available. Always use the mildest cleaning procedure first, scrubbing in the direction of the grain. Do not use steel wool as it will scratch the surface.

To touch up noticeable scratches in the stainless steel, sand very lightly with dry 100 grit sand paper in the direction of the grain.

CARE & MAINTENANCE OF THE GRILL

STAINLESS STEEL

The grill is made of non-rusting and non-magnetic stainless steel. There are many stainless steel cleaners available. Always use the mildest cleaning procedure first, scrubbing in the direction of the grain.

To touch up noticeable scratches in the stainless steel, sand very lightly with dry 100 grit emery paper in the direction of the grain.

Grease specks can gather and bake onto the surfaces of the stainless steel, giving the appearance of rust. For removal, use an abrasive pad with a stainless steel cleaner.

GRILL RACK

The easiest way to clean the grill is immediately after cooking is completed, and the flames have been turned off.

Wear a barbecue mitt to protect your hand from the heat and steam.

Scrub the hot grill by dipping a bristle barbecue brush in tap water. Cleaning will be more difficult if the grill is allowed to cool.



CAUTION

Before cleaning, make sure the gas supply and control knobs are in the "OFF" position, and the burners have cooled.

GRILL BURNER CLEANING

1. Turn off the gas supply, and make sure the control knobs are in the "OFF" position.
2. Make certain the grill is cool, and clean the exterior of the burner with a wire brush. Use a metal scraper for stubborn stains.
3. Clear clogged ports with a straightened paper clip. Never use a wooden toothpick. It may break off and clog the port.
4. If insects or other obstructions are blocking the flow of gas to the burner, call customer service at 1-800-554-5799.

GRILL BURNERS

Extreme care should be taken when moving a burner. It must be correctly centered on the orifice before any attempt is made to relight the grill. Frequency of cleaning will depend on how often you use the grill.



WARNING

Failure to properly place the burner over the orifice could cause a fire to occur behind and beneath the valve panel, thereby damaging the grill and making it unsafe to operate.

GRILL BURNER REMOVAL/INSTALLATION

The grill burners are factory installed.

To remove the main burners for cleaning:

1. Locate the cotter pin at the rear of the burner on the bottom side.
2. Remove the cotter pin and lift the burner out of the fire box.

To reinstall the main burners:

3. Insert the burner over the valve assembly (Item# 11 on Page 17).
4. Insert the back of the burner into the hole at the rear of the fire box and reinsert the cotter pin.

GREASE TRAY CLEANING

The grease tray should be emptied, wiped down and washed periodically in a mild detergent and warm water solution.

A small amount of sand or cat litter may be placed in the bottom of the grease tray to absorb the grease. Check the grease tray frequently. Do not allow excess grease to accumulate and flow out of the grease tray.

TROUBLESHOOTING

WARNING

Spiders and insects can nest inside the burners of the grill and disrupt gas flow. This very dangerous condition could cause a fire behind the valve panel, thereby damaging the grill and making it unsafe for operation.

Inspect the grill at least twice a year.

WHEN TO LOOK FOR SPIDERS

You should inspect the burners at least twice a year or immediately after any of the following conditions occur:

1. The smell of gas in conjunction with burner flames appearing yellow.
2. The grill does not reach temperature.
3. The grill heats unevenly.
4. The burners make popping noises.

BEFORE CALLING FOR SERVICE

If the grill does not function properly, use the following checklist before contacting your dealer for service. You may save yourself the cost of a service call.

PROBLEMS

Grill will not light when the control knob is rotated.

Burner flame is yellow or orange, in conjunction with gas odor.

Low heat with the control knob on the "HI" setting.

WHAT TO DO

- Clean wire(s) and/or electrode with rubbing alcohol and a clean swab. Wipe with a dry cloth.
- Make sure the wire is connected to the electrode assembly.
- Check to see if the other burners operate. If so, check the gas orifice on the malfunctioning burner for an obstruction.
- Call customer service at 1-800-554-5799.
- Check to see if the fuel hose is bent or kinked.
- Make sure the grill area is clear of dust.
- Check your gas regulator and pressure.
- Make sure the burner and orifice are clean.

EXPLODED VIEW

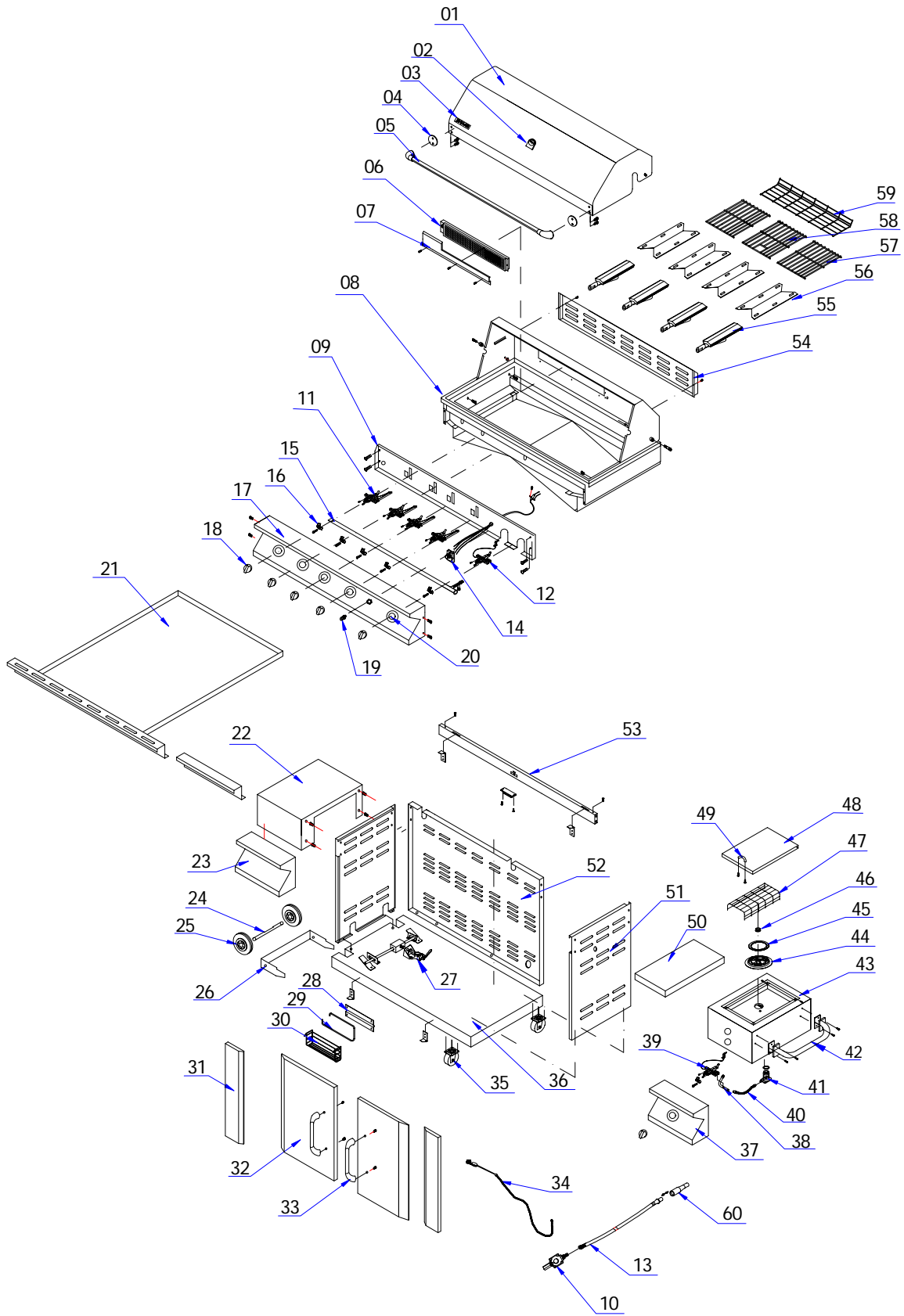

MODEL720-0100-NG PARTS LIST

REF#	DESCRIPTION	QTY	REF#	DESCRIPTION	QTY
01	Lid, Front	1	31	Front Panel	2
02	Heat Indicator	1	32	Front Door	2
03	Name Plate	1	33	Door Handle	2
04	Heat Insulating spacer	2	34	Lighting Rod	1
05	Handle Assembly, Lid	1	35	3" Caster	2
06	Infrared Burner	1	36	Bottom Panel	1
07	Gas Collector, Rear Burner	1	37	Front Panel, Side Burner	1
08	Bowl Assembly	1	38	Gas Hose Connector, Side Burner	1
09	Front Baffle	1	39	Gas Valve, Side Burner	1
10	Regulator, NG	1	40	Gas Pipe, Side Burner	1
11	Gas Valve, Main Burner	4	41	Orifice Base	1
12	Gas Valve, Rear Burner	1	42	Push Bar	1
13	NG PVC Gas Hose	1	43	Bowl Assembly, Side Burner	1
14	Electronic Ignition	1	44	Side Burner Body	1
15	Manifold	1	45	Side Burner Ring	1
16	Manifold Retainer Bracket	6	46	Side Burner Head	1
17	Control Panel	1	47	Cooking Grid, Side Burner	1
18	Control Knob	6	48	Lid, Side Burner	1
19	Electric Ignition Button	1	49	Lid Handle, Side Burner	1
20	Control Panel Seat	6	50	Spacer	1
21	Grease Tray	1	51	Side Panel, Cart	2
22	Side Shelf	1	52	Back Panel, Cart	1
23	Front Panel, Side Shelf	1	53	Cart Frame	1
24	Caster Axle	1	54	Rear Baffle, Infrared Burner	1
25	6"Caster	2	55	Main Burner	4
26	Caster Bracket	1	56	Flame Tamer	4
27	Brake	1	57	Cooking Grid	2
28	Tower Rack Bracket	1	58	Cooking Grid With Hole	1
29	Tower Rack	1	59	Warming Rack	1
30	Spice Tray	1	60	Gas Hose Adaptor	1

GRILLING HINTS

The preparation of meat, whether rare, medium, or well done, is affected to a large degree by the thickness of the cut.

The cooking time is affected by the type of meat, the size and shape of the cut, the temperature of the meat when cooking begins, and the degree of preparation desired.

It is recommended that meat be defrosted overnight in the refrigerator as opposed to a microwave. This generally yields a juicier cut of meat.

Use a spatula instead of tongs or a fork to turn the meat. A spatula will not puncture the meat and let the juices run out.

To get the juiciest meat, add seasoning or salt after cooking is finished and turn the meat only once during cooking. Juices are lost when the meat is turned several times. Turn the meat just after the juices begin to bubble to the surface.

Trim excess fat from the meat before cooking. To prevent steaks or chops from curling during cooking, slit the fat around the edges at 2 inch intervals.



WARNING

Do not leave the grill unattended while cooking.

GRILL COOKING CHART

FOOD	WEIGHT OR THICKNESS	FLAME SIZE	APPROXIMATE TIME	SPECIAL INSTRUCTIONS AND TIPS
VEGETABLES				Slice. Dot with butter or margarine. Wrap in heavy-duty foil. Grill, turning occasionally.
Fresh Beets Carrots Turnips		Medium	12 to 20 minutes	Grill, turning once. Brush occasionally with melted butter or margarine.
Onion	1/2 inch slices	Medium	8 to 20 minutes	Season with Italian dressing, butter, or margarine.
Potatoes Sweet	Whole	Medium	40 to 60 minutes	Wrap individually in heavy-duty foil. Grill, rotating occasionally.
White	6 to 8 ounces	High	45 to 60 minutes	
Frozen Asparagus Peas Green beans Sprouts Broccoli Brussels		Medium	15 to 30 minutes	Dot with butter or margarine. Wrap in heavy-duty foil. Grill, turning occasionally.
French fries		Medium	15 to 30 minutes	Place in aluminum foil pan. Grill, stirring occasionally.

FOOD	WEIGHT OR THICKNESS	FLAME SIZE	APPROXIMATE TIME	SPECIAL INSTRUCTIONS AND TIPS
MEATS BEEF				
Hamburgers	1/2 to 3/4 inch	Medium	10 to 18 minutes	Grill, turning once when juices rise to the surface. Do not leave hamburgers unattended. A flare-up could occur quickly.
Tenderloin, Porterhouse, Rib eye		High	8 to 15 minutes	
Rare	1 inch	High	8 to 14 minutes	Remove excess fat from edges. Slash remaining fat at 2-inch intervals. Grill, turning once.
Medium	1-1/2 inch 1 inch 1-1/2 inch	High Medium to High	11 to 18 minutes 12 to 22 minutes 16 to 27 minutes	
Well-done	1 inch 1-1/2 inches	Medium Medium	18 to 30 minutes 16 to 35 minutes	
Lamb Chops & Steaks Rare	1 inch	High	10 to 15 minutes	
	1-1/2 inch	High	14 to 18 minutes	Remove excess fat from edges. Slash remaining fat at 2 inch intervals. Grill, turning once.
Medium	1 inch 1-1/2 inch	Medium to High	13 to 20 minutes 18 to 25 minutes	
Well-done	1 inch	Medium	17 to 30 minutes	
Pork Chops	1 inch	Medium	20 to 30 minutes	Remove excess fat from edges. Slash remaining fat at 2 inch intervals. Grill, turning once. Cook well done.
Well-done	1-1/2 inches	Medium	30 to 40 minutes	
Ribs Pork		Medium	30 to 40 minutes	Grill, turning occasionally. During last few minutes, brush with barbecue sauce, turning several times.
Ham steaks (precooked)	1/2 inch slices	High	4 to 8 minutes	Remove excess fat from edges. Slash remaining fat at 2 inch intervals. Grill, turning once.
Hot dogs		Medium	5 to 10 minutes	Slit skin. Grill, turning once.
POULTRY Broiler/fryer	2 to 3 pounds	Low or	1 to 1-1/2 hours	Place skin side up. Grill, turning and brushing frequently with melted butter, margarine, oil or marinade.

FOOD	WEIGHT OR THICKNESS	FLAME SIZE	APPROXIMATE TIME	SPECIAL INSTRUCTIONS AND TIPS
Breasts well-done		Medium	30 to 45 minutes	Marinate with Italian dressing
FISH AND SEAFOOD				
Steaks Halibut Salmon Swordfish	3/4 to 1 inch	Medium to High	8 to 15 minutes	Grill, turning once. Brush with Melted butter, margarine or oil To keep moist.
Whole Catfish	4 to 8 ounces	Medium to	12 to 20 minutes	Grill turning once. Brush with melted butter, margarine or oil.
Rainbow trout		High		Brush with melted butter and lemon juice.

GRILL RECIPES

BBQ SALMON

2 large salmon steaks
2 tbs. oil
Salt & pepper
2 oz. thin bacon slices
2 tbs. butter
1 tbs. lemon juice
Sprig of parsley
Lemon wedges

*You can substitute catfish, halibut or cod for salmon.

Preheat the BBQ

Brush the steaks with oil and season with salt and pepper. Place on BBQ grill and cook for 10 minutes, turning steaks over halfway through cooking time.

Meanwhile fry the bacon in a pan on the side burner. Drain on paper towels. Melt the butter in a small saucepan taking care not to discolor it. Arrange the fish and bacon on serving plates. Pour the butter over and sprinkle with lemon juice. Garnish with parsley sprigs and lemon wedges. Serve with boiled potatoes in butter and sprinkled with parsley.

BAKED CHILI CORN

6 medium ears corn, husked
3 tbs. butter or margarine, melted
Dash ground cumin
Dash ground coriander

About ½ hour before cooking, turn the grill on for butter. Place each ear on a heavy-duty foil. In a bowl, combine remaining ingredients. Mix well. Brush 1-1/2 tsp. butter mixture over each ear. Close foil and fold up ends to seal. Place on grill. Cook, turning packets occasionally 10 to 12 minutes or until cooked through.

TANGY SEAFOOD KABOBS

1 lb. Large shrimp, shelled & divined
¾ Lbs. Sea scallops
2/3 c. chili sauce
¼ c. cider vinegar
3 tbs. Chopped parsley
1 tbs. Vegetable oil
1 tbs. Worcestershire sauce
½ tsp. Prepared horseradish
1 clove garlic, minced
1 20 oz. Can pineapple chunks in juice drained.

In medium bowl, combine shrimp and scallops. In small bowl, combine chili sauce and next six ingredients. Pour over seafood. Toss to coat. Cover, refrigerate 2 hours.

Half-hour before cooking, turn the burner to the grill on high. Drain seafood-reserving marinade. On each of twelve 10" skewers, thread 2 shrimps and 2 scallops, alternating with pineapple chunks. Place skewers on grill. Cook 7-10 minutes, basting and turning often.

PORK CHOPS

4 pork chops
Marinade
1 large onion
2 tbs. lemon juice or vinegar
2 tbs. oil
½ tsp. freshly ground black pepper.
1 tsp. sugar
½ tps. paprika
1 clover garlic
Peel, grate onion, and add rest of the ingredients except the pork chops. Mix well. Pour over chops and marinate one hour in a cool place. Turn the BBQ grill on high. Heat 10 minutes. BBQ the chops brushing with the marinade occasionally. Serve with mixed salad, dressed with vinaigrette flavored with fresh dill.

BARBECUED POTATOES and CHEESE

1 -1/2 cups shredded cheddar cheese
1 can (10-3/4 oz.) condensed cream of mushroom soup
1/3 cup milk
2 tbs barbecue sauce
¼ tsp. oregano
¼ tsp. salt
1/8 tsp. pepper
4 cups thinly sliced potatoes (4 medium-sized potatoes)

Preheat grill. Combine cheese, condensed soup, milk, BBQ sauce, oregano, salt and pepper in a large mixing bowl. Stir in potatoes until well coated. Turn into well-buttered 1-1/2 quart rectangular baking dish. Cover dish with aluminum foil. Bake covered 25 minutes on medium with the lid of your BBQ grill closed. Remove foil and continue baking 15 minutes longer or until potatoes are tender. Let stand 5 minutes before serving.

BARBECUED LONDON BROIL

4 to 6 servings
¾ c. Italian dressing

1 tsp. Worcestershire sauce
1 tsp. Dry mustard
¼ tsp. Thyme, crushed
1 medium onion, sliced
1 pound flank steak, scoured
2 tbs. Butter, melted

Combine first 4 ingredients, add onion and marinade flank steak with it. Refrigerate at least 4 hours or overnight. Remove steak and grill on preheated BBQ grill. Grill 5 to 7 minutes on each side basting frequently with the marinade. In the meantime sauté onions from the marinade in butter in a skillet on grill side burner for 3 minutes. To serve, slice steak diagonally into thin slices, sprinkle onions over top. Garnish with vegetable kabobs.

VEGETABLE KABOBS

3 medium-size zucchini
12 cherry tomatoes
12 fresh mushrooms
Grated parmesan cheese

Parboil whole zucchini 5 minutes on grill side burner or until just tender. Drain and cut into ½ inch slices. Thread zucchini, tomatoes and mushrooms alternately on each of six skewers. Brush with marinade made of Italian dressing, Worcestershire sauce, mustard and thyme. Grill 5 to 7 minutes turning and basting occasionally. Sprinkle liberally with Parmesan cheese.

FAJITAS

1-1/2 lb. flank steak or boned chicken breasts
2 tbs. oil
½ cup lime juice
½ tsp. salt
½ tsp. celery salt
¼ tsp. garlic powder
½ tsp. pepper
¼ tsp. oregano
¼ tsp. cumin
Flour tortillas
Lemon

Pound flank steak to ¼ inch thickness or flatten chicken breasts. Mix oil, lime juice and seasonings in a zip lock bag. Add meat and shake bag to coat the meat. Refrigerate overnight or at least 6 to 8 hours. Wrap tortillas in foil. Remove meat from marinade. Cook on a pre-heated gas grill for 5 to 8 minutes on each side. While meat is cooking,

heat tortillas on grill. Slice meat across grain in thin slices. Place on hot platter. Squeeze lemon juice over. Wrap meat and any of the following toppings in tortillas: chopped tomatoes, guacamole, sour cream, and taco sauce.

BEEF AND LAMB KABOBS

Serve 4

½ lb. boneless sirloin or beef cut into 1" cubes

½ lb. boneless loin of lamb cut into 1" cubes

2/3 c. water, divided

¼ c. chopped onion

2 tbs. soy sauce

¼ c. vegetable oil, divided

1 tbs. dark brown sugar

1 tbs. fresh lemon juice

2 cloves garlic, minced

¼ tsp. ground cumin

¼ tsp. ground coriander

¼ tsp. ground turmeric

1/8 tsp. ground red pepper

1/8 tsp. ground ginger

1 red pepper cut into chunks

1 large banana, cut into chunks

8 small mushrooms

1/3 c. smooth peanut butter

In blender, process 1/3 c. water, onion, soy sauce, 2 tsp. oil and the next 8 ingredients until smooth. Pour over meat cubes and marinate about 4 hours, turning occasionally. Drain and reserve marinade. On to four 12" skewers alternately thread meat, pepper, banana and mushrooms. Preheat grill. Brush the kabobs with oil. Grill 7-8 minutes each side.

Bring marinade to boil on the side burner in a saucepan. Add remaining 1/3 c. water and peanut butter. Stir to blend. Heat through. If sauce gets too thick, add 1 tbs. water. Serve sauce with kabobs.

EGGPLANT CAVIAR

1 large eggplant

2 tbs. olive oil

2 tbs. wine vinegar

2 tbs. finely chopped onion

½ clove garlic, minced

1 medium tomato, chopped salt and pepper

Roast eggplant on gas grill over medium flame, turning occasionally until thoroughly cooked. This may take 30 minutes. Remove from grill and cool for handling. Strip off the skin and chop eggplant finely. Add all the seasonings. Chill thoroughly and serve on toast.

CHICKEN TANDOORI STYLE

8 large chicken thighs or drumsticks

1 c. plain nonfat yogurt

½ c. lemon juice

2 tsp. salt

½ tsp. cayenne

½ tsp. black pepper

½ tsp. crushed garlic

½ tsp. grated ginger

1 tbs. corn oil

Combine all the ingredients in a large mixing bowl and marinate the chicken for 8 hours in the refrigerator. Drain the chicken and spread on the spit running the rod on the fleshier side of the bone.

Bake using the rotisserie. Cook on medium high heat for 40 minutes basting occasionally with the remainder of the marinade mixture. Serve with sliced onions and lemon wedges.

SPARE RIBS

Marinade:

1 c. soy sauce

½ c. honey

½ c. vinegar

½ c. dry sherry

2 tsp. chopped garlic

2 tsp. sugar

1 c. water

1 chicken bouillon cube

1 can beer for basting sauce

Marinate ribs for 3 hours. Use marinade for basting by adding beer to it. Place pan under the ribs and baste frequently. To cook ribs select lean, meaty ribs and accordion pleat them with your spit. Slide four-prong meat hook down the length of spit and tighten. At the beginning of the rack and to its center, penetrate the second rib with the pointed end of the spit and push it between the meat. Skip a couple and continue the process until the entire rack is accordion pleated. Fasten the second meat hook into the rack. Turn rotisserie burner on high. Bake using the rotisserie for 50 minutes or until done.

PORK ROAST

Apple cider vinegar basting sauce:

1 c. apple cider vinegar

6 oz. water

½ stick butter

Salt, pepper, parsley and garlic seasoning

2 oz. lemon juice

10 lbs. pork roast

Time: 1-1/2 hours to 2 hours
Bring pork to room temperature before placing it on the rotisserie spit rod. Place on the rod and test for balance. Light rotisseries burner. Turn control knob to high. Use the above basting sauce for rotisserie baking

TURKEY

12 lb. turkey

Beer basting sauce:

1 can beer

12 oz. water

1 stick butter

1 tsp. salt

1 tsp. pepper

½ tsp. garlic flakes

1 tsp. parsley

Thaw the bird completely. Wash inside out. Securely tie the legs and wings before placing the turkey on the rotisserie spit rod. Light rotisseries burner. Turn to high. Combine all the ingredients for basting sauce in a shallow pan. Place it under the turkey 15 to 20 minutes. Cook for approximately 3 hours. The basting sauce combined with turkey drippings makes delicious gravy.

LIMITED WARRANTY

MODEL #720-0100-NG

STAINLESS STEEL OUTDOOR GAS GRILL

Nexgrill Industries, Inc. warrants to the original consumer-purchaser of each Jenn-Air Outdoor Gas Grill that when subject to normal residential use, it is free from defects in workmanship and materials for the periods specified below. This warranty excludes grills used in rental or commercial applications.

<u>Component</u>	<u>Warranty Period</u>
Cast Brass Burners:	Lifetime
Stainless Steel Flame Tamer:	Lifetime
Stainless Steel Cooking Grids:	Lifetime
Valves and Hose Regulator:	1 Year
Igniter and Related Parts:	1 Year
All Stainless Steel Parts:	Lifetime

Our obligation under this warranty is limited to repair or replacement, at our option, of the product during the warranty period. The extent of any liability of Nexgrill Industries, Inc. under this warranty is limited to repair or replacement. This warranty does not cover normal wear of parts, discoloration of the stainless steel parts, or damage resulting from any of the following: negligent use or misuse of the product, improper use of fuel/gas supply, use contrary to operating instructions, or alteration by any person other than our factory service center. The warranty period is not extended by such repair or replacement.

Product repair as provided under this warranty is your exclusive remedy. Nexgrill Industries, Inc. shall not be liable for any incidental or consequential damages for breach of any express or implied warranty on its products. Except to the extent prohibited by applicable law, any implied warranty of merchantability or fitness for a particular purpose on this product is limited to the duration of the above warranty. Some states do not allow the exclusion or limitation of incidental or consequential damages, or allow limitations on how long an implied warranty lasts, so the above limitations or exclusions may not apply to you. This warranty gives you specific legal rights, and you may have other rights, which vary from state to state.

WARRANTY CLAIM PROCEDURE

If you require service or parts for your grill, please contact our Warranty Service Center for factory direct assistance. Our hours of operation are 7 AM to 6 PM PST Monday to Friday, 8 AM to 12 PM PST on Saturday. Our telephone number is 1-800-554-5799, fax number 1-800-598-8829. Please direct all correspondence to: Nexgrill Industries, Inc., 145 Brea Canyon Road, Walnut, California, 91789, ATTN: Warranty Service Center.

*Jenn-Air is a trademark of the Maytag Corporation and is used under license to Lowe's Company Inc.

Printed In China