

This Owner's Manual is provided and hosted by [Appliance Factory Parts](#).



# Charbroil 4632241 Owner's Manual

[Shop genuine replacement parts for Charbroil 4632241](#)



[Find Your Charbroil Grill Parts - Select From 3592 Models](#)

----- Manual continues below -----

# ASSEMBLY, USE AND CARE MANUAL

4632241

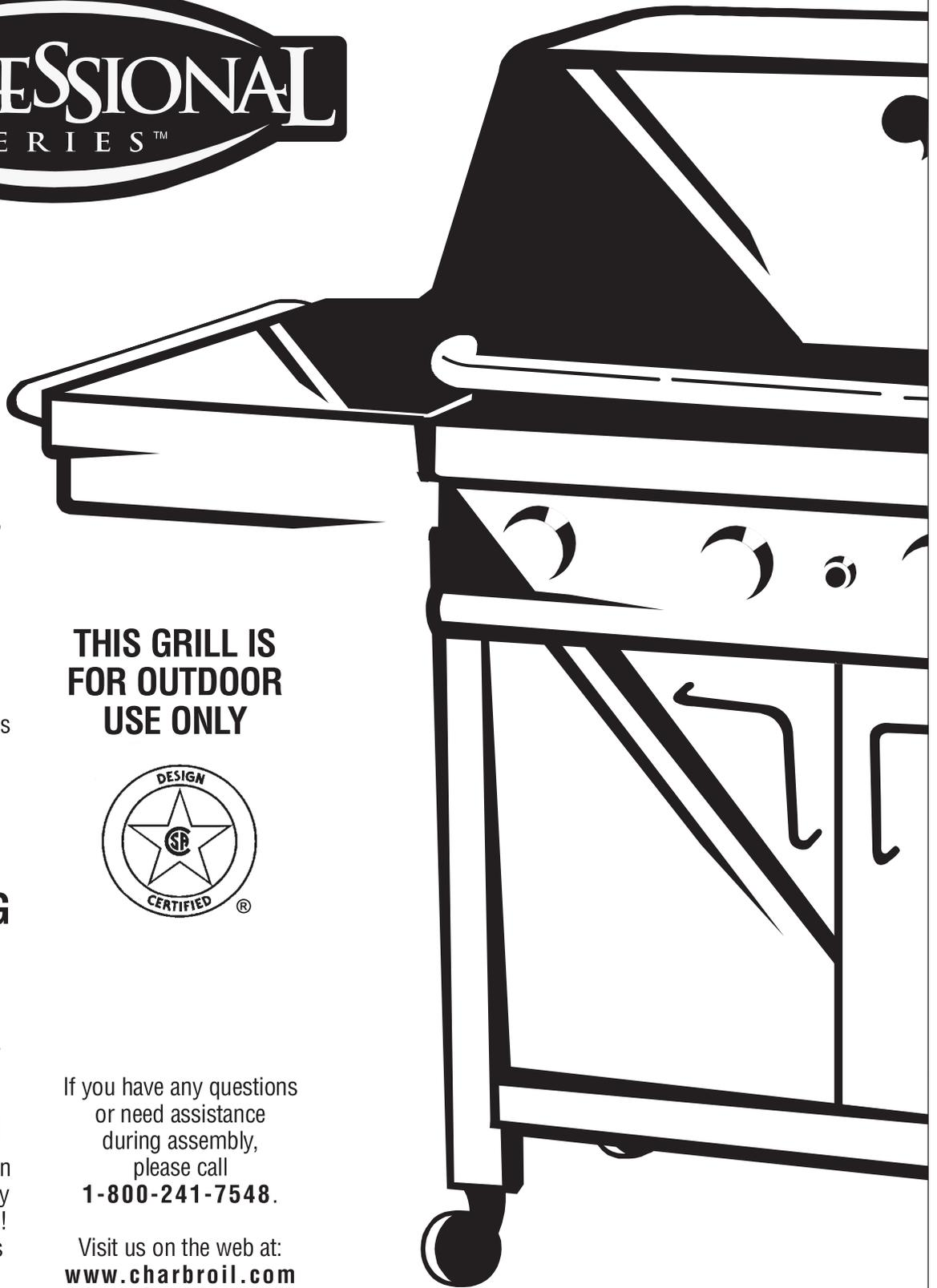

## CAUTION:

Read and follow all safety statements, assembly instructions, and use and care directions before attempting to assemble and cook.

## INSTALLER/ ASSEMBLER:

Leave these instructions with consumer.

## CONSUMER:

Keep this manual for future reference.

## ⚠️ WARNING

Failure to follow all manufacturer's instructions could result in serious personal injury and/or property damage.

## ⚠️ CAUTION

Some parts may contain sharp edges - especially as noted in the manual! Wear protective gloves if necessary.

**THIS GRILL IS  
FOR OUTDOOR  
USE ONLY**



If you have any questions or need assistance during assembly, please call

**1-800-241-7548.**

Visit us on the web at:  
**[www.charbroil.com](http://www.charbroil.com)**

4632241 / 0-P47F3A (01-16-02)

## **WARNING**

### FOR YOUR SAFETY

1. Do not store or use gasoline or other flammable vapors and liquids in the vicinity of this or any other appliance.
2. An LP Tank not connected for use shall not be stored in the vicinity of this or any other appliance.

### FOR YOUR SAFETY

If you smell gas:

1. Shut off gas to the appliance.
2. Extinguish any open flame.
3. Open lid.
4. If odor continues, immediately call your gas supplier or your fire department.

### Call Grill Service Center For Help And Parts

- If you need help or warranty parts call ☎1-800-241-7548, or send a FAX to 1-706-576-6355.  
Business hours: Open 24 hours - Seven days a week.
- To order non-warranty replacement parts or accessories (*grill cover, cleaners, paint*) call 1-800-993-2677 or send a FAX to 1-706-565-2121.

### Important: Fill out Warranty Information below

#### Warranty Information

Model Number \_\_\_\_\_

Lot Number (on carton label) \_\_\_\_\_

Serial Number \_\_\_\_\_

Date Purchased \_\_\_\_\_

## **CAUTION**

- For residential use only. Do not use for commercial cooking.

### Installation Safety Precautions

- This grill is designed for natural gas use at 7 inch water column supply pressure. Verify supply pressure with your local gas company. **Not for use with LP gas.**
- Grill installation must conform with local codes, or in their absence, with **National Fuel Gas Code, NFPA 54 / ANSI Z223.1**. Handling and storage of LP cylinders must conform to LP Gas Code **NFPA/ANSI 58**. Grill is not for use in or on recreational vehicles and/or boats.
- All electrical accessories (such as rotisserie) must be electrically grounded in accordance with local codes, or **National Electrical Code, ANSI / NFPA 70**. Keep any electrical cords and/or fuel supply hoses away from any hot surfaces.
- This grill is safety certified for use in the United States only. Do not modify for use in any other location. Modification will result in a safety hazard.

### Safety Symbols

- The symbols and boxes shown below explain what each heading means. Read and follow all of the messages found throughout the manual.

## **DANGER**

- **DANGER:** Indicates an imminently hazardous situation which, if not avoided, will result in death or serious injury.

## **WARNING**

- **WARNING:** Be alert to the possibility of serious bodily injury if the instructions are not followed. Be sure to read and carefully follow all of the messages.

## **CAUTION**

- **CAUTION:** Indicates a potentially hazardous situation which, if not avoided, may result in minor or moderate injury.

## Table of Contents

For Your Safety .....	2
Call Grill Service Center For Help And Parts .....	2
Installation Safety Precautions .....	2
Safety Symbols .....	2
Table of Contents .....	3
Warranty .....	3
Before Beginning Assembly .....	4
Parts List .....	4
Exploded View .....	5
Assembly .....	6-9
Use and Care .....	9-14
Storing Your Grill .....	13
Indirect Cooking .....	14
Food Safety .....	14
Troubleshooting .....	15

## Warranty

Char-Broil warrants to the original consumer-purchaser that this product shall be free from defects in workmanship and materials under normal and reasonable use and correct assembly (if assembled by consumer-purchaser), from date of purchase.

**Stainless steel and die cast parts - 99 years**  
**Electronic ignition and burners - 10 years**  
**Remaining parts - 2 years**

Char-Broil will, at its option, refinish or replace any product or part found to be defective during the warranty period. Char-Broil will require you to return the part(s) claimed to be defective, for its inspection, freight or postage prepaid.

If you wish to obtain performance of any obligation under this limited warranty, you should write to:

**CHAR-BROIL**  
**Consumer Warranty / P.O. Box 1240**  
**Columbus, GA 31902-1240**

Char-Broil may require reasonable proof of purchase and we suggest you keep your receipt. In the state of California only, if refinishing or replacement of the product is not commercially practicable, the retailer selling this product or Char-Broil will refund the purchase price paid for the product, less the amount directly attributable to use by the original consumer-purchaser prior to discovery of the nonconformity. In addition, in the state of California only, you may take the product to the retail establishment from which it was purchased or to any retail establishment selling this product in order to obtain performance under this warranty.

This warranty does not include the cost on any inconvenience or property damage due to failure of the product and does not cover damage due to misuse, abuse, accident, damage arising out of transportation of the product, or damage incurred through commercial use of the product. This express warranty is the sole warranty given by the manufacturer and is in lieu of all other warranties, express or implied, including implied warranty of merchantability or fitness for a particular purpose. Neither Char-Broil dealers nor the retail establishment selling this product has any authority to make any warranties or to promise remedies in addition to or inconsistent with those stated above. Char-Broil's maximum liability, in any event, shall not exceed the purchase price of the product paid by the original consumer-purchaser. Some states do not allow the exclusion or limitation of incidental or consequential damages. So the above limitations or exclusions may not apply to you. This warranty gives you specific legal rights and may also have other rights which vary from state to state.

## Before Beginning Assembly

- Necessary tools for assembly of your grill include: Phillips® screwdriver, pliers and adjustable wrench.

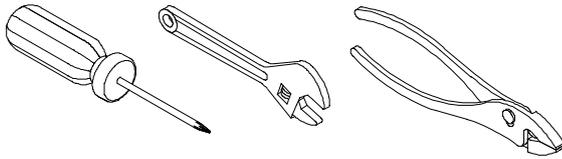

Certified Grill Parts And Accessories®, Char-Broil and Design®, Char-Broil (Gas Grill Briquettes)®, Char-Diamonds®, Cooking Zone and Design®, Diamond Flame®, Executive Chef®, Faststart®, Flare Fighter®, FlavorMaster®, Gas Grill Silhouette and Design®, H2O Smoker®, Lava Flame®, MasterFlame®, MasterFlame Precision Cooking System®, PowerSpark®, Quantum®, VIP®, PrecisionFlame and Design®, Sierra®, and TruFlame® are registered Trademarks of the W.C. Bradley Company. Thermos® is a registered trademark of the Thermos Company and its affiliates.

Artisan Collection by Char-Broil™, C3 and Design™, Char-Broil and Design™, Flame Design™, FlavorTents™, Grill 2 Go™, Grillin' Stick™, Keeper of the Flame™, Keepers of the Flame™, Natural Grip™, Outdoor Cooking Collection and Design™, Patio Bistro™, PrecisionFlame™, Pro-Check™, QuickSet Grills and Design™, SmokerTents™, The Big Easy™, The Minute Grill™, The Edge™, The Tuscan Collection™, and The Urban Grill™ are Trademarks of the W.C. Bradley Company. Universal Grill Parts and Design™ is a trademark of the Thermos Company and its affiliates.

Protected under one or more of the following U.S. Patents: 4,598,692; 4,624,240; 4,747,391; 4,747,391; 4,817,583; 4,924,846; 4,989,579; 5,003,960; 5,076,256; 5,076,257; 5,090,398; 5,109,834; 5,224,676; 5,277,106; 5,421,319; 5,441,226; 5,452,707; 5,458,309; 5,566,606; 5,566,606; 5,579,755; 5,582,094; 5,613,486; 5,649,475; 5,706,797; 5,711,663; 5,765,543; 5,931,149; 5,996,573; 6,095,132; 6,135,104; 6,279,566; D282,619; D339,714; D341,292; D343,337; D358,059; D361,466; D364,535; D372,637; D373,701; D377,735; D383,035; D397,910; D405,643; D405,643; D406,005; D406,009; D413,043; D413,229; D413,229; D414,982; D415,388; D416,164; D416,441; D416,441; D417,587; D422,516; D423,274; D423,876; D428,303; D435,396; D436,004; D438,059; D438,060; D438,427; D439,110; D442,505; D443,179; D443,354; D447,384; D447,385; D447,909; D448,610; D448,614; D448,615; D448,616; D448,975; and D449,492. Other Patents Pending.

## Parts List - 4632241

Key	Qty	Description	Part #
A	1	Lid	P0198A
B	1	Heat Indicator	P0616A
C	1	Curved Stainless Steel Handle	P0269A
D	1	Name Plate - Professional Series	P0478A
E	1	Warming Rack	P1534B
F	2	Cooking Grid - Stainless Steel	P1662A
G	4	Flame Tamer	P1744A
H	4	Burner	P2056A
I	1	Burner Bracket	P2239A
J	4	Gas Collector Box with Electrode	P2623B
K	1	Electric Wire Set	P2615A
L	1	Electric Ignitor (4 port)	P2503G
M	1	Back Burner	P1947A
N	1	Back Burner Frame	P80F1A
O	1	Bowl Side Panel, Left	P0786B
P	1	Bowl Side Panel, Right	P0787B
Q	1	Bowl Front Panel	P0797A
R	1	Bowl Rear Panel	P0798A
S	1	Grease Draining Tray	P2753A
T	1	Grease Receptacle	P2717C
U	1	Gas Manifold	P5050A
V	3	Gas Valve for Main Burner	P32D7A
W	1	Gas Valve for Back Burner	P32E1A
X	1	Spark Electrode	P2515A
Y	1	Gas Tube	P3512B
Z	1	Heat Shield for Control Panel	P2997A
AA	1	Control Panel	P2998B
BB	4	Control Knob (Main Burner)	P3434A
CC	1	Control Knob (Back Burner)	P3434B
DD	5	Control Knob Seat	P3433A
EE	5	Spring	P55G7A
FF	1	Side Shelf, Left	P1173A
GG	1	Side Shelf, Right	P1171A
HH	2	Bracket for Side Shelf, LR/RF	P1423C
II	2	Bracket for Side Shelf, LF/RR	P1423D
JJ	1	Shelf Trim Plate, Right	P7427C
KK	1	Shelf trim Plate, Left	P7428C
LL	2	Side Shelf Handle	P0268A
MM	1	Bottom Shelf	P1071B
NN	2	Bowl Support Bracket	P1343B
OO	1	Side Cart Leg, LF	P0859A
PP	1	Side Cart Leg, LR	P0859B
QQ	1	Side Cart Leg, RF	P0859C
RR	1	Side Cart Leg, RR	P0859D
SS	2	Cart Side Panel	P4318A
TT	1	Cart Rear Panel	P4318B
UU	1	Front Door, Left	P4355A
VV	1	Front Door, Right	P4355B
WW	1	Door Bracket	P4412A
XX	2	Door Curved Handle	P0270A
YY	1	Door Stop	P80Q9A
ZZ	4	Caster Seat	P4525B
AAA	4	3" Industry Caster	P5115B
BBB	1	Regulator (4" WC)	P3640A
CCC	1	AA Battery	P8080A
DDD	1	Motor	P80M8A
EEE	1	Motor Bracket	P80Q2A
FFF	2	Fork	P80Q3A
GGG	1	Collar	P80Q4A
HHH	1	Bushing	P80Q5A
III	1	Handle	P8083E
JJJ	1	Spit	P80Q6A
KKK	3	Tool Hook	P80Q1A
LLL	1	Basket	P55K2A
MMM	1	Rotisserie Ignitor Wire	P80R4A
NNN	1	Brass Fitting (Manifold)	P39B6A
OOO	1	Brass Fitting (Regulator)	P39B7A
	1	Caster Wrench	P55L4A
	1	Hardware Pack	P4185A
	1	Owners Manual	P47F3A



## Assembly - 4632241

### • Unpack and remove all protective packaging.

1. Position bottom shelf with the top holes toward you. This is the front. See **Fig. 1**.

**VERY IMPORTANT:** The labels on the cart legs indicate their assembly position to the bottom shelf. **LF=Left Front**, **LR=Left Rear**, **RF=Right Front**, and **RR=Right Rear**. Labels should face inward toward each other when correctly assembled. **Remaining components cannot be assembled if leg positions are incorrect.**

2. Install the four cart legs to the indicated corners of the bottom shelf using 8 of the **1/4x2-1/2"** Phillips-head screws provided. Do not fully tighten screws.
3. Install bowl support brackets, facing inward, to cart legs on both sides using 8 of the **1/4x1/2"** Phillips-head screws. Fully tighten. See **Fig. 1**.

**FIGURE 1**

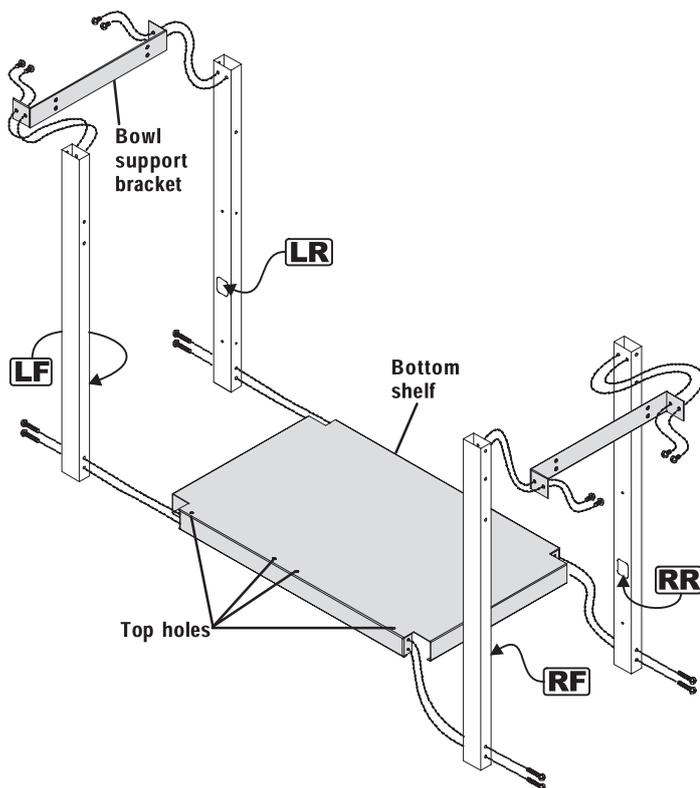

4. Screw the 4 casters into the caster seats in the bottom of each cart leg. Turn the threaded caster stem by hand, clockwise until it stops. Fully tighten with the wrench provided. See **Fig. 2**.
5. Install the two side panels and one rear panel to the cart by using 4 of the **3/16x1/2"** Phillips-head screws on each panel. Leave rear panel screws loose. See **Fig. 2**.

**FIGURE 2**

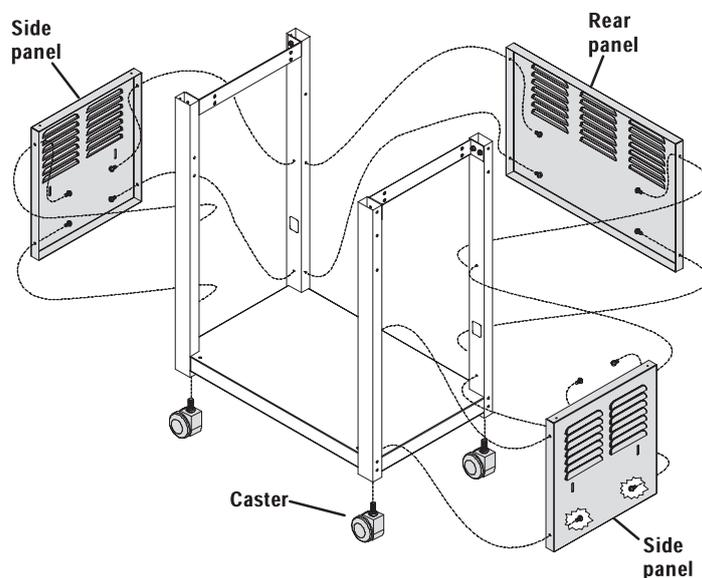

6. Attach the door bracket to the **lower holes** in the front legs with the end tabs pointing upward and the flange to the rear, pointing downward. Use 2 of the **1/4x1/2"** Phillips-head screws. Do not fully tighten. See **Fig. 3**.
7. Attach the door stop to the bottom shelf, with the flange facing the front, using 2 of the **3/16x3/8"** Phillips-head screws and **3/16"** lock nuts. Fully tighten. See **Fig. 3**.
8. Place doors into the hinge holes of the bottom shelf and door bracket. Push door bracket down until doors are secure and can open and close freely. Do not fully tighten door bracket screws. See **Fig. 3**.
9. Remove protective film from doors. Install door handles to doors using 4 of the **3/16x3/8"** Phillips-head screws and washers. See **Fig. 3**.
10. Attach the 4 side shelf brackets to the tops of the cart legs using 8 of the **1/4x1/2"** Phillips-head screws. Be sure the flat side of each bracket faces outward. Fully tighten. See **Fig. 3**.

**FIGURE 3 ON NEXT PAGE**

11. Place the side shelves over the shelf brackets and bowl support brackets with the wider-spaced shelf holes to the outside (shelf with trim plate on right side). Be sure the inside shelf holes align with holes in bowl support bracket. See **Fig. 3**.
12. To install the side shelf handle, remove the bolt and washer from one side of the handle (cap remains with handle). From beneath shelf, place washer onto bolt and insert bolt through end of shelf bracket, side shelf, and into handle. Leave bolt loose until other side of handle is attached, then fully tighten both sides. Repeat for other side shelf. See **Fig. 3**.

**FIGURE 3**

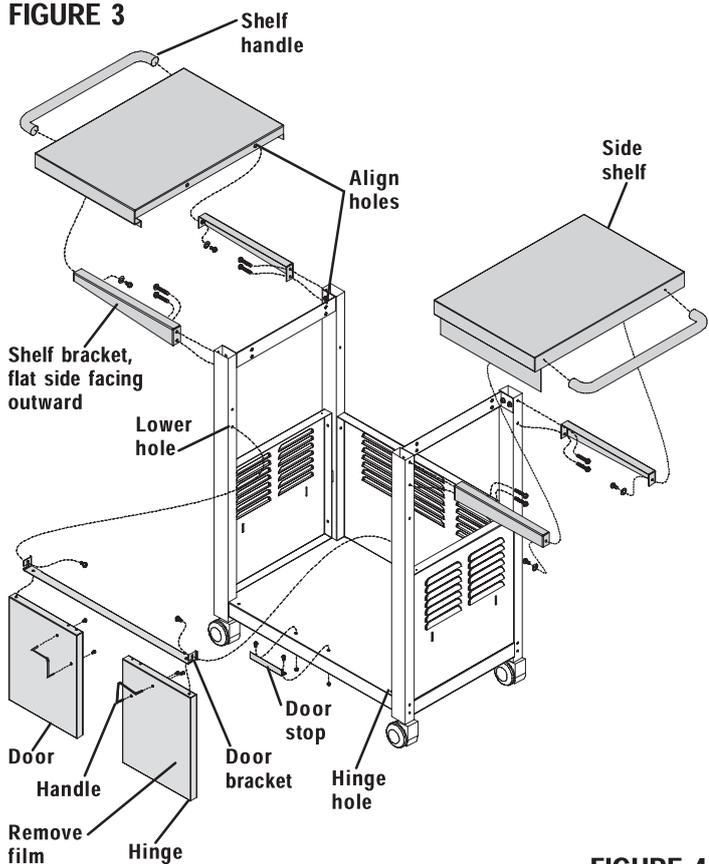

**FIGURE 4**

13. Install basket to right side panel by placing basket hooks into panel vents and securing bottom of basket to panel using 2 of the **3/16x3/8"** Phillips-head screws and **3/16"** lock nuts. Fully tighten. See **Fig. 4**.
14. Hang three tool hooks from right side shelf trim plate. See **Fig. 4**.

**Note:** Some previously assembled components not shown for clarity.

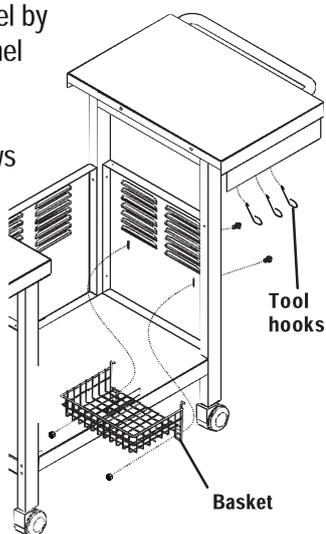

To reduce the weight of the grill head, open the grill lid and remove the packed components. **This step requires 2 people to lift and position the grill head onto the cart.**

15. **HINT:** Slide grill head into cart from the front. **Use care to avoid scratching tops of side shelves.** Align the 2 holes beneath the hang ledge on each side of the grill head with the 2 holes in the side shelf and bowl support bracket on the cart. Raise the grill lid and insert 4 of the **1/4x1/2"** Phillips-head screws. Beneath the side shelves, add **1/4"** nuts. Do not fully tighten. See **Fig. 5**.

**FIGURE 5**

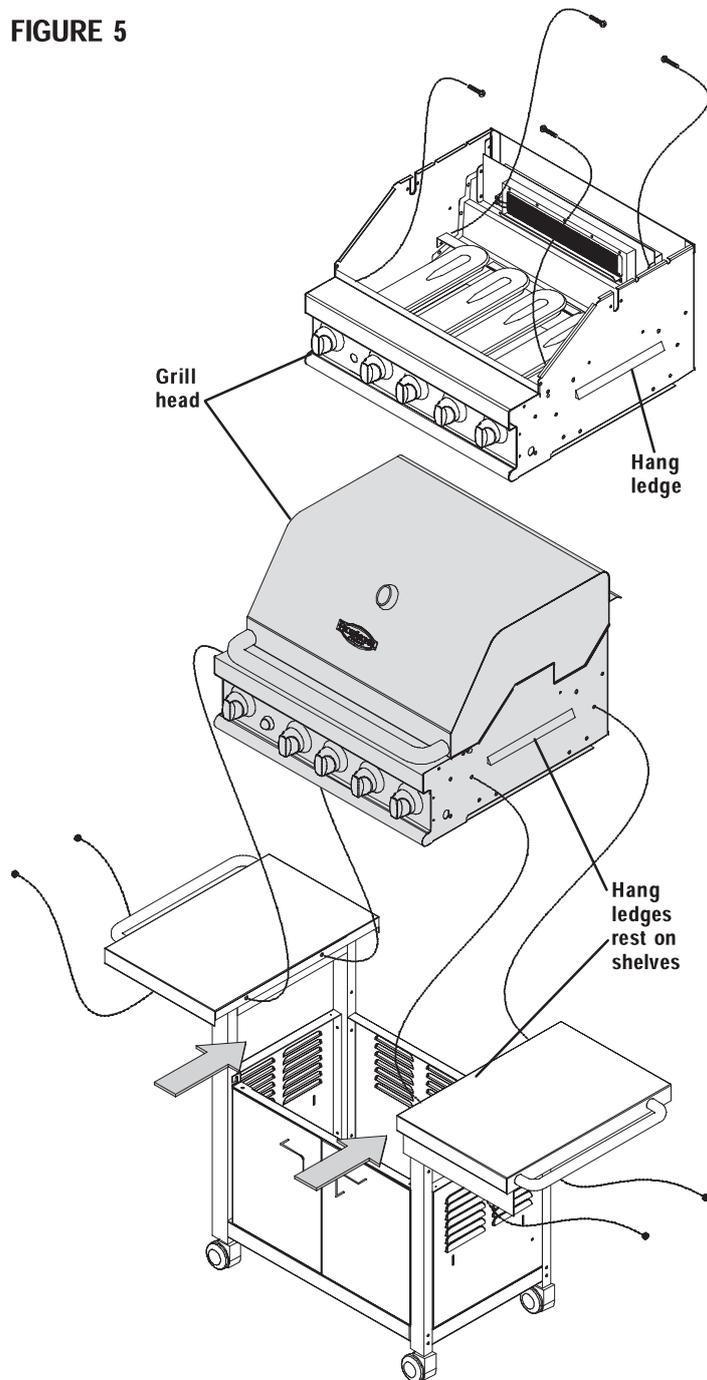



16. Secure grill head to all cart legs using 4 of the **1/4x2-1/2"** Phillips-head screws and **1/4"** nuts. See Fig. 6.

17. Fully tighten all leg screws, rear panel screws, door bracket screws, and grill head screws.

18. From the back of the cart, slide the grease draining tray into the grill head. Place the grease receptacle into the notches on the bottom of the tray. See Fig. 6.

FIGURE 6

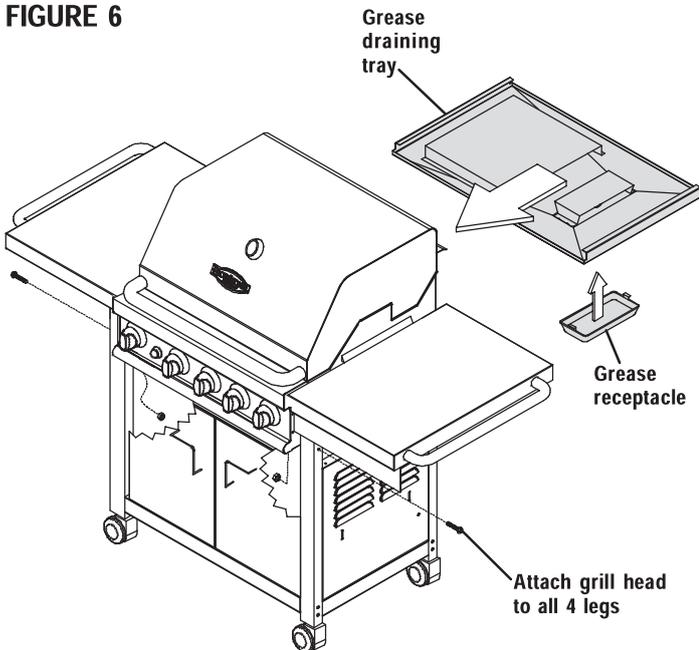

19. Unscrew the ignitor cap located on the control panel and remove the contact and spring from the ignitor slot. See Fig. 7.

20. Place the supplied AA battery into the ignitor slot with the positive pole facing toward you.

21. Place the spring with contact over the battery. Screw the ignitor cap back onto the control panel.

FIGURE 7

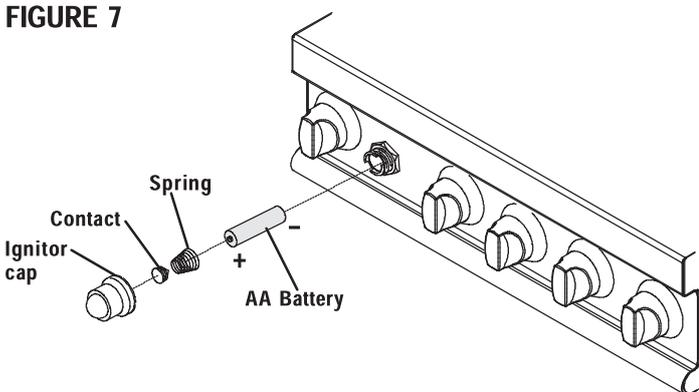

22. Thread the **L-shaped** fitting on regulator onto the manifold. Be sure the regulator is pointing **down**, then wrench-tighten the connection. See Fig. 8.

FIGURE 8

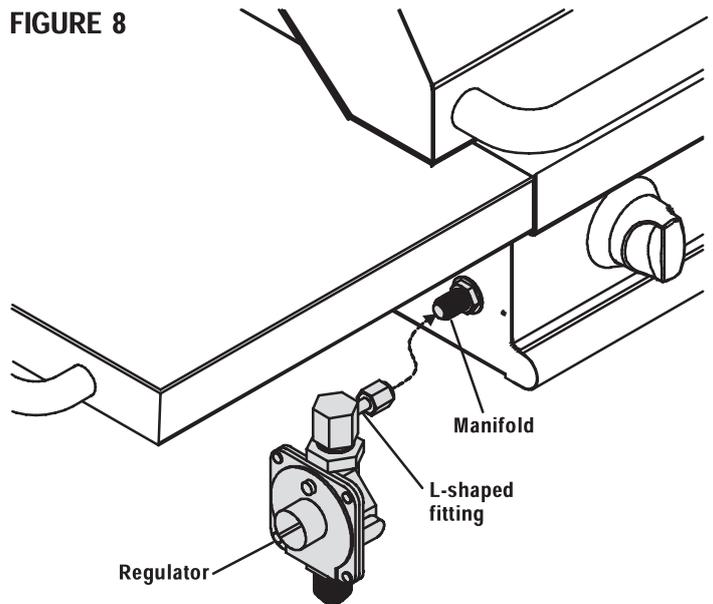

23. Attach trim plate to front of left shelf by placing top lip of plate **ABOVE** bottom lip of shelf. Secure using three **3/16"x3/8"** Phillips-head screws and **3/16"** nuts. Fully Tighten. See Fig. 9.

FIGURE 9

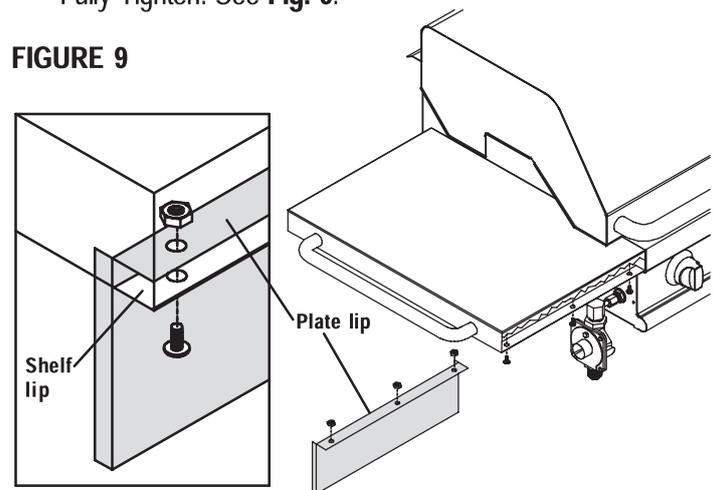

24. Place the 3 flame tamers on the lower ledge above burners. See **Fig. 10**. They should meet in the center.
25. Place the cooking grids on the ledge above the flame tamers. See **Fig. 10**.
26. Place the warming rack into the slots on the upper left and upper right of the grill bowl panels. See **Fig. 10**.

**FIGURE 10**

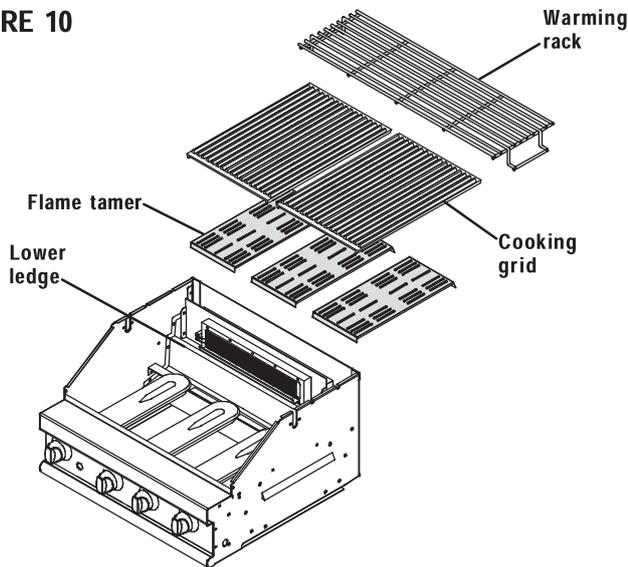

27. Attach rotisserie motor bracket to bowl side panel using screws, washers, and nuts provided, then slide motor onto bracket. See **Fig. 11**.
28. Twist handle onto threaded end of spit rod, then add bushing, collar, and forks to spit. Insert spit into motor and rest collar in groove of opposite side.

**FIGURE 11**

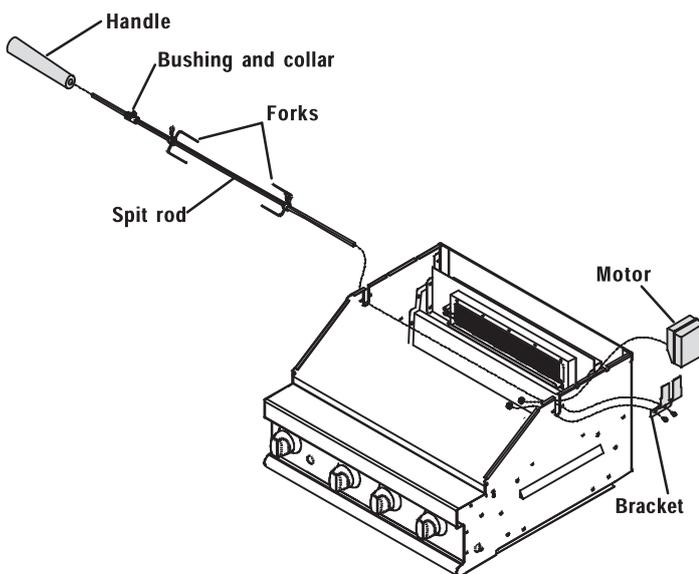

29. Thread the natural gas hose (*sold separately*) onto the regulator fitting and wrench-tighten the connection. See **Fig. 12**. Please read "**Connecting Your Grill to the Natural Gas Source**" and "**Leak Testing**"; in the **Use and Care** section, before using your grill.

**FIGURE 12**

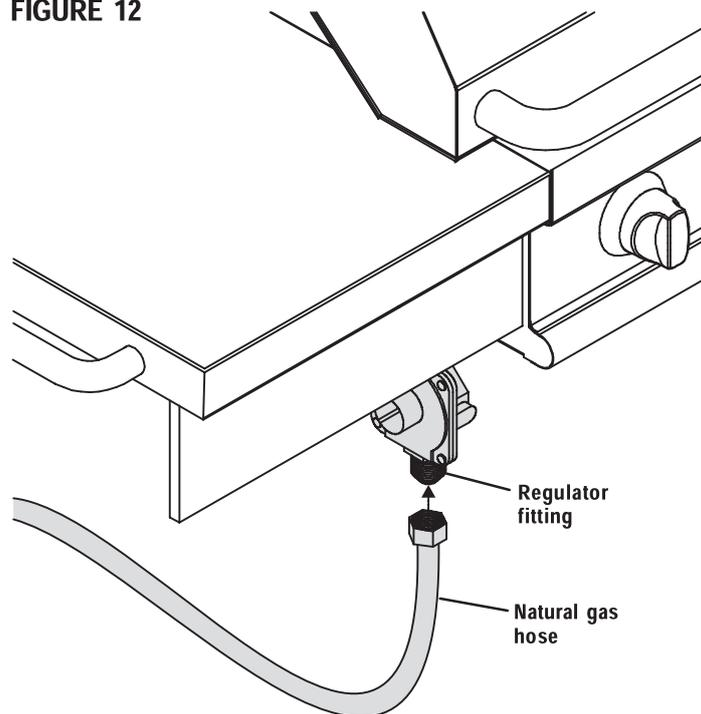

### Before Your First Cookout

- Perform the leak test as indicated in the use and care section.
- Wash the cooking grids, griddle, cooking rack, and all stainless steel surfaces with warm, soapy water. Rinse and dry thoroughly.
- Light burners. Check to make sure they are lit, then close the lid and warm the grill on HI for 15 minutes. Curing of paint and parts will produce an odor only on first lighting.

## Use and Care

### Connecting Your Grill to the Natural Gas Source

**IMPORTANT:** Regulator supplied with grill **MUST** be utilized for natural gas connection.

1. Coat pipe nipple with gas resistant dope. Screw socket onto gas manifold at gas source (A).
2. Connect unattached end of natural gas hose to socket. Push sleeve back on socket (B) and insert plug until sleeve snaps forward, locking plug into socket.

When socket and plug are connected, valve in socket opens automatically to permit full gas flow. When coupling is disconnected, valve in socket instantly and positively shuts off flow of gas. Because valve in socket positively shuts off flow of gas, grill can be disconnected from gas source by disconnecting hose from socket. Socket can be left on manifold of gas source if so desired.

With proper assembly, plug cannot be removed without pushing sleeve back. To disconnect, push sleeve back and pull plug out of sleeve (this automatically shuts off gas).

**Please Note:** Hose and assembly are A.G.A. certified and C.G.A. listed for natural gas, manufactured gas, mixed gas and for liquefied petroleum and for LP Gas-Air mixtures on basis of 0.64 specific gravity for 1000 BTU's per cubic foot of gas at 0.3 in. water column pressure drop. Only ANSI Z21.54 approved hoses should be used with this grill.

The appliance and its individual shut off valve must be disconnected from the gas supply piping system during any pressure testing of that system at test pressures in excess of 1/2 psig (3.5kPa).

The appliance must be isolated from the gas supply piping system by closing its individual manual shutoff valve during any pressure testing of the gas supply piping system at test pressures equal to or less than 1/2 psi (3.5 kPa).

### **⚠ WARNING**

- Connection to gas source must be done by a certified plumber.

### **⚠ WARNING**

- Do not use hard metal piping of any kind to connect this type of grill to natural gas source. Use **ONLY** hose specified by Char-Broil. Using hard metal piping or convoluted metal tubing is an unsafe practice. Movement of the grill can cause breakage of metal pipe.

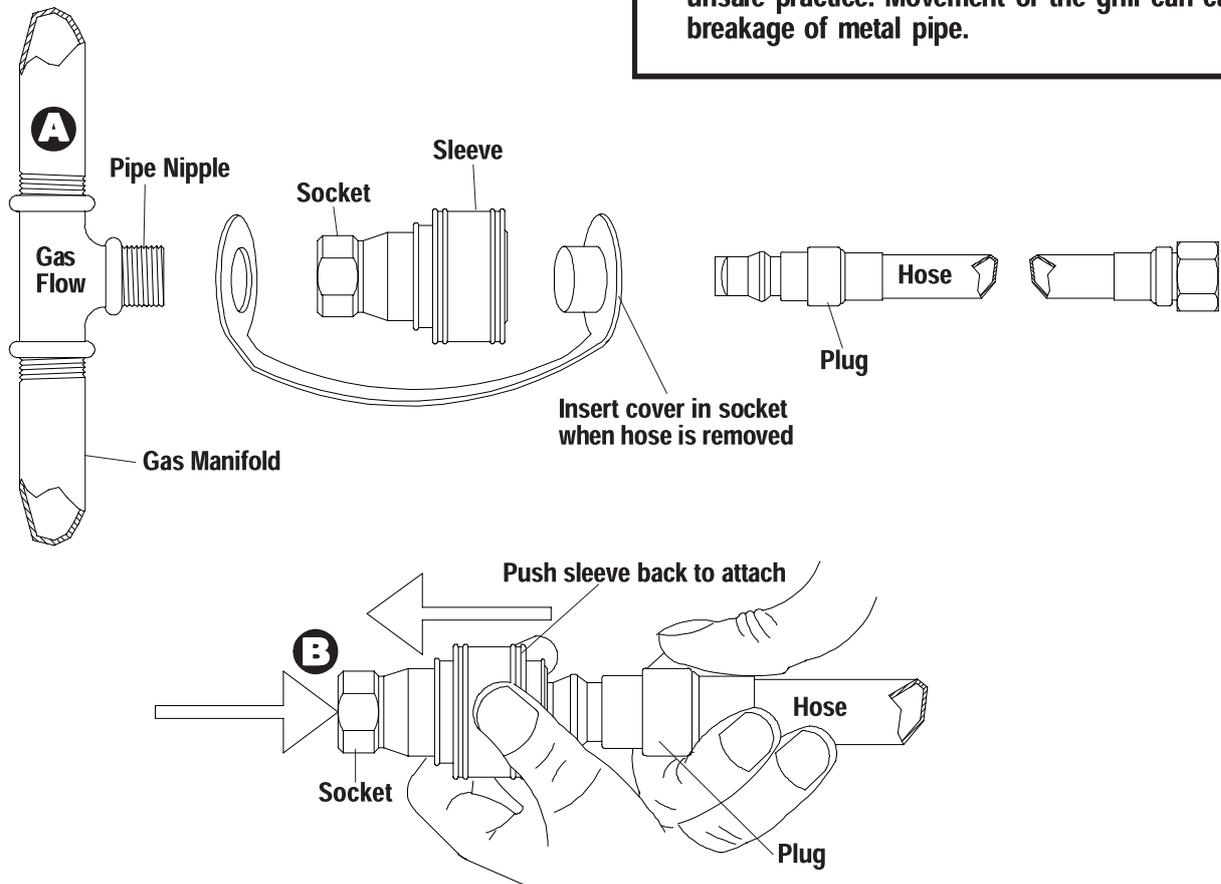

## ▲ WARNING

- Do not use grill until leak checked.
- If leak is detected at any time, STOP and call the Fire Department.
- If you cannot stop a gas leak, *immediately* turn gas off at gas source and call natural gas supplier or your fire department!

### Leak Testing

1. Turn all grill control knobs to OFF.
2. Check to make sure grill is connected to natural gas source and gas supply is turned on. If you hear a *rushing sound*, turn gas off immediately. There is a major leak at the connection. **Correct before proceeding.**
3. Brush soapy solution onto following connections:

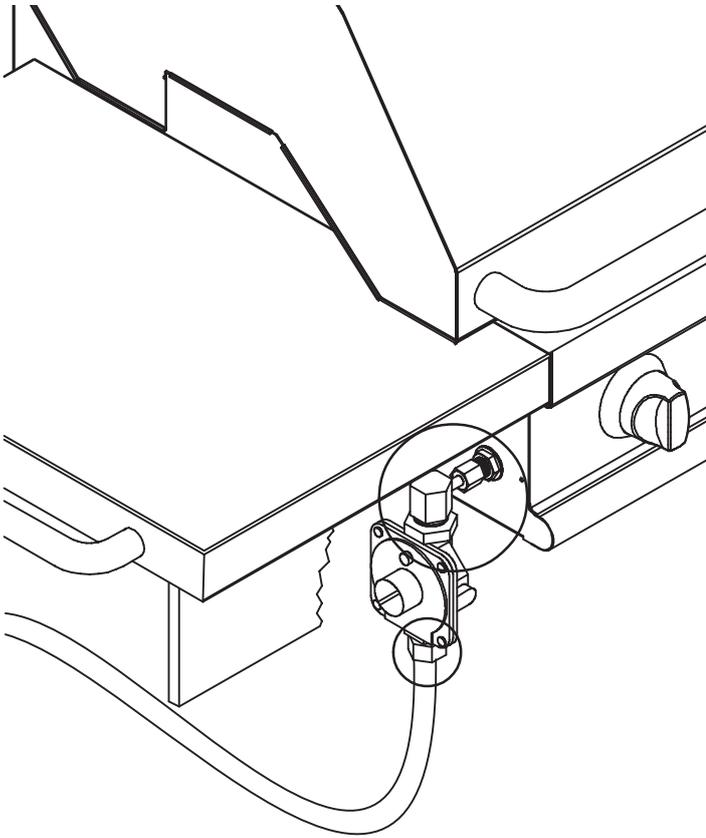

4. "If growing" bubbles appear, there is a leak. Turn gas off at gas source immediately and retighten connections. **If leaks cannot be stopped "do not try to repair."** Call for replacement parts. Order new parts by giving the serial, model number and name of items needed to the Grill Service Center at ☎1-800-241-7548.

### Safety Tips

- ▲ When grill is not in use, turn off all control knobs and gas source.
- ▲ Never move grill while in operation or still hot.
- ▲ When moving the grill push it forward, do not pull from behind.
- ▲ Use long-handled barbecue utensils to avoid burns and splatters.
- ▲ Do not remove grease receptacle or tray until grill has completely cooled.
- ▲ If you notice grease or other hot material dripping from grill onto valve or regulator turn off gas supply at once. Determine the cause, correct, clean and inspect valve and regulator before continuing. Perform a leak test.
- ▲ The regulator may make a humming or whistling noise during operation. This will not affect safety or use of grill.
- ▲ If you have a grill problem see the "Troubleshooting Section".

## ▲ WARNING

### For Safe Use Of Your Grill:

- Do not let children operate or play near grill.
- Keep grill area clear and free from materials that burn.
- Do not block holes in bottom or back of grill.
- Check burner flames regularly.
- Use grill only in well-ventilated space. NEVER use in enclosed space such as carport, garage, porch, covered patio, or under a surface that can catch fire.
- Use grill at least 3 ft. from any wall or surface. Maintain 10 ft. clearance to objects that can catch fire or sources of ignition such as pilot lights on water heaters, live electrical appliances, etc.
- Do not use charcoal, briquets or lava rock in this grill.
- **Apartment Dwellers:**  
Check with management to learn the requirements and fire codes for using an Gas Grill in an apartment. If allowed use outside on the ground floor with a three (3) foot clearance from walls or rails. Do not use on or under balconies made of wood.
- **NEVER attempt to light burner with lid closed. A buildup of non-ignited gas inside a closed grill is hazardous.**

## ▲ CAUTION

- Putting out grease fires by closing the lid is not possible. Grills are well ventilated for safety reasons.
- Do not use water on a grease fire. Personal injury may result. If a grease fire develops turn knobs and gas source off.
- Do not leave grill unattended while preheating or burning off on high. If grill has not been regularly cleaned a grease fire can occur that may damage the product.

### Ignitor Lighting

#### ▲ Do not lean over grill while lighting.

1. Open lid during lighting
2. To ignite any burner, turn knob to HI, push and hold ELECTRONIC IGNITOR button for 5 seconds.
3. If ignition does not take place within 5 seconds, turn all burner knobs to OFF, wait 5 minutes, then repeat lighting procedure.
4. If IGNITOR does not work, follow match lighting instructions.

#### Match Lighting

##### ▲ Do not lean over grill while lighting.

1. Open lid during lighting.
2. Place lit match into match lighting stick, then into lighting hole on right side of grill.
3. Push in and turn far right burner knob to HI. Be sure burner lights and stays lit.
4. Light adjacent burners in sequence by pushing knobs in and turning to HI.

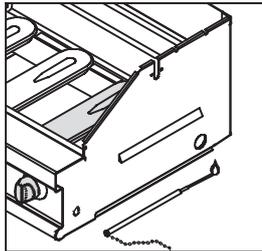

### Rotisserie Ignitor Lighting

#### ▲ Do not lean over grill while lighting.

1. Open lid during lighting
2. To ignite rotisserie burner, push in and turn rotisserie knob **slowly**, to ON, allowing gas to reach burner. Built-in ignitor should click and light burner. If burner does not light, repeat lighting procedure up to 5 times.
3. If IGNITOR does not work, follow match lighting instructions.

#### Match Lighting

##### ▲ Do not lean over grill while lighting.

1. Open lid during lighting.
2. Place lit match near rotisserie spark electrode wire.
3. Push in and turn rotisserie knob to ON. Be sure burner lights and stays lit.

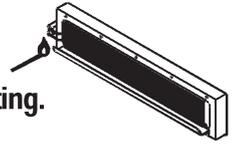

### Burner Flame Check

- Remove grates and flametamers. Light burners, rotate knobs from HI to LOW. You should see a smaller flame in LOW position than seen on HI. Always check flame prior to each use. If only low flame is seen refer to "Sudden drop or low flame" in the *Troubleshooting Section*.

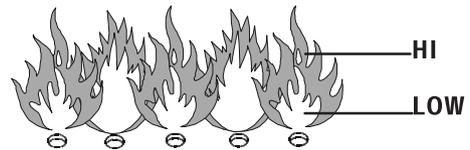

### Turning Grill Off

- Turn all knobs to OFF position. Turn gas OFF at gas source.

### Ignitor Check

- **Turn gas off at gas source.** Push and hold electronic ignitor button. "Clicks" should be heard and spark seen each time between collector box or burner and electrode. See "*Troubleshooting*" if no click or spark.

### Valve Check

- **Important: Make sure gas is OFF at gas source before checking valves.** Knobs lock in OFF position. To check valves, first push in knobs and release, knobs should spring back. If knobs don't spring back, replace valve assembly before using grill. Turn knobs to **LOW** position then turn back to **OFF** position. Valves should turn smoothly.

### Hose Check

- Before each use, check to see if hoses are cut or worn. Replace damaged hoses before using grill. Use only valve/hose/regulator specified by manufacturer.

## ▲ WARNING

- If burner does not light turn knobs to OFF, wait 5 minutes, try again.

## Cleaning The Burner Assembly

Follow these instructions to clean and/or replace parts of burner assembly or if you have trouble igniting grill.

1. **Turn gas off at control knobs and gas source.**
2. Remove cooking grates, flametamers, grease tray and grease receptacle.
3. Remove cotter pins from beneath each burner "foot" using a screwdriver or needle nose pliers.
4. Carefully lift each burner up and away from valve openings.

We suggest three ways to clean the burner tubes. Use the one easiest for you.

- (A) Bend a stiff wire (a light weight coat hanger works well) into a small hook. Run the hook through each burner tube and burner several times.



- (B) Use a narrow bottle brush with a flexible handle (do not use a brass wire brush), run the brush through each burner tube and burner several times.

- (C) **Wear eye protection:** Use an air hose to force air into the burner tube and out the burner ports. Check each port to make sure air comes out each hole.

5. Wire brush entire outer surface of burner to remove food residue and dirt.
6. Clean any blocked ports with a stiff wire such as an open paper clip.
7. Check burner for damage, due to normal wear and corrosion some holes may become enlarged. If any large cracks or holes are found replace burner.

### **VERY IMPORTANT: Burner tubes must reengage valve openings.**

8. Carefully replace burners.
9. Replace cotter pin beneath each burner.
10. Replace grease tray and receptacle, flametamers, and cooking grates.

## General Grill Cleaning

- Do not mistake brown or black accumulation of grease and smoke for paint. Interiors of gas grills are not painted at the factory (**and should never be painted**). Apply a strong solution of detergent and water or use a grill cleaner with scrub brush to insides of grill lid and bottom. Rinse and allow to completely air dry. **Do not apply a caustic grill/oven cleaner to painted surfaces.**
- **Plastic parts:** wash with warm soapy water and wipe dry.
  - ▲ Do not use citrisol, abrasive cleaners, degreasers or a concentrated grill cleaner on plastic parts. Damage to and failure of parts can result.

## ▲ CAUTION



Clean burners prior to use after storing, at the beginning of grilling season or a period of one month not being used. Spiders and insects like to build nests in burner tubes (especially during colder months). These nests can cause fires in burner tubes or under grill.

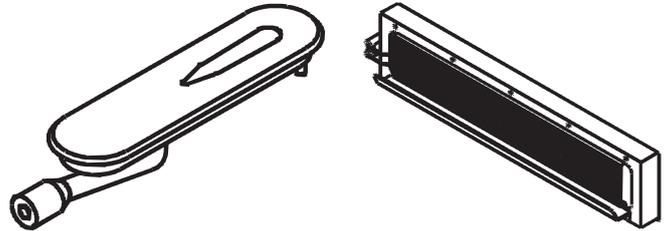

- **Porcelain surfaces:** because of glass-like composition, most residue can be wiped away with baking soda/water solution or specially formulated cleaner. Use nonabrasive scouring powder for stubborn stains.
- **Painted surfaces:** Wash with mild detergent or nonabrasive cleaner and warm soapy water, wipe dry with a soft nonabrasive cloth.
- **Stainless steel surfaces:** To maintain your grill's high-quality appearance, wash with mild detergent and warm soapy water, wipe dry with a soft cloth after each use. Baked-on grease deposits may require the use of an abrasive plastic cleaning pad.

## Storing Your Grill

- Clean cooking grates
- Store in dry location.
- Cover grill if stored outdoors. Choose from a variety of grill covers offered by Char-Broil.
- Store grill indoors **ONLY** if gas source is disconnected.
- When removing grill from storage follow "*Cleaning the Burner Assembly*" instructions before starting grill.

## Indirect Cooking

Poultry and large cuts of meat cook slowly to perfection on the grill by indirect heat. The heat from selected burners circulates gently throughout the grill, cooking meat or poultry without the touch of a direct flame. This method greatly reduces flare-ups when cooking extra fatty cuts because there is no direct flame to ignite the fats and juices that drip during cooking.

### Indirect Cooking Instructions

- Always cook with the lid closed.
- Due to weather conditions, cooking times may vary. During cold and windy conditions the temperature setting may need to be increased to insure sufficient cooking temperatures.

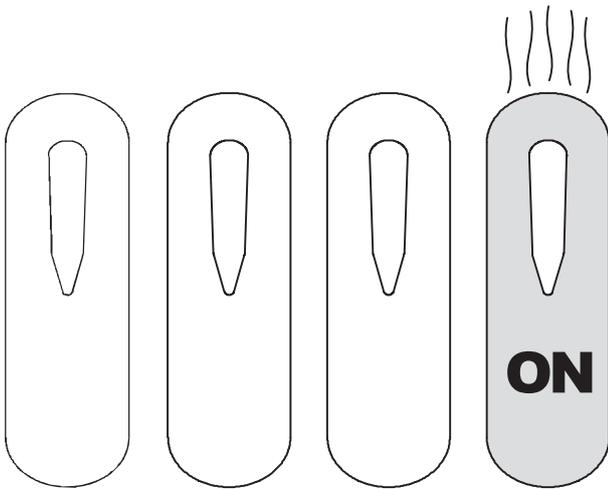

### 1 Burner Cooking

Cook with direct or indirect heat.  
Best for smaller meals or foods.  
Consumes less fuel.

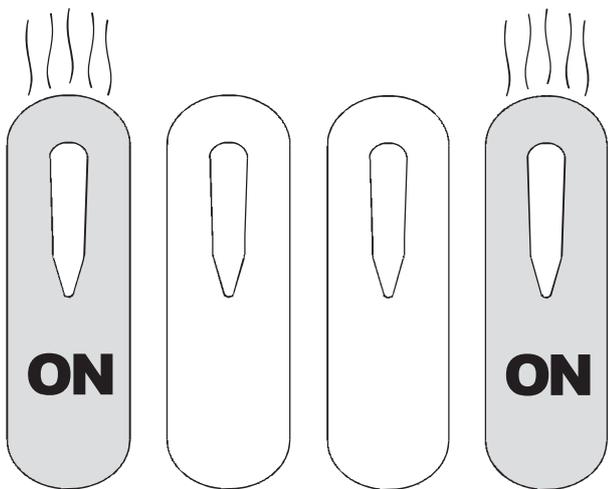

### 2 Burner Cooking

Great indirect cooking on low.  
Produces slow, even heating.  
Ideal for slow roasting and baking.

## Food Safety

- Food safety is a very important part of enjoying the outdoor cooking experience. To keep food safe from harmful bacteria, follow these four basic steps:

**Clean:** Wash hands, utensils, and surfaces with hot soapy water before and after handling raw meat and poultry.

**Separate:** Separate raw meats and poultry from ready-to-eat foods to avoid cross contamination. Use a clean platter and utensils when removing cooked foods.

**Cook:** Cook meat and poultry thoroughly to kill bacteria. Use a thermometer to ensure proper internal food temperatures.

**Chill:** Refrigerate prepared foods and leftovers promptly.

### How To Tell If Meat Is Grilled Thoroughly

- Meat and poultry cooked on a grill often browns very fast on the outside. Use a meat thermometer to be sure food has reached a safe internal temperature, and cut into food to check for visual signs of doneness.
- Whole poultry should reach 180° F; breasts, 170° F. Juices should run clear and flesh should not be pink.
- Hamburgers made of any ground meat or poultry should reach 160° F, and be brown in the middle with no pink juices. Beef, veal and lamb steaks, roasts and chops can be cooked to 145° F. All cuts of pork should reach 160° F.
- NEVER partially grill meat or poultry and finish cooking later. Cook food completely to destroy harmful bacteria.
- When reheating takeout foods or fully cooked meats like hot dogs, grill to 165° F, or until steaming hot.

## Troubleshooting

Problem	Possible Cause	Prevention/Cure
<b>Burner will not light using ignitor.</b>	<p>Wires and/or electrode covered with cooking residue.</p> <p>Electrode cracked or broken "sparks at crack"</p> <p>Electrode tip not in proper position</p> <p>Wires are loose or disconnected.</p> <p>Wire is shorting (sparking) between ignitor and electrode.</p> <p>Dead battery.</p>	<p>Clean wires and/or electrode with rubbing alcohol and clean swab.</p> <p>Replace electrode(s).</p> <p>Main Burners: Tip of electrode should be pointing toward tip of collector box. The distance should be 1/8" to 1/4", adjust if necessary.</p> <p>Sideburner: Tip of electrode should be pointing toward gas port opening on burner. The distance should be 1/8" to 3/16", adjust if necessary.</p> <p>Reconnect wires or replace electrode/wire assembly.</p> <p>Replace ignitor wire/electrode assembly.</p> <p>Replace with a new AA battery.</p>
<b>Burners will not match light.</b>	<p>No gas flow.</p> <p>Obstruction of gas flow.</p> <p>Disengagement of burner to valve.</p>	<p>Turn gas on at source.</p> <p>Clear burner tubes.</p> <p>Reengage burner and valve.</p>
<b>Flames blow out.</b>	<p>High or gusting winds.</p>	<p>Turn front of grill to face wind or increase flame height.</p>
<b>Flare-up.</b>	<p>Grease buildup.</p> <p>Excessive fat in meat.</p> <p>Excessive cooking temperature.</p>	<p>Clean grill.</p> <p>Trim fat from meat before grilling.</p> <p>Adjust (lower) temperature accordingly or use indirect cooking.</p>
<b>Persistent grease fire.</b>	<p>Grease trapped by food buildup around burner system.</p>	<p>Turn knobs to OFF. Turn gas off at gas source. Leave lid in position and let fire burn out. <i>After grill cools, remove and clean all parts.</i></p>
<b>Flashback...</b> (fire in burner tubes)	<p>Burner and/or burner tubes are blocked.</p>	<p>Clean burner and/or burner tubes.</p>





**A Division of W.C. Bradley Co.**

P. O. Box 1240

Columbus, GA 31902-1240