

This Owner's Manual is provided and hosted by [Appliance Factory Parts](#).



Charbroil 466231203 Owner's Manual

[Shop genuine replacement parts for Charbroil
466231203](#)



[Find Your Charbroil Grill Parts - Select From 3592 Models](#)

----- Manual continues below -----

ASSEMBLY, USE AND CARE MANUAL

466231203

THIS GRILL IS FOR
OUTDOOR USE ONLY



CAUTION:

Read and follow all safety statements, assembly instructions, and use and care directions before attempting to assemble and cook.

**INSTALLER/
ASSEMBLER:**

Leave these instructions with consumer.

CONSUMER:

Keep this manual for future reference.

⚠ WARNING

Failure to follow all manufacturer's instructions could result in serious personal injury and/or property damage.

⚠ CAUTION

Some parts may contain sharp edges - especially as noted in the manual! Wear protective gloves if necessary.

If you have any questions
or need assistance
during assembly,
please call
1-800-241-7548 U.S.
1-800-387-6057 CAN

Char-Broil
KEEPERS OF THE FLAME

Visit us on the web at:
www.charbroil.com

466231203 / P80112002A (04-15-03)

COMMERCIAL SERIES

WARNING

FOR YOUR SAFETY

1. Do not store or use gasoline or other flammable vapors and liquids in the vicinity of this or any other appliance.
2. An LP Tank not connected for use shall not be stored in the vicinity of this or any other appliance.

FOR YOUR SAFETY

If you smell gas:

1. Shut off gas to the appliance.
2. Extinguish any open flame.
3. Open lid.
4. If odor continues, immediately call your gas supplier or your fire department.

Call Grill Service Center For Help And Parts

- If you need help or warranty parts call ☎ 1-800-241-7548 U.S. or 1-800-387-6057 CAN, or send a FAX to 1-706-576-6355. Business hours: Open 24 hours - Seven days a week.
- To order non-warranty replacement parts or accessories (*grill cover, cleaners, paint*) call 1-800-993-2677 or send a FAX to 1-706-565-2121.

Important: Fill out Warranty Information below

Warranty Information

Model Number _____

Lot Number (on carton label) _____

Serial Number _____

Date Purchased _____

CAUTION

- For residential use only. Do not use for commercial cooking.

Installation Safety Precautions

- Use grill only with LP (propane) gas and the regulator/valve assembly supplied.
- Grill installation must conform with local codes, or in their absence with **National Fuel Gas Code, NFPA 54 / ANSI Z223.1** or **CAN/CGA-B149.2 Propane Installation Code**. Handling and storage of LP cylinders must conform to LP Gas Code **NFPA/ANSI 58**. Grill is not for use in or on recreational vehicles and/or boats.
- All electrical accessories (such as rotisserie) must be electrically grounded in accordance with local codes, or **National Electrical Code, ANSI / NFPA 70** or **Canadian Electrical Code, CSA C22.1**. Keep any electrical cords and/or fuel supply hoses away from any hot surfaces.
- This grill is safety certified for use in the United States and Canada only. Do not modify for use in any other location. Modification will result in a safety hazard.

Safety Symbols

- The symbols and boxes shown below explain what each heading means. Read and follow all of the messages found throughout the manual.

DANGER

- **DANGER:** Indicates an imminently hazardous situation which, if not avoided, will result in death or serious injury.

WARNING

- **WARNING:** Be alert to the possibility of serious bodily injury if the instructions are not followed. Be sure to read and carefully follow all of the messages.

CAUTION

- **CAUTION:** Indicates a potentially hazardous situation which, if not avoided, may result in minor or moderate injury.

Table of Contents

For Your Safety	2
Call Grill Service Center For Help And Parts	2
Installation Safety Precautions	2
Safety Symbols	2
Table of Contents	3
Warranty	3
Before Beginning Assembly	4
Parts List	4
Exploded View	5
Assembly	6-9
Use and Care	9-14
Storing Your Grill	13
Indirect Cooking	14
Food Safety	14
Troubleshooting	15

Warranty

Char-Broil warrants to the original consumer-purchaser that this product shall be free from defects in workmanship and materials under normal and reasonable use and correct assembly (if assembled by consumer-purchaser), from date of purchase.

Stainless steel and die cast parts - 99 years
Electronic ignition and burners - 10 years
Remaining parts - 2 years

Char-Broil will, at its option, refinish or replace any product or part found to be defective during the warranty period. Char-Broil will require you to return the part(s) claimed to be defective, for its inspection, freight or postage prepaid.

If you wish to obtain performance of any obligation under this limited warranty, you should write to:

CHAR-BROIL
Consumer Warranty / P.O. Box 1240
Columbus, GA 31902-1240

Char-Broil may require reasonable proof of purchase and we suggest you keep your receipt. In the state of California only, if refinishing or replacement of the product is not commercially practicable, the retailer selling this product or Char-Broil will refund the purchase price paid for the product, less the amount directly attributable to use by the original consumer-purchaser prior to discovery of the nonconformity. In addition, in the state of California only, you may take the product to the retail establishment from which it was purchased or to any retail establishment selling this product in order to obtain performance under this warranty.

This warranty does not include the cost on any inconvenience or property damage due to failure of the product and does not cover damage due to misuse, abuse, accident, damage arising out of transportation of the product, or damage incurred through commercial use of the product. This express warranty is the sole warranty given by the manufacturer and is in lieu of all other warranties, express or implied, including implied warranty of merchantability or fitness for a particular purpose. Neither Char-Broil dealers nor the retail establishment selling this product has any authority to make any warranties or to promise remedies in addition to or inconsistent with those stated above. Char-Broil's maximum liability, in any event, shall not exceed the purchase price of the product paid by the original consumer-purchaser. Some states do not allow the exclusion or limitation of incidental or consequential damages. So the above limitations or exclusions may not apply to you. This warranty gives you specific legal rights and may also have other rights which vary from state to state.

Before Beginning Assembly

- Necessary tools for assembly of your grill include: Phillips® screwdriver, pliers and adjustable wrench.

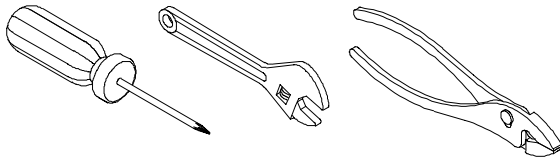

Certified Grill Parts And Accessories®, Char-Broil and Design®, Char-Broil (Gas Grill Briquettes)®, Char-Diamonds®, Cooking Zone and Design®, Diamond Flame®, Executive Chef®, Faststart®, Flare Fighter®, FlavorMaster®, Gas Grill Silhouette and Design®, H2O Smoker®, Lava Flame®, MasterFlame®, MasterFlame Precision Cooking System®, PowerSpark®, Quantum®, VIP®, PrecisionFlame and Design®, Sierra®, and TruFlame® are registered Trademarks of the W.C. Bradley Company. Thermos® is a registered trademark of the Thermos Company and its affiliates.

Artisan Collection by Char-Broil™, C3 and Design™, Char-Broil and Design™, Flame Design™, FlavorTents™, Grill 2 Go™, Grillin' Stick™, Keeper of the Flame™, Keepers of the Flame™, Natural Grip™, Outdoor Cooking Collection and Design™, Patio Bistro™, PrecisionFlame™, Pro-Check™, QuickSet Grills and Design™, SmokerTents™, The Big Easy™, The Minute Grill™, The Edge™, The Tuscan Collection™, and The Urban Grill™ are Trademarks of the W.C. Bradley Company. Universal Grill Parts and Design™ is a trademark of the Thermos Company and its affiliates.

Protected under one or more of the following U.S. Patents: 4,598,692; 4,624,240; 4,747,391; 4,747,391; 4,817,583; 4,924,846; 4,989,579; 5,003,960; 5,076,256; 5,076,257; 5,090,398; 5,109,834; 5,224,676; 5,277,106; 5,421,319; 5,441,226; 5,452,707; 5,458,309; 5,566,606; 5,566,606; 5,579,755; 5,582,094; 5,613,486; 5,649,475; 5,706,797; 5,711,663; 5,765,543; 5,931,149; 5,996,573; 6,095,132; 6,135,104; 6,279,566; D282,619; D339,714; D341,292; D343,337; D358,059; D361,466; D364,535; D372,637; D373,701; D377,735; D383,035; D397,910; D405,643; D405,643; D406,005; D406,009; D413,043; D413,229; D413,229; D414,982; D415,388; D416,164; D416,441; D416,441; D417,587; D422,516; D423,274; D423,876; D428,303; D435,396; D436,004; D438,059; D438,060; D438,427; D439,110; D442,505; D443,179; D443,354; D447,384; D447,385; D447,909; D448,610; D448,614; D448,615; D448,616; D448,975; and D449,492. Other Patents Pending.

Parts List - 466231203

Key	Qty	Description	Part #
A	1	Lid Plate	P00118036A
B	1	Lid Side Panel, Left	P00105037K
C	1	Lid Side Panel, Right	P00106037K
D	1	Heat Indicator	P00601181A
E	1	Plastic Lid Handle	P00202012A
F	1	Logo Plate	P00403003H
G	1	Warming Rack	P01505007E
H	2	Cooking Grid	P01615003E
I	3	Flame Tamer	P01705005E
J	1	Griddle	P05702002E
K	3	Burner	P02001031E
L	1	Burner Support Bracket	P02203052B
M	3	Gas Collector Box with Electrode	P02609002B
N	1	Electric Wire set	P02615062A
O	1	Electric Ignitor (4 port)	P02502024C
P	1	Bowl Side Panel, Left	P00720011A
Q	1	Bowl Side Panel, Right	P00721011A
R	1	Bowl Front Panel	P00724014A
S	1	Bowl Rear Panel	P00725014A
T	1	Rear Wind Shield	P00728051A
U	1	Grease Draining Tray	P02705084B
V	1	Grease Receptacle	P02701015B
W	1	Gas Manifold	P05003062A
X	3	Gas Valve for Main Burner	P03222024B
Y	1	Heat Shield for Control Panel	P03007032B
Z	1	Control Panel	P02P07501A
AA	3	Control Knob	P03411111G
BB	3	Control Knob Seat	P03415041J
CC	4	Spring	P05504017E
DD	1	Sideburner Frame (Left)	P01102013D
EE	1	Side Shelf, Right	P01103012D
FF	1	Bracket for Side Shelf - Left Front	P01204004C
GG	2	Bracket for Side Shelf - Left Rear, Right Front	P01206003C
HH	1	Bracket for Side Shelf - Right Rear	P01207002C
II	2	Front Panel, Side Shelf, Left	P07503001B
JJ	1	Cart Bottom Shelf	P01003006D
KK	2	Cart Side Panel	P07604002B
LL	1	Cart Rear Panel	P07702002B
MM	1	Door Bracket	P03301001D
NN	2	Door Front Plate	P04301002A
OO	2	Door Handle	P00214006A
PP	2	Bowl Support Bracket	P01306002D
QQ	1	Left Side Cart Leg, Front	P00910005C
RR	1	Left Side Cart Leg, Rear	P00911005C
SS	1	Right Side Cart Leg, Front	P00912005C
TT	1	Right Side Cart Leg, Rear	P00913005C
UU	4	Caster Seat	P04507003A
VV	4	3" Caster	P05106003D
WW	1	Pull-Out Tank Tray	P04009005C
XX	2	Bracket for Pull-Out Tank Tray	P04010006C
YY	1	Handle for Pull-Out Tank Tray	P00210004D
ZZ	2	Slide Set	P05516003C
AAA	1	Sideburner Lid	P0011508AA
BBB	1	Lid Knob for Sideburner	P00201008A
CCC	1	Pot Support	P00814002D
DDD	1	Electrode	P02614007C
EEE	1	Sideburner	P02002003D
FFF	1	Gas Valve for Sideburner	P03218102G
GGG	1	Control Knob	P03401031F
HHH	1	Connection Tube	P03702002A
III	1	Regulator with Hose (27")	P03601004A
JJJ	1	AA Battery	P05301001A
KKK	1	Front Panel, Side Shelf, Right	P07502001B
LLL	1	Sideburner Control Knob Seat	P03408051J
MMM	1	Match Lighting Stick with Chain	P05507031E
	1	Caster Wrench	P05515002C
	1	Grate Lifter	P05515014F
	1	Hardware Pack	P06004004A
	1	Owner's Manual	P80112002A

Exploded View - 466231203

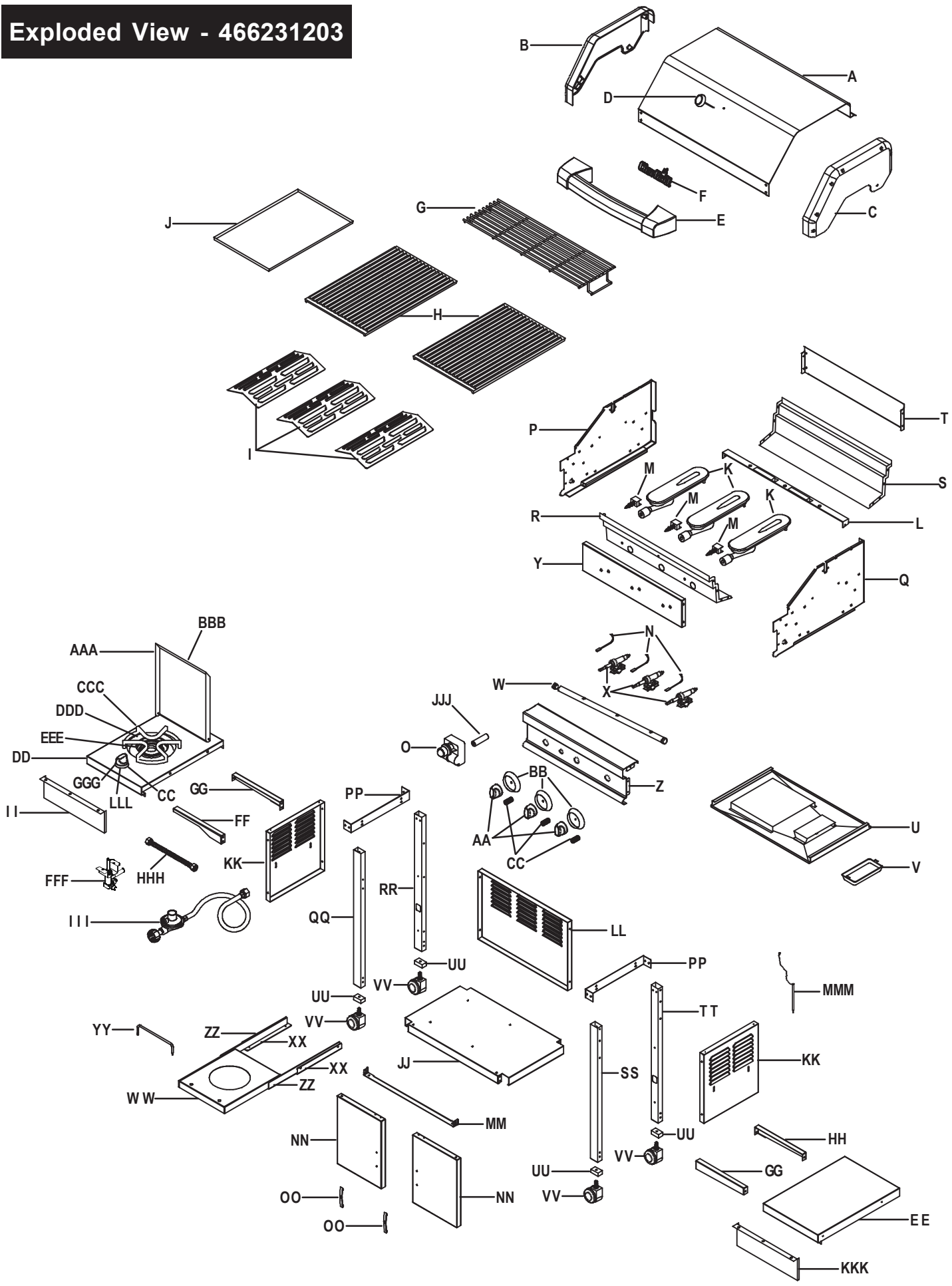

Assembly - 466231203

• Unpack and remove all protective packaging.

1. Position bottom shelf with the 4-hole pattern to the left side. See Fig. 1.

VERY IMPORTANT: The labels on the cart legs indicate their assembly position to the bottom shelf. **LF**=Left Front, **LR**=Left Rear, **RF**=Right Front, and **RR**=Right Rear. Labels should face inward toward each other when correctly assembled. **Remaining components cannot be assembled if leg positions are incorrect.**

2. Install the four cart legs to the indicated corners of the bottom shelf using 8 of the $1/4 \times 2-1/2$ " Phillips-head screws provided. Do not fully tighten screws.
3. Install cross braces, facing inward, to cart legs on both sides using 8 of the $1/4 \times 1/2$ " Phillips-head screws. Fully tighten. See Fig. 1.

FIGURE 1

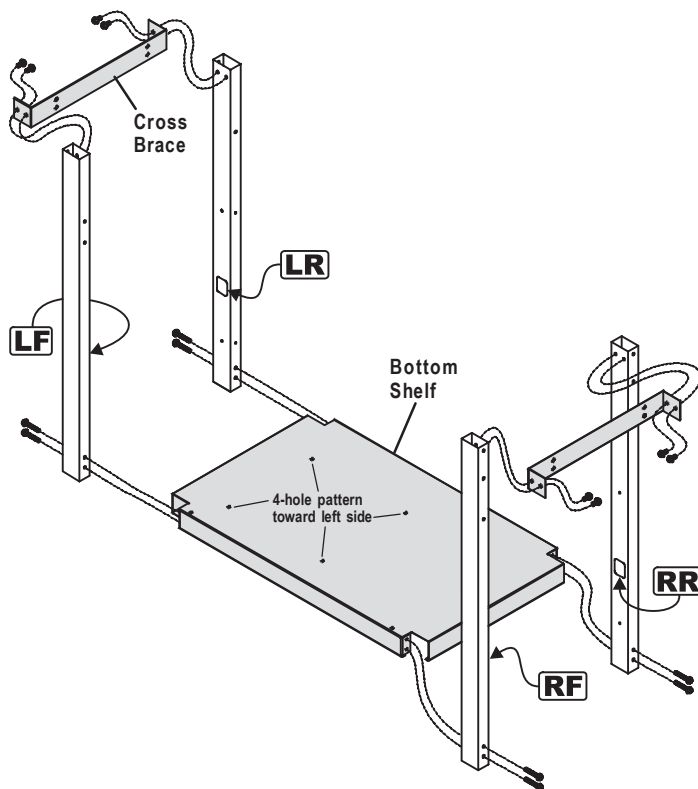

4. Screw the 4 casters into the caster seats in the bottom of each cart leg. Turn the threaded caster stem by hand, clockwise until it stops. Fully tighten with the wrench provided. See Fig. 2.
5. Install the two side panels and one rear panel to the cart by using 4 of the $3/16 \times 3/8$ " Phillips-head screws on each panel. Leave rear panel screws loose. See Fig. 2.

FIGURE 2

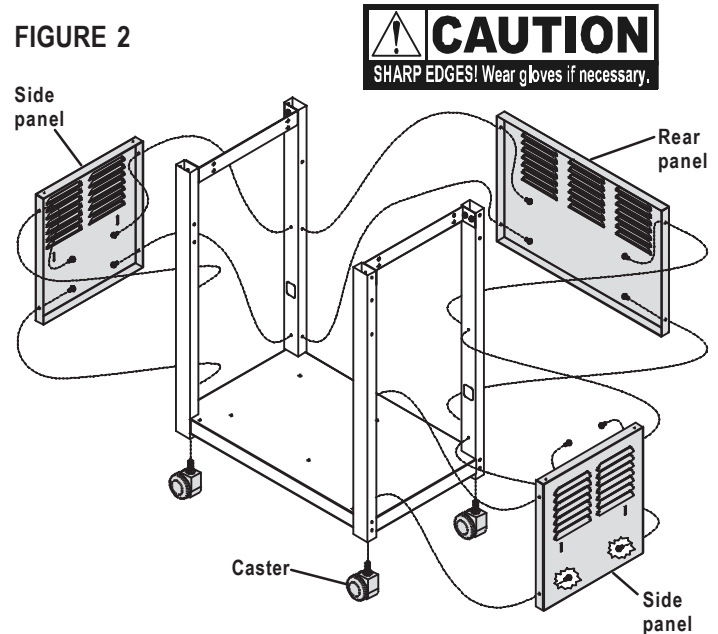

6. **USE CAUTION** when handling the pull-out tank tray. Slide rails have sharp edges. Install the handle on the pull-out tank using 2 of the $1/4$ " nuts. Fully tighten. See Fig. 3.
7. Fully extend the pull-out tank tray and attach the slide rails to the 4-hole pattern in the bottom shelf using 4 of the $1/4 \times 1/2$ " Phillips-head screws. Fully tighten. See Fig. 3.

FIGURE 3

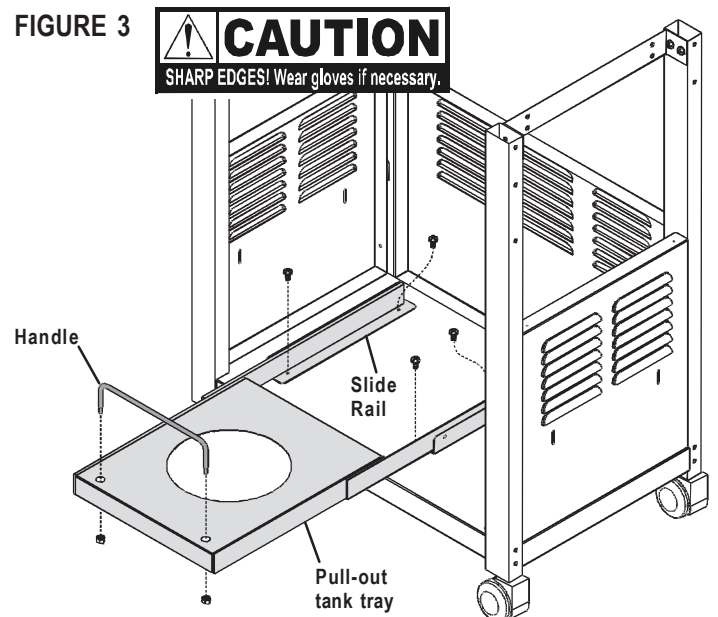

8. Attach the door bracket to the **lower holes** in the front legs with the end tabs pointing upward and the flange to the rear, pointing downward. Use 2 of the **1/4x1/2"** Phillips-head screws. Do not fully tighten. See **Fig. 4**.
9. Place doors into the hinge holes of the bottom shelf and door bracket. Push door bracket down until doors are secure and can open and close freely. Do not fully tighten door bracket screws. See **Fig. 4**.
10. Remove protective film from doors. Install door handles to doors using 4 of the **3/16x3/8"** Phillips-head screws. See **Fig. 4**.
11. Attach the 4 side shelf brackets to the tops of the cart legs using 8 of the **1/4x1/2"** Phillips-head screws.
IMPORTANT: Bracket with cut-out installs on front left leg. Be sure the flat side of each bracket faces outward. Fully tighten. See **Fig. 4**.
12. Place the sideburner shelf over the left brackets and cross brace. Be sure ignitor wire is hanging loose. Be sure the inside shelf holes align with cross brace holes. Secure shelf firmly to the ends of the brackets using 2 of the **1/4x1/2"** Phillips-head screws. **Repeat this procedure** for the side shelf on the right side of the cart. See **Fig. 4**.

FIGURE 4

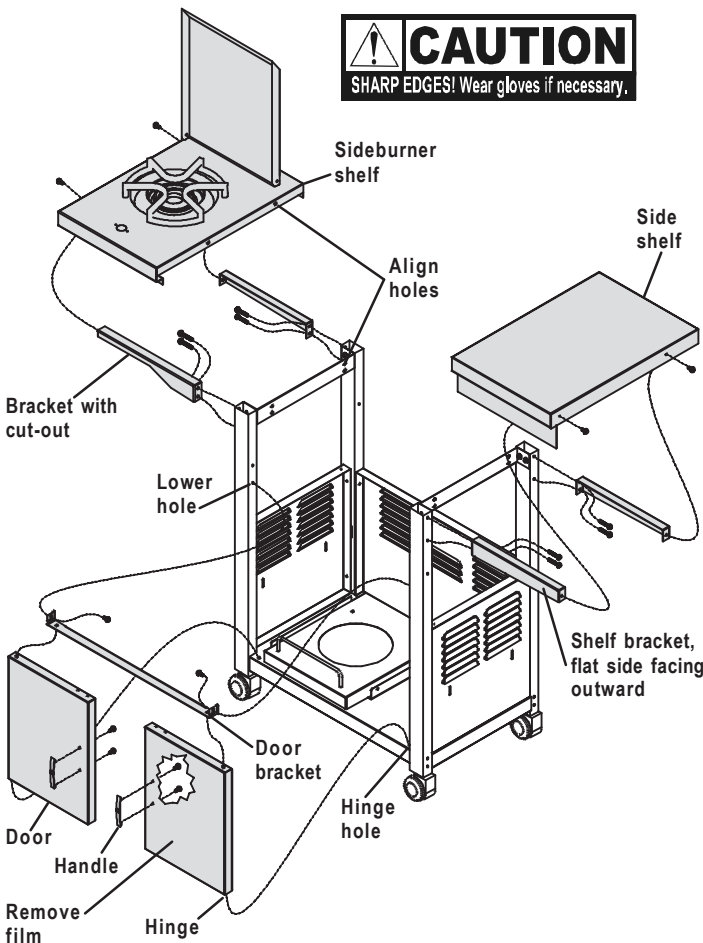
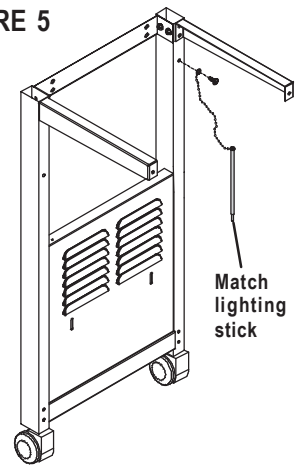

FIGURE 5

13. Attach match lighting stick and chain to the right rear leg, below shelf bracket, using one **M4x10mm**, self-tapping, Phillips-head screw. See **Fig. 5**.



To reduce the weight of the grill head, open the grill lid and remove the packed components. **This step requires 2 people to lift and position the grill head onto the cart.**

14. **HINT:** Slide grill head into cart from the front. **Use care to avoid scratching tops of side shelves.** Align the 2 holes beneath the hang ledge on each side of the grill head with the 2 holes in the side shelf and cross brace on the cart. Raise the grill lid and insert 4 of the **1/4x3/4"** Phillips-head screws. Beneath the side shelves, add **1/4"** nuts. Do not fully tighten. See **Fig. 6**.
15. Attach heat indicator to grill lid using nut provided. Make sure graphics on heat indicator are properly oriented before tightening nut. See **Fig. 6**.

FIGURE 6

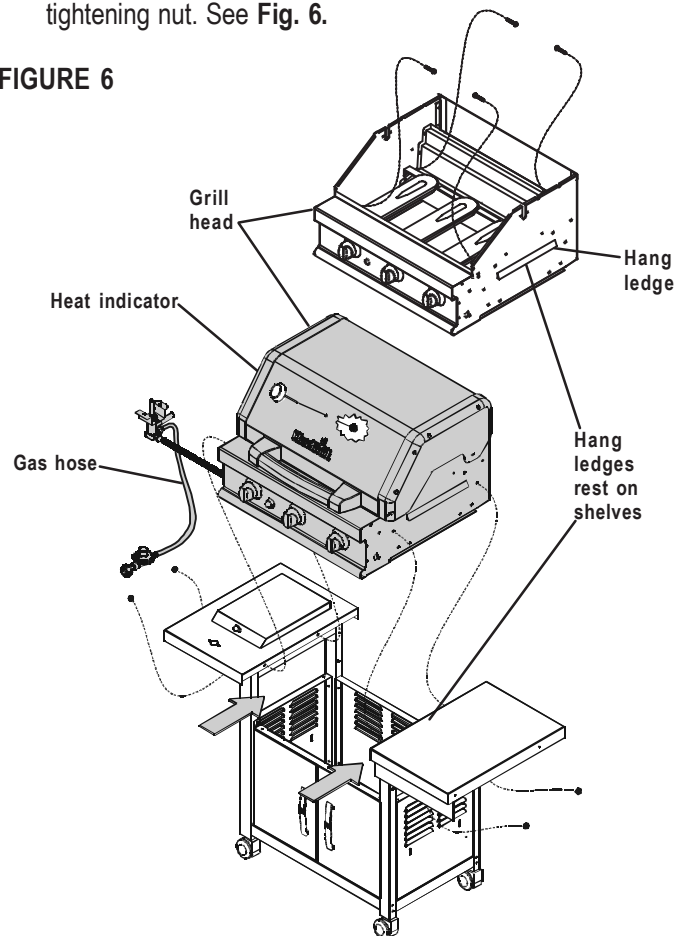

16. Firmly attach ignitor wire from sideburner to the ignitor wire from the grill head. **See Fig. 7a.** Beneath left shelf, insert sideburner valve into sideburner tube. **See Fig. 7 for proper engagement.** Attach sideburner valve to shelf using 2 of the **M4x10** Phillips-head screws and washers. Place knob seat, spring, and sideburner knob over valve stem.

FIGURE 7

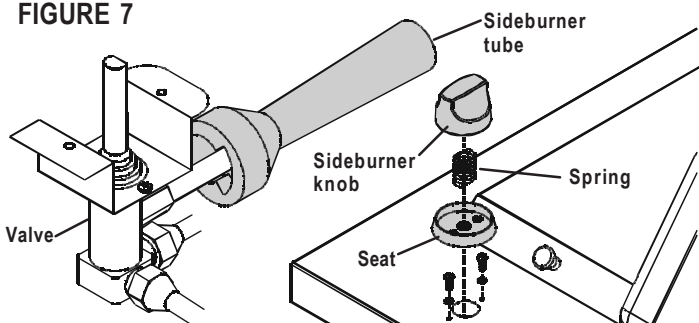
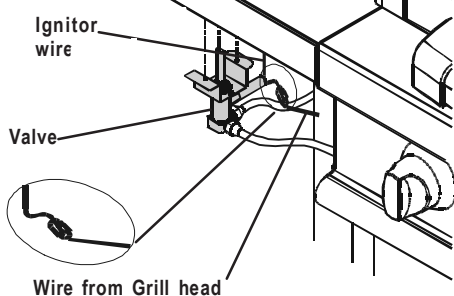

FIGURE 7a



17. Secure grill head to all cart legs using 4 of the **1/4x2-1/2"** Phillips-head screws and **1/4"** nuts. **See Fig. 8.**

18. Fully tighten all leg screws, rear panel screws, door bracket screws, and grill head screws.

19. From the back of the cart, slide the grease draining tray into the grill head. Place the grease receptacle into the notches on the bottom of the tray. **See Fig. 8.**

FIGURE 8

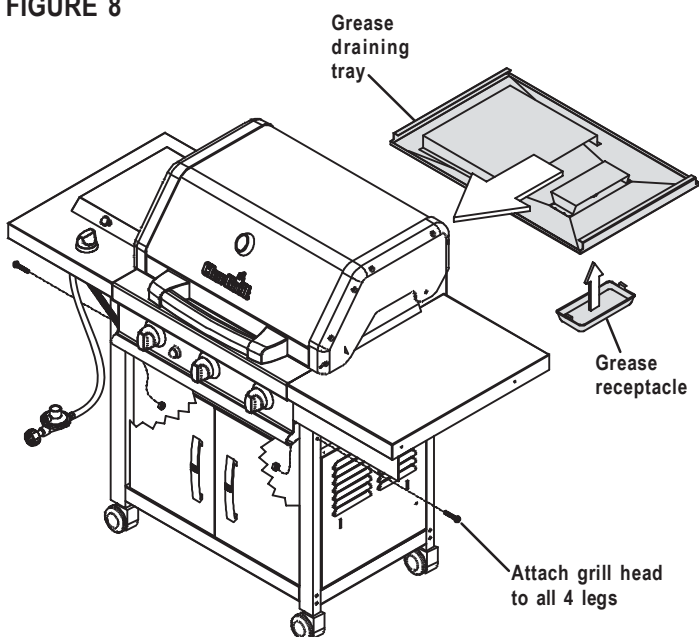

20. Place your LP gas tank (*not included*) onto the pull-out tank tray and push tray into cart. Be sure the tank valve is facing forward. **See Fig. 9. READ USE & CARE SECTION BEFORE ATTACHING REGULATOR TO LP TANK.**

FIGURE 9

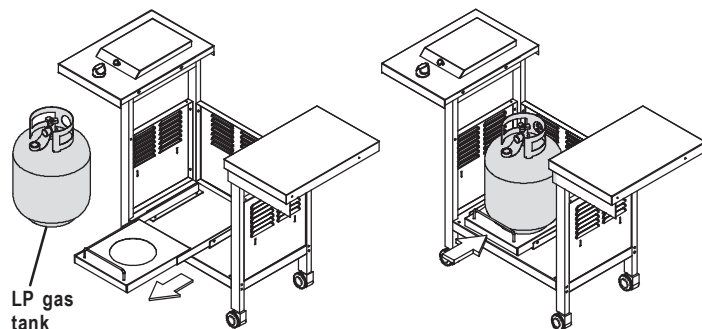

21. Unscrew the ignitor cap located on the control panel and remove the contact and spring from the ignitor slot. **See Fig. 10.**

22. Place the supplied AA battery into the ignitor slot with the positive pole facing toward you.

23. Place the spring with contact over the battery. Screw the ignitor cap back onto the control panel.

FIGURE 10

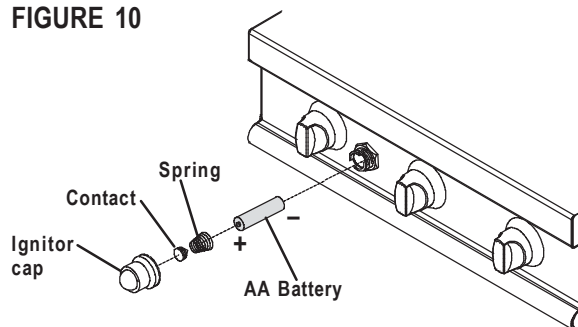

24. Attach panel to front of sideburner shelf by placing top lip of panel **ABOVE** bottom lip of shelf. Secure using three **3/16"x3/8"** Phillips-head screws and **3/16"** nuts. Fully Tighten. **See Fig. 11.**

FIGURE 11

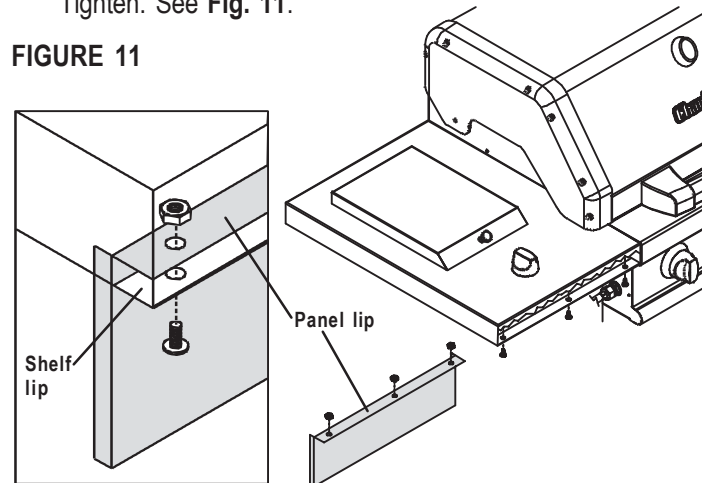

25. Place the 3 flame tamers on the lower ledge above burners. See Fig. 12. They should meet in the center.
26. Place the cooking grids or griddle on the ledge above the flame tamers.
27. Place the secondary cooking rack into the slots on the upper left and upper right of the grill bowl panels.

FIGURE 12

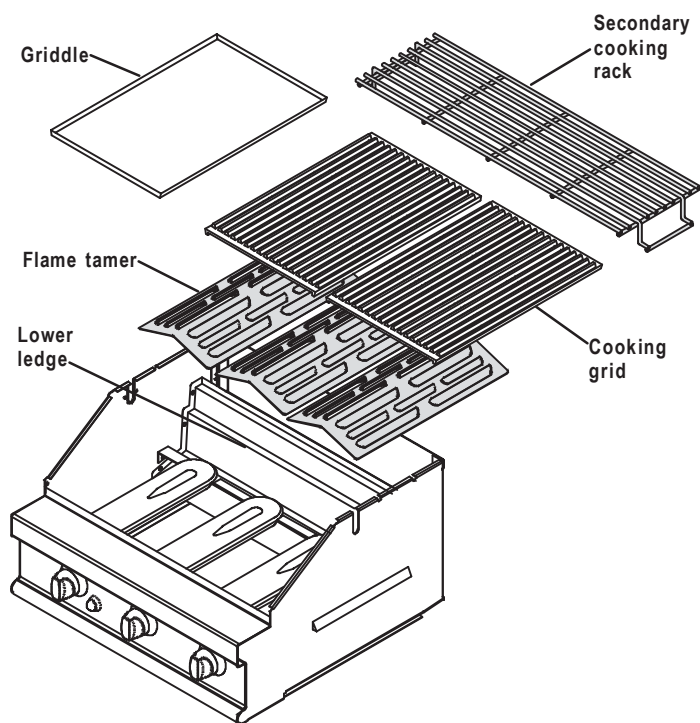

Before Your First Cookout

- Perform the leak test as indicated in the use and care section.
- Wash the cooking grids, griddle, cooking rack, and all stainless steel surfaces with warm, soapy water. Rinse and dry thoroughly.
- Light burners. Check to make sure they are lit, then close the lid and warm the grill on HI for 15 minutes. Curing of paint and parts will produce an odor only on first lighting.

Use and Care

LP Tank

- **The LP tank used with your grill must meet the following requirements:**
- Purchase LP tanks only with these required measurements: 12" (30.5cm) (diameter) x 18" (45.7 cm) (tall) with 20 lb. (9 kg.) capacity maximum.
- Be constructed and marked in accordance with specifications for LP tank of the U.S. Department of Transportation (DOT) or for Canada, CAN/CSA-B339, cylinders, spheres and tubes for transportation of dangerous goods, Transport Canada (TC). See LP tank collar for marking.
- LP tank valve must have:
 - Type 1 outlet compatible with regulator or grill.
 - Safety relief valve.
 - UL listed Overfill Protection Device (OPD). This OPD safety feature is identified by a unique triangular hand wheel. **Use only tanks equipped with this type of valve.**
- Supply system must be arranged for vapor withdrawal and include collar to protect LP tank valve.



LP (Liquefied Petroleum Gas)

- Is nontoxic, odorless and colorless when produced. **For Your Safety**, LP gas has been given an odor (similar to rotten cabbage) so that it can be smelled.
- LP gas is highly flammable and may ignite unexpectedly when mixed with air.

LP Tank Filling

- Use only licensed and experienced dealers.
- LP tank **must be purged** before filling.
- Dealer should **NEVER** fill LP tank more than 80% of LP tank volume. Volume of propane in tank will vary by temperature.
- A frosty regulator indicates gas overfill. Immediately close LP tank valve and call local LP gas dealer for assistance.
- Do not release liquid propane (LP) gas into the atmosphere. This is a hazardous practice.
- To remove gas from LP tank, contact an LP dealer or call a local fire department for assistance. Check the telephone directory under "Gas companies" for nearest certified LP dealers.
- LP tank Exchange: You may choose to replace your empty LP tank through an exchange service. Use only those reputable exchange companies that inspect, precision fill, test and certify their cylinders. **Exchange for OPD safety feature equipped tank as described in LP Tank**
- Always keep LP tank in upright position during use, transit or storage.
- **Leak test LP tank BEFORE connecting to grill.**

LP Tank Leak Test

For your safety

- Leak test must be repeated each time LP tank is exchanged or refilled.
- Do not smoke during leak test.
- Do not use an open flame to check for gas leaks.
- Grill must be leak checked outdoors in well-ventilated area, away from ignition sources such as gas fired or electrical appliances. During leak test, keep grill away from open flames or sparks.



Use a clean paint brush and 50/50 soap and water solution. **Use mild soap and water.**

▲ Do not use household cleaning agents.
Damage to gas train components can result.

Brush soapy solution onto the shaded areas.

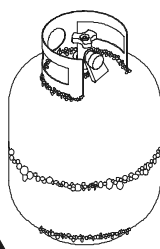
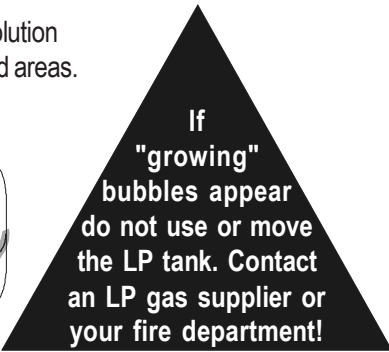
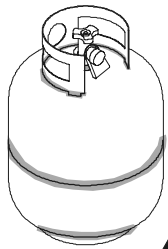

Connecting The Regulator To The LP Tank

1. LP tank must be properly secured onto grill.
2. Turn all control knobs including sideburner (if featured) to the OFF position.
3. Turn LP tank OFF by turning hand-wheel clockwise to a **full stop**.
4. Remove the protective cap from LP tank valve. Always use cap and strap supplied with valve.

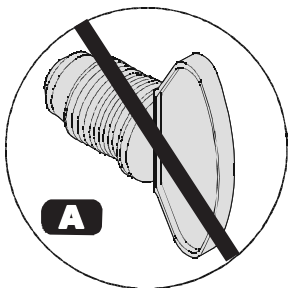
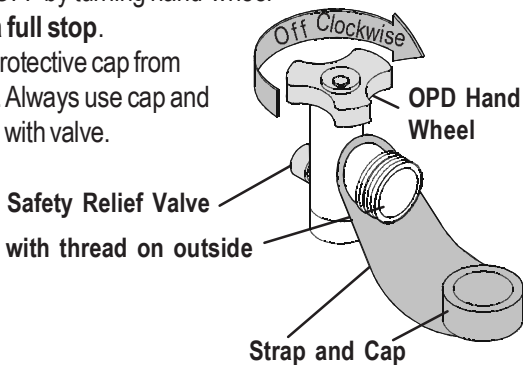

Use of this POL transport plug (A) (plastic part with external threads) will defeat safety feature of valve.

5. Hold regulator, insert nipple (B) into LP tank valve. Hand tighten coupling nut, *holding regulator in a straight line (C) with LP tank valve* so as not to cross thread the connection.

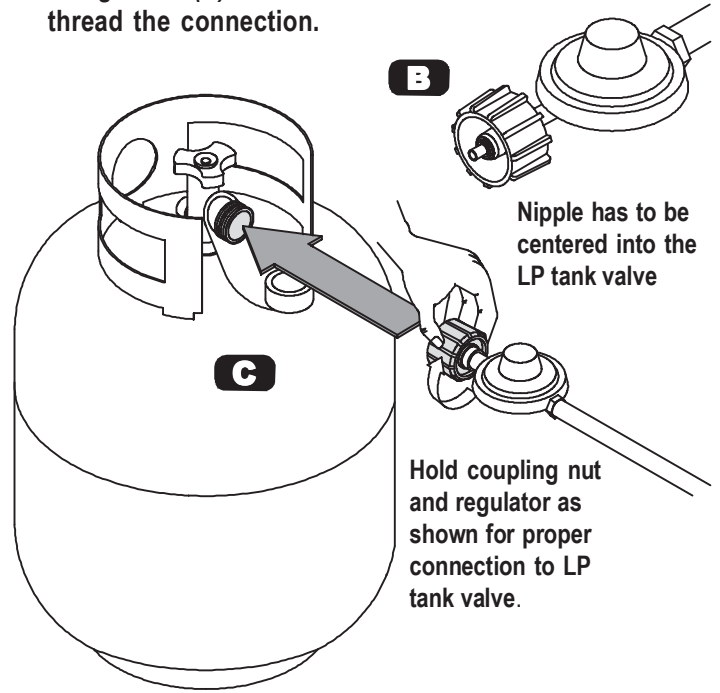

Nipple has to be centered into the LP tank valve

Hold coupling nut and regulator as shown for proper connection to LP tank valve.

6. Turn the coupling nut clockwise to tighten to a full solid stop. The regulator will seal on the back-check feature in LP tank valve, resulting in some resistance. **An additional one-half to three quarters turn is required to complete connection. Tighten by hand only - do not use tools.**

NOTE: If you cannot complete connection, disconnect regulator and repeat steps 5 and 6. If you are still unable to complete the connection, **do not use this regulator!**

▲ WARNING

- Do not insert any foreign objects into the valve outlet. You may damage the valve and cause a leak. Leaking propane may result in explosion, fire, severe personal injury, or death.
- Never attempt to attach this grill to the self-contained LP gas system of a camper trailer or motor home.
- Do not use grill until leak checked.
- If leak is detected at any time, **STOP** and call the Fire Department.
- If you cannot stop a gas leak, *immediately* close LP tank valve and call LP gas supplier or your fire department!

⚠ DANGER

- NEVER store a spare LP tank under or near grill or in enclosed areas.
- Never fill the cylinder beyond 80% full. An overfilled spare LP tank is hazardous due to possible gas released from the safety relief valve. The safety relief valve on a LP tank could activate releasing gas and cause a fire.
- If you see, smell or hear escaping gas, immediately get away from the LP tank/grill and call your fire department.
- All spare LP tanks must have safety caps installed on the LP tank outlet.

LP Tank Removal, Transport And Storage

- Turn OFF all control knobs and LP tank valve. Turn coupling nut counter clockwise by hand only - do not use tools to disconnect. Lift LP tank wire upward off of LP tank collar, lift LP tank up and off of support bracket. Install safety cap onto LP tank valve. Always use cap and strap supplied with valve. **Failure to use safety cap as directed may result in serious personal injury and/or property damage.**

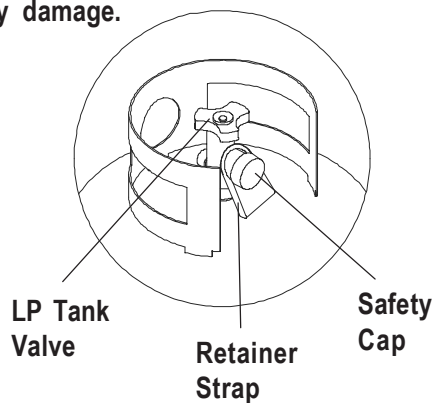

- A disconnected LP tank in storage or being transported must have a safety cap installed (as shown). Do not store an LP tank in enclosed spaces such as a carport, garage, porch, covered patio or other building. Never leave a LP tank inside a vehicle which may become overheated by the sun.
- Do not store LP tank in an area where children play.

Leak Testing Valves, Hoses and Regulator

1. Turn all grill control knobs to OFF.
2. Be sure regulator is tightly connected to LP tank.
3. Completely open LP tank valve by turning hand wheel counter clockwise. If you hear a *rushing sound*, turn gas off immediately. There is a major leak at the connection. **Correct before proceeding.**

4. Brush soapy solution onto following connections:

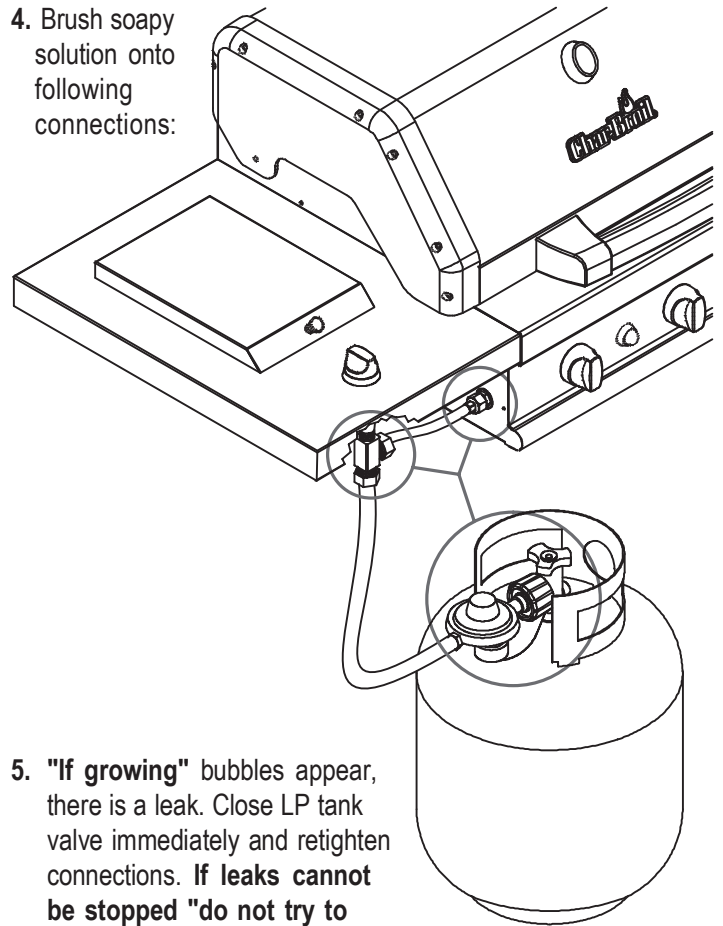

5. "If growing" bubbles appear, there is a leak. Close LP tank valve immediately and retighten connections. **If leaks cannot be stopped "do not try to repair."** Call for replacement parts.

Order new parts by giving the serial, model number and name of items needed to the Grill Service Center at ☎1-800-241-7548 U.S. or 1-800-387-6057 CAN.

6. Always close LP tank valve after performing leak test by turning hand wheel clockwise.

Safety Tips

- ▲ Before opening LP tank valve, check the coupling nut for tightness.
- ▲ When grill is not in use, turn off all control knobs and LP tank valve.
- ▲ Never move grill while in operation or still hot.
- ▲ When moving the grill push it forward, do not pull from behind.
- ▲ Use long-handled barbecue utensils to avoid burns and splatters.
- ▲ Do not remove grease receptacle or tray until grill has completely cooled.
- ▲ If you notice grease or other hot material dripping from grill onto valve, hose or regulator turn off gas supply at once. Determine the cause, correct, clean and inspect valve, hose and regulator before continuing. Perform a leak test.
- ▲ The regulator may make a humming or whistling noise during operation. This will not affect safety or use of grill.
- ▲ If you have a grill problem see the "Troubleshooting Section".

WARNING

For Safe Use Of Your Grill:

- Do not let children operate or play near grill.
- Keep grill area clear and free from materials that burn.
- Do not block holes in bottom or back of grill.
- Check burner flames regularly.
- Use grill only in well-ventilated space. NEVER use in enclosed space such as carport, garage, porch, covered patio, or under a surface that can catch fire.
- Use grill at least 3 ft. from any wall or surface. Maintain 10 ft. clearance to objects that can catch fire or sources of ignition such as pilot lights on water heaters, live electrical appliances, etc.
- Do not use charcoal, briquets or lava rock in this grill.
- **Apartment Dwellers:**
Check with management to learn the requirements and fire codes for using an LP Gas Grill in an apartment. If allowed use outside on the ground floor with a three (3) foot clearance from walls or rails. Do not use on or under balconies made of wood.
- **NEVER attempt to light burner with lid closed. A buildup of non-ignited gas inside a closed grill is hazardous.**
- **Never operate grill with LP tank out of correct position.**
- **Always close LP tank valve and remove coupling nut before moving LP tank from specified operating position.**

CAUTION

- Putting out grease fires by closing the lid is not possible. Grills are well ventilated for safety reasons.
- Do not use water on a grease fire. Personal injury may result. If a grease fire develops turn knobs and LP tank off.
- Do not leave grill unattended while preheating or burning off on high. If grill has not been regularly cleaned a grease fire can occur that may damage the product.

Ignitor Lighting

Do not lean over grill while lighting.

1. Open lid during lighting
2. To ignite any burner, turn knob to HI, push and hold ELECTRONIC IGNITOR button for 5 seconds.
3. If ignition does not take place within 5 seconds, turn all burner knobs to OFF, wait 5 minutes, then repeat lighting procedure.
4. If IGNITOR does not work, follow match lighting instructions.

Match Lighting

Do not lean over grill while lighting.

1. Open lid during lighting.
2. Place lit match into match lighting stick, then into lighting hole on right side of grill.
3. Push in and turn far right burner knob to HI. Be sure burner lights and stays lit.
4. Light adjacent burners in sequence by pushing knobs in and turning to HI.

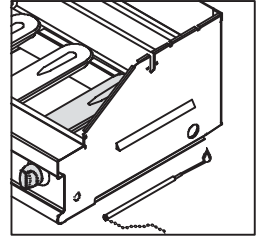

WARNING

- If burner does not light turn knobs to OFF, wait 5 minutes, try again.

Match Lighting

1. To match light SIDEBURNER, open sideburner cover.
2. Place lit match near burner.
3. Push in and turn sideburner knob counter-clockwise. Be sure burner lights and stays lit.

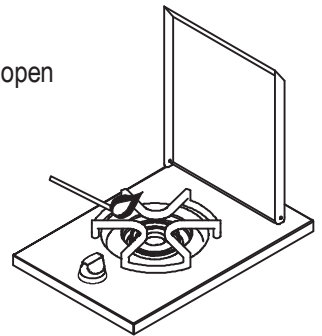

Burner Flame Check

- Remove grates and flametamers. Light burners, rotate knobs from HI to LOW. You should see a smaller flame in LOW position than seen on HI. Always check flame prior to each use. Perform flame check for sideburner. If only low flame is seen refer to "Sudden drop or low flame" in the *Troubleshooting Section*.



Turning Grill Off

- Turn all knobs to OFF position. Turn LP tank OFF by turning hand-wheel clockwise to a full stop.

Ignitor Check

- **Turn gas off at LP tank.** Push and hold electronic ignitor button. "Clicks" should be heard and spark seen each time between collector box or burner and electrode. See "Troubleshooting" if no click or spark.

Valve Check

- **Important: Make sure gas is OFF at LP tank before checking valves.** Knobs lock in OFF position. To check valves, first push in knobs and release, knobs should spring back. If knobs don't spring back, replace valve assembly before using grill. Turn knobs to **LOW** position then turn back to **OFF** position. Valves should turn smoothly.

Hose Check

- Before each use, check to see if hoses are cut or worn. Replace damaged hoses before using grill. Use only valve/hose/regulator specified by manufacturer.

Cleaning The Burner Assembly

Follow these instructions to clean and/or replace parts of burner assembly or if you have trouble igniting grill.

1. **Turn gas off at control knobs and LP tank.**
2. Remove cooking grates, flamelamers, grease tray and grease receptacle.
3. Remove cotter pins from beneath each burner "foot" using a screwdriver or needle nose pliers.
4. Carefully lift each burner up and away from valve openings.

We suggest three ways to clean the burner tubes. Use the one easiest for you.

- (A) Bend a stiff wire (a light weight coat hanger works well) into a small hook. Run the hook through each burner tube and burner several times.

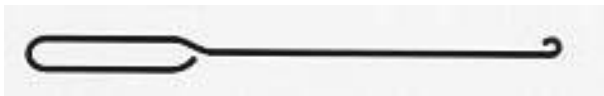

- (B) Use a narrow bottle brush with a flexible handle (do not use a brass wire brush), run the brush through each burner tube and burner several times.

- (C) **Wear eye protection:** Use an air hose to force air into the burner tube and out the burner ports. Check each port to make sure air comes out each hole.

5. Wire brush entire outer surface of burner to remove food residue and dirt.
6. Clean any blocked ports with a stiff wire such as an open paper clip.
7. Check burner for damage, due to normal wear and corrosion some holes may become enlarged. If any large cracks or holes are found replace burner.

VERY IMPORTANT: Burner tubes must reengage valve openings.

8. Carefully replace burners.
9. Replace cotter pin beneath each burner.
10. Replace grease tray and receptacle, flamelamers, and cooking grates.

General Grill Cleaning

- Do not mistake brown or black accumulation of grease and smoke for paint. Interiors of gas grills are not painted at the factory (**and should never be painted**). Apply a strong solution of detergent and water or use a grill cleaner with scrub brush to insides of grill lid and bottom. Rinse and allow to completely air dry. **Do not apply a caustic grill/oven cleaner to painted surfaces.**
- **Plastic parts:** wash with warm soapy water and wipe dry. ▲ Do not use citrisol, abrasive cleaners, degreasers or a concentrated grill cleaner on plastic parts. Damage to and failure of parts can result.

▲ CAUTION



Clean burners prior to use after storing, at the beginning of grilling season or a period of one month not being used. Spiders and insects like to build nests in burner tubes (especially during colder months). These nests can cause fires in burner tubes or under grill.

- **Porcelain surfaces:** because of glass-like composition, most residue can be wiped away with baking soda/water solution or specially formulated cleaner. Use nonabrasive scouring powder for stubborn stains.
- **Painted surfaces:** Wash with mild detergent or nonabrasive cleaner and warm soapy water, wipe dry with a soft nonabrasive cloth.
- **Stainless steel surfaces:** To maintain your grill's high-quality appearance, wash with mild detergent and warm soapy water, wipe dry with a soft cloth after each use. Baked-on grease deposits may require the use of an abrasive plastic cleaning pad.

Storing Your Grill

- Clean cooking grates
- Store in dry location.
- When LP tank is connected to grill, store outdoors in well-ventilated space and out of reach of children.
- Cover grill if stored outdoors. Choose from a variety of grill covers offered by Char-Broil.
- Store grill indoors **ONLY** if LP tank is turned off and disconnected, removed from grill and stored outdoors.
- When removing grill from storage follow "Cleaning the Burner Assembly" instructions before starting grill.

Indirect Cooking

Poultry and large cuts of meat cook slowly to perfection on the grill by indirect heat. The heat from selected burners circulates gently throughout the grill, cooking meat or poultry without the touch of a direct flame. This method greatly reduces flare-ups when cooking extra fatty cuts because there is no direct flame to ignite the fats and juices that drip during cooking.

Indirect Cooking Instructions

- Always cook with the lid closed.
- Due to weather conditions, cooking times may vary. During cold and windy conditions the temperature setting may need to be increased to insure sufficient cooking temperatures.

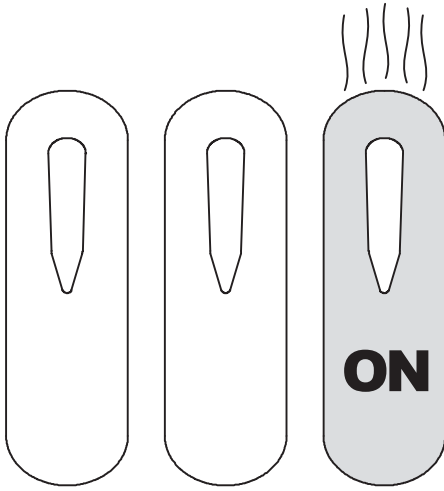

1 Burner Cooking

Cook with direct or indirect heat.
Best for smaller meals or foods.
Consumes less fuel.

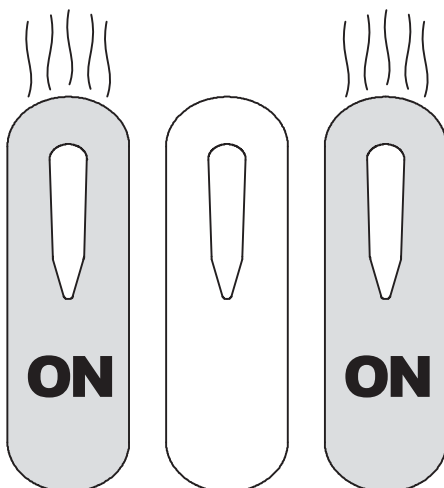

2 Burner Cooking

Great indirect cooking on low.
Produces slow, even heating.
Ideal for slow roasting and baking.

Food Safety

- Food safety is a very important part of enjoying the outdoor cooking experience. To keep food safe from harmful bacteria, follow these four basic steps:

Clean: Wash hands, utensils, and surfaces with hot soapy water before and after handling raw meat and poultry.

Separate: Separate raw meats and poultry from ready-to-eat foods to avoid cross contamination. Use a clean platter and utensils when removing cooked foods.

Cook: Cook meat and poultry thoroughly to kill bacteria. Use a thermometer to ensure proper internal food temperatures.

Chill: Refrigerate prepared foods and leftovers promptly.

How To Tell If Meat Is Grilled Thoroughly

- Meat and poultry cooked on a grill often browns very fast on the outside. Use a meat thermometer to be sure food has reached a safe internal temperature, and cut into food to check for visual signs of doneness.
- Whole poultry should reach 180° F; breasts, 170° F. Juices should run clear and flesh should not be pink.
- Hamburgers made of any ground meat or poultry should reach 160° F, and be brown in the middle with no pink juices. Beef, veal and lamb steaks, roasts and chops can be cooked to 145° F. All cuts of pork should reach 160° F.
- NEVER partially grill meat or poultry and finish cooking later. Cook food completely to destroy harmful bacteria.
- When reheating takeout foods or fully cooked meats like hot dogs, grill to 165° F, or until steaming hot.

Troubleshooting

Problem	Possible Cause	Prevention/Cure
Burner will not light using ignitor.	<p>Wires and/or electrode covered with cooking residue.</p> <p>Electrode cracked or broken "sparks at crack"</p> <p>Electrode tip not in proper position</p> <p>Wires are loose or disconnected.</p> <p>Wire is shorting (sparking) between ignitor and electrode.</p> <p>Dead battery.</p>	<p>Clean wires and/or electrode with rubbing alcohol and clean swab.</p> <p>Replace electrode(s).</p> <p>Main Burners: Tip of electrode should be pointing toward tip of collector box. The distance should be 1/8" to 1/4", adjust if necessary.</p> <p>Sideburner: Tip of electrode should be pointing toward gas port opening on burner. The distance should be 1/8" to 3/16", adjust if necessary.</p> <p>Reconnect wires or replace electrode/wire assembly.</p> <p>Replace ignitor wire/electrode assembly.</p> <p>Replace with a new AA battery.</p>
Burners will not match light.	<p>No gas flow.</p> <p>Obstruction of gas flow.</p> <p>Disengagement of burner to valve.</p>	<p>Turn gas on at source.</p> <p>Clear burner tubes.</p> <p>Reengage burner and valve.</p>
Flames blow out.	<p>High or gusting winds.</p>	<p>Turn front of grill to face wind or increase flame height.</p>
Flare-up.	<p>Grease buildup.</p> <p>Excessive fat in meat.</p> <p>Excessive cooking temperature.</p>	<p>Clean grill.</p> <p>Trim fat from meat before grilling.</p> <p>Adjust (lower) temperature accordingly or use indirect cooking.</p>
Persistent grease fire.	<p>Grease trapped by food buildup around burner system.</p>	<p>Turn knobs to OFF. Turn gas off at gas source. Leave lid in position and let fire burn out. <i>After grill cools, remove and clean all parts.</i></p>
Flashback... (fire in burner tubes)	<p>Burner and/or burner tubes are blocked.</p>	<p>Clean burner and/or burner tubes.</p>



A Division of W.C. Bradley Co.

P. O. Box 1240

Columbus, GA 31902-1240